

## Enstrom TH-28/480 Series Maintenance Manual

### Revision 29 Change Pages

Revision 29, dated 08 Dec 2025, applies to the Enstrom TH-28/480 Series Maintenance Manual, 2001 Edition. Place this cover sheet behind the “Record of Revisions” card after removing and inserting the pages listed below.

**NOTE:** This Change Pages Letter reissue replaces the Changes Pages Letter dated February 12, 2026, which had a typographical error.

Remove Pages	Insert Pages
vii through viii	vii through viii
xiii through xvi	xiii through xvi
MM-2-13 through MM-2-14	MM-2-13 through MM-2-14
MM-2-17 through MM-2-18	MM-2-17 through MM-2-18
MM-3-1 through MM-3-4	MM-3-1 through MM-3-4
MM-4-27 through MM-4-28	MM-4-27 through MM-4-28
MM-4-91 through MM-4-92	MM-4-91 through MM-4-92
MM-9-15 through MM-9-18	MM-9-15 through MM-9-18
MM-9-23 through MM-9-24	MM-9-23 through MM-9-24
MM-9-69 through MM-9-70	MM-9-69 through MM-9-70
MM-10-9 through MM-10-12	MM-10-9 through MM-10-12
MM-10-15 through MM-10-22	MM-10-15 through MM-10-22
MM-10-25 through MM-10-28	MM-10-25 through MM-10-28
MM-10-37 through MM-10-42	MM-10-37 through MM-10-42
MM-10-61 through MM-10-64	MM-10-61 through MM-10-64
MM-11-41 through MM-11-42	MM-11-41 through MM-11-42

..... End of List .....



INTENTIONALLY LEFT BLANK

# ENSTROM TH-28/480 SERIES MAINTENANCE MANUAL

## EFFECTIVE PAGE LIST

Page	Date	Page	Date
i	No Date	MM-2-21	Feb 28/2020
ii	20 May 2025	MM-2-22	27 Jan 2025
iii	27 Jan 2025	MM-2-23	27 Jan 2025
iv	Apr 25/13	MM-2-24	27 Jan 2025
v	27 Jan 2025	MM-3-1	27 Jan 2025
vi	27 Jan 2025	MM-3-2	08 Dec 2025
vii	08 Dec 2025	MM-3-3	08 Dec 2025
viii	08 Dec 2025	MM-3-4	Dec 4/15
ix	20 May 2025	MM-3-5	27 Jan 2025
x	27 Jan 2025	MM-3-6	Dec 4/15
xi	20 May 2025	MM-3-7	Dec 4/15
xii	20 May 2025	MM-3-8	Aug 22/16
xiii	08 Dec 2025	MM-3-9	27 Jan 2025
xiv	08 Dec 2025	MM-3-10	Dec 4/15
xv	08 Dec 2025	MM-4-1	27 Jan 2025
xvi	20 May 2025	MM-4-2	20 May 2025
xvii	20 May 2025	MM-4-3	27 Jan 2025
xviii	20 May 2025	MM-4-4	Jun 24/11
xix	20 May 2025	MM-4-5	27 Jan 2025
xx	20 May 2025	MM-4-6	27 Jan 2025
MM-1-1	27 Jan 2025	MM-4-7	20 May 2025
MM-1-2	Feb 9/01	MM-4-8	27 Jan 2025
MM-1-3	27 Jan 2025	MM-4-9	20 May 2025
MM-1-4	Feb 28/2020	MM-4-10	27 Jan 2025
MM-1-5	27 Jan 2025	MM-4-11	27 Jan 2025
MM-1-6	20 May 2025	MM-4-12	27 Jan 2025
MM-1-7	27 Jan 2025	MM-4-12.1	27 Jan 2025
MM-1-8	27 Jan 2025	MM-4-12.2	Oct 20/09
MM-2-1	27 Jan 2025	MM-4-13	27 Jan 2025
MM-2-2	Oct 20/09	MM-4-14	Oct 20/09
MM-2-3	Apr 25/13	MM-4-15	Feb 20/08
MM-2-4	Apr 25/13	MM-4-16	Apr 25/13
MM-2-5	Feb 28/2020	MM-4-17	Oct 20/09
MM-2-6	Apr 25/13	MM-4-18	Jun 24/11
MM-2-7	Apr 25/13	MM-4-19	Jul 3/15
MM-2-8	Feb 9/01	MM-4-20	Jul 3/15
MM-2-9	27 Jan 2025	MM-4-21	Feb 28/2020
MM-2-10	Feb 9/01	MM-4-22	Feb 28/2020
MM-2-11	27 Jan 2025	MM-4-22.1	27 Jan 2025
MM-2-12	20 May 2025	MM-4-22.2	27 Jan 2025
MM-2-13	08 Dec 2025	MM-4-23	27 Jan 2025
MM-2-14	20 May 2025	MM-4-24	27 Jan 2025
MM-2-15	20 May 2025	MM-4-25	27 Jan 2025
MM-2-16	20 May 2025	MM-4-26	27 Jan 2025
MM-2-17	08 Dec 2025	MM-4-27	27 Jan 2025
MM-2-18	Feb 28/2020	MM-4-28	08 Dec 2025
MM-2-19	Feb 28/2020	MM-4-29	27 Jan 2025
MM-2-20	Feb 28/2020	MM-4-30	27 Jan 2025

# ENSTROM TH-28/480 SERIES MAINTENANCE MANUAL

## EFFECTIVE PAGE LIST

Page	Date	Page	Date
MM-4-31	27 Jan 2025	MM-4-80	Feb 20/08
MM-4-32	27 Jan 2025	MM-4-81	20 May 2025
MM-4-33	Apr 25/13	MM-4-82	Feb 20/08
MM-4-34	Feb 28/2020	MM-4-83	Apr 25/13
MM-4-35	Apr 25/13	MM-4-84	Feb 20/08
MM-4-36	Feb 20/08	MM-4-85	Jun 24/11
MM-4-37	27 Jan 2025	MM-4-86	Feb 20/08
MM-4-38	Feb 28/2020	MM-4-87	Feb 20/08
MM-4-39	Nov 15/10	MM-4-88	Feb 20/08
MM-4-40	20 May 2025	MM-4-89	Feb 20/08
MM-4-41	27 Jan 2025	MM-4-90	27 Jan 2025
MM-4-42	27 Jan 2025	MM-4-91	08 Dec 2025
MM-4-43	20 May 2025	MM-4-92	20 May 2025
MM-4-44	20 May 2025	MM-4-93	Apr 25/13
MM-4-45	27 Jan 2025	MM-4-94	27 Jan 2025
MM-4-46	20 May 2025	MM-4-95	Feb 28/2020
MM-4-47	27 Jan 2025	MM-4-96	27 Jan 2025
MM-4-48	20 May 2025	MM-4-97	27 Jan 2025
MM-4-49	27 Jan 2025	MM-4-98	27 Jan 2025
MM-4-50	27 Jan 2025	MM-5-1	27 Jan 2025
MM-4-51	20 May 2025	MM-5-2	Feb 9/01
MM-4-52	27 Jan 2025	MM-5-3	Apr 25/13
MM-4-53	27 Jan 2025	MM-5-4	Feb 28/2020
MM-4-54	27 Jan 2025	MM-5-5	Feb 9/01
MM-4-55	Jun 24/11	MM-5-6	Feb 9/01
MM-4-56	Jun 24/11	MM-5-7	Feb 9/01
MM-4-57	20 May 2025	MM-5-8	20 May 2025
MM-4-58	Jun 24/11	MM-5-9	27 Jan 2025
MM-4-59	27 Jan 2025	MM-5-10	Dec 21/09
MM-4-60	Jun 24/11	MM-5-11	27 Jan 2025
MM-4-61	20 May 2025	MM-5-12	27 Jan 2025
MM-4-62	20 May 2025	MM-5-13	Apr 25/13
MM-4-63	Feb 28/2020	MM-5-14	Apr 25/13
MM-4-64	Feb 28/2020	MM-5-15	Apr 25/13
MM-4-65	Feb 28/2020	MM-5-16	Apr 25/13
MM-4-66	Feb 28/2020	MM-6-1	27 Jan 2025
MM-4-67	Feb 28/2020	MM-6-2	27 Jan 2025
MM-4-68	Feb 28/2020	MM-6-3	27 Jan 2025
MM-4-69	Feb 28/2020	MM-6-4	27 Jan 2025
MM-4-70	Feb 28/2020	MM-6-5	27 Jan 2025
MM-4-71	Feb 28/2020	MM-6-6	20 May 2025
MM-4-72	Feb 28/2020	MM-6-6.1	27 Jan 2025
MM-4-73	Feb 20/08	MM-6-6.2	Nov 15/10
MM-4-74	Jun 24/11	MM-6-7	Nov 15/10
MM-4-75	27 Jan 2025	MM-6-8	Nov 15/10
MM-4-76	27 Jan 2025	MM-6-9	Nov 15/10
MM-4-77	27 Jan 2025	MM-6-10	Nov 15/10
MM-4-78	27 Jan 2025		
MM-4-79	27 Jan 2025		

# ENSTROM TH-28/480 SERIES MAINTENANCE MANUAL

## EFFECTIVE PAGE LIST

Page	Date	Page	Date
MM-8-91	27 Jan 2025	MM-9-43	27 Jan 2025
MM-8-92	27 Jan 2025	MM-9-44	27 Jan 2025
MM-9-1	27 Jan 2025	MM-9-45	27 Jan 2025
MM-9-2	27 Jan 2025	MM-9-46	27 Jan 2025
MM-9-3	Apr 25/13	MM-9-47	Feb 28/2020
MM-9-4	Apr 25/13	MM-9-48	Feb 28/2020
MM-9-5	Apr 25/13	MM-9-49	20 May 2025
MM-9-6	Apr 25/13	MM-9-50	Feb 28/2020
MM-9-7	Apr 25/13	MM-9-51	Feb 28/2020
MM-9-8	Apr 25/13	MM-9-52	Feb 28/2020
MM-9-9	Apr 25/13	MM-9-53	27 Jan 2025
MM-9-10	27 Jan 2025	MM-9-54	27 Jan 2025
MM-9-11	Apr 25/13	MM-9-55	Apr 25/13
MM-9-12	Apr 25/13	MM-9-56	Apr 25/13
MM-9-12.1	Apr 25/13	MM-9-57	Feb 9/01
MM-9-12.2	Apr 25/13	MM-9-58	Feb 9/01
MM-9-12.3	Apr 25/13	MM-9-59	Feb 9/01
MM-9-12.4	Apr 25/13	MM-9-60	Feb 9/01
MM-9-13	Apr 25/13	MM-9-61	Oct 13/04
MM-9-14	Apr 25/13	MM-9-62	Feb 28/2020
MM-9-15	Aug 22/16	MM-9-63	Feb 28/2020
MM-9-16	08 Dec 2025	MM-9-64	Feb 28/2020
MM-9-17	Feb 9/01	MM-9-65	Feb 28/2020
MM-9-18	08 Dec 2025	MM-9-66	Feb 28/2020
MM-9-19	Feb 28/2020	MM-9-67	Feb 28/2020
MM-9-20	Feb 28/2020	MM-9-68	Feb 28/2020
MM-9-21	Feb 28/2020	MM-9-69	08 Dec 2025
MM-9-22	Feb 28/2020	MM-9-70	Feb 28/2020
MM-9-23	08 Dec 2025	MM-9-71	Feb 28/2020
MM-9-24	08 Dec 2025	MM-9-72	Feb 28/2020
MM-9-25	Apr 25/13	MM-9-73	Feb 28/2020
MM-9-26	Apr 25/13	MM-9-73.1	Feb 28/2020
MM-9-27	27 Jan 2025	MM-9-73.2	Feb 28/2020
MM-9-28	20 May 2025	MM-9-73.3	Feb 28/2020
MM-9-29	27 Jan 2025	MM-9-73.4	Feb 28/2020
MM-9-30	Apr 25/13	MM-9-74	Feb 28/2020
MM-9-31	Feb 28/2020	MM-9-75	Feb 9/01
MM-9-32	Feb 9/01	MM-9-76	Feb 9/01
MM-9-33	Aug 22/16	MM-9-77	27 Jan 2025
MM-9-34	Jul 3/15	MM-9-78	Feb 9/01
MM-9-35	Jun 24/11	MM-9-79	Apr 25/13
MM-9-36	27 Jan 2025	MM-9-80	Feb 9/01
MM-9-37	Feb 28/2020	MM-9-81	Feb 9/01
MM-9-38	Feb 28/2020	MM-9-82	Feb 9/01
MM-9-39	Jun 24/11	MM-9-83	Feb 9/01
MM-9-40	Feb 28/2020	MM-9-84	Feb 9/01
MM-9-41	Feb 28/2020		
MM-9-42	Aug 22/16		

# ENSTROM TH-28/480 SERIES MAINTENANCE MANUAL

## EFFECTIVE PAGE LIST

Page	Date	Page	Date
MM-9-85	Feb 9/01	MM-9-120	Feb 9/01
MM-9-86	Feb 9/01	MM-9-121	27 Jan 2025
MM-9-86.1	Jun 25/14	MM-9-122	27 Jan 2025
MM-9-86.2	Jun 25/14	MM-9-123	27 Jan 2025
MM-9-87	Aug 22/16	MM-9-124	27 Jan 2025
MM-9-88	27 Jan 2025	MM-9-125	Feb 9/01
MM-9-89	27 Jan 2025	MM-9-126	27 Jan 2025
MM-9-90	27 Jan 2025	MM-9-127	27 Jan 2025
MM-9-91	27 Jan 2025	MM-9-128	Apr 25/13
MM-9-92	27 Jan 2025	MM-10-1	20 May 2025
MM-9-93	27 Jan 2025	MM-10-2	20 May 2025
MM-9-93.1	27 Jan 2025	MM-10-3	20 May 2025
MM-9-93.2	27 Jan 2025	MM-10-4	20 May 2025
MM-9-93.3	Apr 25/13	MM-10-5	20 May 2025
MM-9-93.4	Apr 25/13	MM-10-6	20 May 2025
MM-9-94	Apr 25/13	MM-10-7	20 May 2025
MM-9-95	27 Jan 2025	MM-10-8	20 May 2025
MM-9-96	27 Jan 2025	MM-10-8.1	20 May 2025
MM-9-97	27 Jan 2025	MM-10-8.2	20 May 2025
MM-9-98	Apr 25/13	MM-10-9	08 Dec 2025
MM-9-99	Jun 25/14	MM-10-10	08 Dec 2025
MM-9-100	Apr 25/13	MM-10-11	08 Dec 2025
MM-9-101	Feb 9/01	MM-10-12	08 Dec 2025
MM-9-102	Feb 9/01	MM-10-13	20 May 2025
MM-9-103	Jun 25/14	MM-10-14	20 May 2025
MM-9-104	Apr 25/13	MM-10-15	20 May 2025
MM-9-105	Apr 25/13	MM-10-16	08 Dec 2025
MM-9-106	Jun 25/14	MM-10-17	20 May 2025
MM-9-106.1	Apr 25/13	MM-10-18	08 Dec 2025
MM-9-106.2	Jun 25/14	MM-10-19	20 May 2025
MM-9-106.3	Jun 25/14	MM-10-20	08 Dec 2025
MM-9-106.4	Jun 25/14	MM-10-21	08 Dec 2025
MM-9-106.5	Jun 25/14	MM-10-22	08 Dec 2025
MM-9-106.6	Apr 25/13	MM-10-23	20 May 2025
MM-9-107	Apr 25/13	MM-10-24	20 May 2025
MM-9-108	Feb 9/01	MM-10-25	08 Dec 2025
MM-9-109	Feb 9/01	MM-10-26	08 Dec 2025
MM-9-110	Feb 9/01	MM-10-27	20 May 2025
MM-9-111	Feb 9/01	MM-10-28	08 Dec 2025
MM-9-112	Feb 9/01	MM-10-29	20 May 2025
MM-9-113	Feb 28/2020	MM-10-30	20 May 2025
MM-9-114	Feb 28/2020	MM-10-31	20 May 2025
MM-9-115	Apr 25/13	MM-10-32	20 May 2025
MM-9-116	Feb 9/01	MM-10-33	20 May 2025
MM-9-117	Feb 9/01	MM-10-34	20 May 2025
MM-9-118	Feb 9/01		
MM-9-119	Jul 3/15		

# ENSTROM TH-28/480 SERIES MAINTENANCE MANUAL

## EFFECTIVE PAGE LIST

Page	Date	Page	Date
MM-10-35	20 May 2025	MM-11-13.1	Apr 25/13
MM-10-36	20 May 2025	MM-11-13.2	Apr 25/13
MM-10-37	20 May 2025	MM-11-14	Feb 28/2020
MM-10-38	08 Dec 2025	MM-11-15	Jun 24/11
MM-10-39	08 Dec 2025	MM-11-16	Apr 25/13
MM-10-40	08 Dec 2025	MM-11-17	Feb 28/2020
MM-10-41	08 Dec 2025	MM-11-18	27 Jan 2025
MM-10-42	20 May 2025	MM-11-19	27 Jan 2025
MM-10-43	20 May 2025	MM-11-20	27 Jan 2025
MM-10-44	20 May 2025	MM-11-21	27 Jan 2025
MM-10-45	20 May 2025	MM-11-22	27 Jan 2025
MM-10-46	20 May 2025	MM-11-23	27 Jan 2025
MM-10-47	20 May 2025	MM-11-24	27 Jan 2025
MM-10-48	20 May 2025	MM-11-25	27 Jan 2025
MM-10-49	20 May 2025	MM-11-26	27 Jan 2025
MM-10-50	20 May 2025	MM-11-27	27 Jan 2025
MM-10-51	20 May 2025	MM-11-28	27 Jan 2025
MM-10-52	20 May 2025	MM-11-29	27 Jan 2025
MM-10-53	20 May 2025	MM-11-30	Feb 9/01
MM-10-54	20 May 2025	MM-11-31	Feb 9/01
MM-10-55	20 May 2025	MM-11-32	27 Jan 2025
MM-10-56	20 May 2025	MM-11-33	27 Jan 2025
MM-10-57	20 May 2025	MM-11-34	Jul 7/10
MM-10-58	20 May 2025	MM-11-35	Feb 28/2020
MM-10-59	20 May 2025	MM-11-36	Feb 28/2020
MM-10-60	20 May 2025	MM-11-37	27 Jan 2025
MM-10-61	20 May 2025	MM-11-38	Apr 30/14
MM-10-62	08 Dec 2025	MM-11-39	27 Jan 2025
MM-10-63	08 Dec 2025	MM-11-40	Feb 28/2020
MM-10-64	20 May 2025	MM-11-41	08 Dec 2025
MM-10-65	20 May 2025	MM-11-42	Feb 28/2020
MM-10-66	20 May 2025	MM-11-43	Jun 25/14
MM-11-1	27 Jan 2025	MM-11-44	Dec 4/15
MM-11-2	27 Jan 2025	MM-11-45	Dec 4/15
MM-11-3	27 Jan 2025	MM-11-46	27 Jan 2025
MM-11-4	Feb 9/01	MM-11-47	Feb 9/01
MM-11-5	Apr 25/13	MM-11-48	Feb 9/01
MM-11-6	Apr 25/13	MM-11-49	Feb 9/01
MM-11-7	27 Jan 2025	MM-11-50	Feb 28/2020
MM-11-8	Apr 25/13	MM-11-51	Feb 9/01
MM-11-9	27 Jan 2025	MM-11-52	Feb 9/01
MM-11-10	20 May 2025	MM-11-53	27 Jan 2025
MM-11-10.1	Dec 4/15	MM-11-54	Apr 25/13
MM-11-10.2	Apr 25/13	MM-11-55	Apr 25/13
MM-11-10.3	Apr 25/13	MM-11-56	Feb 28/2020
MM-11-10.4	Apr 25/13	MM-11-57	Feb 28/2020
MM-11-11	Feb 28/2020	MM-11-58	Feb 9/01
MM-11-12	Feb 28/2020		
MM-11-13	Apr 25/13		

# ENSTROM TH-28/480 SERIES MAINTENANCE MANUAL

## EFFECTIVE PAGE LIST

Page	Date	Page	Date
MM-11-59	Feb 28/2020	MM-12-11	27 Jan 2025
MM-11-60	Feb 28/2020	MM-12-12	Nov 15/10
MM-11-61	Jun 25/14	MM-12-13	Feb 9/01
MM-11-62	Jun 25/14	MM-12-14	Feb 9/01
MM-11-63	Feb 28/2020	MM-12-15	Feb 9/01
MM-11-64	27 Jan 2025	MM-12-16	Feb 9/01
MM-11-65	27 Jan 2025	MM-12-17	Nov 15/10
MM-11-66	Feb 28/2020	MM-12-18	Nov 15/10
MM-11-67	27 Jan 2025	MM-12-19	Nov 15/10
MM-11-68	27 Jan 2025	MM-12-19.1	Jul 3/15
MM-11-69	27 Jan 2025	MM-12-19.2	Nov 15/10
MM-11-70	27 Jan 2025	MM-12-20	Nov 15/10
MM-11-70.1	27 Jan 2025	MM-12-21	Nov 15/10
MM-11-70.2	27 Jan 2025	MM-12-22	Nov 15/10
MM-11-71	Dec 4/15	MM-12-23	27 Jan 2025
MM-11-72	Feb 9/01	MM-12-24	Feb 20/08
MM-11-73	Feb 9/01	MM-12-25	Feb 9/01
MM-11-74	Feb 9/01	MM-12-26	27 Jan 2025
MM-11-75	Aug 22/16	MM-12-27	27 Jan 2025
MM-11-76	Feb 9/01	MM-12-28	Feb 20/08
MM-11-77	Feb 9/01	MM-12-29	Feb 9/01
MM-11-78	Jul 3/15	MM-12-30	Feb 9/01
MM-11-79	Jul 3/15	MM-12-31	Jun 21/12
MM-11-80	Feb 9/01	MM-12-32	27 Jan 2025
MM-11-81	Jul 3/15	MM-12-33	27 Jan 2025
MM-11-82	Jul 3/15	MM-12-34	Nov 15/10
MM-11-83	Dec 4/15	MM-12-35	Feb 9/01
MM-11-84	Dec 4/15	MM-12-36	Feb 9/01
MM-11-85	27 Jan 2025	MM-12-37	Feb 9/01
MM-11-86	Feb 9/01	MM-12-38	Feb 9/01
MM-11-87	Feb 28/2020	MM-12-39	Feb 9/01
MM-11-88	Feb 28/2020	MM-12-40	Feb 9/01
MM-11-89	Feb 28/2020	MM-12-41	Feb 9/01
MM-11-90	Feb 28/2020	MM-12-42	Feb 9/01
MM-11-91	Feb 28/2020	MM-12-43	Aug 22/16
MM-11-92	Feb 28/2020	MM-12-44	Feb 9/01
MM-11-93	Feb 28/2020	MM-12-45	Aug 22/16
MM-11-94	Feb 28/2020	MM-12-46	Feb 9/01
MM-12-1	27 Jan 2025	MM-12-47	27 Jan 2025
MM-12-2	27 Jan 2025	MM-12-48	Feb 20/08
MM-12-3	27 Jan 2025	MM-12-49	27 Jan 2025
MM-12-4	27 Jan 2025	MM-12-50	27 Jan 2025
MM-12-5	Feb 9/01	MM-12-51	27 Jan 2025
MM-12-6	Apr 30/14	MM-12-52	27 Jan 2025
MM-12-7	Feb 9/01	MM-12-53	Feb 20/08
MM-12-8	Feb 9/01	MM-12-54	Feb 28/2020
MM-12-9	Nov 15/10	MM-12-55	Feb 20/08
MM-12-10	Nov 15/10		

# ENSTROM TH-28/480 SERIES MAINTENANCE MANUAL

## Notes:

1. This is the standard battery for the TH-28 and 480. Refer to the correct publication if an optional or special battery is installed.
2. This is the standard battery for the 480B. Refer to the correct publication if an optional or special battery is installed.
3. Refer to the following Safran Aerosystems reports for instructions for continued airworthiness:
  - a. Report DT-00013426, *Maintainability Analysis Report Enstrom B480*, latest issue.
  - b. Report DT-00013493, *Storage and Condition Requirement Sheet 480 Series*, latest issue.
  - c. Component Maintenance Publication, ENSTROM480B-F6101-00001-00, *Enstrom 480 Fuel Storage System*, latest issue.

## 2-21. Special Tools

A. The special tools listed in Table 2-3 are used for removal, installation, and overhaul of components used on the TH-28/480 Series aircraft:

### NOTE

The special tools listed in Table 2-3 are available through Enstrom's Tool Rental Program. Contact Enstrom Helicopter Product Support for details.

**Table 2-3. Special Tools**

<u>Part Number</u>	<u>Nomenclature</u>
T-0003	Main Rotor Lead/Lag Lower Nut Tool
T-0005	Damper Rod End Removal Tool
T-0009	Main Rotor Blade Bolt Guide Bullet
T-0011	Main Rotor Hoist Sling
T-0013	Main Rotor Lamiflex Nut Socket
T-0014	Needle Point Grease Adapter
T-0016	Lower Swashplate Gimbal Tool
T-0017	Transmission Hoist Eye
T-0022	Collective Spring Capsule Retainer Tool
T-0026	Main Rotor Blade Tab Bending Tool
T-0027	Main Rotor Blade Tab Angle Tool
T-0035	Oleo Disassembly Tool (Holding)
T-0036	Blade Grip Seal Installation Tool
T-0045-1	Lower Swashplate Dogleg Puller
T-0048	Main Rotor Mast Nut Tool

# ENSTROM TH-28/480 SERIES MAINTENANCE MANUAL

**Table 2-3. Special Tools**

Part Number	Nomenclature
T-0051-3	Main Rotor Flapping Nut Tool
T-0054	Swashplate Dogleg Alignment Tool
T-0056-3	Tail Rotor Thrust Bearing Retention Nut Tool
T-0057	Damper Bleeding Fixture
T-0068-3	Tail Rotor Xmsn Output Shaft Runout Tools
T-0079-1	Swashplate Swaging Tool
T-0086	Upper Guidetube Nut Tool
T-0087-15	Tail Rotor Assembly Static Balance Mandrel
T-0092-5	Taper Pin Removal Tool
T-0095	Damper Tool
T-0100-1	Swashplate DU Bushing Removal Tool
T-0102-1	Guidetube Disassembly Tool
T-0104	Swashplate Bushing Installation Tool
T-0121-1	Tail Rotor Static Balance Stand
T-0134	Plate Assembly (Lower Swashplate Assembly)
T-0135-1-SET	Main Rotor Transmission Pinion Crows Foot
T-0136-1	Clutch Removal/Installation Wrench
T-0137-1	Engine Hoist Assembly
T-0139-1	Belt Tension Tool
T-0140	Tail Rotor Rigging Tool
T-0141	Drive Pulley Alignment Tool
T-0143-1	Tail Rotor Driveshaft Alignment Tool
T-0149	Seal Installation Tool (T-T Strap)
T-0151-1	Universal Block Bearing Tool Set (Grease Lubricated)
T-0152	Tail Rotor Balance Tool (Photo Cell Bracket)
T-0160-1	Damper Ring Seal Installation Tools
T-0161-1	Seal Installation Tool
T-0162-1	Universal Block Bearing Tool (Oil Lubricated)
T-0164-1	Upper Pulley Wrench
T-0166-11	Alignment Tool, Oil Cooler Shaft

# ENSTROM TH-28/480 SERIES MAINTENANCE MANUAL

## 2-22. Torque Data

A. Unless specified in Table 2-4 and/or in this manual's maintenance procedures or as called out in the component manufacturer's specifications, all hardware should be torqued to the recommended torque values listed in Tables 2-5 through 2-14.

### NOTE

The following table does not contain all of the special torque values found in this maintenance manual.

**Table 2-4. Special Torque Values**

Location	Torque Value
<b>1. Airframe</b>	
a. Tailcone Attachment Bolts	240 in-lb/27.3 Nm
b. Landing Gear Oleo Pivot Points (all)	( <sup>1</sup> )
b. Landing Gear Leg/Drag Strut Pivot Points (all)	40-60 in-lb/4.5-6.8 Nm
<b>2. Flight Controls</b>	
a. Dogleg to Lower Swashplate Nut	40-60 in-lb/4.5-6.8 Nm
b. Dogleg to Push/Pull Rod Nut	130-140 in-lb/14.7-15.8 Nm
c. Upper Swashplate Guidetube Nuts	240 in-lb/27.3 Nm
<b>3. Main Rotor Transmission</b>	
a. Mast Nut	450 ft-lb/613.6 Nm
b. Attachment Bolt Nuts	240 in-lb/27.3 Nm
c. Pinion Nut	250 ft-lb/340.9 Nm
d. Tail Rotor Coupling Bolt	100-140 in-lb/11.3-15.8 Nm
e. Magnetic Pick-up	60-65 in-lb/6.8-7.3 Nm
<b>4. Main Rotor Hub</b>	
a. Blade Attachment Nut	50 ft-lb/67.8 Nm
b. Damper Pivot Nut	190 in-lb/21.6 Nm
c. Drag Link Nut	140 in-lb/15.8 Nm
d. Flapping Bearing Reservoir Cap	10-20 in-lb/1.1-2.3 Nm
e. Flapping Pin Nut	150-175 ft-lb/204.5-238.6 Nm
f. Lamiflex Bearing Retention Nut	5-15 in-lb/0.6-1.7 Nm
g. Lower U-block Nut	50 ft-lb/67.8 Nm
<b>5. Tail Rotor</b>	
a. Assembly Retention Bolt	300 in-lb/34.1 Nm
b. Blade Grip Bolts <sup>2</sup>	75 in-lb/8.5 Nm
c. Driveshaft Taper Pins	25 in-lb/2.8 Nm
d. Pitch Change Plate to Grip Attachment Bolts	50-70 in-lb/5.7-8.0 Nm
e. Thrust Bearing Retention Nut	80-90 ft-lb/109.1-122.7 Nm

1 Inch-Pound = 0.113 Newton Meter

1 Newton Meter = 8.851 Inch-Pound

1 Foot-Pound = 1.3558 Newton Meter

1 Newton Meter = 0.7376 Foot-Pound

<sup>1</sup> Refer to (para. 8-70.A).

<sup>2</sup> Torque for oversize bolts: 140 in-lbs/15.8 Nm maximum.

# ENSTROM TH-28/480 SERIES MAINTENANCE MANUAL

**Table 2-5. Torque Values for Nuts and Bolts**

CAUTION THE FOLLOWING TORQUE VALUES ARE DERIVED FROM OIL FREE CADMIUM PLATED THREADS.				
Thread Size	TORQUE LIMITS RECOMMENDED FOR INSTALLATION (BOLTS LOADED PRIMARILY IN SHEAR) (inch-pounds)		MAXIMUM ALLOWABLE TIGHTENING TORQUE LIMITS (inch-pounds)	
	Tension type nuts MS20365 and AN310 (40,000 psi in bolts)	Shear type nuts MS20364 and AN320 (24,000 psi in bolts)	Nuts MS20365 and AN310 (90,000 psi in bolts)	Nuts MS20364 and AN320 (54,000 psi in bolts)
<b>FINE THREAD SERIES</b>				
8-36	12-15	7-9	20	12
10-32	20-25	12-15	40	25
1/4-28	50-70	30-40	100	60
5/16-24	100-140	60-85	225	140
3/8-24	160-190	95-110	390	240
7/16-20	450-500	270-300	840	500
1/2-20	480-690	290-410	1100	660
9/16-18	800-1000	480-600	1600	960
5/8-18	1100-1300	600-780	2400	1400
3/4-16	2300-2500	1300-1500	5000	3000
7/8-14	2500-3000	1500-1800	7000	4200
1-14	3700-5500	2200-3300*	10,000	6000
1-1/8-12	5000-7000	3000-4200*	15,000	9000
1-1/4-12	9000-11,000	5400-6600*	25,000	15,000
<b>COARSE THREAD SERIES</b>				
8-32	12-15	7-9	20	12
10-24	20-25	12-15	35	21
1/4-20	40-50	25-30	75	45
5/16-18	80-90	48-55	160	100
3/8-16	160-185	95-100	275	170
7/16-14	235-255	140-155	475	280
1/2-13	400-480	240-290	880	520
9/16-12	500-700	300-420	1100	650
5/8-11	700-900	420-540	1500	900
3/4-10	1150-1600	700-950	2500	1500
7/8-9	2200-3000	1300-1800	4600	2700
The above torque values may be used for all cadmium-plated steel nuts of the fine or coarse thread series which have approximately equal number of threads and equal face bearing areas. * Estimated corresponding values.				

**Table 2-6. Fittings, Tubing**



Aluminum Alloy Tubing



Steel Tubing

Fitting Size	Tubing OD (inches)	6061-O & 5052-O Aluminum-Alloy Tube: Fitting or Nut Torque (in-lb)	Steel Tube: Fitting or Nut Torque (in-lb)
-2	1/8	20-30	75-85
-3	3/16	25-35	95-105
-4	1/4	50-65	135-150
-5	5/16	70-90	170-200
-6	3/8	110-130	270-300
-8	1/2	230-260	450-500
-10	5/8	330-360	650-700
-12	3/4	460-500	900-1000

# ENSTROM TH-28/480 SERIES MAINTENANCE MANUAL

## SECTION 3

### AIRWORTHINESS LIMITATIONS

The Airworthiness Limitations section is FAA approved and specifies inspections and other maintenance required under 14 CFR §§ 43.16 and 91.403 of the Federal Aviation Regulations unless an alternative program has been FAA approved.

For EASA approval, this Airworthiness Limitations section is approved, and variations must also be approved.

FAA APPROVED BY

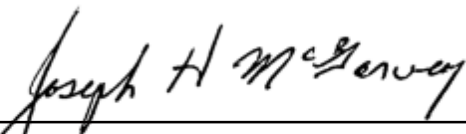
  
\_\_\_\_\_

DATE 4-30-01



MANAGER  
CHICAGO AIRCRAFT CERTIFICATION OFFICE  
CENTRAL REGION  
FEDERAL AVIATION ADMINISTRATION

# ENSTROM TH-28/480 SERIES MAINTENANCE MANUAL

## SECTION 3 LOG OF REVISIONS

Rev. Num.	Rev. Date	Pages Affected	Approval Date	FAA Approved
1	Oct 10/03	MM-3-2, MM-3-40, MM-3-41	Oct 28/03	Joe McGarvey
2	Jun 2/04	MM-3-2, MM-3-5, MM-3-13, MM-3-14, MM-3-40	Sep 8/04	Joe McGarvey
3	Oct 13/04	MM-3-2, MM-3-11 thru MM-3-18, MM-3-40	Nov 09/04	Gregory Michalik
4	Mar 15/05	MM-3-2, MM-3-8, MM-3-33, and MM-3-40	Mar 25/05	Gregory Michalik
5	Aug 4/06	MM-3-2, MM-3-7, MM-3-8, MM3-31 thru MM-3-36	Aug 30/06	Shawn Malekpour
6	Apr 16/07	MM-3-2, MM-3-15 thru MM-3-18, MM-3-31 thru MM-3-36, MM-3-39 thru MM-3-42	Apr 24/07	Shawn Malekpour
7	Feb 20/08	MM3-1 through MM-3-8	Oct 2/08	Gregory Michalik
8	N/A	None	N/A	N/A
9	Dec 12/08	MM-3-7 through MM-3-8	Mar 3/09	Gregory Michalik
10	N/A	None	N/A	N/A
11	Dec 21/09	MM-3-1, MM-3-2, MM-3-5 thru MM-3-8	Jan 6/10	Gregory Michalik
12	N/A	None	N/A	N/A
13	N/A	None	N/A	N/A
14	N/A	None	N/A	N/A
15	N/A	None	N/A	N/A
16	N/A	None	N/A	N/A
17	Jun 24/11	MM-3-6	Jul 15/11	Gregory Michalik
18	N/A	None	N/A	N/A
19	Dec 10/12	MM-3-6	Jan 10/13	Gregory Michalik
20	Apr 25/13	MM-3-1, MM-3-2, MM-3-6, MM-3-7	May 9/13	Gregory Michalik
21	Apr 30/14	None	N/A	N/A
22	Jun 25/14	None	N/A	N/A
23	Jul 3/15	None	N/A	N/A
24	Dec 4/15	MM-3-2 through MM-3-10	Dec 15/15	Gregory Michalik
25	Aug 22/16	MM-3-2, MM-3-3	Aug 26/16	Gregory Michalik
26	Feb 28/20	None	N/A	N/A
27	27 Jan 2025	MM-3-1 through MM-3-3, MM-3-5, MM-3-9	25 Feb 2025	Boubacar Felix T. Diakhite
28	20 May 2025	MM-3-2, MM-3-3	1 Aug 2025	John Raspanti
29	08 Dec 2025	MM-3-2, MM-3-3	10 Feb 2026	Boubacar Felix T. Diakhite

# ENSTROM TH-28/480 SERIES MAINTENANCE MANUAL

## SECTION 3 EASA LOG OF REVISIONS

Rev. Number	Date	EASA Approved
1	May 29/05	2005-4678
2	May 29/05	2005-4678
3	May 29/05	2005-4678
4	Sep 16/10	EASA 10031817
5	Sep 16/10	EASA 10031817
6	Sep 16/10	EASA 10031817
7	Sep 16/10	EASA 10031817
8	N/A	N/A
9	Sep 16/10	EASA 10031817
10	N/A	N/A
11	Mar 9/11	EASA 10033495, Rev. 1
12	N/A	N/A
13	N/A	N/A
14	N/A	N/A
15	N/A	N/A
16	N/A	N/A
17	May 8/14	EASA 10044744
18	N/A	N/A
19	Apr 1/14	FAA/EASA T.I.P., FAA Approved on Behalf of EASA by G. Michalik*
20	Apr 1/14	FAA/EASA T.I.P., FAA Approved on Behalf of EASA by G. Michalik*
21	May 24/17	EASA 10061805
22	N/A	N/A
23	N/A	N/A
24	Jun 22/17	FAA/EASA T.I.P., FAA Approved on Behalf of EASA by M. Javed♦
25	N/A	N/A
26	N/A	N/A
27	25 Feb 2025	FAA/EASA T.I.P. ▼
28	TBD	TBD
29	N/A	N/A

\* T.I.P., Rev. 3 dated April 23, 2013, Section 3.2.11

♦ T.I.P., Rev. 5 dated September 15, 2015, Section 3.2.11

▼ T.I.P., Rev. 7 dated October 19, 2023, Sections 3.3 and 3.5.12.4

# ENSTROM TH-28/480 SERIES MAINTENANCE MANUAL

**INTENTIONALLY LEFT BLANK**

# ENSTROM TH-28/480 SERIES MAINTENANCE MANUAL

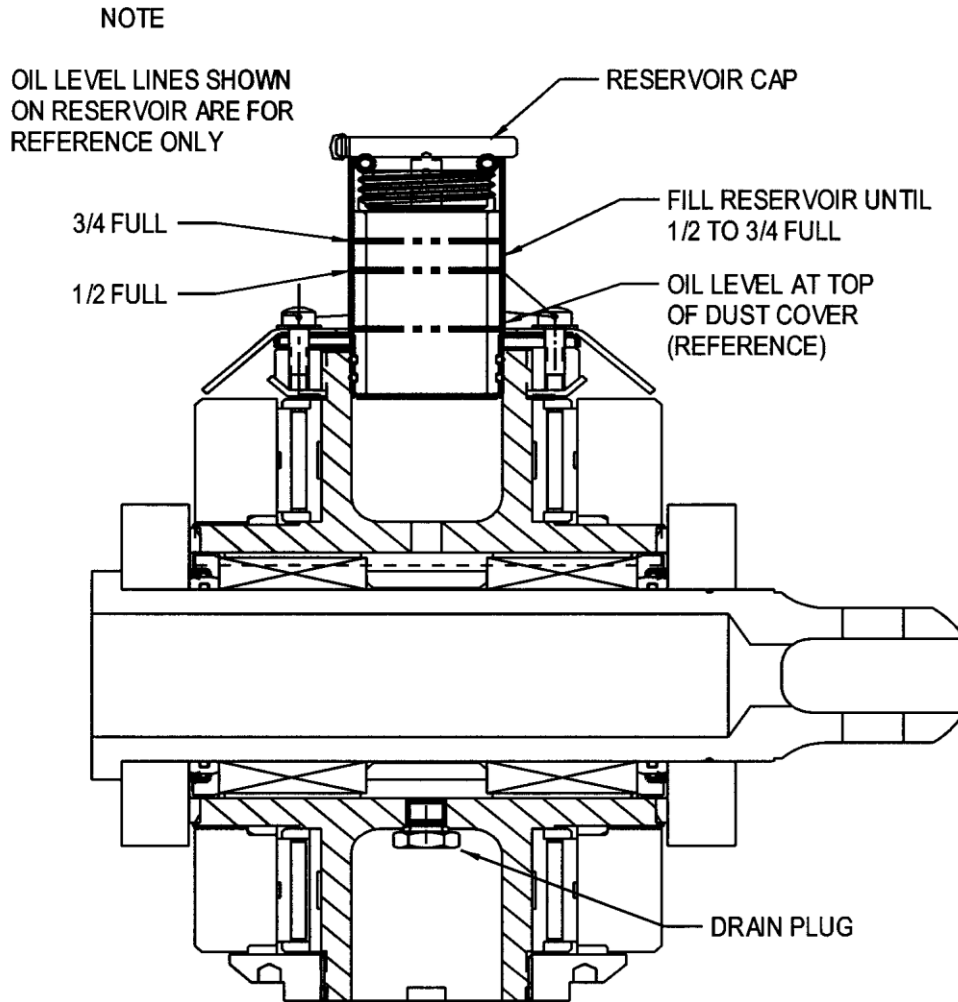
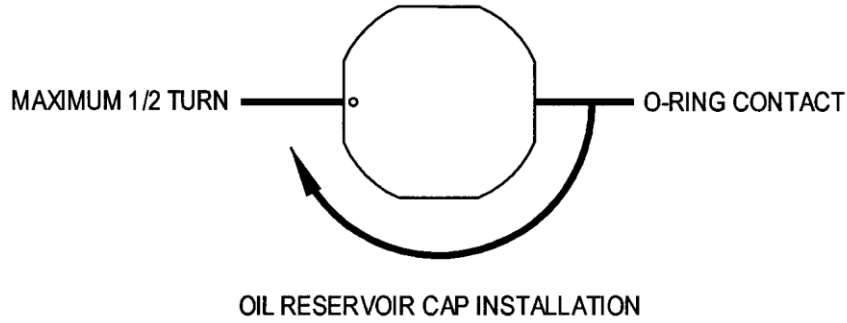

CUT AWAY VIEW OF OIL LUBRICATED FLAPPING BEARING RESERVOIR AND DRAIN PLUG

Internal Thread Oil Reservoirs

Sheet 1 of 2

Figure 4-6. Oil Lubricated Main Rotor Flapping Bearings

# ENSTROM TH-28/480 SERIES MAINTENANCE MANUAL

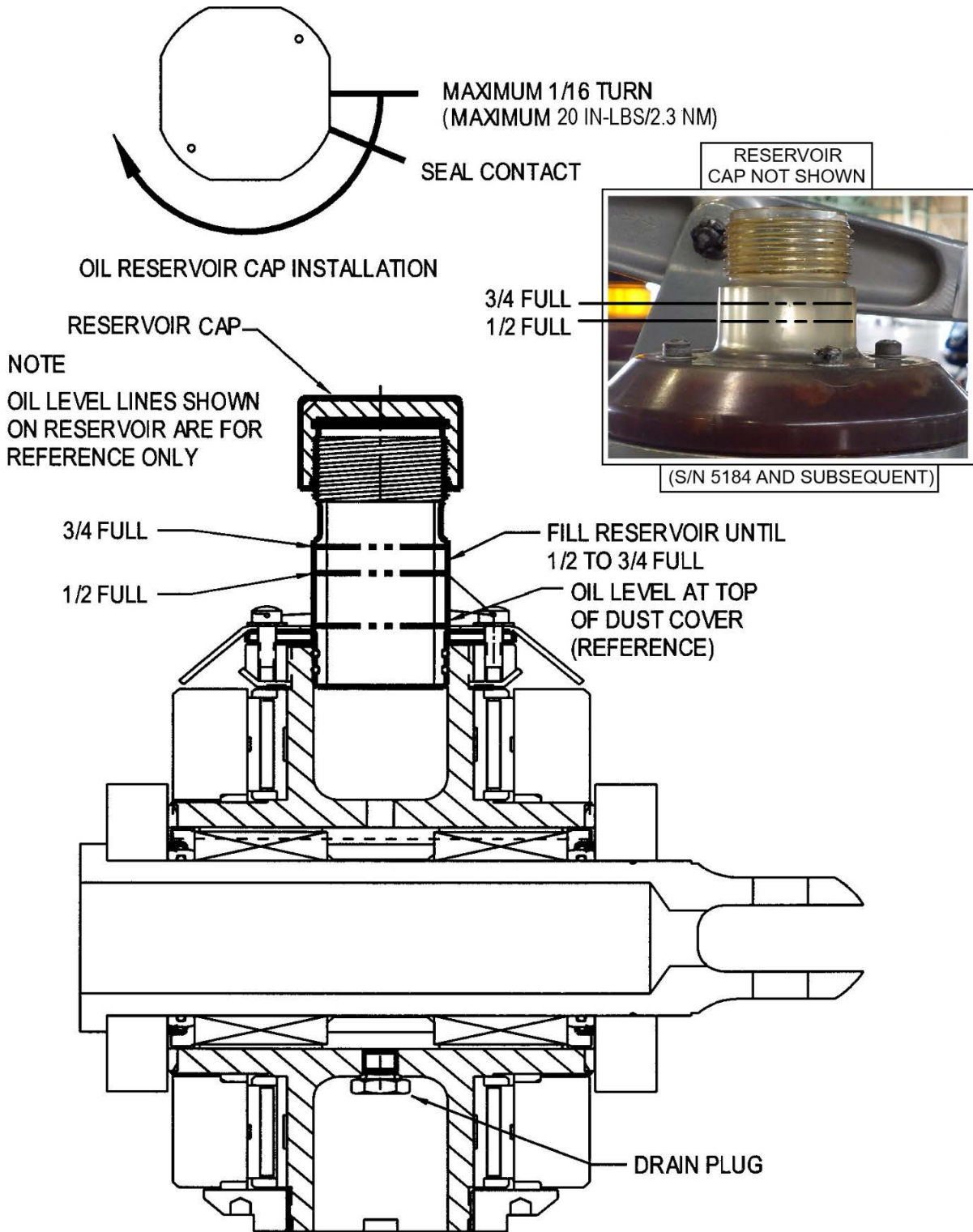

CUT AWAY VIEW OF OIL LUBRICATED FLAPPING BEARING RESERVOIR AND DRAIN PLUG

Figure 4-6. Oil Lubricated Main Rotor Flapping Bearings

# ENSTROM TH-28/480 SERIES MAINTENANCE MANUAL

## NOTE

In addition to the following aircraft preservation and storage procedures, refer to the manufacturer's instructions for on- and off-aircraft storage and revalidation procedures for the CRFS components listed in Table 4-8 (para. 4-40).

### 4-76. Low Usage - Aircraft Preservation and Storage

## NOTE

Aircraft flown for short periods several times a month.

## NOTE

Preserve the engine compressor I/A/W the Rolls-Royce 250-C20 Operation and Maintenance Manual if warranted by local corrosive conditions.

- A. Ground run the aircraft every 14 days until normal operating temperatures for the engine are obtained.
- B. Position the main rotor blades so that the tail rotor assembly is horizontal to the ground. Tie down the main rotor blades with the collective locked halfway up to relieve the steady load on the lamiflex bearings or T-T straps, as applicable.
- C. Install the main rotor hub and tail rotor assembly covers.
- D. Protect the windshields and interior equipment with suitable dust covers and/or solar shields.

## NOTE

If the interior temperature of the cabin exceeds 150°F/66°C, ventilate the cabin by opening the doors or vents.

- E. Cover the pitot and static air vents.
- F. Wash and wax the aircraft monthly to remove contaminants.
- G. Prior the next flight, complete the following:
  - (1) Remove all covers and tiedowns.
  - (2) Perform a preflight inspection.

## NOTE

When inspecting oil levels, inspect for evidence of water contamination.

- (3) If preserved, depreserve the engine I/A/W the Rolls-Royce 250-C20 Series Operation and Maintenance Manual.

# ENSTROM TH-28/480 SERIES MAINTENANCE MANUAL

## 4-77. Storage Up to 45 Days - Aircraft Preservation and Storage

- A. Complete steps A through F of paragraph 4-76.
- B. Disconnect the battery.
- C. Remove the main rotor blades.

### NOTE

Store the main rotor blades on wood racks cut out to the contour of the leading edge of the blades. Use care in handling the blades to prevent damage to the blades and trim tabs.

- D. Return the aircraft to service using the following procedures:
  - (1) Remove all covers and tiedowns.
  - (2) Connect the battery.
  - (3) Install the main rotor blades.
  - (4) Perform a preflight inspection.

### NOTE

When inspecting oil levels, inspect for evidence of water contamination.

- (5) Lubricate the aircraft I/A/W the 50 Hour requirements.
- (6) Depreserve the engine I/A/W the Rolls-Royce 250-C20 Series Operation and Maintenance Manual.

## 4-78. Storage from 45 Days to 6 Months - Aircraft Preservation and Storage

- A. Complete steps A through C of paragraph 4-77.
- B. Remove the battery and store in a cool dry area. Clean the battery shelf if required (AC 43.13-1B).

### NOTE

The aircraft may require an annual inspection.

- C. Return the aircraft to service following the procedures in step D of paragraph 4-77.

# ENSTROM TH-28/480 SERIES MAINTENANCE MANUAL

## 9-6. Main Rotor Hub

### 9-7. Removal – Main Rotor Hub

- A. Remove the main rotor blades (para. 9-34).

#### **CAUTION**

Foreign objects dropped down the mast must be immediately removed to prevent damaging the flight controls.

- B. Remove the hardware securing the pitch change bellcranks to the push-pull rods in the mast.

- C. Remove the center pivot bolts from the pitch change bellcranks. Lift the bellcranks from the mounting brackets and allow to hang free on the pitch change links.

#### **NOTE**

Install tie wraps to hold the pivot spacers in the bellcranks and the push-pull rods.

- D. Remove the safeties from the mast nut and install tool (T-0048).

#### **WARNING**

**Use extreme caution when removing the mast nut.**

- E. Remove the mast nut and the washer from the mast using the torque multiplier tool T-0197-7. If this is not available, install T-0048 tool and use a 3/4" drive electric impact wrench. If a 3/4" drive electric impact wrench is not available, install one main rotor blade and pull the breaker bar against the blade while using a large (2 kg) hammer to shock the tool (T-0048).

- F. Install the hoist sling (T-0011) so the arms are between the pitch arm and the blade retention assembly, over the lead/lag retaining nut, and outboard of the main rotor damper rod-end. The sling arms are long enough to be double wrapped if preferred (Figure 4-14).

#### **NOTE**

Install the left side ground handling wheel and extend to aid in removing the hub assembly.

- G. Attach the sling to a lifting device and slowly lift the hub assembly from the mast. The hub must be lifted exactly parallel to the mast. If there are any side loads, the hub will stick on the splines and will not come off. If the hub has been installed for a long period of time, the hub puller (T-0174-1) must be used and the control rods must be removed from inside the mast.

- H. Install the hub assembly onto a hub stand.

# ENSTROM TH-28/480 SERIES MAINTENANCE MANUAL

## 9-8. Disassembly – Main Rotor Hub (Figure 9-4 or 9-5)

- A. Remove main rotor hub from the aircraft (para. 9-7).

### NOTE

Mark all parts for reassembly in the same respective positions.

- B. Remove the pitch change links and the pitch change bellcranks from the pitch horns (para. 12-93).
- C. Remove the dampers (para. 9-26).
- D. Remove the retention assemblies (para. 9-14).
- E. Remove the hardware from the pitch change bellcrank brackets and remove the brackets (3).
- F. Remove the dust covers (4), if applicable. If the main rotor hub assembly is equipped with oil lubricated flapping bearings, remove the reservoir (Figure 9-5, 29A or 29B).

### CAUTION

The reservoir may resist removal due to the O-rings installed at the bottom. Pull up and carefully twist the reservoir until it slips out of the universal block. To prevent damage to the reservoir, do not pry on the reservoir bottom plate.

- G. Bend the locking tabs (6) out of the recesses in the retaining nuts (5). Install tool (T-0051-1 (preferred) or T-0051-3) on the nuts and remove the nuts and the washers.
- H. Turn the hub assembly over and remove the locking keys (10) from the retaining nuts (9).
- I. Using tool T-0003, remove the nuts, shims (8), and DU washers (7).
- J. Turn the hub assembly over and remove the hardware (11) from the center hub adapter.
- K. Remove the upper and lower spline adapters (12 & 18) by tapping them from the hub plates with a nylon drift.
- L. Remove the dowel pins (13) from the hub plates (14 & 17) and the center spacer (16) by tapping them through with an aluminum drift.

### WARNING

**Use extreme caution when removing or installing the blade and grip assemblies to prevent from injuring personnel.**

### WARNING

**Use protective gloves when handling heated parts.**

# ENSTROM TH-28/480 SERIES MAINTENANCE MANUAL

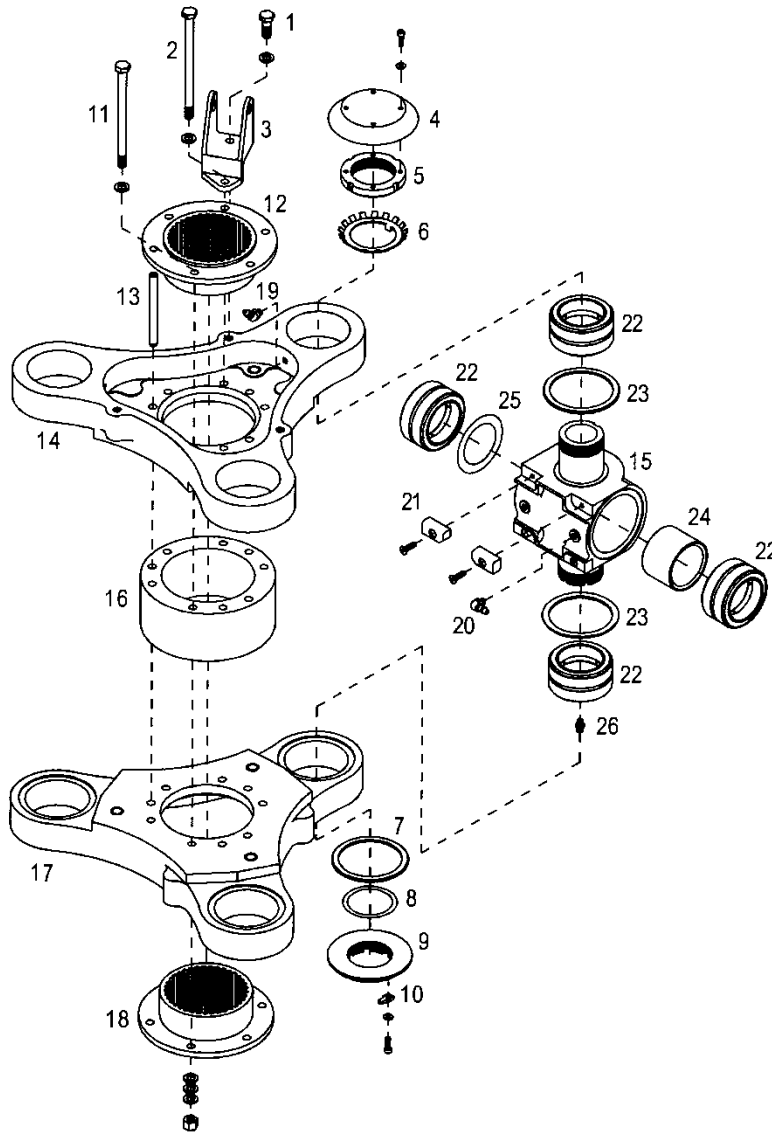

- |     |                      |     |                      |
|-----|----------------------|-----|----------------------|
| 1.  | Bolt                 | 14. | Upper Hub Plate      |
| 2.  | Bolt                 | 15. | Universal Block      |
| 3.  | Bracket              | 16. | Center Spacer        |
| 4.  | Dust Cover           | 17. | Lower Hub Plate      |
| 5.  | Retaining Nut        | 18. | Lower Spline Adapter |
| 6.  | Lock Washer          | 19. | Grease Fitting       |
| 7.  | DU Washer            | 20. | Grease Fitting       |
| 8.  | Shim                 | 21. | Stop Pad             |
| 9.  | Retaining Nut        | 22. | Bearing              |
| 10. | Lock Key             | 23. | DU Washer            |
| 11. | Bolt                 | 24. | Spacer               |
| 12. | Upper Spline Adapter | 25. | Shim                 |
| 13. | Dowel Pin            | 26. | Grease Fitting       |

Figure 9-4. Main Rotor Hub Assembly with Grease Lubricated Flapping Bearings

# ENSTROM TH-28/480 SERIES MAINTENANCE MANUAL

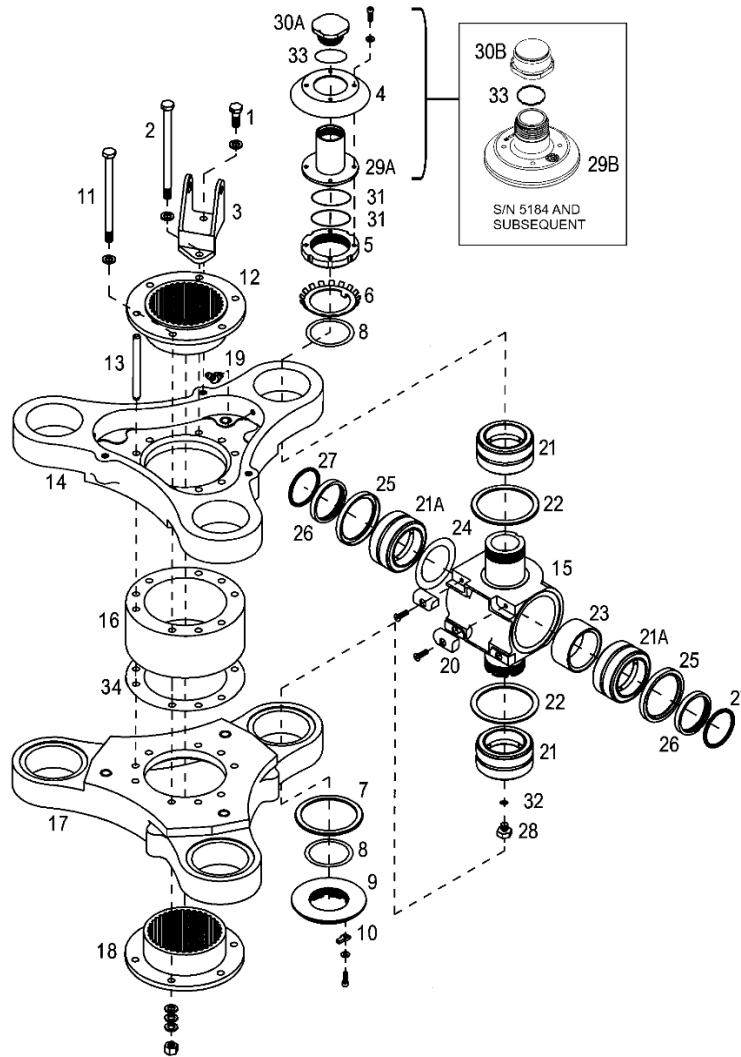

- |     |                      |        |                |
|-----|----------------------|--------|----------------|
| 1.  | Bolt                 | 19.    | Grease Fitting |
| 2.  | Bolt                 | 20.    | Stop Pad       |
| 3.  | Bracket              | 21.    | Bearing        |
| 4.  | Dust Cover           | 21A.   | Bearing        |
| 5.  | Retaining Nut        | 22.    | DU Washer      |
| 6.  | Lock Washer          | 23.    | Spacer         |
| 7.  | DU Washer            | 24.    | Shim           |
| 8.  | Shim                 | 25.    | Seal           |
| 9.  | Retaining Nut        | 26.    | Sleeve         |
| 10. | Lock Key             | 27.    | O-Ring         |
| 11. | Bolt                 | 28.    | Plug           |
| 12. | Upper Spline Adapter | 29A/B. | Reservoir      |
| 13. | Dowel Pin            | 30A/B. | Reservoir Cap  |
| 14. | Upper Hub Plate      | 31.    | O-Ring         |
| 15. | Universal Block      | 32.    | O-Ring         |
| 16. | Center Spacer        | 33.    | Seal           |
| 17. | Lower Hub Plate      | 34.    | Shim           |
| 18. | Lower Spline Adapter |        |                |

Figure 9-5. Main Rotor Hub Assembly with Oil Lubricated Flapping Bearings

# ENSTROM TH-28/480 SERIES MAINTENANCE MANUAL

D. Place the spacer (16) and shim (34), if installed, on the lower hub plate and align the bolt holes.

## NOTE

Ensure the DU washers are seated in the recessed areas of the upper hub plate.

E. Lubricate the bearing bores of the upper hub plate and install the upper hub plate onto the U-blocks.

F. Lubricate the dowel pins (13) and install by tapping them into the center hole of the 3-hole bolt pattern. Install the pins until they are slightly recessed from the surface of the hub plate.

## NOTE

The upper spline adapter has the wider flat surface on top side of the splines while the lower adapter has a rib extending from the lower end of the splines.

## CAUTION

The phasing marks on the upper spline adapter must be aligned with one of the pitch change bellcrank mount brackets. Using a felt marker, mark a line on the outboard edge of the hub plates in line with the spline phasing marks to aid in installing the lower spline adapter.

G. Insert bolts in the upper spline adapter (12) as guides and install the adapter onto the upper hub plate.

H. Carefully turn the hub assembly over and position on wood blocks.

I. Install the lower spline adapter (18) and align the phasing mark with the upper adapter phasing marks.

J. Turn the hub assembly over and install the center hub bolts (11) in the holes adjacent to the pitch change bellcrank mount bracket holes. Install the washers and nuts and torque the hardware.

K. Install the pitch change bellcrank mount brackets (3). Torque the through bolts (2). Torque and lockwire (.032) the other bolts (1).

L. Set the rotational drag of the U-blocks as follows:

- (1) Place the hub assembly on a hub stand with the lower end of the U-blocks up.
- (2) Install a DU washer (7) into the recess of the hub plate with the chamfer in board toward the hub plate.
- (3) Install shims (8) approximately .025 inch/0.6 mm thick and the lower U-block nut (9). Tighten the nut using tool (T-0003) (50 ft-lb/67.8 Nm).

# ENSTROM TH-28/480 SERIES MAINTENANCE MANUAL

- (4) Rotate the U-block to one of the stops and install a hinge pin into the retention pin hole until the inside edge of the flange is 7.1 inches/18 cm from the center of the universal block.
- (5) Place a wire loop around the hinge pin against the flange. Attach a spring scale to the wire loop and pull to check the drag. The drag tolerance with the nut torqued is 4-10 pounds/1.8-4.5 kg.
- (6) Add or subtract shims as required to obtain the proper drag.
- (7) Place the locking key (10) into the slot on the nut that is aligned with the notch in the U-block and secure with the washer and screw.

M. Turn the hub assembly over on the stand.

N. Install the upper U-block nuts (5) as follows:

## NOTE

If the hub is equipped with oil lubricated flapping bearings, shims may be required between the bearing and the lock washer to prevent the universal block from protruding above the nut. The oil reservoir flange must seat flush against the nut.

- (1) Install the lock washer (6) and nut on the U-block.
- (2) Torque the nut to 20 ft-lbs/27.3 Nm using tool (T-0051).
- (3) Tap down on the upper nut with a plastic mallet and re-torque the nut to seat the bearing. Repeat the process until the nut will not move while being re-torqued.
- (4) Bend the tab on the lock washer that aligns with the recess in the nut into the nut.
- (5) If the main rotor hub assembly is equipped with grease lubricated flapping bearings, install the dust cover (4) and secure.
- (6) If the main rotor hub assembly is equipped with oil lubricated flapping bearings:
  - a. Install new O-rings (31) on the reservoir (29A or 29B). Lubricate the O-rings with MIL-PRF-23699.
  - b. Install the reservoir (29A or 29B) onto the universal block (15) using a twisting motion until the base of the reservoir seats flat against the universal block.

## CAUTION

Ensure the reservoir is fully seated into the universal block before installing the screws. Do not attempt to seat the reservoir into the universal block by using the screws. The reservoir will distort and crack.

- c. Install dust cover (4), if applicable, and secure. Ensure seal (33) is present, install caps (30A or 30B), and safety (MS20995C32).

# ENSTROM TH-28/480 SERIES MAINTENANCE MANUAL

## NOTE

The locking key must be aligned with the piston slots for the jam nut to seat against the piston shaft.

T. Hold the damper bearing with a wrench and tighten the jam nut when the correct position is set. Lockwire (.032) the jam nut to the locking key (18). Position the locking key towards the top of the damper.

U. Lockwire (.032) the end cap bolts (17) in pairs and the valve caps (23) to the reservoir bolts (28) in pairs. Lockwire (.025) the bleed plugs (26) in a pair.

## 9-31. Installation – Dampers (Figure 9-16)

A. Install the damper onto the main rotor hub.

B. Install the chamfered washer (2) onto the inboard pivot bolt (1) with the chamfer against the bolt head.

C. Install the inboard pivot bolt (1) through the hub plates and damper. Install the washer (3) and nut (4) but do not torque.

## CAUTION

On hydraulic dampers, the locking key in the piston shaft must be on the top side to prevent interference with the hinge pin.

D. Install the spacers (7) on each side of the damper bearing and slide the damper bearing into the hinge pin.

E. Align the damper bearing and spacers with the hinge pin. Install a washer (6) on the bolt (5) and install the bolt (5). Install two washers (6) and the nut (8). Torque to 450-500 in-lb/45.5-56.8 Nm and install a cotter pin (9).

F. Torque the inboard pivot bolt (1) to 190 in-lb/21.6 Nm.

G. If the washers and nut were removed from pitch change bellcrank center bolt in accordance with step C, remove the center pivot bolt, turn the bolt 180°, and reinstall the bolt and install washers and nut. Torque to 40 in-lb/4.5 Nm and cotter pin.

H. Perform a maintenance test flight (para. 4-61).

# ENSTROM TH-28/480 SERIES MAINTENANCE MANUAL

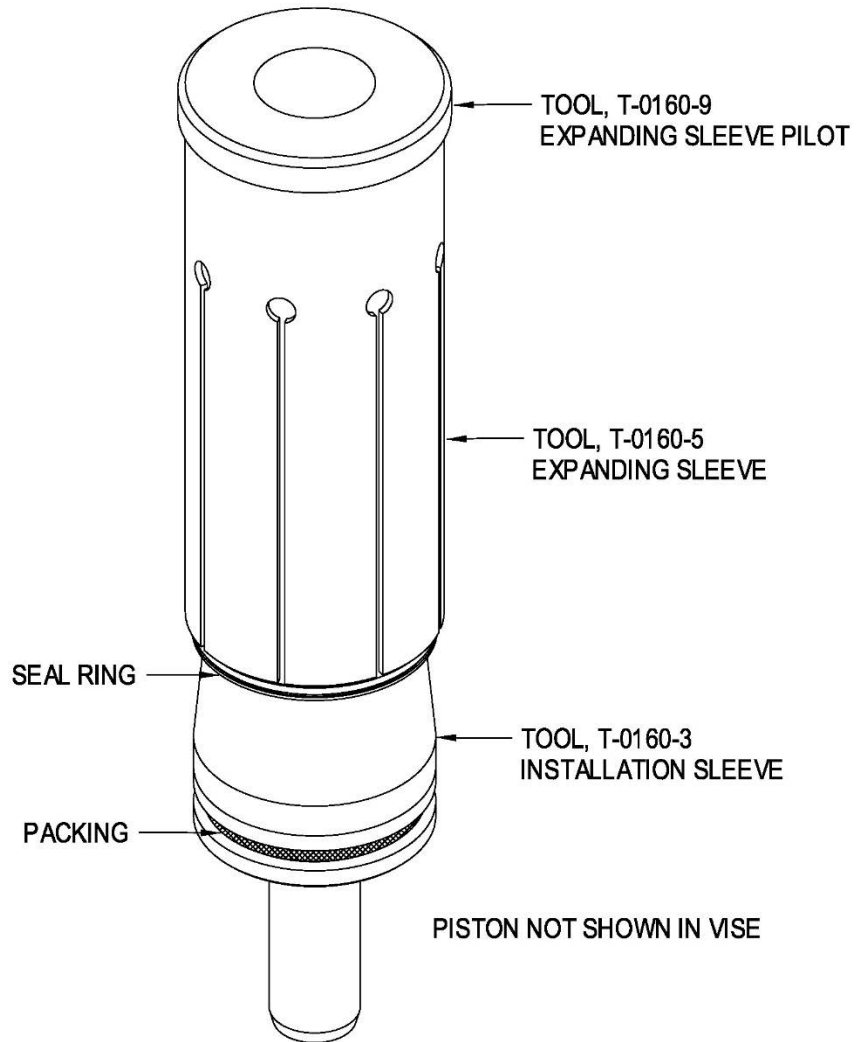
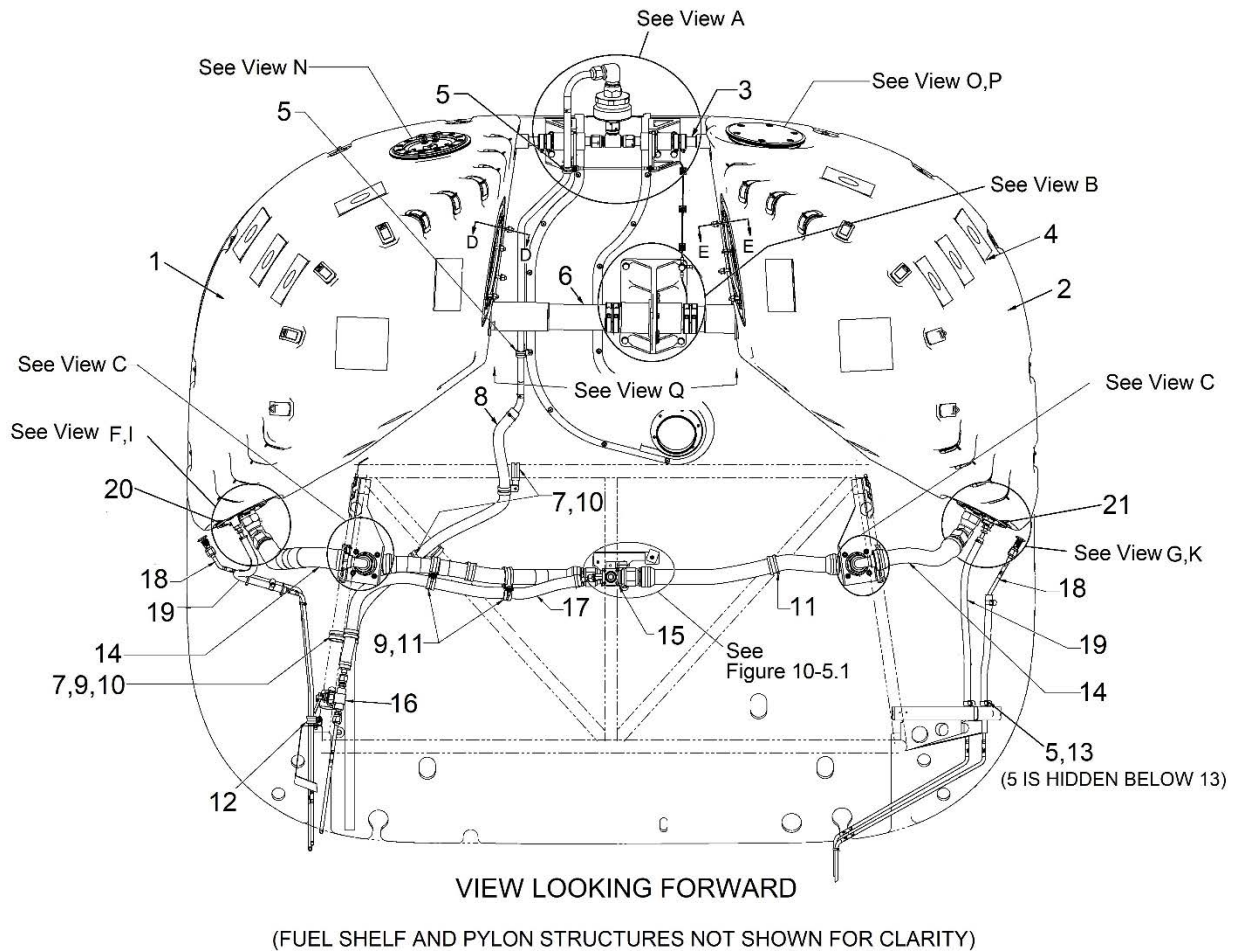

Figure 9-18. Seal Ring Installation

# ENSTROM TH-28/480 SERIES MAINTENANCE MANUAL



- |     |                              |     |                             |
|-----|------------------------------|-----|-----------------------------|
| 1.  | Left Fuel Bladder            | 12. | Clamp                       |
| 2.  | Right Fuel Bladder           | 13. | Clamp                       |
| 3.  | Overboard Crossover Vent     | 14. | Fuel Line                   |
| 4.  | Velcro (self-gripping) patch | 15. | Shutoff Valve Assembly      |
| 5.  | Clamp (size 8)               | 16. | Shutoff Drain Valve         |
| 6.  | Fuel Cross Fill              | 17. | Shutoff Valve Drain Line    |
| 7.  | Clamp (size 12)              | 18. | Scupper Drain Line          |
| 8.  | Vent Tube Assembly           | 19. | Sump Drain Line             |
| 9.  | Clamp (size 14)              | 20. | Left Flange Plate Assembly  |
| 10. | Clamp (size 16)              | 21. | Right Flange Plate Assembly |
| 11. | Clamp (size 18)              |     |                             |

Sheet 1 of 5

Figure 10-2.1. CRFS Fuel Cell Assembly and Installation

# ENSTROM TH-28/480 SERIES MAINTENANCE MANUAL

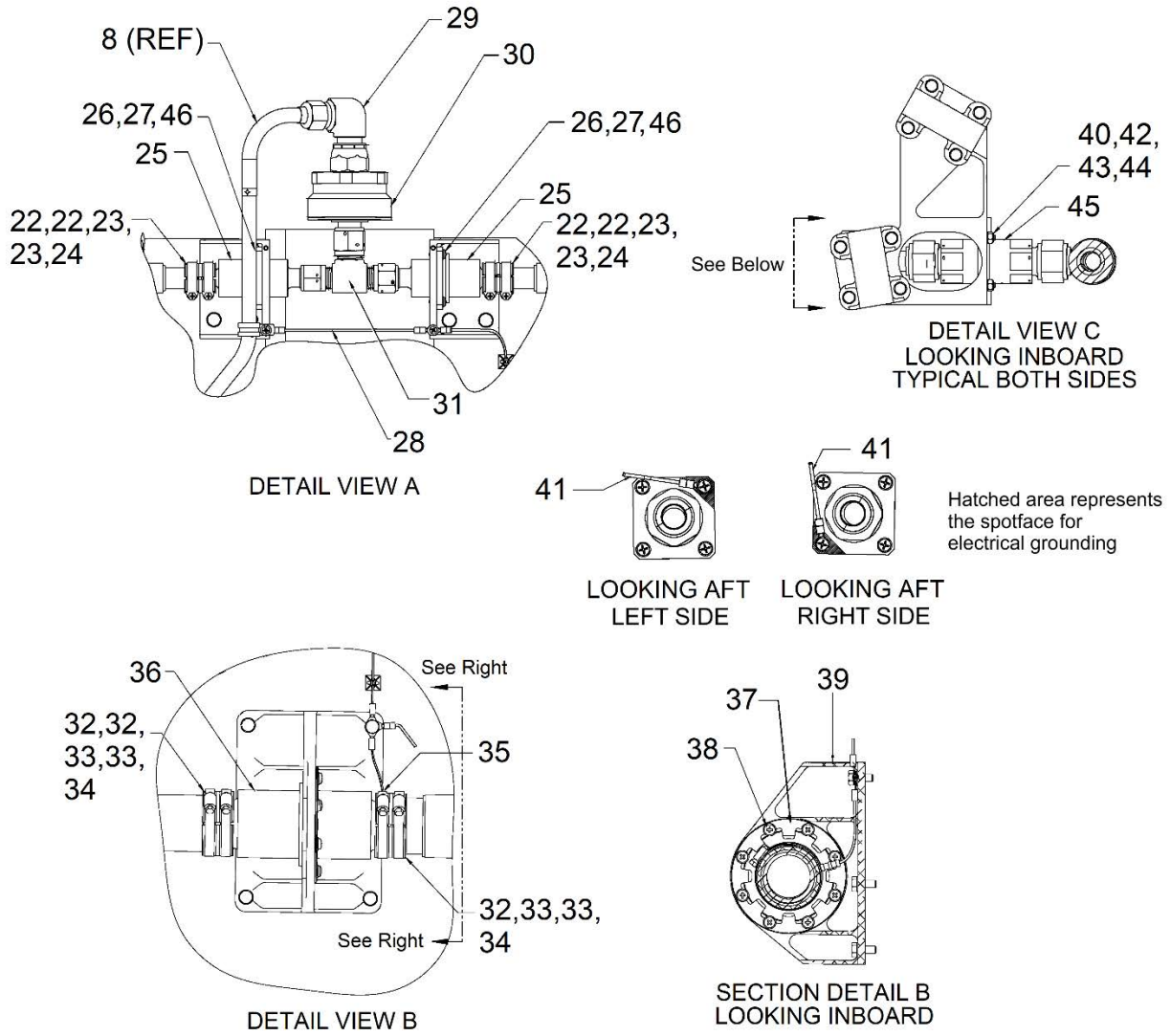

- |     |                               |     |                                     |
|-----|-------------------------------|-----|-------------------------------------|
| 22. | Hose Clamp                    | 35. | Ground Clamp Assembly               |
| 23. | Half Clamp                    | 36. | Cross Fill Breakaway Valve Coupling |
| 24. | O-ring                        | 37. | Frangible Ring                      |
| 25. | Vent Breakaway Valve Coupling | 38. | Screw                               |
| 26. | Screw                         | 39. | Coupling Bracket Assembly           |
| 27. | Washer                        | 40. | Screw                               |
| 28. | Ground Strap                  | 41. | Ground Strap                        |
| 29. | Fitting                       | 42. | Washer                              |
| 30. | Roll Over Valve Assembly      | 43. | Washer                              |
| 31. | Tee Fitting                   | 44. | Nut                                 |
| 32. | Clamp                         | 45. | Fuel Line Breakaway Valve Coupling  |
| 33. | Half Clamp                    | 46. | Lock Washer                         |
| 34. | O-ring                        |     |                                     |

Sheet 2 of 5

Figure 10-2.1. CRFS Fuel Cell Installation and Assembly

# ENSTROM TH-28/480 SERIES MAINTENANCE MANUAL

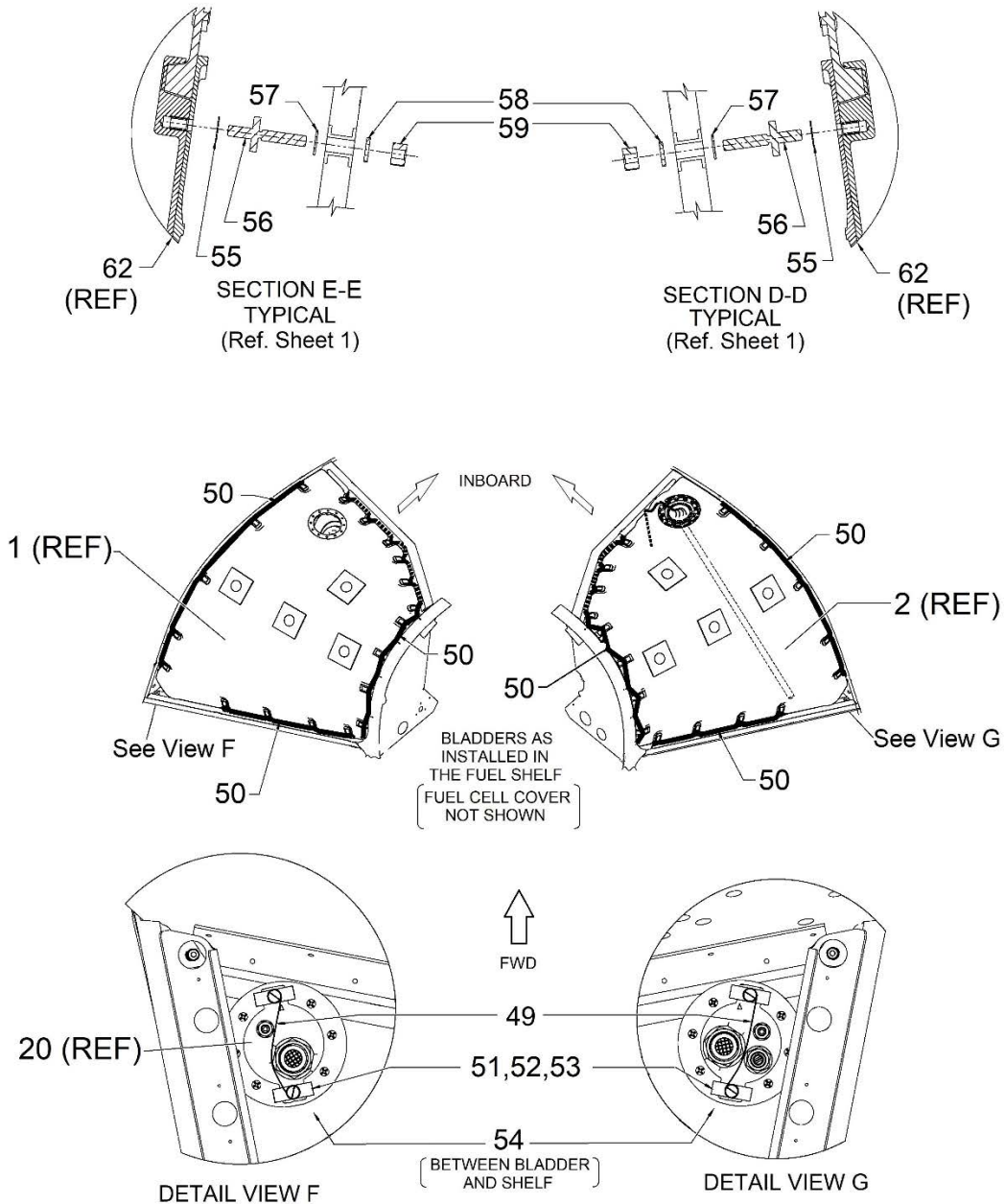

- |     |                   |     |                |
|-----|-------------------|-----|----------------|
| 49. | Lockwire          | 55. | Washer         |
| 50. | Lacing (Paracord) | 56. | Frangible Stud |
| 51. | Frangible Tab     | 57. | Nylon Washer   |
| 52. | Bolt              | 58. | Washer         |
| 53. | Washer            | 59. | Nut            |
| 54. | Flow Diverter     |     |                |

Sheet 3 of 5

Figure 10-2.1. CRFS Fuel Cell Installation and Assembly

# ENSTROM TH-28/480 SERIES MAINTENANCE MANUAL

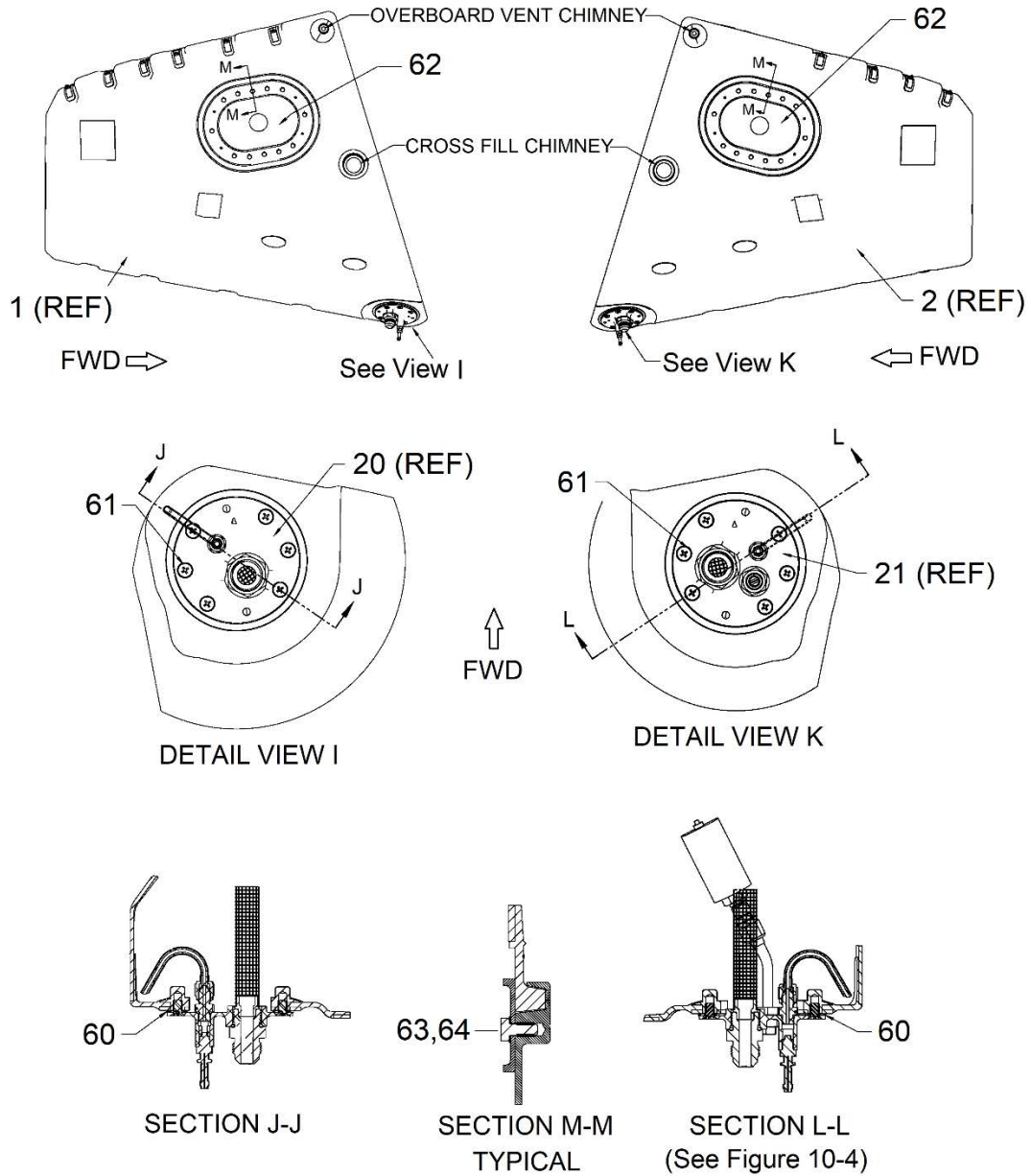

- 60. Gasket
- 61. Screw
- 62. Access Door (Inner Flange and Outer Ring)

- 63. Bolt
- 64. Washer

Figure 10-2.1. CRFS Fuel Cell Installation and Assembly

# ENSTROM TH-28/480 SERIES MAINTENANCE MANUAL

## CAUTION

Use a backing wrench when installing or removing fluid lines and fittings to prevent damage.

- I. Disconnect the supply line from the fuel cell fitting.
- J. Disconnect the sump drain line from the drain valve.
- K. Remove the bolts and washers from the plate that secures the fitting assembly to the fuel cell structure.
- L. Remove the fuel cell from the fuel cell structure.
- M. Once the fuel cell is removed, wipe out any fuel residue and miscellaneous hardware from the cavity of the fuel cell structure.
- N. Do not apply oil to the fuel bladder if moving the fuel cell to long term storage. Store removed fuel cells in a bag or box to protect the rubber from UV, ozone, heat, and/or humidity.

## 10-4.2 Removal – Fuel Cell, Aerazur Fuel Bladder System

### NOTES

If practicable, removal of the fuel cells should occur when the ambient temperature is at least 70°F/21°C.

Removal procedures are the same for both fuel cells unless otherwise noted.

- A. Defuel the aircraft (para. 4-5).
- B. Remove the upper plenum/air inlet (para. 13-28).
- C. Remove the air deflector from the top of the cabin.
- D. Remove the fuel cell cover (para. 8-14).
- E. Disconnect the electrical connectors for the fuel quantity probe and the low fuel warning switch from the right-side fuel cell.

### NOTE

Cover all open ports and lines to prevent contamination of the fuel system.

- F. Disconnect the fuel crossover line (para. 10-15.2).
- G. Disconnect the overboard vent crossover line (para. 10-15.2).

# ENSTROM TH-28/480 SERIES MAINTENANCE MANUAL

## CAUTION

Use a backing wrench when installing or removing fluid lines and fittings to prevent damage.

- H. Disconnect the supply line from the fuel cell fitting.
- I. Disconnect the sump drain line from the drain valve.
- J. Unlace the fuel cell from the supports.
- K. Remove the fuel cell from the fuel cell structure.

### 10-4.3 Removal – Fuel Cell, CRFS (Figure 10-2.1)

## NOTES

If practicable, removal of the fuel cells should occur when the ambient temperature is at least 70°F/21°C. Refer to the manufacturer's instructions for additional handling and storage recommendations for the fuel cell (Table 2-2).

Removal procedures are the same for both fuel cells unless noted otherwise.

- A. Defuel the aircraft (para. 4-5).
- B. Remove the upper plenum/air inlet (para. 13-28).
- C. Remove the air deflector.
- D. Remove the fuel cell cover (para. 8-14).
- E. Disconnect the electrical connectors for the fuel quantity transmitter and the low fuel warning switch if removing the right-side fuel bladder (2).

## NOTE

Cover all open ports and lines to prevent contamination of the fuel system.

## CAUTION

Use care when removing components connected to the breakaway valve couplings.

- F. Disconnect the overboard crossover vent line (3).
  - 1) Remove the hose clamps (22), half clamps (23), and O-ring (24) between the breakaway valve coupling (25) and the vent chimney of the bladder (1 or 2) to be removed.

# ENSTROM TH-28/480 SERIES MAINTENANCE MANUAL

G. Disconnect the cross fill fuel line (6):

- 1) Remove the hose clamps (32), half clamps (33), and O-ring (34) between the breakaway valve coupling (36) and the cross fill chimney of the bladder (1 or 2) to be removed.

## CAUTION

Use a backing wrench when installing or removing fluid lines and fittings to prevent damage.

H. Disconnect the fuel supply line (14) from the flange plate fitting (20 or 21).

I. Disconnect the sump drain line (19) from the sump drain valve (12, Figure 10-4).

J. Disconnect the fuel bladder from the fuel cell structure.

- 1) Remove the lacing cords (50) (3 cords) that attach the bladder to the structure.

## CAUTION

Use caution when removing frangible hardware.

- 2) Remove the frangible tabs (51) from the flange plate assembly (20 or 21) (2 places) by removing the bolts (52) and washers (53).

## CAUTION

Support the fuel cell when removing the frangible stud hardware.

- 3) Remove the nuts (59) and washers (58) that secure the frangible studs (56) (4 places).

K. Remove the fuel bladder (1 or 2) from the fuel cell structure.

L. Once the fuel bladder is removed, wipe out any fuel residue and miscellaneous hardware from the cavity of the fuel cell structure.

M. Refer to the manufacturer's publications for CRFS fuel bladder storage requirements. (Refer to Table 2-2.)

## 10-5. Inspection – Fuel Cells

A. Inspect the fuel cells for loose seams, cuts, abrasions, scuffed surfaces, tears, blisters, and for any area that appears to have become soaked with fuel.

- 1) Before removing a fuel cell, isolate areas of possible leaks by tracing the wetness or staining as far as visibly possible.

# ENSTROM TH-28/480 SERIES MAINTENANCE MANUAL

- B. Inspect fittings, flanges, access doors, and inserts for damage and security.
- C. Check gaskets for tightness and ensure no gasket cement has been used.
- D. Check all hose clamped connections for tightness, damage, and leaks.
- E. CRFS: Perform general and detailed inspections I/A/W the manufacturer's instructions.
  - 1) If fuel cell cover is removed, check lacing attachments and Velcro (self-gripping) patches for damage and security.

## 10-6. Repair – Fuel Cells

- A. Repair the fuel cells I/A/W the manufacturer's instructions.
- B. Replace fittings that are damaged beyond repair.
- C. Repair inserts I/A/W the manufacturer's instructions.

## 10-7. Replacement – Fuel Cells

### NOTE

For replacing the standard fuel cell, proceed to paragraph 10-7.1. For replacing the Aerazur fuel cell, proceed to paragraph 10-7.2. For replacing the CRFS fuel cell, proceed to Para. 10-7.3.

### 10-7.1 Replacement – Fuel Cell, Standard Fuel System

#### NOTES

Refer to the *TH-28/480 Series Illustrated Parts Catalog* for authorized bladder part numbers for the standard fuel system.

Replacement procedures are the same for both fuel cells unless noted. Replace all used packings/O-rings.

Cover all open ports and lines to prevent contamination of the fuel system.

The foam assembly is installed in the replacement fuel cells.

- A. Prepare the replacement fuel cell (1 or 2, Figure 10-2) as follows:
  - 1) If installing a new foam assembly, refer to SIL T-054, latest revision. Prior to installing the foam, inspect the bladder cavity for debris.
  - 2) Ensure that the captive nut plate threads are free of debris or sealant and ensure that the sealing surfaces are clean and dry.

# ENSTROM TH-28/480 SERIES MAINTENANCE MANUAL

- 3) Install oval flange plate (4):
  - a) Install a new gasket (3). If needed, install 2 to 4 studs, hand tight, into the flange ring to hold the gasket in place on the fuel cell. (The studs are made by removing the heads from appropriate length AN4-XXA bolts and deburring the cut shank.)
  - b) Install the oval flange plate (4) (raised surface forward) with bolts (6) and washers (5). Torque (25-30 in-lb/2.8-3.4 Nm) in a crisscross torque pattern (for 24 bolts), making three full rounds to ensure proper gasket seating. Remove the studs as required when installing the bolts and washers.
  - c) Ensure that there is no movement of the washers. If there is movement, back out the bolt and recheck the threads for debris or sealant. Re-install and torque.
- B. Remove the screws (8) that secure the fuel fitting assembly (7) to the fuel cell (1 or 2).
- C. Partially separate the fuel fitting assembly from the fuel cell to access the syphon tube assembly nut coupling.
- D. Loosen the nut coupling, then pivot the syphon tube toward the fuel strainer.
- E. Remove the fuel fitting assembly from the fuel cell. The low fuel warning switch will be mounted on the fuel fitting assembly for the right fuel cell.
- F. Position the fuel fitting assembly onto the replacement fuel cell such that the sump drain valve it is oriented toward the low corner of the fuel cell. Pivot the end of the syphon tube to the low corner. Torque the nut coupling (50-65 in-lb/5.6-7.3 Nm).
- G. Install the screws to secure the fuel fitting assembly to the fuel cell and torque to 25-30 in-lb/2.8-3.4 Nm.
- H. Remove the hardware securing the fuel quantity probe mounting flange (12 or 31) to the fuel cell and remove the fuel quantity probe mounting flange and probe. (The fuel quantity probe remains installed on the mounting flange.) Note the position of the fuel quantity probe.
- I. Install new gasket (30) and install the mounting flange (12 or 31) on the replacement fuel cell. Torque the hardware to 25-30 in-lbs/2.8-3.4 Nm.
- J. Allow several hours (preferably overnight) after installation of the oval flange plate (4), fuel fitting assembly and mounting flange components and retorque the hardware.
- K. Safety wire as required.

# ENSTROM TH-28/480 SERIES MAINTENANCE MANUAL

## 10-7.2 Replacement – Fuel Cell, Aerazur Fuel Bladder System

### NOTES

Replacement procedures are the same for both fuel cells unless noted. Replace all used packings/O-rings.

Cover all open ports and lines to prevent contamination of the fuel system.

A. Remove the drain valve from the fuel cell. Clean the threads on the drain valve. Coat the threads with sealant (Permatex #1C) and install the valve into the replacement fuel cell.

B. Remove the supply line fitting from the fuel cell. Replace the packing and install the fitting into the replacement fuel cell.

C. Remove the access plates (zippers) from the fuel cell.

D. Remove the strainer assembly installed in the bottom of the fuel cell over the supply line outlet and install in the replacement fuel cell.

E. Remove the fuel quantity probe and the low fuel warning switch from the right fuel cell and install into the replacement fuel cell (para. 10-48.3 and 10-51.3).

### NOTE

Ensure that the lacing cord used to secure the internal baffles in the bladder does not interfere with the access plates (zipper) during installation of the plates (zipper). The plates (zipper) will not seal if this occurs.

F. Reinstall the access plates (zippers) and torque the installation hardware to 40-50 in-lbs/4.5-5.7 Nm.

## 10-7.3 Replacement – Fuel Cell, CRFS

### NOTES

Only replace a CRFS fuel bladder with another CRFS fuel bladder.

Refer to the manufacturer's instructions for preparing a fuel bladder if it was removed from packaging and/or from long term storage. (Refer to Table 2-2.)

The following procedures are the instructions for transferring the sump, fuel filler port, and fuel quantity transmitter assemblies between fuel bladders.

Replacement procedures are the same for both fuel cells unless noted. Replace all used packings/O-rings.

# ENSTROM TH-28/480 SERIES MAINTENANCE MANUAL

## NOTES

Cover all open ports and lines to prevent contamination of the fuel system.

Refer to Figure 10-2.1 for numbered items.

- A. If applicable, remove the fuel quantity transmitter (79) and flanged cup (74) from the right-side bladder (2):
- 1) Remove the transmitter (79) I/A/W para. 10-48.4.
  - 2) Remove bolts (75) and washers (76) (6 places) that secure the flanged cup (74) to the fuel bladder.
- B. Remove the access door (62) from the bladder (1 or 2) being replaced:
- 1) Remove nylon washers (57), frangible studs (56), and washers (55) (4 places) from the access door (62).
  - 2) Remove bolts (63) and washers (64) (12 places) that secure the outer ring and inner flange to the bladder.

## CAUTION

During removal, hold the central handle to prevent the inner flange from falling into the cavity and causing damage to the interior of the bladder cavity.

- C. Remove the flange plate assembly (20 or 21) from bladder (1 or 2) being replaced:
- 1) Remove screws (61) (6 places) that secure the flange plate assembly (20 or 21) to the bladder.

## NOTE

To facilitate access to the syphon B-nut, it may be helpful to remove the fuel strainer assembly. Refer to Figure 10-4 for numbered components in steps 2 and 3.

- 2) Access the syphon (5) through the bladder side opening and loosen the B-nut coupling, then pivot the syphon tube toward the fuel strainer assembly (15).
  - 3) Remove the flange plate assembly (2) from the fuel cell. The low fuel switch (10) will be mounted on the flange plate assembly for the right fuel cell.
- D. Prepare the replacement fuel bladder (1 or 2) as follows:
- 1) Ensure that any captive nut plate threads are free of debris and ensure that the sealing surfaces are clean and dry.
  - 2) Ensure that the fuel bladder cavity is free of debris.

# ENSTROM TH-28/480 SERIES MAINTENANCE MANUAL

- E. Install the flange plate assembly (20 or 21) in the replacement fuel bladder (1 or 2):
- 1) Install gasket (60) between bladder and flange plate assembly (20 or 21).

## NOTE

Refer to Figure 10-4 for numbered items in steps 2 through 4.

- 2) Insert flange plate assembly (2) into the bladder opening so that the sump drain valve (12) is turned toward the low corner of the fuel cell and the arrow points forward. The syphon tube (5) should be loose to allow it to pivot within the bladder cavity and ease insertion of the assembly into the bladder.
- 3) Align the syphon tube (5) to face the lower corner of the bladder and secure the syphon in position:
  - a) Verify torque on the syphon tube sump fitting (4) (40-65 in-lb/4.5-7.3 Nm).
  - b) Grip the flanged plate assembly (2) with a 1-3/8 inch wrench.
  - c) Access the syphon B-nut through the bladder opening and torque (50-65 in-lb/5.6-7.3 Nm).
- 4) Install new O-ring (14) and the fuel strainer assembly (15), if required (300-500 in-lb/33.9-56.5 Nm).
- 5) Install the screws (61) (6 places) to secure the flange plate assembly (20 or 21) to the fuel bladder. Torque to 50-55 in-lb/5.6-6.2 Nm.

F. If required, install the fuel quantity transmitter flanged cup (74) in the replacement fuel bladder (2).

- 1) Install new gasket (73) on bladder ring.
- 2) Install flanged cup (74) by aligning the bolt pattern and the "FWD" mark.
- 3) Install bolts (75) and washers (76) (6 places). Torque (50-55 in-lb/5.6-6.2 Nm).

G. Install access door (62):

- 1) Install inner flange and outer ring with bolts (63) and washers (64) (12 places). Torque (25-30 in-lb/2.8-3.4 Nm).
- 2) Install washers (55) and frangible studs (56) (4 places). Torque (25-30 in-lb/2.8-3.4 Nm).

H. Cover all open ports to prevent contamination of the bladder.

I. Allow several hours (preferably overnight) after installation of access door, flange plate assembly, and fuel quantity transmitter cup (if applicable) and retorque the hardware.

# ENSTROM TH-28/480 SERIES MAINTENANCE MANUAL

- I. Install the fuel cell covers (para. 8-17).
- J. Install a filler port gasket between the fuel cell the fuel cell cover and one between the fuel cell cover and the filler port. Install the hardware and torque to 40-50 in-lb/4.5-5.7 Nm.
- K. Install the air deflector on the top of the cabin.
- L. Install the upper plenum/air inlet (para. 13-31).
- M. Service the fuel cells (para. 4-4) and check for leaks.
- N. Check for proper operation of the fuel quantity system (para. 7-85) and the low fuel warning system (para. 10-41). If applicable, install the cover for the fuel quantity probe after determining that the fuel quantity system is operating properly.
- O. Bleed the fuel system I/A/W the Rolls-Royce 250-C20 Series Operation and Maintenance Manual.

## 10-8.3 Installation – CRFS Fuel Cell

### NOTES

Installation procedures are the same for both fuel cells unless noted. Refer to Figure 10-2.1 for numbered items.

The bladders are previously assembled with the fuel transmitter flange cup and flange plate assemblies installed. If not assembled with those assemblies, refer to the applicable replacement step in Para. 10-7.3 to install the component.

Replace all used packings/O-rings.

Use a temporary protective barrier (such as masking tape) on the fuel tank compartment protrusions and edges to prevent damage to the external wall of the flexible fuel tank.

- A. Ensure sealing surfaces are dry.
- B. Set the fuel bladder (1 or 2) into the support structure. Align the bladder with the access door frangible stud openings, cross fill opening, vent opening, hook and loop patches, and flanged plate assembly opening. Ensure an even gap around the vent and cross fill chimneys and the flange plate assembly fuel shelf opening.
- C. If not present, install the flow diverter (54) for the interface between the flange plate assembly (20 or 21) and the surface of the fuel shelf compartment.
- D. Attach the access door frangible studs (56) to the inboard fuel shelf wall:
  - 1) Install nylon washer (57) over frangible stud (56) and insert studs through fuel shelf wall (4 places).
  - 2) Install washers (58) and nuts (59) on the frangible studs (56). Do not fully tighten at this step.

# ENSTROM TH-28/480 SERIES MAINTENANCE MANUAL

## NOTE

Ensure a gap around all sides of the frangible tab and structure.

E. Install frangible tabs (51) with bolts (52), and washers (53) (2 places). Do not fully tighten at this step.

F. Right-side fuel bladder (2): Install fuel quantity transmitter (79) (para. 10-51.4, steps A through E).

G. Left-side fuel bladder (1): Cover the fuel filler port to help seal the bladder for the next step if a cover is not already installed.

H. Install lacing cords (50), 3 places:

- 1) Install lacing cords (50). The cords may be installed in any order.
- 2) Pull lacing cord (50) tight to remove slack.
- 3) Tie off the ends of lacing cord using a figure 8 type knot or similar non-slip type of knot.

I. Fully tighten hardware from steps D and E.

- 1) Access door frangible door stud nuts (59): Torque 7 in-lb/0.8 Nm.
- 2) Frangible tab bolts (52): Torque 50-55 in-lb/5.6-6.2 Nm and lockwire (49) (MS20995C25).

## CAUTION

Use a backing wrench when installing or removing fluid lines and fittings to prevent damage.

## CAUTION

Use caution when installing components connected to the breakaway valve couplings.

J. Connect the sump drain line (19) to the sump drain valve (12, Figure 10-4).

## NOTE

Hold the elbow by the flats to assist installation of the fitting to the flange plate assembly.

K. Connect the cross fill breakaway valve coupling (36) (para. 10-18.5, A).

# ENSTROM TH-28/480 SERIES MAINTENANCE MANUAL

- L. Connect the fuel supply line (14) to the flange plate assembly (20 or 21).

## NOTE

Inspect the chimneys for restrictions and damage before connecting the overboard vent crossover and fuel cross fill.

- M. Connect the vent breakaway valve couplings (25) (para. 10-18.5, B).

- N. Connect the electrical connectors for the fuel quantity transmitter and the low fuel warning switch in the right-side fuel bladder (2).

- O. Allow several hours (preferably overnight) after the fuel cell has been completely installed and retorque the hardware.

- P. Install the fuel cell covers (para. 8-17).

- Q. Install the fuel cap assembly (70):

- 1) Remove the temporary fuel port cover.

## NOTE

Check that gasket (65) is present. It may be present either adhered to the fuel cell cover or to the underside of the frangible ring (68).

## NOTE

To facilitate alignment and installation of the gaskets, flange, and frangible cover, a light coat of spray adhesive may be used as a temporary aid to maintain alignment during installation. Apply spray adhesive (Super 77 or equivalent) to one side of the gaskets (66) and (65, if required). Lightly tack on gasket (66) to the bottom of the flange (67) and to the bottom of the frangible ring (68), respectively. If required, lightly tack on gasket (65) to the bottom of the frangible ring (68).

- 2) Install gasket (65), if required.
- 3) Aligning the fastener openings, assemble gasket (66), flange (67), gasket (66), and the frangible ring (68) onto the bladder. Ensure the frangible ring (68) is orientated with the provisions for the fuel cap attachment on the forward side.

## NOTE

To facilitate installation, use one or two longer fasteners to hold the assembly together during installation of the screws.

# ENSTROM TH-28/480 SERIES MAINTENANCE MANUAL

- 4) Install screws (69) (10 places) and torque (50-55 in-lb/5.6-6.2 Nm).
- 5) Install the fuel cap assembly (70) with screws (71) and washers (72) (2 places) and torque (50-55 in-lb/5.6-6.2 Nm).
- 6) Remove the temporary fasteners as required when installing the screws.

- R. Install the air deflector on the top of the cabin.
- S. Install the upper plenum/air inlet (para. 13-31).
- T. Service the fuel cells (para. 4-4) and check for leaks.

## NOTE

Before performing either a fuel quantity system calibration or a low fuel warning test procedure, it is necessary to completely fill the tanks to fully expand the bladder within the fuel cell structure if the bladders are replacements and have not been previously filled with fuel.

- U. Check for proper operation of the fuel quantity system (para. 7-85) and the low fuel warning system (para. 10-41).

## NOTE

Check that gasket (77) is present. It may either be adhered to the fuel cell cover or to the underside of the frangible cover (82).

## NOTE

Apply a light coat of spray adhesive (Super 77 or equivalent) to one side of gasket(s) (81) and (77, if required). Lightly tack on the sprayed side of the gasket(s) to the bottom of the frangible cover (82) to aid installation.

- V. Install gasket (77), if required.

- W. Install gasket (81) and the frangible cover (82) for the fuel quantity transmitter after determining that the system is operating properly. Torque screws (83) to 50-55 in-lb/5.6-6.2 Nm.

- X. Bleed the fuel system I/A/W the Rolls-Royce 250-C20 Series Operation and Maintenance Manual.

# ENSTROM TH-28/480 SERIES MAINTENANCE MANUAL

## C. Overboard vent breakaway valve coupling (25) removal:

### NOTE

Removal procedures are the same for both breakaway couplings unless noted.

- 1) If removing the left-side coupling, disconnect the vent tube (8) from the 90° fitting (29) connected to the roll over valve assembly (30).
- 2) Remove the hose clamps (22), half clamps (23), and O-ring (24) between the coupling (25) and the bladder chimney.
- 3) Disconnect the coupling (25) from the tee fitting (31).
- 4) Remove screws (26), lock washer (46) (1 place), and washers (27) (4 places) that secure the coupling (25) to the bracket.
- 5) Slide the coupling (25) outboard to clear it from the bracket. Pivot the vent chimney down or to the side to facilitate removal of the coupling.

## D. Cross fill breakaway valve coupling (36) removal:

- 1) Disconnect the ground clamp assembly (35) from the coupling bracket assembly (39).
- 2) Remove the hose clamps (32), half clamps (33), and O-ring (34) between the coupling (36) and the cross fill chimneys.
- 3) Remove the frangible ring (37) by removing screws (38) (8 places).
- 4) Slide the coupling (36) outboard to clear it from the bracket (39). Pivot the chimney down or to the side to facilitate removal of the coupling (36).

## E. Fuel line breakaway valve coupling (45) removal:

### NOTE

Removal procedures are the same for both breakaway couplings unless noted.

### CAUTION

When disconnecting fuel lines from the breakaway valve coupling, hold the valve half by the flats to prevent separation of the coupling.

- 1) Disconnect the fuel lines (14) from the forward and aft coupling (45) ends.
- 2) Remove the screws (40), washers (42 and 43), and nuts (44) (4 places) that secure the coupling (45) to the bracket.
- 3) Slide the coupling (45) forward to remove it from the bracket.

# ENSTROM TH-28/480 SERIES MAINTENANCE MANUAL

## 10-18.3 Inspection – CRFS Breakaway Valve Coupling

- A. Inspect the connections for leaks.
- B. Inspect the breakaway valve couplings for security, damage, and indicator dot status.
  - 1) Indicator dots parallel with the valve body indicate the valve is open. Indicator dots perpendicular to the valve body indicate the valve is closed. Refer to Figure 10-3.1. If a valve is closed, replace the breakaway valve coupling.
- C. Inspect the frangible ring (37) for security and damage.
- D. Inspect the ground straps (28 and 41) and ground clamp assembly (35) for security and damage.
  - 1) Check resistance between each breakaway valve coupling test point to the pylon (1 ohm or less). (Refer to Figure 10-3.1 for pictorials of the test point. Refer to Figure 10-2.1, Detail View Q, for the left- and right-side airframe grounding locations.)

## 10-18.4 Repair – CRFS Breakaway Valve Coupling

- A. Repair procedures are not available for the breakaway valve coupling.

## 10-18.5 Installation – CRFS Breakaway Valve Coupling

### CAUTION

Use a backing wrench when installing or removing fluid lines and fittings to prevent damage.

Use care when handling the breakaway valve couplings.

### NOTES

Prior to connecting the overboard vent line and cross fill line, inspect the fuel cell chimneys for restrictions and damage.

Replace all used packing/O-rings.

- A. Cross fill breakaway valve coupling (36) installation:
  - 1) From the right side, install the coupling (36) into the bracket opening. Ensure that the orientation of the coupling is such that the valve indicators are facing up and the test point is facing down. Pivot the right-side chimney down or to the side to facilitate installation of the coupling.
  - 2) Install the frangible ring (37) with screws (38) (8 places). Torque 20 in-lb/2.3 Nm.

# ENSTROM TH-28/480 SERIES MAINTENANCE MANUAL

- 3) Slide a pair of hose clamps (32) over the left- and right-side bladder cross fill chimneys.
- 4) Apply lubricant to new O-rings (34) and install onto each end of the coupling (36).
- 5) Install the coupling (36) to the ends of the cross fill chimneys with a pair of half clamps (33) and secure with the pair of hose clamps (32) (torque 18 in-lb/2.0 Nm). Ensure that the half clamps are evenly seated around the connection and that there is full contact between the inboard half clamp and the coupling for electrical grounding.
- 6) Connect the ground clamp assembly (35) to the coupling bracket assembly (39).

## B. Vent breakaway valve coupling (25) installation:

- 1) Insert the coupling (25) from outboard to inboard into the bracket. Ensure that the final orientation of the coupling is such that the valve indicators and test point are facing up. Pivot the vent chimney down or to the side to facilitate insertion of the coupling into the bracket.
- 2) Install the coupling (25) to the bracket with screws (26), lock washer (46) (1 place), and washers (27) (4 places). Torque 12 in-lb/1.4 Nm.

### NOTE

The lock washer is installed at the single spotface location. (When the coupling is properly installed per step 1), the spotface is at the top, aft location for the left coupling or at the top, forward position for the right coupling.

- 3) Connect the coupling (25) to the tee fitting (31). Torque 230-260 in-lb/26.0-29.4 Nm.
- 4) Slide a pair of hose clamps (22) over the vent chimney.
- 5) Apply lubricant to new O-ring (24) and install.
- 6) Install the coupling (25) to the end of the vent chimney with a pair of half clamps (23) and secure with the pair of hose clamps (22) (torque 18 in-lb/2.0 Nm). Ensure that the half clamps are evenly seated around the connection and that there is full contact between the inboard half clamp and the coupling for electrical grounding.
- 7) If the left-side coupling was installed, connect the vent tube (8) to the 90° fitting (29) connected to the roll over valve assembly (30). Torque 230-260 in-lb/26.0-29.4 Nm.

## C. Fuel line breakaway valve coupling (45) installation:

### NOTE

Installation procedures are the same for both fuel line breakaway couplings unless noted otherwise.

# ENSTROM TH-28/480 SERIES MAINTENANCE MANUAL

- 1) Insert the fuel line breakaway valve coupling (45) from the forward side into the bracket. Ensure that the installation of the coupling is such that the valve indicators and test point are facing outboard.
- 2) Install the coupling (45) to the bracket with screws (40), washers (42 and 43), and nuts (44) (4 places). Torque 7 in-lb/0.8 Nm. Ensure ground strap (41) is installed at the proper attachment point (bare and clean surface).

## CAUTION

When installing fuel lines to the breakaway valve coupling, hold the valve half by the flats to prevent separation of the coupling.

- 3) Connect the fuel lines (14) to the forward and aft coupling (45) ends. Torque 650 in-lb/73.4 Nm.
- D. Service the aircraft (para. 4-4) and check for leaks.
- E. Install the air deflector and upper plenum/air inlet (para. 13-31), if required.
- F. If the aircraft was defueled, bleed the fuel system I/A/W the Rolls-Royce 250-C20 Series Operation and Maintenance Manual.

### 10-18.6 Roll Over Valve Assembly

### 10-18.7 Removal – Roll Over Valve Assembly

## NOTE

Cover all open ports and lines to prevent contamination of the fuel system.

## CAUTION

Use a backing wrench when installing or removing fittings to prevent damage.

- A. Remove the upper plenum/air inlet (para. 13-28) and air deflector.
- B. Disconnect the vent tube (8) from the 90° fitting (29) connected to the roll over valve assembly (30).
- C. Disconnect the 90° fitting (29) connected to the roll over valve assembly (30).
- D. Disconnect the roll over valve assembly (30) from the tee fitting (31).

### 10-18.8 Inspection – Roll Over Valve Assembly

- A. Inspect the roll over valve assembly for security and damage.
- B. Inspect the roll over valve assembly for open condition.

# ENSTROM TH-28/480 SERIES MAINTENANCE MANUAL

- 1) With the roll over valve assembly positioned upright, check for the feel the internal ball movements while shaking the roll over valve. Also, blow clean air down through the top opening (maximum 1 psi). If ball movements are felt and exiting air can be felt at the base of the assembly, the valve is open. If no movement of the ball is felt and exiting air cannot be felt at the base of the assembly, the valve is closed.
- 2) If the valve is closed, replace the roll over valve assembly.

## 10-18.9 Repair – Roll Over Valve Assembly

- A. Repair procedures are not available for the roll over valve assembly.

## 10-18.10 Installation – Roll Over Valve Assembly

- A. Install the roll over valve assembly (30) to the tee fitting (31). Torque 330-360 in-lb/37.3-40.7 Nm.
- B. Install the 90° fitting (29) to the roll over valve assembly (30). Torque 460-500 in-lb/52.0-56.5 Nm.
- C. Connect the vent tube (8) to the elbow fitting (29). Torque 230-260 in-lb/26.0-29.4 Nm.
- D. Install the air deflector and upper plenum/air inlet (para. 13-31).

## 10-19. Sump Drain Valves

### 10-20. Removal – Sump Drain Valves

- A. Defuel the aircraft (para. 4-5).

#### CAUTION

Use a backing wrench when installing or removing fluid lines and fittings to prevent damage.

- B. Disconnect the drain lines from the valves.
- C. Remove the valves.

### 10-21. Inspection – Sump Drain Valves

- A. Inspect the valves for damage, leaks, and proper operation.

### 10-22. Repair – Sump Drain Valves

- A. Replace valves that leak or fail to operate properly after resealing the threads for leaks around the threads or flushing the valve to attempt to remove possible debris from a sticky or leaking valve.

# ENSTROM TH-28/480 SERIES MAINTENANCE MANUAL

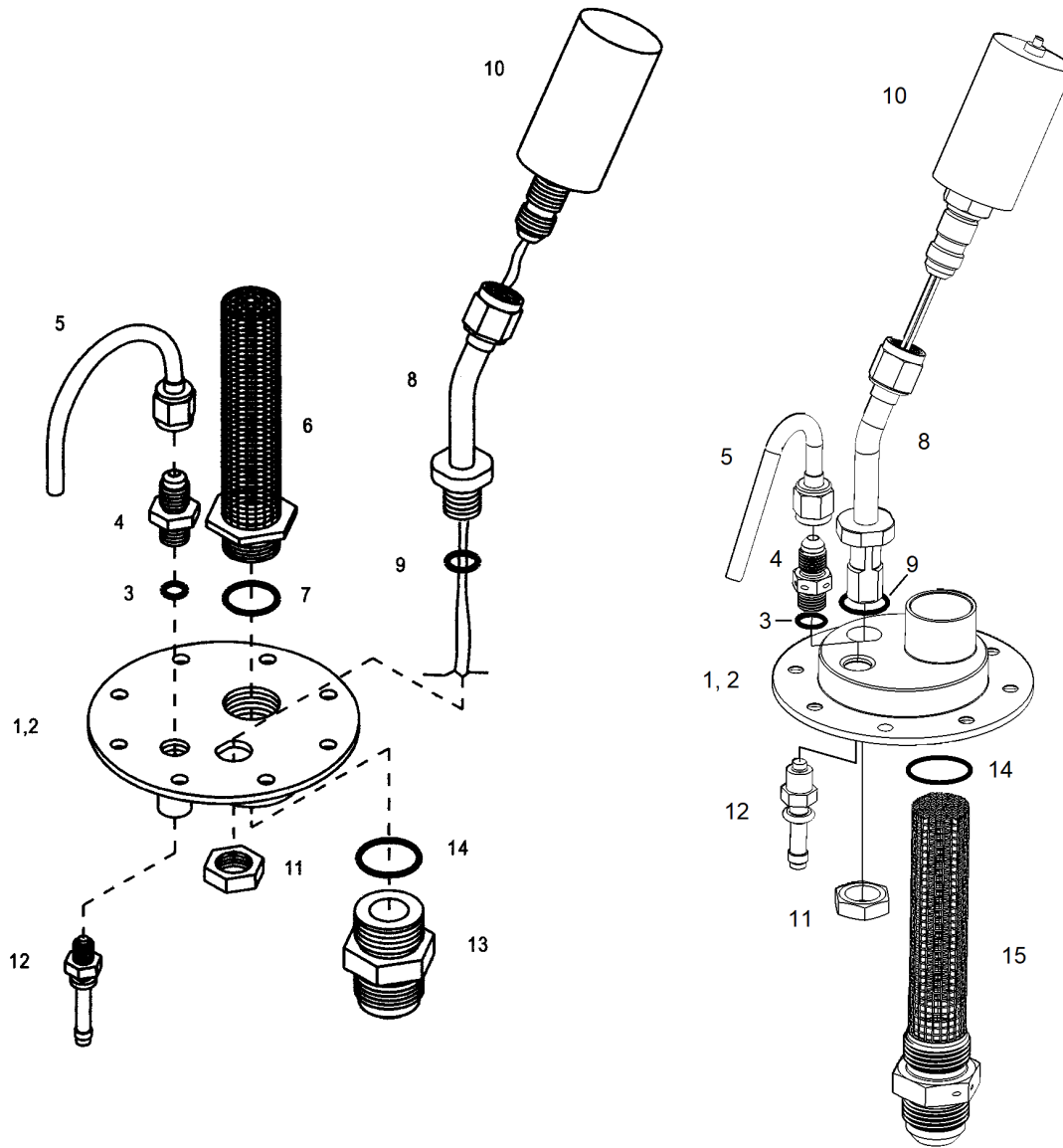

Standard System

*(Right-side sump assembly shown)*

CRFS

- |    |                                  |     |                            |
|----|----------------------------------|-----|----------------------------|
| 1. | Flange Plate (Left Side)         | 9.  | O-Ring (R/S Only)          |
| 2. | Flange Plate (Right Side)        | 10. | Low Fuel Switch (R/S Only) |
| 3. | O-Ring                           | 11. | Nut                        |
| 4. | Sump Fitting                     | 12. | Sump Drain Valve           |
| 5. | Syphon Tube Assembly             | 13. | Fitting                    |
| 6. | Fuel Strainer Assembly           | 14. | O-Ring                     |
| 7. | O-Ring                           | 15. | Fuel Strainer Assembly     |
| 8. | Support Tube Assembly (R/S Only) |     |                            |

Figure 10-4. Sump Assembly

# ENSTROM TH-28/480 SERIES MAINTENANCE MANUAL

## 10-51.3 Installation – Fuel Quantity Probe, Aerazur Fuel Bladder System

### NOTE

The following procedure is applicable to TH-28 S/N 3006 and previous, and 480 S/N 5012 and previous. See also Figure 10-1.

A. If removed, install the low fuel warning switch and bracket on the fuel quantity probe (para. 10-46).

### NOTE

The low fuel warning switch must be orientated toward the front of the aircraft.

B. Install the fuel quantity probe into the fuel cell, place the bottom adapter into the cup on the bottom of the fuel cell, and secure in position with the retaining clamp.

C. Install the electrical connectors for the fuel quantity probe and low fuel warning switch onto the mounting plate in the fuel cell. Ensure they are properly installed or they will leak.

D. Install the upper portion of the fuel quantity probe in the upper cup of the fuel cell and secure with the retaining clamp.

E. Install the fuel cell access plates (zipper) and torque the hardware to 40-50 in-lbs/4.5-5.7 Nm.

F. Reinstall the lacing cord and secure the upper portion of the fuel cell to the support structure.

G. Connect the electrical leads for the fuel quantity probe and low fuel warning switch.

H. Connect the overboard vent crossover (para. 10-18).

I. Install the fuel cell cover (para. 8-17).

J. Install the air deflector and the upper plenum/air inlet (para. 13-31).

K. Check the calibration of the fuel quantity system (para. 7-85) if the fuel quantity probe was replaced or the system is suspected of being out of calibration.

L. Perform a functional test of the low fuel warning system (para. 10-41), adjust as required.

M. Perform a leak check while servicing the aircraft.

N. Bleed the fuel system I/A/W the Rolls-Royce 250-C20 Series Operation and Maintenance Manual.

# ENSTROM TH-28/480 SERIES MAINTENANCE MANUAL

## 10-51.4 Installation – Fuel Quantity Transmitter, CRFS

### NOTE

Aircraft S/N 5256 and subsequent are configured with P/N ECD4092-3 fuel quantity transmitter at the time of manufacture. See also Figure 10-2.1.

- A. Install a new O-ring (78) in the base of the flanged cup assembly (74).
- B. Install the fuel quantity transmitter (79) into the fuel bladder:
  - 1) Ensure the alignment of the three locating holes on the base of the transmitter with the three alignment pins in the flanged cup assembly (74).
  - 2) Orientate the end of the transmitter toward the lower corner of the fuel cell and into the rubber cup.

### NOTE

The spanner nut (80) may be used as a tool to install the transmitter. Install the slotted side over the notches of the transmitter and engage the slots in the groove around the perimeter of the transmitter. Push the nut to seat the transmitter in the base of the flanged cup assembly to ensure even compression with the O-ring prior to torquing. Remove the nut and flip over for installation.

- C. Install the spanner nut (80). Torque 120 in-lb/13.6 Nm.
- D. Connect the electrical wiring for the fuel quantity transmitter.
  - 1) Check resistance between transmitter grounding strap and aircraft structure to be less than or equal to 10 milliohms.
  - 2) Apply a corrosion inhibitor (para. 10-59) to the ground wire and the transmitter wire connections.
- E. Safety (0.032") the spanner nut (80) to one flanged cup assembly attachment bolt.
- F. Service the fuel cells (para. 4-4) and check for leaks.
- G. Check the calibration of the fuel quantity system (para. 7-85) if the fuel quantity transmitter was replaced or the system is suspected of being out of calibration.

### NOTE

Check that gasket (77) is present. It may either be adhered to the fuel cell cover or to the underside of the frangible cover (82).

### NOTE

Apply a light coat of spray adhesive (Super 77 or equivalent) to one side of gasket(s) (81) and (77, if required). Lightly tack on the sprayed side of the gasket(s) to the bottom of the frangible cover (82) to aid installation.

# ENSTROM TH-28/480 SERIES MAINTENANCE MANUAL

- H. Install gasket (77), if required.
- I. Install gasket (81) and install fuel quantity transmitter frangible cover (82) with screws (83) (6 places). Torque 50-55 in-lb/5.6-6.2 Nm.
- J. Bleed the fuel system I/A/W the Rolls-Royce 250-C20 Series Operation and Maintenance Manual.

## 10-52. External Fuel Filter (Optional Equipment)

### NOTE

The external fuel filter is an equipment option for the legacy fuel systems only.

## 10-53. Description – External Fuel Filter

An optional external fuel filter can be installed on the TH-28 (S/N 3007 and subsequent) and the 480/B (S/N 5003 and subsequent). The filter assembly, located on the left side of the pylon near the lateral trim motor assembly, is installed between the fuel shutoff valve and the engine fuel inlet. The filter assembly incorporates a drain in the bottom of the bowl assembly, a bypass valve, an impending bypass indicator which is an electrical switch that is connected to the caution panel, and a test button for checking the operation of the electrical switch. The filter element is replaced every 300 hours or when the impending bypass indicator activates.

## 10-54. Filter Element Replacement – External Fuel Filter

- A. Pull the fuel shutoff valve to OFF.
- B. Disconnect the battery.
- C. Place a suitable container beneath the filter assembly drain and drain the fuel from the filter assembly and the fuel lines.
- D. Remove the lockwire securing the bowl assembly and remove the bowl assembly from the filter assembly.
- E. Discard the filter element, the bowl assembly O-ring, and the filter element seals.
- F. Install new filter element seals, a new bowl assembly O-ring, and a new filter element.
- G. Install the bowl assembly onto the filter assembly and torque to 100-150 in-lb/11.7-17.0 Nm. Lockwire the bowl assembly to the filter assembly.
- H. Open the fuel shutoff valve.
- I. Connect the battery.
- J. Bleed the fuel system I/A/W the Rolls-Royce 250-C20 Operation and Maintenance Manual.

# ENSTROM TH-28/480 SERIES MAINTENANCE MANUAL

## 10-55. Removal – External Filter Assembly

- A. Pull the fuel shutoff valve to OFF.
- B. Disconnect the battery.
- C. Place a suitable container beneath the filter assembly drain and drain the fuel from the filter assembly and the fuel lines.
- D. Disconnect the electrical connector from the filter assembly.
- E. Disconnect the fuel lines from the inlet and outlet ports of the filter assembly.
- F. Remove the hardware securing the filter assembly mounting bracket to the pylon and remove the filter assembly from the aircraft.
- G. Remove the hardware securing the filter assembly to the mounting bracket and remove the filter assembly from the mounting bracket.

## 10-56. Inspection – External Filter Assembly

- A. Inspect the filter assembly for damage, leaks, and security of installation.
- B. Inspect the mounting bracket for cracks, bends, corrosion, and security of installation.
- C. Inspect the electrical connector and wiring for general condition.
- D. Operate the test button and check for proper operation of the impending bypass switch.

## 10-57. Repair – External Filter Assembly

- A. Replace the filter assembly if damage causes the assembly to be unserviceable.
- B. Repair the mounting bracket I/A/W AC 43.13-1B. Replace damaged or missing hardware.
- C. Repair or replace the electrical connector or wiring if damaged.
- D. Replace the filter assembly if the impending bypass switch does not function properly.

## 10-58. Installation – External Filter Assembly

- A. Install the filter assembly onto the mounting bracket.
- B. Position the filter assembly onto the pylon and install the securing hardware.
- C. Connect the fuel lines to the inlet and outlet ports.

# ENSTROM TH-28/480 SERIES MAINTENANCE MANUAL

G. Heat the sleeve to approximately 250°F/121°C. Install the sleeve onto the lower pulley driven shaft and seat against the bearing retainer.

H. Install the pulley adapter (Figure 11-5) the lower pulley driven shaft and place the pulley assembly vertically in a vise.

I. Install the retaining nut and torque to 190-200 ft-lb/259.1-272.7 Nm using tool T-0051. Allow the pulley assembly to cool and retorque the retaining nut. Install two safeties (.032 lockwire) between the lower pulley bearing retaining nut and the pulley drive shaft. Secure the wire tails under the wire wrap.

J. Install the grease fittings and vents in the grease lubricated bearing housings. Install the drain plugs and sight plugs in the oil lubricated bearing housings. Torque the sight plugs to 150 in-lb/17 Nm and install a torque slippage mark.

K. Using a standard grease gun, lubricate the grease lubricated bearing assemblies with 6-8 pumps/squirts of grease (MIL-PRF-81322). Refer to paragraph 4-33 for lubrication procedures to use during normal scheduled servicing. Service each oil lubricated bearing assembly with 0.27 U.S. ounces/8 ml of oil (MIL-PRF-23699). Install the service plugs. Refer to paragraph 4-24 for servicing procedures to use during normal scheduled servicing.

L. Remove the pulley assembly from the vise and remove the pulley adapter.

## NOTE

Ensure the spacers are installed with the beveled face toward the flex pack coupling.

## NOTE

Place the thick spacers between the flex pack coupling and the lower pulley and lower pulley drive shaft hub flanges.

M. Install the aft flex pack coupling on the pulley drive shaft hub.

## CAUTION

Ensure the hardware in the aft flex pack coupling does not contact the lower pulley bearing housing.

N. Attach the aft flex pack coupling/drive shaft hub to the lower pulley driven shaft.

O. Install the lower pulley adapter on the lower pulley drive shaft and place the shaft vertically in a vise.

P. Apply a light coat of grease (MIL-PRF-81322) to the splines of the lower pulley drive shaft. Place the lower pulley assembly on the lower pulley drive shaft. Install the drive shaft hub onto the splines of the lower pulley drive shaft. Install the washer (P/N C148740) and retaining nut and torque to 90-100 ft-lb/122.0-135.6 Nm. Safety wire (MS20995C32) the retaining nut to the tapered pin. To prevent snagging and/or unraveling, allow sufficient tail length such that the tail can be secured to the installed safety wire and wrapped around the safety wire at least twice.

# ENSTROM TH-28/480 SERIES MAINTENANCE MANUAL

Q. Install the intermediate oil cooler blower drive shaft hub on the lower pulley drive shaft and install the roll pins/taper pin. Install the oil cooler blower drive shaft hub wet with epoxy primer. If installing new roll pins, it is permissible to trim the roll pins after they are installed. Install a safety (.032 lockwire) from the retaining nut to the roll pins/taper pin.

## NOTE

If components of the lower pulley assembly have been replaced, the thickness of the spacers used on the forward flex pack coupling may have to be changed.

- R. Install the forward flex pack coupling on the lower pulley drive shaft.
- S. Install the "H"- strut onto the lower pulley bearing housings.
- T. Install the bearing temperature thermocouples into the bearing housings.

## 11-24. Installation – Lower Pulley Assembly (Figure 11-2)

- A. Install the positioning links onto their fittings.
- B. Install the lower pulley assembly into the drive belt.
- C. Rotate the pulley so the "H"- strut is toward the left side of the aircraft. Install the load bearing plugs (older "H"-strut assemblies) and the flat bearing (DU side up) into the "H"- strut and install the tensioning assemblies onto the "H"- strut.
- D. Rotate the "H"- strut into position and attach the tensioning assemblies to the main rotor transmission and the aft pinion bearing support truss.
- E. Align the lower pulley drive system (para.11-17).

## NOTE

Ensure the spacers are installed with the beveled face toward the flex pack coupling.

## NOTE

If components of the lower pulley assembly have been replaced, the thickness of the spacers used on the forward flex pack coupling may have to be changed.

## CAUTION

The bolts connecting the forward flex pack to the power output shaft are special bolts that have shortened thread grip lengths. Do not replace with standard hardware.