

**ENSTROM 480B OPERATOR'S MANUAL
AND
FAA APPROVED
ROTORCRAFT FLIGHT MANUAL
EASA SUPPLEMENT**

GMA 350H AUDIO PANEL

* * * * *

REPORT NO. 28-AC-073

HELICOPTER SERIAL NO. _____

HELICOPTER REGISTRATION NO. _____

* * * * *

**THIS SUPPLEMENT MUST BE CARRIED IN THE
HELICOPTER AT ALL TIMES IF EQUIPPED WITH THE
GMA 350H INSTALLATION.**

**CHAPTERS 1, 2, 3, AND 4 ARE FAA APPROVED ON
BEHALF OF EASA.**

FAA APPROVED BY: 
SM: TIMOTHY P. SMYTH, MANAGER
CHICAGO AIRCRAFT CERTIFICATION OFFICE
CENTRAL REGION
FEDERAL AVIATION ADMINISTRATION

FAA APPROVAL DATE: MAY 11 2017

PROPRIETARY

The information contained herein is proprietary to The Enstrom Helicopter Corporation and shall not be reproduced or disclosed in whole or in part for any PURPOSE except when such user possesses direct, written authorization from Enstrom Helicopter Corporation

THE ENSTROM HELICOPTER CORPORATION
2209 22ND STREET
MENOMINEE, MICHIGAN 49858-0490

INTENTIONALLY LEFT BLANK

LOG OF REVISIONS

Rev. No.	Date	FAA Approval on Behalf of EASA
-	MAY 11 2017	 ACE-117C

APPROVED FOR THE MANAGER
CHICAGO AIRCRAFT CERTIFICATION OFFICE
CENTRAL REGION
FEDERAL AVIATION ADMINISTRATION

INTENTIONALLY LEFT BLANK

ROTORCRAFT FLIGHT MANUAL EASA SUPPLEMENT
GARMIN GMA 350H AUDIO PANEL

TABLE OF CONTENTS

<u>CHAPTER</u>	<u>DESCRIPTION</u>	<u>PAGE</u>
	Supplement Cover Page	
	Log of Revisions	i
	Table of Contents.....	iii
	List of Figures.....	iv
	List of Tables	iv
	List of Effective Pages	v
	INTRODUCTION	INTRO-1
CHAPTER 1	OPERATING LIMITATIONS	
1-1	General	1-1
1-2	Operational Limits	1-1
CHAPTER 2	NORMAL PROCEDURES	
2-1	General	2-1
CHAPTER 3	EMERGENCY PROCEDURES	
3-1	General	3-1
CHAPTER 4	PERFORMANCE DATA	
4-1	General	4-1
CHAPTER 5	RESERVED	
CHAPTER 6	WEIGHT/BALANCE AND LOADING	
6-1	General	6-1
CHAPTER 7	SYSTEM DESCRIPTION AND OPERATION	
7-1	System Description.....	7-1
7-2	General Operation	7-3
7-3	Power-Up.....	7-3
7-4	Controls	7-4
7-5	Transceivers	7-4
7-6	Receivers	7-5
7-7	Marker Beacon Receiver	7-5
7-8	Intercom System.....	7-5

ROTORCRAFT FLIGHT MANUAL EASA SUPPLEMENT
GARMIN GMA 350H AUDIO PANEL

CHAPTER 7	SYSTEM DESCRIPTION AND OPERATION	
7-9	Volume Adjustment.....	7-5
7-10	Entertainment Inputs.....	7-6
7-11	Entertainment Audio.....	7-7
7-12	Recorder.....	7-7
7-13	Voice Recognition.....	7-7
7-14	3D Audio.....	7-7

LIST OF FIGURES

<u>FIGURE</u>	<u>DESCRIPTION</u>	<u>PAGE</u>
7-1	GMA 350H Installation.....	7-2
7-2	GMA 350H System Block Diagram.....	7-3
7-3	GMA 350H Controls.....	7-4

LIST OF TABLES

<u>TABLE</u>	<u>DESCRIPTION</u>	<u>PAGE</u>
Intro-1	List of Abbreviations.....	INTRO-1
7-1	GMA 350H Controls.....	7-8

LIST OF EFFECTIVE PAGES

<u>PAGE</u>	<u>DATE</u>	<u>PAGE</u>	<u>DATE</u>
i	May 3/17		
ii	May 3/17		
iii	May 3/17		
iv	May 3/17		
v	May 3/17		
vi	May 3/17		
INTRO-1	May 3/17		
INTRO-2	May 3/17		
1-1	May 3/17		
1-2	May 3/17		
2-1	May 3/17		
2-2	May 3/17		
3-1	May 3/17		
3-2	May 3/17		
4-1	May 3/17		
4-2	May 3/17		
6-1	May 3/17		
6-2	May 3/17		
7-1	May 3/17		
7-2	May 3/17		
7-3	May 3/17		
7-4	May 3/17		
7-5	May 3/17		
7-6	May 3/17		
7-7	May 3/17		
7-8	May 3/17		

INTENTIONALLY LEFT BLANK

INTRODUCTION

Intro-1. General

This supplement contains the operating instructions, procedures, and limitations for helicopters equipped with the Garmin GMA 350H Audio Panel Installation and registered in countries that recognize approvals granted by EASA.

The supplement is divided into two basic parts, the FAA Approved (on behalf of EASA) RFM Supplement (Chapters 1, 2, 3, and 4) and Supplemental Data provided by the Enstrom Helicopter Corporation (Enstrom). It is required by EASA Regulations that this supplement be carried in the helicopter at all times if the GMA 350H is installed.

In this document, the term *GMA 350H* may be used interchangeably in reference to the complete GMA 350H system or in reference to the audio panel unit.

For additional information regarding the supplement format and text emphasis or definitions, refer to the Basic Flight Manual. Abbreviations noted in this supplement are listed in Table Intro-1.

Table Intro-1. List of Abbreviations

ARM	ARM Holdings (processor manufacturer)
AUX	Auxiliary
CRSR	Cursor
COM	Communication
DSP	Digital Signal Processor
EASA	European Aviation Safety Agency
FAA	Federal Aviation Administration
GPS	Global Positioning System
ICS	Intercom System
MAN	Manual
MKR	Marker

Table Intro-1. List of Abbreviations

MIC	Microphone
MUS	Music
NAV	Navigation
PA	Public Announcement
PASS	Passenger
PTT	Press to Talk
RFM	Rotorcraft Flight Manual
SPKR	Speaker
SQ	Squelch
VOL	Volume

CHAPTER 1. OPERATING LIMITATIONS

1-1. General

1. This chapter includes operating limitations and restrictions that must be observed during ground and flight operations.

2. The operating limitations set forth in this chapter are the direct results of design analysis and flight tests. Compliance with these limitations will allow the pilot to derive maximum utility from the helicopter.

3. Use of this rotorcraft flight manual supplement is limited to GMA 350H-equipped helicopters registered in countries that recognize approvals granted by EASA.

1-2. Operational Limits

1. The GMA 350H must utilize the software versions as follows:

GMA 350H Processor	Software Version*
DSP	3.05
AUX (ARM)	2.21
*or later FAA Approved version	

2. The GMA 350H Pilot's Guide, Document Number 190-01134-14, Revision C or later revision, should be referred to for operating instructions and must be kept accessible to the flight crew at all times.

3. Voice recognition operation not authorized (reference paragraph 7-13).

INTENTIONALLY LEFT BLANK

CHAPTER 2. NORMAL PROCEDURES

2-1. General

Refer to the basic RFM.

INTENTIONALLY LEFT BLANK

CHAPTER 3. EMERGENCY PROCEDURES

3-1. General

If there is a failure of the GMA 350H or when power is not applied, a fail-safe circuit connects the pilot's headset and microphone directly to the COM1 transceiver.

INTENTIONALLY LEFT BLANK

CHAPTER 4. PERFORMANCE DATA

4-1. General

Refer to the basic RFM.

INTENTIONALLY LEFT BLANK

CHAPTER 6. WEIGHT/BALANCE AND LOADING

6-1. General

This installation is included in the basic aircraft weight. Refer to the basic RFM.

INTENTIONALLY LEFT BLANK

CHAPTER 7. SYSTEM DESCRIPTION AND OPERATION

7-1. System Description

1. The GMA 350H audio panel provides audio selector functions of microphone and receiver audio selection. The audio panel includes ICS, night vision compatible green annunciation and backlighting, a front panel entertainment/telephone jack, and an optional marker beacon receiver. The GMA 350H also features 3D audio capability.

- a. The Voice Recognition feature is not enabled for this installation.

2. The components of the GMA 350H installation include the GMA 350H audio panel unit located in the avionics panel, and an entertainment jack located on the lower copilot side of the pedestal, and the marker beacon sensitivity toggle switch located on the lower right side of the circuit breaker panel and marker beacon antenna (if configured). The GMA 350H installation does not include an external speaker/PA system.

3. The GMA 350H may be configured with traditional avionic component systems (such as VOR/LOC/GS, GPS, NAV/COM, transponder, etc.) or with the Garmin G1000H Integrated Flight Deck. The system block diagram is shown in Figure 7-2.

4. Power to the GMA 350H system is provided via the battery switch (**BATT**). Power to the GMA 350H audio panel is provided via the **AUDIO PANEL** circuit breaker (2 amp, G1000H configuration; 5 amp, standard configuration) located on the left side of the lower panel (Figure 7-1).

5. The marker beacon receiver (if configured) detects three marker beacon signals (outer, middle, and inner). The corresponding marker beacon tone is heard. The signal sensitivity can be set with the **MKR SENS** toggle switch (Figure 1). The GMA 350H does not have a discrete marker beacon display. Depending on the aircraft configuration, it may be displayed on other avionic equipment.

6. Refer to the GMA 350H Pilot's Guide for additional information on the features of the GMA 350H (para. 1-2).

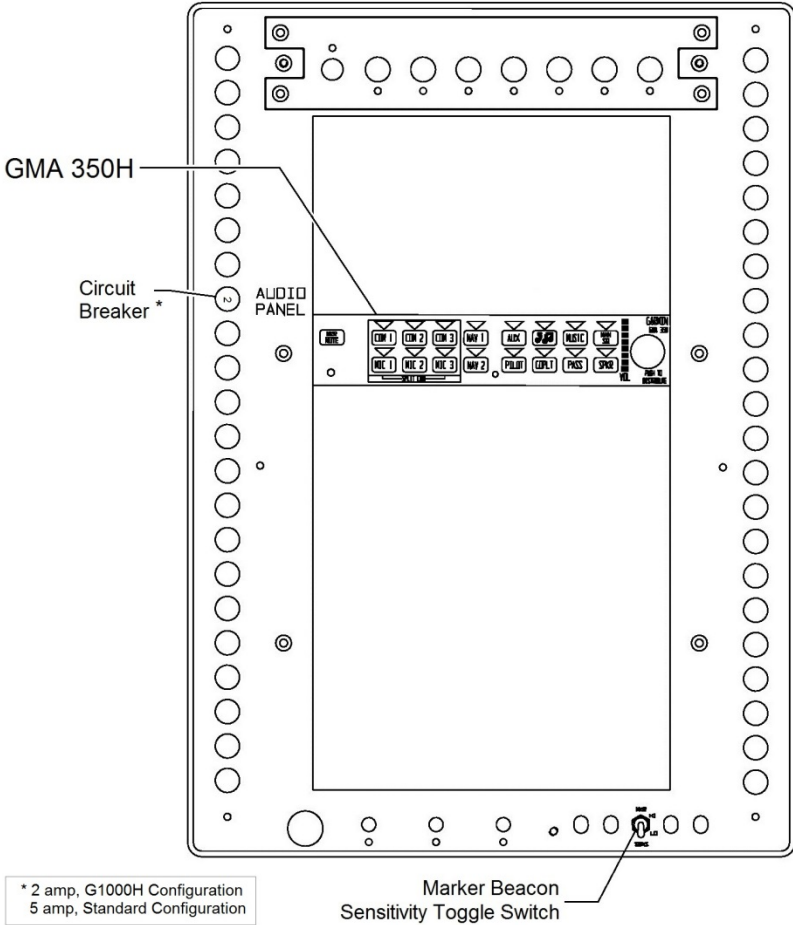

Figure 7-1. GMA 350H Installation Configured with Marker Beacon Receiver

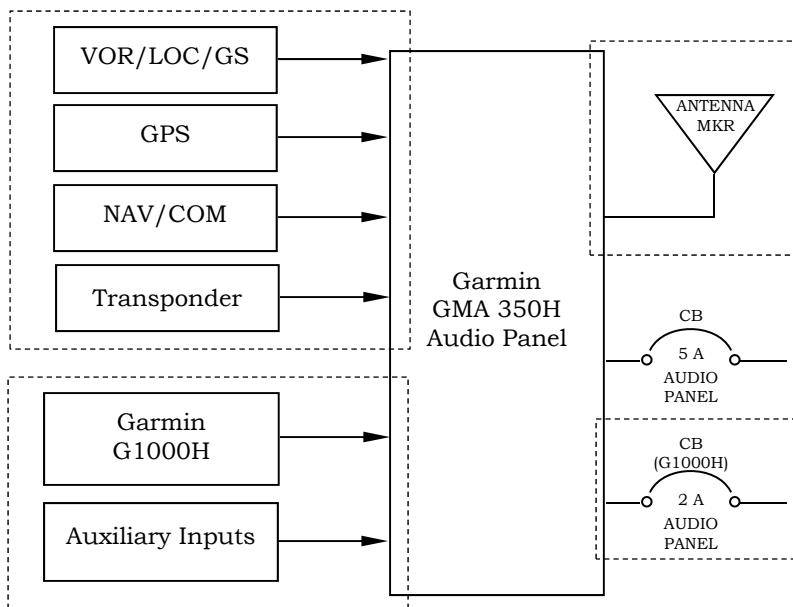

Figure 7-2. GMA 350H System Block Diagram (system options indicated with dashed outline)

7-2. General Operation

The following content covers basic operational procedures. Refer to the GMA 350H Pilot's Guide for operational procedures regarding the COM audio recorder, and 3D audio operation (para. 1-2).

7-3. Power-Up

1. The GMA 350H is powered on when the battery switch (**BATT**) is turned on.
2. The GMA 350H performs a self-test during power-up. All audio panel annunciator lights will illuminate for approximately two seconds during the self-test.
3. After a complete self-test, most of the settings are restored to those in use before the unit was last turned off.

7-4. Controls

The audio panel controls are shown in Figure 7-3. The functions of the audio panel controls are summarized in Table 7-1.

When a key is selected, the annunciator above the key is illuminated.



Figure 7-3. GMA 350H Controls

7-5. Transceivers

1. Press the **COM1**, **COM2**, or **COM3** key to select audio from the respective COM receiver.

2. Press the **MIC1**, **MIC2**, or **MIC3** key to transmit from the respective transmitter. The related COM receiver is simultaneously selected. The other COM receiver(s) can be added by pressing the respective key(s). During COM transmission, the active transceiver key annunciator flashes.

3. Select a second **MIC** key to transmit over separate radios (Split-COM operation). During Split-COM operation, the pilot transmits on the lower-numbered COM and the copilot transmits on the higher-numbered COM. Also, during Split-COM transmission, the respective **MIC** annunciator flashes when the PTT is pressed. Press one of the **MIC** keys to cancel Split-COM operation.

4. Press and hold **COM1** or **COM2** to enable/disable monitored COM muting during reception of audio from the COM radio selected for transmission. The aural message **“Mute Monitored COM on Primary COM Reception Enabled/Disabled”** is heard.

7-6. Receivers

1. Press the **NAV1** and/or **NAV2** keys to select audio for the respective navigation radio source.

7-7. Marker Beacon Receiver (If Configured)

1. Press the **MKR/MUTE** key to activate marker beacon audio. The **MKR/MUTE** annunciator will illuminate during reception. Press the **MKR/MUTE** key twice to deactivate marker beacon audio.

2. During marker beacon audio reception, press the **MKR/MUTE** key to mute the audio. The **MKR/MUTE** annunciator remains lit, but the current marker tone is silenced. Audio muting deactivates automatically and marker beacon audio is heard when the next marker beacon signal is received.

3. Toggle the **MKR SENS** to **HI** or **LO** to select the desired audio sensitivity.

7-8. Intercom System

1. Press the **PILOT**, **COPLT**, and/or **PASS** keys to distribute audio as required. The associated annunciators illuminate indicating shared intercom audio.

- a. If an annunciator is not lit, that position is isolated from the others. Refer to the GMA 350H Pilot's Guide for selecting various isolate configurations.

7-9. Volume Adjustment

Turning the outer **CRSR** control knob activates and moves the cursor (flashing green annunciator) to select the audio source for volume adjustment. Turning the inner **VOL** control knob adjusts the volume or manual squelch for the selected audio source.

The cursor will cancel after a few seconds if there is no input and default to the **PILOT** key. Likewise, pressing the **VOL** knob while the cursor is flashing cancels the cursor. If the **VOL** knob is pressed twice, Blue-Select

Mode will be activated. Press the **VOL** knob again to cancel Blue-Select Mode. Blue-Select Mode is explained in paragraph 7-11.

Volume adjustment for the audio functions is as follows:

1. Intercom Volume

- a. Turn the **CRSR** knob to activate and/or move the cursor over **PILOT**, **COPLT**, or **PASS**. Turn the **VOL** knob to adjust the intercom volume for the listener.

2. Manual Squelch

- a. Turn the **CRSR** knob to activate and/or move the cursor over **MAN SQ**. Turn the **VOL** knob to adjust the ICS squelch threshold.

3. Marker Beacon, Music, and Aux Volume

- a. Turn the **CRSR** knob to activate and/or move the cursor over **MKR**, **AUX**, , or **MUSIC**. Turn the **VOL** knob to adjust the volume of the selected source.

7-10. Entertainment Inputs

1. Press the  key to enable audio from a telephone or entertainment device connected to the front panel jack or one of the jacks on the copilot side pedestal.

2. Press the **MUSIC** key to toggle entertainment audio.

3. Audio distribution of the entertainment inputs using Blue-Select Mode is discussed in paragraph 7-11.

4. Telephone and entertainment audio is always muted during alerts. At any other time, muting can be enabled or disabled by pressing and holding the **MUSIC** or  key for two seconds. The aural message **“Mute Music on Reception Enabled/Disabled”** or **“Mute Tel and Jack on Reception Enabled/Disabled”** is heard.

7-11. Entertainment Audio

Entertainment (music or telephone) audio is distributed independently to crew and passengers by using Blue-Select Mode.

1. Press the **VOL** knob to enter Blue-Select Mode when the cursor is not flashing. The annunciator over the  key will be flashing blue. The Blue-Select Mode will automatically cancel after 10 seconds if no input is received.

- a. Turn the **CRSR** knob to select **MUSIC**.
- b. Select the desired key(s) (**PILOT**, **COPLT**, and/or **PASS**) to turn the blue annunciator on or off to distribute audio to selected crew/passenger positions.
- c. Pressing the **VOL** knob will cancel Blue-Select Mode or selecting any key other than **PILOT**, **COPLT**, **PASS**, **MUSIC**, or  will also cancel Blue-Select Mode.

7-12. Recorder

The GMA 350H contains a digital clearance recorder that records up to 2.5 minutes of the selected COM radio signal. Refer to the GMA 350H Pilot's Guide for recorder operation.

7-13. Voice Recognition

The GMA 350H Voice Recognition feature is not enabled for this installation.

7-14. 3D Audio

The GMA 350H features 3D Audio processing that is useful when multiple audio sources are present. Refer to the GMA 350H Pilot's Guide for 3D Audio operation.

Table 7-1. GMA 350H Controls

1	MRK MUTE	1. Selects the marker beacon receiver audio 2. Mutes the marker beacon receiver audio
2	COM1	1. Selects audio from #1 COM receiver 2. Press and hold to enable/disable monitored COM muting
3	COM2	1. Selects audio from #2 COM receiver 2. Press and hold to enable/disable monitored COM muting
4	COM3	1. Selects audio from #3 COM receiver 2. Press and hold to enable/disable monitored COM muting
5	NAV1	Selects audio from #1 NAV receiver
6	AUX	Selects audio from AUX inputs
7		1. Selects/deselects audio from the front panel or copilot side pedestal jacks 2. Press and hold to enable/disable muting
8	MUSIC	1. Selects/deselects entertainment audio 2. Press and hold to enable/disable muting
9	MAN SQ	Select/deselect manual squelch
10	--	Indicates volume/squelch setting
11	--	Front panel entertainment/telephone jack
12	MIC1	Selects #1 transmitter (COM1 receive)
13	MIC2	Selects #2 transmitter (COM2 receive)
14	MIC3	Selects #3 transmitter (COM3 receive)
15	NAV2	Selects audio from #2 NAV receiver
16	PILOT	Controls the pilot ICS
17	COPLT	Controls the copilot ICS
18	PASS	Controls the passenger ICS
19	SPKR	(Not available)
20	CRSR	Activates and/or moves cursor (turn knob)
21	VOL	1. Adjusts volume (turn knob) 2. Activates/cancels Blue-Select Mode (press knob)