



# SERVICE INFORMATION LETTER

---

SERVICE INFORMATION LETTER NO. 0146

Page 1 of 6

DATE: October 3, 1997

1. SUBJECT: Improved Main Rotor Control Rod Assembly
2. MODELS: F-28A, 280, F-28C, and 280C
3. EFFECTIVITY: All Serial Numbers
4. BACKGROUND:

Enstrom changed the design of the end fitting installed in the main rotor control rod assembly. This change is standard on F-28F, 280F, and 280FX model helicopters and improves the reliability and service life of the control rod assembly. This Service Information Letter authorizes installation of the improved control rod assembly and the associated parts on F-28A, 280, F-28C, and 280C model helicopters.

5. COMPLIANCE:

At owner/operator option, the main rotor control rod assemblies, P/N 28-16253-1, may be either modified in accordance with paragraph 5.1 or replaced with improved main rotor control rod assemblies, P/N 28-16253-101, in accordance with paragraph 5.2.

## NOTE

Modification of the control rod assemblies or installation of P/N 28-16253-101 control rod assemblies requires installation of P/N 28-14207-7 or 28-14207-101 pitch change bellcranks (cyclic walking beams). All main rotor control rod assemblies installed in the helicopter must have the same configuration.

- 5.1. MODIFICATION:

## NOTE

Perform all maintenance procedures in accordance with the applicable aircraft maintenance manual.

1. Remove the main rotor pitch change bellcranks, P/N 28-14207-1.
2. Remove the main rotor control rod assemblies, P/N 28-16253-1.
3. Index mark the location of the end fitting in the control rod (See Figure 1).
4. Remove the rivets securing the end fitting in the control rod and remove the end fitting (See Figure 1).
5. Using a suitable light source, visually inspect the inside surface of the control rod for corrosion. If light surface corrosion is found, hone the inside surface to remove the corrosion and coat the inside surface with epoxy primer. If corrosion other than light surface corrosion is found, the control rod assembly must be replaced.
6. Using a suitable press, install the bearing, P/N MS21240-08-C-12, into the new end fitting, P/N 28-16253-15 (See Figure 2).
7. Transfer the index mark from the old end fitting to the new fitting and temporarily install the fitting in the control rod (See Figure 3).
8. Using the existing rivet holes in the control tube, drill holes in the new fitting using a #27 drill bit. Use clecos to maintain rivet hole alignment.
9. Remove the end fitting from the control rod and remove the drill chips from the control rod.
10. Apply epoxy primer to the mating surfaces of the end fitting and the control rod and install the end fitting in the control rod while the epoxy primer is wet. Secure the end fitting using four (4) rivets, P/N CR3243-4-2 (See Figure 3).
11. Reinstall the main rotor control rod assembly into the helicopter.
12. Install a bushing, P/N 28-16336-11, into the control rod fitting.
13. Install a pitch change bellcrank, P/N 28-14207-7 or -101, onto the mounting bracket and connect to the control rod fitting and the pitch change link.
14. Using special tool T-0054, install the dog leg rod end bearing.
15. Repeat the procedure for the other main rotor control rod assemblies.

16. Reassemble the helicopter and perform a maintenance test flight. Track the main rotor system as required.

## 5.2. REPLACEMENT:

### NOTE

Perform all maintenance procedures in accordance with the applicable aircraft maintenance manual.

1. Remove the main rotor pitch change bellcranks, P/N 28-14207-1.
2. Remove the main rotor control rod assemblies, P/N 28-16253-1.
3. Install a new main rotor control rod assembly, P/N 28-16253-101, into the helicopter.
4. Install a bushing, P/N 28-16336-11, into the control rod fitting.
5. Install a pitch change bellcrank, P/N 28-14207-7 or -101, onto the mounting bracket and connect to the control rod fitting and the pitch change link.
6. Using special tool T-0054, install the dog leg rod end bearing.
7. Repeat the procedure for the other main rotor control rod assemblies.
8. Reassemble the helicopter and perform a maintenance test flight. Track the main rotor system as required.

## 5.3. PARTS:

1. Parts required for main rotor control rod modification in accordance with paragraph 5.1:

<u>Description</u>	<u>Part Number</u>	<u>Quantity</u>
Main Rotor Pitch Change Bellcrank	28-14207-7 or 28-14207-101*	3 Ea
Main Rotor Control Rod Fitting	28-16253-15	3 Ea
Bearing	MS21240-08-C-12	3 Ea
Bushing	28-16336-11	3 Ea
Rivet	CR3243-4-2	12 Ea
Epoxy Primer	Aerospace Coatings 593 X 300 or Equivalent	A/R

2. Parts required for main rotor rod control replacement in accordance with paragraph 5.2:

<u>Description</u>	<u>Part Number</u>	<u>Quantity</u>
Main Rotor Pitch Change Bellcrank	28-14207-7 or 28-14207-101*	3 Ea
Main Rotor Control Rod Assembly	28-16253-101	3 Ea
Bushing	28-16336-11	3 Ea

- \* Pitch change bellcranks, P/N 28-14207-101, are life limited parts when installed on a TH-28/480 model helicopter. Component record cards are provided with these bellcranks and should be properly maintained to provide proper part history and serviceability records should the pitch change bellcrank be installed on a TH-28/480 model helicopter.

6. SPECIAL TOOLS: T-0054 - Dog Leg Alignment Tool
7. MAN-HOURS REQUIRED:

7 Man-hours for modification of the control rods. 6 Man-hours for installation of new control rods.

8. WARRANTY: Not applicable

9. WEIGHT CHANGE: None

10. LOG BOOK ENTRY:

Enter compliance with this Service Information Letter and the method of compliance, either modification or replacement of the control rod assemblies.

11. REPETITIVE INSPECTIONS:

Inspect in accordance with the applicable helicopter maintenance manual.

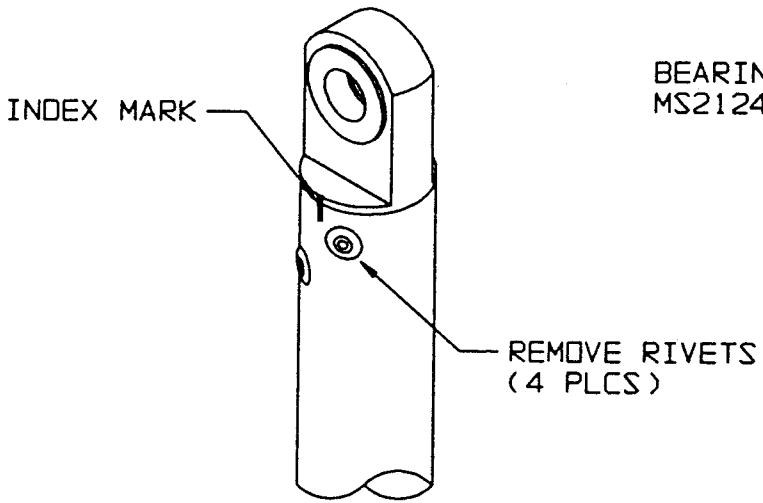

FIGURE 1

BEARING  
MS21240-08-C-12

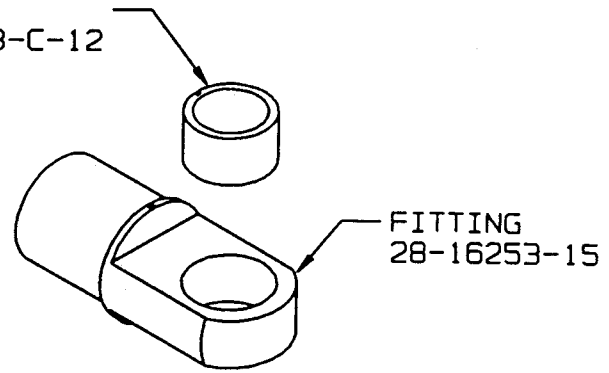

FIGURE 2

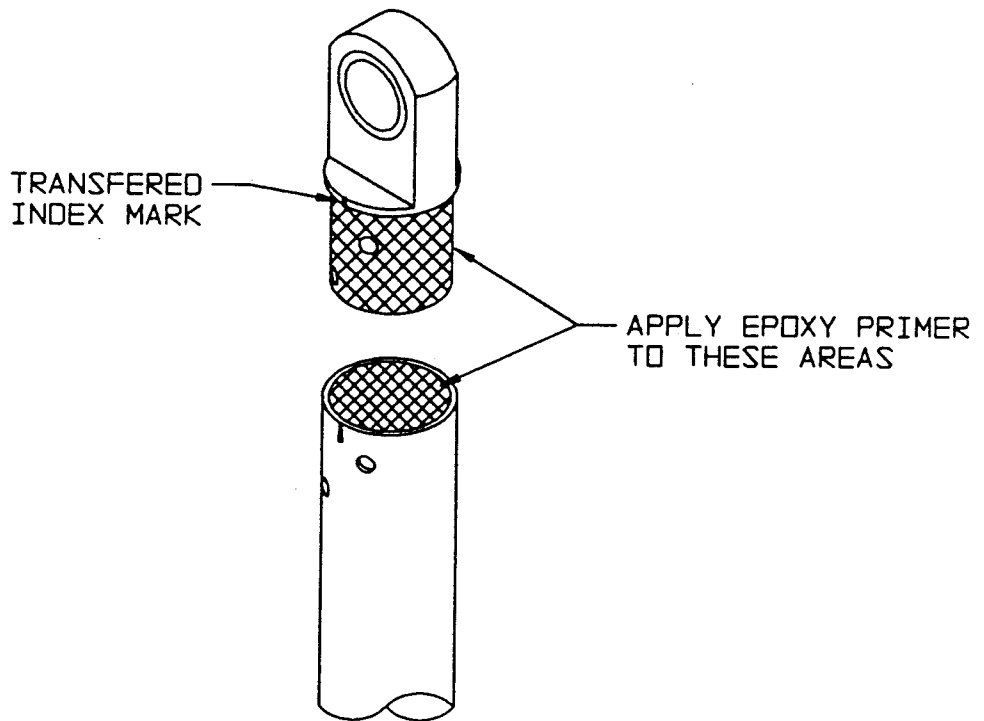

FIGURE 3