

April 16, 2024

Page 1 of 1

ENSTROM F-28/280 SERIES ILLUSTRATED PARTS CATALOG
1987 Edition

Revision 11, dated April 16, 2024 applies to the Enstrom F-28/280 Series Illustrated Parts Catalog, 1987 Edition. Place this cover sheet behind the "Log of Revisions" sheet at the front of your manual after removing and inserting the pages listed below.

<u>Remove Pages</u>	<u>Insert Pages</u>
i through xcvi	i through cxviii
3-1 through 3-2	3-1 through 3-2
3-17 through 3-20	3-17 through 3-20
3-75 through 3-76	3-75 through 3-76
3-83 through 3-85.1	3-83 through 3-85.1
3-93 through 3-95.1	3-93 through 3-95.1
3-113 through 3-114	3-113 through 3-114
3-117 through 3-120	3-117 through 3-120
3-123 through 3-124	3-123 through 3-124
7-0 through 7-57	7-1 through 7-108
12-0 through 12-29	12-1 through 12-60

* * * * End of List * * * *

INTENTIONALLY LEFT BLANK



**ENSTROM F-28/280 SERIES
ILLUSTRATED PARTS CATALOG
1987 EDITION**

MODEL EFFECTIVITY:
F-28A, 280, F-28C, 280C, F-28F, 280F, AND 280FX

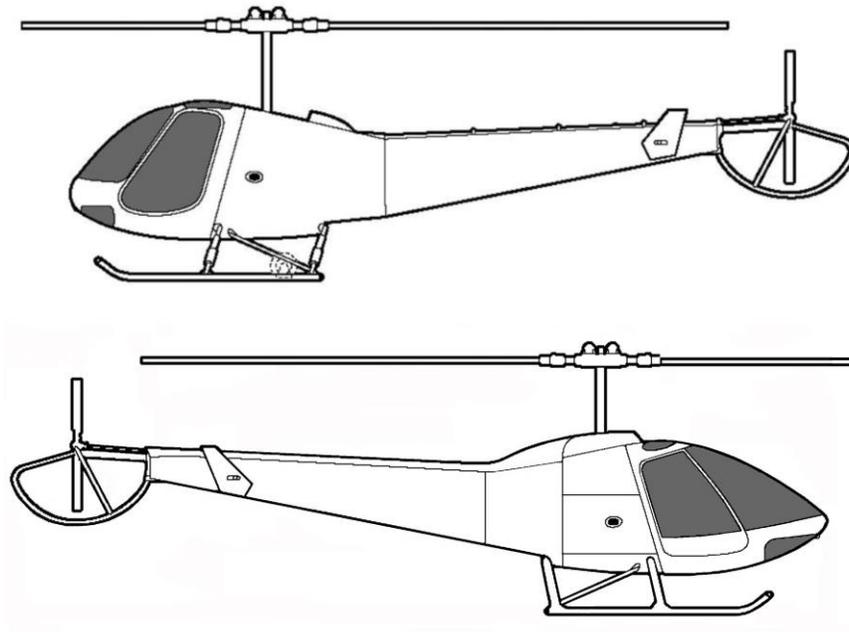

Download an electronic copy of this manual from the Technical Support page at
www.enstromhelicopter.com.

Copyright 1987-2024
The Enstrom Helicopter Corporation
2209 22nd Street
Menominee, Michigan 49858-3515

Telephone: 906-863-1200
Fax: 906-863-6821

ENSTROM F-28/280 SERIES ILLUSTRATED PARTS CATALOG

RECOMMENDED CHANGE REPORT

This Illustrated Parts Catalog (IPC) is prepared and distributed by The Enstrom Helicopter Corporation and is intended for use by personnel responsible for maintaining Enstrom F28A, 280, F28C, 280C, F28F, 280F, and 280FX helicopters. This manual is periodically revised. If, in the opinion of the user, any information has been omitted or requires clarification, please direct your comments to Enstrom via this form (duplicate) or other similar form. Send the recommended changes to:

Technical Publications
The Enstrom Helicopter Corporation
2209 22nd Street
Menominee, MI 49858-3515

Manual Identification: Enstrom F-28/280 Series Illustrated Parts Catalog

Manual Date: 1987

Revision Number and Date: _____

Aircraft Model: _____

Recommended Change:

ENSTROM F-28/280 SERIES ILLUSTRATED PARTS CATALOG

TABLE OF CONTENTS

Figure	Description	Page
	Title Page	i
	Recommended Change Report	ii
	Table of Contents	iii
	Effective Page List	ix
	Part Number Index	xviii
SECTION 1 – INTRODUCTION		
	Scope	1-2
	Introductory Information	1-2
	Detailed Parts List	1-3
	Appendices	1-4
SECTION 2 – PARTS ORDERING INFORMATION		
	General	2-2
	Parts Orders	2-2
	Shipment	2-3
	Emergency Requirements	2-3
	Credit Terms	2-3
SECTION 3 – POWER PLANT		
	Cover Page	3-1
	Table of Contents	3-1
3-1	Air Induction System (F-28A)	3-2
3-2	Air Induction System	3-4
3-3	Turbocharger Induction System	3-8
3-4	Fuel Nozzle Air Vent System	3-13
3-5	Engine Vent Installation	3-16
3-5A	Magneto Cooling Installation	3-18
3-6	Oil Cooler Installation (A Models)	3-21
3-7	Oil Cooler Installation (C, F Models)	3-24
3-8	Turbocharger Oil Lines	3-28
3-9	Oil Fill Tube Installation	3-31
3-10	Throttle and Mixture Control Installation (A, C Models)	3-34
3-11	Throttle Correlator Assembly (F Models)	3-40
3-12	Throttle Correlator Installation (F Models)	3-44
3-13	Dual Throttle Control Installation (F Models)	3-46
3-14	Throttle Cable Installation (F Models)	3-48
3-15	Mixture Cable Installation (F Models)	3-50
3-16	Fire Curtain Assembly (All Models)	3-53
3-17	Fire Curtain Installation (All Models)	3-55
3-18	Engine Fan Shroud Assembly (A Models)	3-59
3-19	Engine Fan Shroud Assembly (C Models)	3-63
3-20/A/B	Engine Fan Shroud Assembly (C, F Models)	3-66
3-21	Cooling Fan and Alternator Installation	3-96

ENSTROM F-28/280 SERIES ILLUSTRATED PARTS CATALOG

TABLE OF CONTENTS

Figure	Description	Page
3-22	Engine Fuel System (A Models)	3-98
3-23	Engine Fuel System (C, F Models)	3-103
3-24	Main Fuel System	3-108
3-25	Fuel Level Sending Unit	3-115
3-26	Fuel Shutoff Valve Assembly	3-117
3-27	Exhaust System Installation (A Models)	3-120
3-28	Exhaust System Installation (C, F Models)	3-122
3-29	Turbocharger Mount Installation	3-127
3-30	Engine Mount Assembly	3-130
3-31	Engine Components	3-132
SECTION 4 – MAIN ROTOR SYSTEM		
	Cover Page	4-1
	Table of Contents	4-1
4-1	Main Rotor Hub Assembly	4-2
4-2	Main Rotor Blade and Retention Assembly	4-6
4-2.1	Retention Assembly (STC SR03465CH)	4-10.1
4-3	Flapping Pin and Damper Installation	4-11
4-4	Hydraulic Damper Assembly (28-14375-101)	4-13
SECTION 5 – BELT DRIVE ASSEMBLY		
	Cover Page	5-1
	Table of Contents	5-1
5-1	Belt Tension Assembly and Installation	5-2
5-2	Spring Housing Assembly	5-7
5-3	Idler Pulley and Support Assembly	5-9
5-4	Jack Strut and Pulley Assembly	5-15
5-5	Main Drive Engagement Control System	5-21
5-6	Main Rotor Gearbox Installation	5-25
5-7	Main Rotor Transmission Seal Retainer Assembly	5-30
SECTION 6 – ELECTRICAL SYSTEM		
	Cover Page	6-1
	Table of Contents	6-1
6-1	Electrical Components (F-28A, 280)	6-2
6-2	Electrical Panels	6-5
6-3	12 Volt Battery Over-Current Breaker Installation	6-9
6-4	Landing Light and Anti-Collision Light (F-28A)	6-11
6-5	Night Lighting Kit (280 Models)	6-18
6-6	Strobe And Position Light Installation (C, F Models)	6-22
6-7	Forward Landing Light Installation (F-28C, F-28F)	6-28
6-8	Forward Landing Light Installation (280 Series)	6-31
6-9	Battery Installation (F-28A, 280)	6-33
6-10	12 Volt Battery Installation (C, F, FX Models)	6-35
6-11	Annunciator Systems Installation	6-37
6-12	Fuse Panel (F-28F, 280FX)	6-41

ENSTROM F-28/280 SERIES ILLUSTRATED PARTS CATALOG

TABLE OF CONTENTS

Figure	Description	Page
6-13	24 Volt Battery Installation (All Models)	6-43
6-14	Trim Relay Installation 24 Volt (F-28F, 280FX)	6-48

SECTION 7 – STRUCTURES

	Cover Page	7-1
	Table of Contents	7-1
7-1	Windows, Doors and Compartment Enclosures (F-28A, F-28C, F-28F)	7-3
7-2	Window Installation (F-28A, F-28C, F-28F)	7-13
7-3	Sliding Window Vent Installation (F-28F)	7-15
7-4	Door Assembly and Installation (F-28F S/N 745 & Sub)	7-19
7-5	Windows, Doors, and Compartment Enclosures (280, 280C, 280F, 280FX)	7-27
7-6	280FX Cabin Doors Assembly/Installation	7-37
7-7	280FX Cabin Closeout Installation	7-43
7-8	Cowling (F-28A, F-28C)	7-45
7-9	Cowling (280, 280C)	7-49
7-10	Cowling (F-28F, 280FX)	7-53
7-11	Engine Compartment Enclosures	7-61
7-12	Three-Piece Airscoop	7-65
7-13	Cabin Installation and Pylon and Tailcone Assembly	7-67
7-14	Tailcone Bulkhead and Skin Enclosures	7-71
7-15	Stabilizer and Tailcone Extension (F-28A, F-28C, F-28F)	7-75
7-16	Stabilizer and Tailcone Extension (280, 280C, 280F)	7-79
7-17	Stabilizer and Tailcone Extension (F-28F, 280FX)	7-83
7-18	Tail Rotor Drive Shaft Cover	7-87
7-19	Pylon Assembly to Landing Gear	7-91
7-20	Landing Gear Assembly	7-93
7-21	Oleo Strut Assembly	7-101
7-22	Landing Gear Fairings	7-105

SECTION 8 – FLIGHT CONTROLS

	Cover Page	8-1
	Table of Contents	8-1
8-1	Lower Swashplate Assembly	8-2
8-2	Lower Swashplate Installation	8-3
8-3	Lower Swashplate Control Rod Attachment	8-5
8-3A	Upper Swashplate Assembly & Control Attachment	8-6
8-4	Main Rotor Pitch Change Controls	8-7
8-5	Cyclic Control Assembly	8-8
8-5A	Cyclic Control Stick Assembly	8-18
8-6	Trim Spring Mechanical Installation	8-21
8-6A	Lateral and Longitudinal Bias Spring Installation	8-23
8-7	Lateral Trim With Bias Spring Installation	8-25
8-8	Trim Actuator Capsule Installation	8-27
8-9	Lateral Trim Assembly	8-29
8-10	Longitudinal Trim Assembly	8-32
8-11	Collective Trim, Spring Capsule	8-35
8-12	Co-Pilots Collective Assembly	8-37

ENSTROM F-28/280 SERIES ILLUSTRATED PARTS CATALOG

TABLE OF CONTENTS

Figure	Description	Page
8-13	Pilots Collective Assembly	8-39
8-14	Collective Control System Torque Shaft Assembly	8-41
8-15	Collective Control System Torque Shaft Assembly	8-44
8-16	Collective Control Reversing Bellcrank	8-46
8-16A	Collective Control Push-Pull Rod Attachment	8-47
8-16B	Collective Reversing Bellcrank Pivot	8-48
8-17	Collective Stick Friction Control	8-50

SECTION 9 – FURNISHINGS

	Cover Page	9-1
	Table of Contents	9-1
9-1	Cabin Seat Assembly	9-2
9-2	Cabin Furnishings (Non-Production Models)	9-5
9-3	Cabin Furnishings and Fire Extinguisher	9-8
9-4	280F/FX Cabin Furnishings	9-13
9-5	Cabin Furnishings – Passenger Restraint System	9-18

SECTION 10 – UTILITY SYSTEMS

	Cover Page	10-1
	Table of Contents	10-1
10-1	Cabin Heating Installation (F-28A)	10-2
10-2	Cabin Heating Installation (280)	10-4
10-3	Cabin Heating Installation (F-28C, 280C)	10-7
10-4	Cabin Heating Installation (Current Production)	10-10

SECTION 11 – INSTRUMENTS

	Cover Page	11-1
	Table of Contents	11-1
11-1	Early F-28A Instrument Panels	11-2
11-2	F-28C Instrument Panel Installation	11-6
11-3	280C and 280F Instrument Panel Installation	11-10
11-4	280 Instrument Panel Installation	11-15
11-5	F-28F and 280FX Instrument Panel Installation (12V)	11-19
11-6	F-28F and 280FX Instrument Panel Installation (24V)	11-26
11-7	F-28F Instrument Panel Installation (24V) (F-28F S/N 833 and Subsequent)	11-31
11-8	280FX Instruments and Instrument Panel (280FX S/N 2166 and prior)	11-40
11-9	280FX Instruments and Instrument Panel (280FX S/N 2167 and Subsequent)	11-50
11-10	F-28A and 280 Instrument Line Pylon Location	11-58
11-11	Pitot Static System Installation	11-60
11-12	Instrument Lines Cabin and Panel	11-63
11-13	F-28A and 280 Instrument Lines Cabin and Panel	11-65
11-14	Instrument Line Installation	11-67
11-15	Instrument/System Line Installation	11-70
11-16	Turbine Inlet Temperature Indicator Installation	11-75
11-17	Graphic Engine Monitor	11-77

ENSTROM F-28/280 SERIES ILLUSTRATED PARTS CATALOG

TABLE OF CONTENTS

Figure	Description	Page
11-18	Mechanical Tachometer Drive Installation	11-80
11-19	EDM-700-4C Installation	11-83
11-20	Placard Bracket Installation	11-90
11-21	Placard Installation	11-94

SECTION 12 – TAIL ROTOR

	Cover Page	12-1
	Table of Contents	12-1
12-1	Tail Rotor Transmission Assembly	12-3
12-2	Flex Coupling Installation	12-7
12-3	Tail Rotor Hanger Bearing Installation	12-11
12-4	Rotor Tachometer Assembly	12-13
12-5	Tail Rotor Blade Control Installation	12-17
12-6	Tail Rotor Pitch Link Assembly	12-29
12-7	Tail Rotor Mechanical Controls (Right Hand Gearbox)	12-33
12-8	Tail Rotor Mechanical Controls (Left Hand Gearbox)	12-37
12-9	28-15018-3 Tail Rotor Assembly	12-41
12-10	28-150000-7, -10 Tail Rotor Assembly	12-45
12-11	28-150050-2 Tail Rotor Assembly	12-49
12-12	28-150073-1, -5 Tail Rotor Assembly	12-53
12-13	28-150079-1, -5 Tail Rotor Assembly	12-57

SECTION 13 – SHIMS

	Cover Page	13-1
	Table of Contents	13-1
13-1	Index of Enstrom Helicopter Shims	13-2

APPENDIX A – EQUIVALENT PARTS

	Introduction	A-3
	Equivalent Parts Tables	A-3

APPENDIX B – STANDARD HARDWARE SUBSTITUTIONS

	Cover Page	B-1
	Table of Contents	B-1
	Introduction	B-2
	Acceptable Substitution Conditions	B-2
	Hardware Tables	B-2
	<i>Table A – Bolts</i>	B-3
	<i>Table B – Screws</i>	B-5
	<i>Table C – Nuts</i>	B-8
	<i>Table D – Nut Plates</i>	B-9
	<i>Table E – Solid Rivets</i>	B-11
	<i>Table F – Blind Rivets</i>	B-12
	<i>Table G – Washers</i>	B-13

ENSTROM F-28/280 SERIES ILLUSTRATED PARTS CATALOG

TABLE OF CONTENTS

Figure	Description	Page
	<i>Table H – Rivnuts</i>	B-15
	<i>Table I – Turnbuckles</i>	B-15
	<i>Table J – Grommets</i>	B-15
	<i>Table K – Cotter Pins</i>	B-16
	<i>Table L – Clamps (Nylon)</i>	B-17
	<i>Table M – Cable Ties</i>	B-17
	<i>Table N – U-Channel (Rubber)</i>	B-17
	<i>Table O – Shrink Tubing</i>	B-17
	<i>Table P – Ring Tongue Terminals</i>	B-18
	<i>Table Q – Retaining Rings</i>	B-18
	<i>Table R – Cushioned Clamps</i>	B-18
	<i>Table S – Plusnuts</i>	B-18
	<i>Table T – Solder Sleeve Shield Terminator</i>	B-19
	<i>Table U – Plug, Pipe – Countersink Hex Head</i>	B-19
	<i>Table V – Clip Nut</i>	B-19
	<i>Table W – Plug and Bleeder – Screw Thread</i>	B-19
	<i>Table X – Pin, Retaining, Safety</i>	B-19
	<i>Table Y – Quarter Turn Fastener</i>	B-19
	<i>Table Z – Quick Disconnect Terminal</i>	B-19
	<i>Table AA – Plug (BNC, TNC, N)</i>	B-19
	<i>Table AB – Roll Pin</i>	B-19
	<i>Table AC – Sleeve, Coupling</i>	B-19
	<i>Table AD – Clevis Pin</i>	B-20
	<i>Table AE – Quarter (1/4) Turn Fastener Receptacle</i>	B-20
	<i>Table AF – Washers, Extended AN960 Listing</i>	B-21

ENSTROM F-28/280 SERIES ILLUSTRATED PARTS CATALOG

EFFECTIVE PAGE LIST

Page	Date	Page	Date
i	Apr 16/24	I	Apr 16/24
ii	Aug 21/19	li	Apr 16/24
iii	Apr 16/24	lii	Apr 16/24
iv	Apr 16/24	liii	Apr 16/24
v	Apr 16/24	liiv	Apr 16/24
vi	Apr 16/24	lv	Apr 16/24
vii	Apr 16/24	lvi	Apr 16/24
viii	Apr 16/24	lvii	Apr 16/24
ix	Apr 16/24	lviii	Apr 16/24
x	Apr 16/24	lix	Apr 16/24
xi	Apr 16/24	lx	Apr 16/24
xii	Apr 16/24	lxi	Apr 16/24
xiii	Apr 16/24	lxii	Apr 16/24
xiv	Apr 16/24	lxiii	Apr 16/24
xv	Apr 16/24	lxiv	Apr 16/24
xvi	Apr 16/24	lxv	Apr 16/24
xvii	Apr 16/24	lxvi	Apr 16/24
xviii	Apr 16/24	lxvii	Apr 16/24
xix	Apr 16/24	lxviii	Apr 16/24
xx	Apr 16/24	lxix	Apr 16/24
xxi	Apr 16/24	lxx	Apr 16/24
xxii	Apr 16/24	lxxi	Apr 16/24
xxiii	Apr 16/24	lxxii	Apr 16/24
xxiv	Apr 16/24	lxxiii	Apr 16/24
xxv	Apr 16/24	lxxiv	Apr 16/24
xxvi	Apr 16/24	lxxv	Apr 16/24
xxvii	Apr 16/24	lxxvi	Apr 16/24
xxviii	Apr 16/24	lxxvii	Apr 16/24
xxix	Apr 16/24	lxxviii	Apr 16/24
xxx	Apr 16/24	lxxix	Apr 16/24
xxxi	Apr 16/24	lxxx	Apr 16/24
xxxii	Apr 16/24	lxxxi	Apr 16/24
xxxiii	Apr 16/24	lxxxii	Apr 16/24
xxxiv	Apr 16/24	lxxxiii	Apr 16/24
xxxv	Apr 16/24	lxxxiv	Apr 16/24
xxxvi	Apr 16/24	lxxxv	Apr 16/24
xxxvii	Apr 16/24	lxxxvi	Apr 16/24
xxxviii	Apr 16/24	lxxxvii	Apr 16/24
xxxix	Apr 16/24	lxxxviii	Apr 16/24
xl	Apr 16/24	lxxxix	Apr 16/24
xli	Apr 16/24	xc	Apr 16/24
xlii	Apr 16/24	xc i	Apr 16/24
xl iii	Apr 16/24	xc ii	Apr 16/24
xl iv	Apr 16/24	xc iii	Apr 16/24
xl v	Apr 16/24	xc iv	Apr 16/24
xl vi	Apr 16/24	xc v	Apr 16/24
xl vii	Apr 16/24	xc vi	Apr 16/24
xl viii	Apr 16/24	xc vii	Apr 16/24
xl ix	Apr 16/24		

ENSTROM F-28/280 SERIES ILLUSTRATED PARTS CATALOG

EFFECTIVE PAGE LIST

Page	Date	Page	Date
xcviii	Apr 16/24	3-20	Apr 16/24
xcix	Apr 16/24	3-21	Apr 22/19
c	Apr 16/24	3-22	Apr 22/19
ci	Apr 16/24	3-23	Apr 22/19
cii	Apr 16/24	3-24	Apr 22/19
ciii	Apr 16/24	3-25	Apr 22/19
civ	Apr 16/24	3-26	Apr 22/19
cv	Apr 16/24	3-27	Apr 22/19
cvi	Apr 16/24	3-28	Apr 22/19
cvii	Apr 16/24	3-29	Feb 27/23
cviii	Apr 16/24	3-30	Feb 27/23
cix	Apr 16/24	3-31	Apr 22/19
cx	Apr 16/24	3-32	Apr 22/19
cxI	Apr 16/24	3-33	Apr 22/19
cxii	Apr 16/24	3-34	Apr 22/19
cxiii	Apr 16/24	3-35	Apr 22/19
cxiv	Apr 16/24	3-36	Apr 22/19
cxv	Apr 16/24	3-37	Apr 22/19
cxvi	Apr 16/24	3-38	Apr 22/19
cxvii	Apr 16/24	3-39	Apr 22/19
cxviii	Apr 16/24	3-40	Apr 22/19
1-1	Apr 22/19	3-41	Nov 8/23
1-2	Feb 27/23	3-42	Nov 8/23
1-3	Apr 22/19	3-43	Nov 8/23
1-4	Apr 22/19	3-43.1	Nov 8/23
2-1	Apr 22/19	3-43.2	Nov 8/23
2-2	Apr 22/19	3-44	Apr 22/19
2-3	Apr 22/19	3-45	Apr 22/19
2-4	Apr 22/19	3-46	Apr 22/19
3-1	Apr 16/24	3-47	Apr 22/19
3-2	Apr 22/19	3-48	Apr 22/19
3-3	Apr 22/19	3-49	Apr 22/19
3-4	Apr 22/19	3-50	Apr 22/19
3-5	Apr 22/19	3-51	Apr 22/19
3-6	Apr 22/19	3-52	Apr 22/19
3-7	Feb 27/23	3-53	Apr 22/19
3-8	Feb 27/23	3-54	Apr 22/19
3-9	Apr 22/19	3-55	Apr 22/19
3-10	Feb 27/23	3-56	Apr 22/19
3-11	Apr 22/19	3-57	Apr 22/19
3-12	Apr 22/19	3-58	Apr 22/19
3-13	Feb 27/23	3-59	Apr 22/19
3-14	Feb 27/23	3-60	Apr 22/19
3-15	Feb 27/23	3-61	Apr 22/19
3-16	Apr 22/19	3-62	Apr 22/19
3-17	Apr 16/24	3-63	Apr 22/19
3-18	Apr 16/24	3-64	Apr 22/19
3-19	Apr 16/24	3-65	Apr 22/19
		3-66	Apr 22/19

ENSTROM F-28/280 SERIES ILLUSTRATED PARTS CATALOG

EFFECTIVE PAGE LIST

Page	Date	Page	Date
3-67	Apr 22/19	3-112	Feb 27/23
3-68	Feb 27/23	3-113	Feb 27/23
3-69	Apr 22/19	3-114	Apr 16/24
3-70	Feb 27/23	3-115	Apr 22/19
3-71	May 17/23	3-116	Apr 22/19
3-72	Feb 27/23	3-117	Apr 22/19
3-73	Feb 27/23	3-118	Apr 16/24
3-74	Feb 27/23	3-119	Apr 16/24
3-75	Apr 16/24	3-120	Apr 22/19
3-76	Feb 27/23	3-121	Apr 22/19
3-77	Feb 27/23	3-122	Apr 22/19
3-78	Feb 27/23	3-123	Aug 21/19
3-79	Apr 22/19	3-124	Apr 16/24
3-80	Apr 22/19	3-125	Apr 22/19
3-81	Feb 27/23	3-126	Nov 8/23
3-82	Feb 27/23	3-127	Apr 22/19
3-83	Apr 16/24	3-128	Apr 22/19
3-84	Apr 16/24	3-129	Apr 22/19
3-85	Apr 16/24	3-130	Apr 22/19
3-85.1	Apr 16/24	3-131	Apr 22/19
3-85.2	Feb 27/23	3-132	Aug 21/19
3-86	Feb 27/23	3-133	Aug 21/19
3-87	Apr 22/19	3-134	Aug 21/19
3-88	Aug 21/19	4-1	Feb 27/23
3-89	Apr 22/19	4-2	Apr 22/19
3-90	Apr 22/19	4-3	Apr 22/19
3-91	Feb 27/23	4-4	Feb 27/23
3-92	Feb 27/23	4-5	Feb 27/23
3-93	Apr 16/24	4-6	Feb 27/23
3-94	Apr 16/24	4-7	Aug 21/19
3-95	Apr 16/24	4-8	Feb 27/23
3-95.1	Feb 27/23	4-9	Feb 27/23
3-95.2	Feb 27/23	4-10	Feb 27/23
3-96	Apr 22/19	4-10.1	Feb 27/23
3-97	Apr 22/19	4-10.2	Feb 27/23
3-98	Apr 22/19	4-11	Aug 21/19
3-99	Feb 27/23	4-12	Aug 21/19
3-100	Feb 27/23	4-13	Aug 21/19
3-101	Feb 27/23	4-14	May 17/23
3-102	Apr 22/19	4-15	Aug 21/19
3-103	Apr 22/19	4-16	Aug 21/19
3-104	Feb 27/23	5-1	Feb 27/23
3-105	Feb 27/23	5-2	Apr 22/19
3-106	Feb 27/23	5-3	Apr 22/19
3-107	Aug 21/19	5-4	Apr 22/19
3-108	Apr 22/19	5-5	Apr 22/19
3-109	Apr 22/19	5-6	Apr 22/19
3-110	Feb 27/23	5-7	Apr 22/19
3-111	Feb 27/23	5-8	Feb 27/23

ENSTROM F-28/280 SERIES ILLUSTRATED PARTS CATALOG

EFFECTIVE PAGE LIST

Page	Date	Page	Date
5-9	Apr 22/19	6-22	Apr 22/19
5-10	Apr 22/19	6-23	Apr 22/19
5-11	Apr 22/19	6-24	Apr 22/19
5-12	Apr 22/19	6-25	Apr 22/19
5-13	Apr 22/19	6-26	Apr 22/19
5-14	Apr 22/19	6-27	Apr 22/19
5-15	Apr 22/19	6-28	Apr 22/19
5-16	Apr 22/19	6-29	Apr 22/19
5-17	Apr 22/19	6-30	Apr 22/19
5-18	Apr 22/19	6-31	Apr 22/19
5-19	Apr 22/19	6-32	Feb 27/23
5-20	Apr 22/19	6-33	Apr 22/19
5-21	Apr 22/19	6-34	Apr 22/19
5-22	Apr 22/19	6-35	Apr 22/19
5-23	Feb 27/23	6-36	May 17/23
5-24	Feb 27/23	6-37	Apr 22/19
5-25	Feb 27/23	6-38	Apr 22/19
5-25.1	Feb 27/23	6-39	Apr 22/19
5-25.2	Feb 27/23	6-40	Apr 22/19
5-26	Feb 27/23	6-41	Apr 22/19
5-27	Feb 27/23	6-42	Apr 22/19
5-28	Feb 27/23	6-43	Apr 22/19
5-29	Feb 27/23	6-44	Apr 22/19
5-30	Feb 27/23	6-45	Apr 22/19
5-31	Feb 27/23	6-46	Apr 22/19
5-32	Feb 27/23	6-47	Apr 22/19
6-1	Apr 22/19	6-48	Apr 22/19
6-2	Apr 22/19	6-49	Apr 22/19
6-3	Apr 22/19	6-50	Apr 22/19
6-4	Apr 22/19	7-1	Apr 16/24
6-5	Apr 22/19	7-2	Apr 16/24
6-6	Apr 22/19	7-3	Apr 16/24
6-7	Apr 22/19	7-4	Apr 16/24
6-8	Apr 22/19	7-5	Apr 16/24
6-9	Apr 22/19	7-6	Apr 16/24
6-10	Apr 22/19	7-7	Apr 16/24
6-11	Apr 22/19	7-8	Apr 16/24
6-12	Apr 22/19	7-9	Apr 16/24
6-13	Apr 22/19	7-10	Apr 16/24
6-14	Apr 22/19	7-11	Apr 16/24
6-15	Apr 22/19	7-12	Apr 16/24
6-16	Apr 22/19	7-13	Apr 16/24
6-17	Apr 22/19	7-14	Apr 16/24
6-18	Feb 27/23	7-15	Apr 16/24
6-19	Feb 27/23	7-16	Apr 16/24
6-20	Apr 22/19	7-17	Apr 16/24
6-21	Feb 27/23	7-18	Apr 16/24
6-21.1	Feb 27/23	7-19	Apr 16/24
6-21.2	Feb 27/23	7-20	Apr 16/24

ENSTROM F-28/280 SERIES ILLUSTRATED PARTS CATALOG

EFFECTIVE PAGE LIST

Page	Date	Page	Date
7-21	Apr 16/24	7-70	Apr 16/24
7-22	Apr 16/24	7-71	Apr 16/24
7-23	Apr 16/24	7-72	Apr 16/24
7-24	Apr 16/24	7-73	Apr 16/24
7-25	Apr 16/24	7-74	Apr 16/24
7-26	Apr 16/24	7-75	Apr 16/24
7-27	Apr 16/24	7-76	Apr 16/24
7-28	Apr 16/24	7-77	Apr 16/24
7-29	Apr 16/24	7-78	Apr 16/24
7-30	Apr 16/24	7-79	Apr 16/24
7-31	Apr 16/24	7-80	Apr 16/24
7-32	Apr 16/24	7-81	Apr 16/24
7-33	Apr 16/24	7-82	Apr 16/24
7-34	Apr 16/24	7-83	Apr 16/24
7-35	Apr 16/24	7-84	Apr 16/24
7-36	Apr 16/24	7-85	Apr 16/24
7-37	Apr 16/24	7-86	Apr 16/24
7-38	Apr 16/24	7-87	Apr 16/24
7-39	Apr 16/24	7-88	Apr 16/24
7-40	Apr 16/24	7-89	Apr 16/24
7-41	Apr 16/24	7-90	Apr 16/24
7-42	Apr 16/24	7-91	Apr 16/24
7-43	Apr 16/24	7-92	Apr 16/24
7-44	Apr 16/24	7-93	Apr 16/24
7-45	Apr 16/24	7-94	Apr 16/24
7-46	Apr 16/24	7-95	Apr 16/24
7-47	Apr 16/24	7-96	Apr 16/24
7-48	Apr 16/24	7-97	Apr 16/24
7-49	Apr 16/24	7-98	Apr 16/24
7-50	Apr 16/24	7-99	Apr 16/24
7-51	Apr 16/24	7-100	Apr 16/24
7-52	Apr 16/24	7-101	Apr 16/24
7-53	Apr 16/24	7-102	Apr 16/24
7-54	Apr 16/24	7-103	Apr 16/24
7-55	Apr 16/24	7-104	Apr 16/24
7-56	Apr 16/24	7-105	Apr 16/24
7-57	Apr 16/24	7-106	Apr 16/24
7-58	Apr 16/24	7-107	Apr 16/24
7-59	Apr 16/24	7-108	Apr 16/24
7-60	Apr 16/24	8-1	Nov 8/23
7-61	Apr 16/24	8-1.1	Nov 8/23
7-62	Apr 16/24	8-2	May 17/23
7-63	Apr 16/24	8-2.1	May 17/23
7-64	Apr 16/24	8-2.2	May 17/23
7-65	Apr 16/24	8-2.3	May 17/23
7-66	Apr 16/24	8-3	May 17/23
7-67	Apr 16/24	8-4	May 17/23
7-68	Apr 16/24	8-5	May 17/23
7-69	Apr 16/24	8-5A	May 17/23

ENSTROM F-28/280 SERIES ILLUSTRATED PARTS CATALOG

EFFECTIVE PAGE LIST

Page	Date	Page	Date
8-5.2	May 17/23	8-34.3	Nov 8/23
8-5.3	May 17/23	8-35	May 17/23
8-6	May 17/23	8-36	Feb 27/23
8-6.1	May 17/23	8-36.1	Feb 27/23
8-6.2	May 17/23	8-36.2	Feb 27/23
8-6.3	May 17/23	8-37	Original
8-6.4	May 17/23	8-38	Original
8-6.5	May 17/23	8-39	Original
8-7	May 17/23	8-40	Original
8-7.1	May 17/23	8-41	Original
8-7.2	May 17/23	8-42	Original
8-7.3	May 17/23	8-43	Original
8-8	May 17/23	8-44	Original
8-9	May 17/23	8-45	Original
8-10	May 17/23	8-46	Original
8-11	May 17/23	8-47	Original
8-12	May 17/23	8-48	Original
8-13	May 17/23	8-49	Original
8-14	May 17/23	8-50	Original
8-15	May 17/23	8-51	Original
8-16	May 17/23	9-1	Apr 22/19
8-17	May 17/23	9-2	Apr 22/19
8-18	May 17/23	9-3	Apr 22/19
8-19	May 17/23	9-4	Apr 22/19
8-20	May 17/23	9-5	Apr 22/19
8-20.1	May 17/23	9-6	Apr 22/19
8-21	Nov 8/23	9-7	Apr 22/19
8-22	Nov 8/23	9-8	Apr 22/19
8-23	Nov 8/23	9-9	Apr 22/19
8-24	Nov 8/23	9-10	Feb 27/23
8-24.1	Nov 8/23	9-11	Feb 27/23
8-24.2	Nov 8/23	9-12	Feb 27/23
8-25	Nov 8/23	9-13	Apr 22/19
8-26	Nov 8/23	9-14	Apr 22/19
8-27	Nov 8/23	9-15	Feb 27/23
8-28	Nov 8/23	9-16	Feb 27/23
8-28.1	Nov 8/23	9-17	Feb 27/23
8-28.2	Nov 8/23	9-18	Apr 22/19
8-29	Nov 8/23	9-19	Apr 22/19
8-30	Nov 8/23	9-20	Apr 22/19
8-31	Nov 8/23	9-21	Apr 22/19
8-31.1	Nov 8/23	9-22	Apr 22/19
8-31.2	Nov 8/23	10-1	Apr 22/19
8-31.3	Nov 8/23	10-2	Apr 22/19
8-32	Nov 8/23	10-3	Apr 22/19
8-33	Nov 8/23	10-4	Apr 22/19
8-34	Nov 8/23	10-5	Apr 22/19
8-34.1	Nov 8/23	10-6	Apr 22/19
8-34.2	Nov 8/23	10-7	Apr 22/19

ENSTROM F-28/280 SERIES ILLUSTRATED PARTS CATALOG

EFFECTIVE PAGE LIST

Page	Date	Page	Date
10-8	Apr 22/19	11-42	Nov 8/23
10-9	Apr 22/19	11-43	Nov 8/23
10-10	Apr 22/19	11-44	Nov 8/23
10-11	Apr 22/19	11-45	Nov 8/23
10-12	Apr 22/19	11-46	Nov 8/23
10-13	Apr 22/19	11-47	Nov 8/23
10-14	Apr 22/19	11-48	Nov 8/23
11-0	Nov 8/23	11-49	Nov 8/23
11-1	Nov 8/23	11-50	Nov 8/23
11-2	Nov 8/23	11-51	Nov 8/23
11-3	Nov 8/23	11-52	Nov 8/23
11-4	Nov 8/23	11-53	Nov 8/23
11-5	Nov 8/23	11-54	Nov 8/23
11-6	Nov 8/23	11-55	Nov 8/23
11-7	Nov 8/23	11-56	Nov 8/23
11-8	Nov 8/23	11-57	Nov 8/23
11-9	Nov 8/23	11-58	Nov 8/23
11-10	Nov 8/23	11-59	Nov 8/23
11-11	Nov 8/23	11-60	Nov 8/23
11-12	Nov 8/23	11-61	Nov 8/23
11-13	Nov 8/23	11-62	Nov 8/23
11-14	Nov 8/23	11-63	Nov 8/23
11-15	Nov 8/23	11-64	Nov 8/23
11-16	Nov 8/23	11-65	Nov 8/23
11-17	Nov 8/23	11-66	Nov 8/23
11-18	Nov 8/23	11-67	Nov 8/23
11-19	Nov 8/23	11-68	Nov 8/23
11-20	Nov 8/23	11-69	Nov 8/23
11-21	Nov 8/23	11-70	Nov 8/23
11-22	Nov 8/23	11-71	Nov 8/23
11-23	Nov 8/23	11-72	Nov 8/23
11-24	Nov 8/23	11-73	Nov 8/23
11-25	Nov 8/23	11-74	Nov 8/23
11-26	Nov 8/23	11-75	Nov 8/23
11-27	Nov 8/23	11-76	Nov 8/23
11-28	Nov 8/23	11-77	Nov 8/23
11-29	Nov 8/23	11-78	Nov 8/23
11-30	Nov 8/23	11-79	Nov 8/23
11-31	Nov 8/23	11-80	Nov 8/23
11-32	Nov 8/23	11-81	Nov 8/23
11-33	Nov 8/23	11-82	Nov 8/23
11-34	Nov 8/23	11-83	Nov 8/23
11-35	Nov 8/23	11-84	Nov 8/23
11-36	Nov 8/23	11-85	Nov 8/23
11-37	Nov 8/23	11-86	Nov 8/23
11-38	Nov 8/23	11-87	Nov 8/23
11-39	Nov 8/23	11-88	Nov 8/23
11-40	Nov 8/23	11-89	Nov 8/23
11-41	Nov 8/23	11-90	Nov 8/23

ENSTROM F-28/280 SERIES ILLUSTRATED PARTS CATALOG

EFFECTIVE PAGE LIST

Page	Date	Page	Date
11-91	Nov 8/23	12-28	Apr 16/24
11-92	Nov 8/23	12-29	Apr 16/24
11-93	Nov 8/23	12-30	Apr 16/24
11-94	Nov 8/23	12-31	Apr 16/24
11-95	Nov 8/23	12-32	Apr 16/24
11-96	Nov 8/23	12-33	Apr 16/24
11-97	Nov 8/23	12-34	Apr 16/24
11-98	Nov 8/23	12-35	Apr 16/24
11-99	Nov 8/23	12-36	Apr 16/24
11-100	Nov 8/23	12-37	Apr 16/24
11-101	Nov 8/23	12-38	Apr 16/24
11-102	Nov 8/23	12-39	Apr 16/24
11-103	Nov 8/23	12-40	Apr 16/24
11-104	Nov 8/23	12-41	Apr 16/24
11-105	Nov 8/23	12-42	Apr 16/24
11-106	Nov 8/23	12-43	Apr 16/24
11-107	Nov 8/23	12-44	Apr 16/24
11-108	Nov 8/23	12-45	Apr 16/24
11-109	Nov 8/23	12-46	Apr 16/24
11-110	Nov 8/23	12-47	Apr 16/24
11-111	Nov 8/23	12-48	Apr 16/24
11-112	Nov 8/23	12-49	Apr 16/24
12-1	Apr 16/24	12-50	Apr 16/24
12-2	Apr 16/24	12-51	Apr 16/24
12-3	Apr 16/24	12-52	Apr 16/24
12-4	Apr 16/24	12-53	Apr 16/24
12-5	Apr 16/24	12-54	Apr 16/24
12-6	Apr 16/24	12-55	Apr 16/24
12-7	Apr 16/24	12-56	Apr 16/24
12-8	Apr 16/24	12-57	Apr 16/24
12-9	Apr 16/24	12-58	Apr 16/24
12-10	Apr 16/24	12-59	Apr 16/24
12-11	Apr 16/24	12-60	Apr 16/24
12-12	Apr 16/24	13-1	Apr 22/19
12-13	Apr 16/24	13-2	Apr 22/19
12-14	Apr 16/24	A-1	Sep 30/13
12-15	Apr 16/24	A-2	Sep 30/13
12-16	Apr 16/24	A-3	Mar 24/17
12-17	Apr 16/24	A-4	Feb 27/23
12-18	Apr 16/24	A-5	Mar 24/17
12-19	Apr 16/24	A-6	Mar 24/17
12-20	Apr 16/24	B-1	Feb 27/23
12-21	Apr 16/24	B-2	Feb 27/23
12-22	Apr 16/24	B-3	Feb 27/23
12-23	Apr 16/24	B-4	Feb 27/23
12-24	Apr 16/24	B-5	Feb 27/23
12-25	Apr 16/24	B-6	Feb 27/23
12-26	Apr 16/24	B-7	Feb 27/23
12-27	Apr 16/24	B-8	Feb 27/23

ENSTROM F-28/280 SERIES ILLUSTRATED PARTS CATALOG

EFFECTIVE PAGE LIST

Page	Date	Page	Date
B-9	Feb 27/23	B-17	Feb 27/23
B-10	Feb 27/23	B-18	Feb 27/23
B-11	Feb 27/23	B-19	Feb 27/23
B-12	Feb 27/23	B-20	Feb 27/23
B-13	Feb 27/23	B-21	Feb 27/23
B-14	Feb 27/23	B-22	Feb 27/23
B-15	Feb 27/23	B-23	Feb 27/23
B-16	Feb 27/23	B-24	Feb 27/23

ENSTROM F-28/280 SERIES ILLUSTRATED PARTS CATALOG

PART NUMBER INDEX SECTIONS 3 THROUGH 7 AND 9 THROUGH 12 FIGURES 8-1 THROUGH 8-11

Part Number	Figure	Item	Part Number	Figure	Item
#1357	12-5	–	02-03705534-00	6-4	–
#4016	7-2	140	02-691-04	5-2	170
#4316	7-9	430	02A21376	3-23	650
#8x1/2	7-8	190	02A22619	3-8	190
00-15073-01	3-30	30A	037360-004	3-28	–
01-0770001-41	6-4	20	037360-104	3-3	280
01-0770001-51	6-4	10	037360-115	3-3	160
01-0770006-08	6-6	150A	037360-124	3-28	–
01-0770028-05	6-6	150	037360-160	3-3	280
01-0770028-05	6-6	150A	037360-161	3-3	160
01-0770029	6-4	140	037360-161	3-3	280
01-0770029-R	6-6	90	07DU08	5-2	140
01-0770034-02	6-5	180	08DU08	8-1	190
01-0770054-00	6-5	130	09455-01-824-08E-011	5-3	520
01-0770054-02	6-5	120	099001-174	3-27	20
01-0770119-09	6-4	350	099001-176	3-27	10
01-0770119-15	11-8	80	099001-177	3-27	30
01-0770119-15	11-9	90	099001-178	3-27	40
01-0790006-00	6-5	150	099005-401	3-27	50
01-0790006-01	6-5	170	09-DU-10	8-10	390
01-0790006-02	6-5	140	09-DU-12	8-9	400
01-0790006-03	6-5	160	09-DU-12	8-10	400
01-0790340-03	6-5	170	1	3-3	320
01-0790340-04	6-5	160	1	3-4	80
0110	11-1	–	1/2 X 8R	7-11	360
0110	11-2	–	1/2-6NA	11-19	225
0110	11-3	–	1/4 Harper	12-6	90
0110	11-4	300	1/4 Harper	12-7	140
01-691-04	12-6	160	1/4 Harper	3-3	60
01-691-04	12-5	640	1/4 Harper	5-1	110
01-691-05	8-4	100	1/4 Harper	5-3	370
01-824-08E-011	4-4	200	1/4 Harper	5-5	120
01-824-08E-011	5-3	520	1/4 Harper	8-11	160
02-0250276-00	6-6	130	1/4 Harper	8-11	20
02-0350003-01	6-4	–	1/4 Harper	8-3	110
02-0350003-01	6-4	–	1/4 Harper	8-5	350
02-0350003-01	6-4	–	1/4 Harper	12-13	290
02-0350281-0	6-4	–	1/4 Harper	8-8	120

ENSTROM F-28/280 SERIES ILLUSTRATED PARTS CATALOG

PART NUMBER INDEX SECTIONS 3 THROUGH 7 AND 9 THROUGH 12 FIGURES 8-1 THROUGH 8-11

Part Number	Figure	Item	Part Number	Figure	Item
1/4 Harper	7-1	250	1102	5-6	244
1/4 Harper	12-10	170	110927-3	7-5	680
1/4 Harper	12-11	220	1-10-AM5201	9-5	5
1/4 Harper	12-12	260	11-691-04	12-6	140
1/4" O.D. X 24" Long	6-13	150	11-691-05	8-4	130
1/4-6NA	11-16	40	1219-4200-Z3Y	3-2	113
1/8"	6-13	160	1219-4200-Z3Y	3-20	-
1/8-6NA	6-4	190	1219-4200-Z3Y	3-20B	-
1/8X8-32	3-24	450	1219-4200-Z3Y	3-20B	-
10005498	3-26	50	1219-4200-Z3Y	7-10	390
10065 H1L5	4-2	80	1239	3-9	21
101678-0002	3-8	110	12500750	4-4	140
10-176485-121	6-1	100	12500750-125B	4-4	140
102-00007	5-6	170	12528Y-A164	12-4	20
10-357290-1	11-8	275	12B	9-2	35
10-357290-1	11-9	165	12LHTA17-M62	3-18	-
10-357290-1	11-1	270	12LHTA1-M62	3-18	-
10-357290-1	11-2	160	12T35-2	11-5	160
10-357290-1	11-3	160	12TS15-2	11-8	265
10-357290-1	11-5	10	12TS15-2	11-9	150
10-357290-1	11-6	370	12TS15-2	11-5	160
10-357290-1	11-7	580	12TS15-2	11-7	560
103574-00	3-3	200	13241-LDS	5-6	-
10-382780-12	6-2	40	1425	7-5	-
1040	11-8	90	1-480305-0	11-8	-
1040	11-9	85	1-480318-0	11-7	-
1040	11-1	410	1-480319-0	6-11	-
1040	11-2	310	1-480319-0	11-7	-
1040	11-3	310	149-24HT	3-31	-
1040	11-4	290	1500-052-1	11-1	330
1040	11-5	40	1500-052-1	11-2	220
1040	11-6	170	1500-052-1	11-3	220
1040	11-7	190	1500-052-1	11-4	220
10-400608-123	6-1	100	1500-052-1	11-5	230A
10-400608-123	6-2	40	1500-052-2	6-3	-
10-400608-243	6-2	40	1500-052-2	11-1	70
1053	7-4	290	1500-052-2	11-5	250
1061	3-24	-	1500-052-2	11-6	190

ENSTROM F-28/280 SERIES ILLUSTRATED PARTS CATALOG

PART NUMBER INDEX SECTIONS 3 THROUGH 7 AND 9 THROUGH 12 FIGURES 8-1 THROUGH 8-11

Part Number	Figure	Item	Part Number	Figure	Item
1500-052-205	11-5	230	1650	12-11	200
1500-052-205	11-6	400	1650	12-12	200
1500-056-3	11-6	410	1678	11-9	180
15-0007-5	6-5	10	1684	11-8	200
1512	6-6	350	1684	11-7	430
1512-140	6-4	90	1687	11-8	245
1539-001	12-1	200	1687	11-7	530
1540	5-6	–	1691-C	3-8	120
1540	5-7	90	169E-190-12L	11-2	140
15753XC2L	7-1	370	169E-909-2L	11-1	240
1592-30	11-1	–	169E-909-2L	11-2	130
1592-30	11-2	–	169E-909-2L	11-3	130
1592-30	11-3	–	169E-909-2L	11-4	130
1592-30	11-4	–	169E-909-3L	11-3	–
1592-30	11-5	–	169E-910-11-3L	11-3	–
15PA90-4R	11-8	270	169E-910-11L	11-1	230
15PA90-4R	11-9	155	169E-910-11L	11-2	120
15PA90-4R	11-7	570	169E-910-11L	11-3	120
160-012-70	11-8	190	169E-910-11L	11-4	120
160-012-70	11-9	160	169E-910-12-1L	11-3	–
160-012-70	11-7	410	169E-910-12L	11-1	250
16-1	12-13	320	169E-910-12L	11-3	140
16-1	12-5	–	169E-910-12L	11-4	140
16-1	12-11	40	169E-910-14-4L	11-1	200
16-1	12-12	290	169E-910-14-4L	11-2	90
1637-B	12-3	50	169E-910-14-4L	11-3	90
1637-B	4-1	330	169E-910-14-4L	11-4	90
1637-B	8-1	70	169E-910-14-5L	11-3	–
1637-B1	8-3A	180	169E-910-15-1L	11-3	–
1641	12-9	–	169E-910-15L	11-1	220
1641-B	4-1	260	169E-910-15L	11-2	110
1641-B	4-2	160	169E-910-15L	11-3	110
1641-B	5-4	320	169E-910-15L	11-4	110
1641-B	8-4	90	169E-914-1L	11-1	210
1650	4-2	160	169E-914-1L	11-2	100
1650	5-4	130	169E-914-1L	11-3	100
1650	12-13	220	169E-914-1L	11-4	100
1650	12-10	190	169E-914-2L	11-3	–

ENSTROM F-28/280 SERIES ILLUSTRATED PARTS CATALOG

PART NUMBER INDEX SECTIONS 3 THROUGH 7 AND 9 THROUGH 12 FIGURES 8-1 THROUGH 8-11

Part Number	Figure	Item	Part Number	Figure	Item
16DU12	8-5	230	20044S	10-1	4
16-DU-12	8-3A	60	20-0824130A00	6-4	-
16-DU-14	8-3A	60	2-010	3-26	80
16-DU-16	8-3A	60	201F-5006	3-31	-
1728-B	5-3	270	201NP	5-3	300
1815	11-1	-	20206A	3-7	310
1815	11-3	-	2-025 E515-80	4-4	110
1815	11-5	-	2-025 E515-80	4-4	40
1816	6-4	120	2-026	3-9	60
1816	6-5	20	2-029	4-2	140
18207	3-26	150	202A-13BTR	11-3	330
18286-00	3-26	130	202A-13BTR	11-5	270
18-2-G	12-5	780	202A-13BTR	11-16	10
183204	3-26	150	202A-1A	11-2	330
184969	3-4	120	202A-1ATR	11-4	-
1877	12-13	110	20526	5-4	290
1885	12-11	150	206036-1	8-5	190
1886	11-18	130	206037-1	8-5	200
1886	12-4	150	206044-1	8-5	200A
1911-B	4-1	320	206070-1	8-5	210
1911-B	5-4	320	206322-1	8-5	210A
1911-B	8-3A	180	20TC2-CA-10	11-6	-470A
1911-B1	11-18	70	20TC2-CA-15	11-1	280
1911-B1	12-4	140	20TC2-CA-15	11-2	170
1911-B1	8-1	70	20TC2-CA-20	11-1	300
19-130074-009	6-6	100	20TC2-CA-20	11-2	190
19-150002-009	6-4	-	20TC2-CA-20	11-3	190
19-150002-009	6-4	-	20TC2-CA-20	11-4	190
19-150002-009	6-4	-	20TC2-CA-20	11-5	200A
1B7536	5-6	135	20TC2-CA-20	11-6	470
1SE1	5-1	310	20TC2-CA-3	11-1	260
2000653-001	6-5	10	20TC2-CA-3	11-2	150
20020S	7-22	250	20TC2-CA-3	11-3	150
20024S	7-22	270	20TC2-CA-3	11-4	150
20040S	10-1	18	20TC2-CA-3	11-5	190A
20040S	3-3	260	20TC2-CA-3	11-6	480
20042A	3-6	10	20TC2-CA-5	11-3	170
20042A	3-7	180	20TC2-CA-5	11-4	170

ENSTROM F-28/280 SERIES ILLUSTRATED PARTS CATALOG

PART NUMBER INDEX SECTIONS 3 THROUGH 7 AND 9 THROUGH 12 FIGURES 8-1 THROUGH 8-11

Part Number	Figure	Item	Part Number	Figure	Item
20TC2-CA-5	11-5	180A	222	11-5	–
20TC2-CA-5	11-6	460	22-370-60	11-8	405
20TC2-CA-7.5	11-1	140	22-370-60	11-9	315
20TC2-CA-7.5	11-1	290	22-370-60	11-1	–
20TC2-CA-7.5	11-2	30	22-370-60	11-2	–
20TC2-CA-7.5	11-2	180	22-370-60	11-3	–
20TC2-CA-7.5	11-3	30	22-370-60	11-4	–
20TC2-CA-7.5	11-3	180	22-370-60	11-5	–
20TC2-CA-7.5	11-3	210	22-370-60	11-7	880
20TC2-CA-7.5	11-3	230	229001P	6-12	70
20TC2-CA-7.5	11-4	30	22NKM-82	7-4	200
20TC2-CA-7.5	11-4	160	2-326 E515-80	4-4	90
20TC2-CA-7.5	11-4	180	2335-265-1	11-8	460
20TC2-CA-7.5	11-4	210	2335-265-1	11-9	370
20TC2-CA-7.5	11-4	230	2335-265-1	11-5	–
20TC2-CA-7.5	11-5	170A	2335-265-1	11-7	980
20TC2-CA-7.5	11-6	–460A	23S-094-0625	4-3	70
210A155	8-9	100	2500-4	7-5	780
210A155	8-10	100	2524917-1	3-31	–
210A249	8-9	–110	270624141H0080	3-22	220
210A249	8-10	–110	2716-00	11-5	–
2-131 N304-75	7-21	80	28-00013-1	11-21	190
2-137 E515-80	4-4	150	28-00013-3	11-21	200
21FA-540	12-1	130	28-00014-1	11-21	10
21FA-540	5-6	–	28-00014-3	11-21	20
2212A	3-22	250	28-00015-1	11-21	30
2212A	3-23	260	28-00015-3	11-21	40
2-214	3-9	70	28-00016-1	11-21	50
2-214	5-6	200	28-00016-3	11-21	60
22-169-09-1L	11-1	190	28-00017-1	11-21	–
22-169-09-1L	11-2	80	28-00018-1	11-21	–
22-169-09-1L	11-3	80	28-01011-3	6-13	200
22-169-09-1L	11-4	80	28-01026-1	11-5	270B
2-218	3-9	40	28-01026-11	11-19	70
222	11-1	380	28-01026-11	11-17	–
222	11-2	280	28-01026-3	11-5	270A
222	11-3	280	28-01026-3	11-17	–
222	11-4	–	28-01039-1	3-3	–

ENSTROM F-28/280 SERIES ILLUSTRATED PARTS CATALOG

PART NUMBER INDEX SECTIONS 3 THROUGH 7 AND 9 THROUGH 12 FIGURES 8-1 THROUGH 8-11

Part Number	Figure	Item	Part Number	Figure	Item
28-01041-1	12-2	120	280-113033-1	9-1	1B
28-01041-3	12-2	120	280-113033-3	9-1	1C
28-01058-15	3-5A	-	280-113035-1	7-5	840
28-01058-3	3-5A	140	280-113035-11	7-5	-
280-112000-1	7-13	-	280-113035-12	7-5	-
280-112000-3	7-13	-	280-113035-2	7-5	-850
280-112000-5	7-13	-	280-113036-1	7-5	960
280-112001-11	7-14	70	280-113036-11	7-5	-
280-112001-12	7-14	80	280-113036-13	7-5	-
280-112001-13	7-14	-60	280-113036-15	7-5	-
280-112001-15	7-14	-120	280-113036-3	7-5	-960A
280-112002-1	7-14	-190	280-113036-5	7-5	-960B
280-112002-3	7-14	-200	280-113037-1	7-5	970
280-112006-11	7-14	240	280-113037-11	7-5	970
280-113000-103	7-5	-	280-113037-13	7-5	970
280-113001-9	7-5	-	280-113038-11	7-5	-610
280-113006-19	3-10	20	280-113038-12	7-5	620
280-113016-29	6-10	80	280-113039-11	7-5	810
280-113016-31	6-10	90	280-114500-13	7-5	210
280-113019-31	6-9	80	280-114500-13	7-10	520
280-113022-11	7-5	-20	280-114500-17	7-9	-280
280-113022-12	7-5	10	280-114500-17	7-10	420
280-113022-13	7-5	80	280-114500-18	7-9	290
280-113022-14	7-5	90	280-114500-18	7-10	-430
280-113022-15	7-5	110	280-114500-19	7-10	370
280-113022-16	7-5	120	280-114500-20	7-10	-380
280-113022-17	7-5	30	280-114500-21	7-10	540
280-113023-1	7-5	-	280-114500-22	7-10	-550
280-113024-1	7-5	130	280-114500-23	7-10	560
280-113027-1	7-5	700	280-114500-24	7-10	-570
280-113027-13	7-5	760	280-114501-1	7-9	10
280-113027-14	7-5	-770	280-114501-5	7-10	500
280-113027-2	7-5	-710	280-114502-1	7-11	-210
280-113027-23	7-5	720	280-114502-3	7-10	140
280-113027-24	7-5	-730	280-114502-3	7-11	180
280-113027-31	7-5	740	280-114502-4	7-10	150
280-113032-11	7-5	910	280-114502-4	7-11	190
280-113032-12	7-5	-920	280-114502-5	7-9	180

ENSTROM F-28/280 SERIES ILLUSTRATED PARTS CATALOG

PART NUMBER INDEX SECTIONS 3 THROUGH 7 AND 9 THROUGH 12 FIGURES 8-1 THROUGH 8-11

Part Number	Figure	Item	Part Number	Figure	Item
280-114503-1	7-9	220	280-117003-2	7-5	420
280-114503-1	7-11	-330	280-117003-27	7-5	470
280-114503-3	7-9	-190	280-117003-3	7-5	-540
280-114503-3	7-11	-20	280-117003-4	7-5	550
280-114503-4	7-9	200	280-124001-1	3-22	10
280-114503-4	7-11	-40	280-124001-1	3-23	10
280-114503-5	7-9	260	280-124001-1	3-24	490
280-114503-5	7-11	-250	280-124001-1	3-26	-
280-114503-6	7-9	270	280-124001-3	3-26	190
280-114503-6	7-11	-260	280-124301-1	3-24	10
280-114504-1	7-9	150	280-124301-15	3-24	-
280-114505-2	7-9	370	280-124301-16	3-24	-
280-114505-2	7-10	190	280-124301-2	3-24	20
280-114507-1	7-5	160	280-124301-901	3-24	10
280-114507-1	7-10	90	280-124301-902	3-24	20
280-114507-3	7-5	-160A	280-126001-109	3-20	-
280-114507-3	7-10	60	280-126001-109	3-20A	-
280-114508-1	7-9	410	280-126001-109	3-20B	-
280-114508-1	7-10	240	280-126001-11	3-20B	-
280-114508-1	7-11	490	280-126001-15	3-20	-
280-114508-11	7-9	410	280-126001-15	3-20A	-
280-114508-11	7-11	490	280-126001-15	3-20B	-
280-114509-1	7-9	20	280-126001-3	3-20B	-
280-117000-1	7-5	-	280-126001-33	3-19	90
280-117000-10	7-5	560	280-126001-33	3-20B	-
280-117000-15	7-5	570	280-126001-34	3-20	-
280-117000-17	7-5	350	280-126001-35	3-19	110
280-117000-2	7-5	-	280-126001-37	3-19	130
280-117000-25	7-5	-360	280-126001-39	3-19	120
280-117000-26	7-5	370	280-126001-41	3-19	100
280-117001-15	7-5	290	280-126001-45	3-6	290
280-117001-23	7-5	300	280-126001-45	3-7	220
280-117001-25	7-5	520	280-126001-47	3-6	280
280-117001-3	7-5	480	280-126001-47	3-7	230
280-117001-5	7-5	500	280-126001-51	3-19	80
280-117001-7	7-5	490	280-126001-51	3-20	-
280-117002-1	7-5	320	280-126001-51	3-20B	-
280-117003-1	7-5	-410	280-126001-53	3-20	-

ENSTROM F-28/280 SERIES ILLUSTRATED PARTS CATALOG

PART NUMBER INDEX SECTIONS 3 THROUGH 7 AND 9 THROUGH 12 FIGURES 8-1 THROUGH 8-11

Part Number	Figure	Item	Part Number	Figure	Item
280-126001-53	3-20A	–	280-180004-21	11-4	260
280-126001-53	3-20B	–	280-180004-25	11-6	160
280-126001-55	3-20	–	280-180005-1	11-4	320
280-126001-55	3-20A	–	280-180005-2	11-4	310
280-126001-55	3-20B	–	280-180006-1	9-2	6
280-126001-69	3-20	610	280-180007-1	11-21	1090
280-126001-69	3-20A	610	280-181000-1	11-15	–
280-126001-69	3-20B	610	280-181000-11	11-15	30
280-126001-9	3-20	210	280-181000-13	11-15	35
280-126001-9	3-20A	210	280-181000-13	11-14	–40A
280-126001-9	3-20B	210	280-181000-15	11-15	40
280-126001-906	3-20B	20	280-181000-17	11-15	5
280-126001-908	3-20	20	280-181000-19	11-15	10
280-126001-908	3-20A	20	280-181000-21	11-15	70
280-126002-1	3-6	190	280-181000-23	11-15	45
280-126002-1	3-7	210	280-181000-25	11-15	50
280-126003-1	3-6	240	280-181000-911	11-12	–110A
280-126003-1	3-7	170	280-181000-911	11-14	–30A
280-126003-1	7-11	390	280-181000-913	11-12	–90A
280-127500-11	10-2	16	280-181000-915	11-12	–100A
280-127502-1	10-2	20	280-181000-915	11-14	–50A
280-127505-13	10-2	18	280-181000-917	11-12	–80A
280-127505-17	3-18	–	280-181000-917	11-14	–60A
280-127505-17	3-20	–	280-181000-919	11-12	–60A
280-127505-17	3-20A	–	280-181000-919	11-14	–70A
280-127505-17	3-20B	–	280-181000-921	11-12	–70A
280-127505-17	3-5A	70	280-181000-921	11-14	–80A
280-127507-11	10-2	17	280-200000-1	7-16	10
280-128000-2	7-5	150	280-200000-2	7-16	20
280-180000	11-3	–	280-201000-1	7-16	190
280-180000	11-4	–	280-201000-33	7-16	180
280-180001-11	9-2	9	280-201000-41	7-16	170
280-180001-12	9-2	8	280-201002-11	7-16	250
280-180001-13	9-2	10	280-210002-1	7-16	230
280-180003-3	11-6	300	280-210004-5	6-5	–
280-180004	11-3	250	280-210007-1	6-8	30
280-180004-19	11-4	250	280-210007-11	6-8	–
280-180004-21	11-3	260	280-210007-13	6-8	–

ENSTROM F-28/280 SERIES ILLUSTRATED PARTS CATALOG

PART NUMBER INDEX SECTIONS 3 THROUGH 7 AND 9 THROUGH 12 FIGURES 8-1 THROUGH 8-11

Part Number	Figure	Item	Part Number	Figure	Item
280-210007-3	6-8	30	28-11217-3	7-15	160
280-221001	9-3	-	28-11217-3	7-16	100
28-10-60-11	6-13	210	28-11218-1	7-15	150
28-111004-1	3-10	130	28-11218-1	7-16	90
28-111004-1	3-15	150	28-11221-1	7-15	80
28-111004-15	3-15	150	28-11221-2	7-15	90
28-111004-17	3-15	150	28-11222-1	7-15	130
28-11112-1	3-6	140	28-11222-15	7-17	80
28-11112-1	3-7	110	28-11225-11	7-14	230
28-11120-1	11-11	160	28-11227-13	7-18	-
28-11121-4	11-11	210	28-11227-13	7-18	-
28-11121-4	11-14	80	28-11227-17	7-18	-
28-11121-7	11-11	170	28-11227-17	7-18	-
28-11121-901	11-11	230	28-11227-21	7-18	-
28-11121-901	11-12	70	28-11227-21	7-18	-
28-11128-1	5-1	460	28-11236-1	7-14	-
28-11201-12	7-14	100	28-11236-1	7-15	-
28-11201-3	7-14	30	28-11236-1	7-16	-
28-11201-4	7-14	40	28-11236-31	7-14	-110
28-11201-5	7-14	20	28-11236-5	7-14	-
28-11201-6	7-14	10	28-11236-5	7-18	-
28-11201-7	7-14	50	28-11238-1	12-3	-55
28-11201-8	7-14	90	28-11239-1	7-18	10
28-11201-996	7-14	-	28-11239-101	7-18	40
28-11202-1	7-14	150	28-11239-11	7-18	-
28-11203-1	7-14	160	28-11239-13	7-18	-
28-11204-1	7-14	170	28-11239-19	7-18	-
28-11204-11	7-14	170	28-11239-21	7-18	-
28-11205-1	7-14	180	28-11239-21	7-18	-
28-11205-11	7-14	180	28-11239-23	7-18	-
28-11206-1	7-14	210	28-11239-25	7-18	-
28-11206-5	7-14	210	28-11239-27	7-18	-
28-11207-1	7-14	220	28-11239-27	7-18	-
28-11207-3	7-14	220	28-11239-3	7-18	20
28-11215-1	7-15	200	28-11239-35	7-18	-
28-11215-1	7-16	120	28-11239-35	7-18	-
28-11217-1	7-15	160	28-11239-37	7-18	-
28-11217-1	7-16	100	28-11239-37	7-18	-

ENSTROM F-28/280 SERIES ILLUSTRATED PARTS CATALOG

PART NUMBER INDEX SECTIONS 3 THROUGH 7 AND 9 THROUGH 12 FIGURES 8-1 THROUGH 8-11

Part Number	Figure	Item	Part Number	Figure	Item
28-11239-39	7-18	-	28-113080-4	7-4	-630
28-11239-39	7-18	-	28-113080-5	7-4	620
28-11239-9	7-18	30	28-113080-6	7-4	-630
28-11242-11	7-14	140	28-113084-11	7-4	450
28-11243-11	7-14	130	28-113085-13	7-4	430
28-11248-1	7-14	-	28-113085-14	7-4	-440
28-11298-13	3-12	10	28-113087-11	7-4	250
28-11300	7-1	-	28-113088-11	7-4	300
28-11300	7-13	-	28-113090-11	7-4	310
28-11300-1	7-1	-	28-113090-12	7-4	-320
28-11303-1	9-1	1	28-113090-13	7-4	-340
28-11303-4	9-1	12	28-113090-14	7-4	-350
28-11303-5	9-1	1A	28-113090-15	7-4	410
28-113040-11	9-1	2	28-113090-16	7-4	-420
28-113040-13	9-1	2A	28-113090-17	7-4	470
28-113041-11	7-5	-250	28-113090-18	7-4	640
28-113041-12	7-5	260	28-113090-19	7-4	490
28-113042-11	9-1	9	28-113090-20	7-4	-500
28-113046-3	7-5	990	28-113090-21	7-4	30
28-113046-4	7-5	-1000	28-113090-22	7-4	-40
28-113047-11	7-5	-230	28-113090-23	7-4	-
28-113047-12	7-5	240	28-113090-24	7-4	-
28-113048-2	7-1	-	28-113090-25	7-4	270
28-113048-2	7-2	-	28-113090-27	7-4	590
28-113052-2	7-2	30	28-113090-3	7-4	-
28-113054-1	6-5	250	28-113090-4	7-4	-
28-113054-1	7-7	10	28-11309-1	7-1	-
28-113054-12	7-7	20	28-113091-1	7-4	-540
28-113055-1	7-7	-	28-113091-3	7-4	-540
28-113069-1	9-1	14	28-113091-3CS	7-4	-540A
28-113071-1	7-1	-	28-113091-5	7-4	520
28-113076-1	7-4	210	28-113091-6	7-4	-530
28-113076-15	7-4	-	28-113092-11	7-4	550
28-113077-11	7-4	270	28-113092-13	7-4	550
28-113078-11	7-4	240	28-11309-3	7-1	600
28-11307-901	8-5	560	28-11309-3	7-2	170
28-11307-902	8-5	-550	28-113093-13	7-4	670
28-113080-3	7-4	620	28-11309-4	7-1	610

ENSTROM F-28/280 SERIES ILLUSTRATED PARTS CATALOG

PART NUMBER INDEX SECTIONS 3 THROUGH 7 AND 9 THROUGH 12 FIGURES 8-1 THROUGH 8-11

Part Number	Figure	Item	Part Number	Figure	Item
28-11309-4	7-2	-180	28-113113-11	7-6	370
28-11309-6	7-1	620	28-113113-13	7-6	310
28-113096-1	7-4	430	28-113114-1	7-6	200
28-113096-2	7-4	-440	28-113114-2	7-6	-210
28-11309-7	7-1	630	28-113118-11	7-6	220
28-113097-13	7-4	-	28-113118-12	7-6	-230
28-113097-14	7-4	-	28-113120-11	7-6	400
28-113097-3	7-4	560	28-113122-1	7-6	150
28-113097-4	7-4	-570	28-113122-2	7-6	-160
28-11310-1	7-1	-10	28-113122-3	7-6	170
28-11310-10	7-4	20	28-113122-4	7-6	-180
28-11310-103	7-2	40	28-113124-11	7-6	580
28-11310-104	7-2	-50	28-113124-12	7-6	-590
28-113101-1	7-6	500	28-113125-11	7-6	560
28-11310-11	7-1	50	28-113125-12	7-6	-570
28-113101-2	7-6	-510	28-113128-11	7-6	660
28-113101-3	7-6	380	28-113129-11	7-6	640
28-113101-4	7-6	-390	28-113134-11	7-6	600
28-11310-2	7-1	20	28-113134-12	7-6	-610
28-113102-1	7-5	-	28-113135-11	7-6	320
28-113102-11	7-5	790	28-113135-12	7-6	-330
28-113103-1	7-6	540	28-113136-11	7-6	340
28-113103-2	7-6	-550	28-113136-12	7-6	-350
28-113103-3	7-6	480	28-113139-1	7-6	10
28-113103-4	7-6	-490	28-113139-2	7-6	-20
28-11310-5	7-4	-40	28-113140-1	7-6	430
28-11310-6	7-4	30	28-11360-1	6-9	70
28-11310-7	7-1	30	28-11371-1	7-1	-
28-113107-11	3-11	-	28-11371-1	7-1	810
28-113107-13	3-11	-	28-11371-1	7-4	610
28-113107-15	3-11	-	28-11372-1	7-1	290
28-11310-8	7-1	-40	28-11373-1	7-1	270
28-113108-11	3-11	-	28-11376-1	7-1	260
28-113108-13	3-11	-	28-11392-1	12-5	130
28-113108-15	3-11	-	28-11395-1	9-2	5
28-11310-905	7-1	100	28-11395-1	9-3	50
28-113112-11	7-6	410	28-11395-1	9-4	50
28-113112-12	7-6	-420	28-11400-1	7-1	-

ENSTROM F-28/280 SERIES ILLUSTRATED PARTS CATALOG

PART NUMBER INDEX SECTIONS 3 THROUGH 7 AND 9 THROUGH 12 FIGURES 8-1 THROUGH 8-11

Part Number	Figure	Item	Part Number	Figure	Item
28-11400-1	7-8	-	28-114017-1	7-10	130
28-114002-3	7-11	-230	28-114017-1	7-11	200
28-114003-1	7-11	400	28-114018-1	7-10	160
28-114003-3	7-11	400	28-114018-1	7-11	220
28-114010-11	7-11	50	28-114019-11	7-11	-110
28-114010-12	7-11	-60	28-114019-11	7-12	80
28-114011-13	7-11	-160	28-114019-13	7-11	-130
28-114011-15	7-11	-170	28-114019-15	7-12	70
28-114011-17	7-11	-150	28-114019-3	7-10	10
28-114011-5	7-10	110	28-114019-3	7-11	-100
28-114011-5	7-11	140	28-114019-3	7-12	-
28-114012-1	7-10	200	28-114019-5	7-10	80
28-114012-11	7-11	240	28-11402-1	7-8	20
28-11401-3	7-8	10	28-11402-1	7-9	30
28-11401-3	7-11	-90	28-11402-1	7-11	480
28-114013-11	7-11	-280	28-114022-1	7-10	50
28-114013-12	7-11	-290	28-114022-1	7-12	60
28-114013-13	7-11	-300	28-114023-11	7-10	20
28-114013-17	7-11	-280	28-114023-11	7-12	10
28-114013-3	7-10	180	28-114024-1	7-10	30
28-114013-3	7-11	270	28-114024-1	7-12	-
28-114014-1	7-11	-	28-114024-11	7-12	20
28-114014-3	7-11	-	28-114024-12	7-12	-30
28-114014-5	7-10	-	28-114025-1	7-11	-120
28-114014-5	7-11	-	28-114026-3	7-10	40
28-114014-5	7-12	-	28-114026-3	7-12	90
28-114014-7	7-11	-	28-11403-1	7-8	160
28-114014-9	7-10	-	28-11404-1	9-2	11
28-114014-9	7-11	-	28-11404-13	9-3	290
28-114015-1	7-10	120	28-11404-13	9-4	230
28-114015-1	7-11	10	28-11405-1	7-8	-270
28-114015-2	7-10	170	28-11405-2	7-8	280
28-114015-2	7-11	30	28-11407-1	7-1	340
28-114016-1	7-11	310	28-11407-5	7-4	170
28-114016-3	7-11	-320	28-11408-10	7-1	400
28-114016-7	3-5A	160	28-11408-2	7-1	360
28-114016-7	7-10	250	28-11409-1	7-8	310
28-114016-7	7-11	310	28-11412-3	7-1	170

ENSTROM F-28/280 SERIES ILLUSTRATED PARTS CATALOG

PART NUMBER INDEX SECTIONS 3 THROUGH 7 AND 9 THROUGH 12 FIGURES 8-1 THROUGH 8-11

Part Number	Figure	Item	Part Number	Figure	Item
28-11412-4	7-1	-175	28-11435-1	7-1	180
28-11413-10	7-8	-90A	28-11435-1	7-4	390
28-11413-11	7-8	100	28-11436	7-1	110
28-11413-12	7-8	-100A	28-11437-1	7-1	380
28-11413-13	7-8	-100B	28-11438-1	7-1	390
28-11413-3	7-8	-70	28-11440-1	7-1	490
28-11413-4	7-8	80	28-11442-1	7-8	200
28-11413-5	7-10	310	28-114501-1	7-11	-70
28-11413-6	7-10	-320	28-114509	7-11	-80
28-11413-9	7-8	90	28-11452	10-1	22
28-11414-1	7-1	-	28-11460-1	7-10	330
28-11414-2	7-1	-	28-11460-3	7-9	80
28-11414-3	7-1	-460	28-11461-1	9-5	100
28-11414-4	7-1	450	28-11462-11	9-5	95
28-11414-5	7-1	-480	28-11464-1	9-5	75
28-11414-6	7-1	470	28-11466-1	9-5	70
28-11417-1	7-1	120	28-11468-2	9-5	35
28-11418-1	7-1	-	28-11484-11	7-4	580
28-11418-2	7-1	-	28-11484-13	7-4	380
28-11420-1	7-8	60	28-11500-1	3-17	-
28-11425-10	7-1	770	28-11500-5	3-17	50
28-11425-2	7-1	-	28-11501-1	3-16	-
28-11425-2	7-2	-	28-11501-10	3-16	20
28-11425-3	7-1	720	28-11501-12	3-16	10
28-11425-3	7-2	10	28-11501-15	3-16	10
28-11425-4	7-1	710	28-11501-17	3-16	10
28-11425-4	7-2	-20	28-11501-3	3-16	-
28-11425-5	7-1	760	28-11501-3	3-17	10
28-11425-5	7-2	-70	28-11501-4	3-16	40
28-11425-6	7-1	750	28-11501-4	3-17	170
28-11425-6	7-2	60	28-11501-901	3-16	50
28-11425-7	7-1	740	28-11502-5	3-16	60
28-11425-8	7-1	730	28-11504-1	9-2	43
28-11425-9	7-1	780	28-11600-13	9-2	1
28-11427-1	7-1	220	28-11600-17	9-2	2
28-11428-1	7-1	310	28-11600-19	9-2	28
28-11430-1	9-1	11	28-11600-20	9-1	26
28-11431-1	9-1	13	28-11600-21	9-1	27

ENSTROM F-28/280 SERIES ILLUSTRATED PARTS CATALOG

PART NUMBER INDEX SECTIONS 3 THROUGH 7 AND 9 THROUGH 12 FIGURES 8-1 THROUGH 8-11

Part Number	Figure	Item	Part Number	Figure	Item
28-116002-13	6-11	140	28-11622-1	9-4	20
28-116002-15	6-11	140	28-11622-13	9-3	21
28-11600-3	9-1	17	28-11622-15	9-4	20A
28-11600-4	9-1	18	28-11622-17	9-3	21A
28-116004-3	9-1	20	28-11622-21	9-4	20A
28-11600-5	9-1	16	28-11623-1	9-4	–
28-116005-1	9-1	21	28-11623-2	9-4	–
28-11600-6	9-2	2A	28-11624	9-4	–
28-116006-1	9-1	22	28-11625-11	9-4	160
28-11600-7	9-2	1A	28-11625-13	9-3	420
28-116007-1	9-1	23	28-11626	9-3	–
28-11600-8	9-1	19	28-11700	7-1	–
28-116008-1	9-1	24	28-11701-1	7-1	830
28-11600-9	9-2	28A	28-11702-1	7-1	840
28-116009-1	9-1	25	28-11702-2	7-1	–845
28-11603-1	9-2	3	28-11703-1	7-1	850
28-11607-11	7-2	–90	28-11703-2	7-1	–855
28-11607-12	7-2	80	28-11708-1	7-1	–
28-11608-11	9-3	30	28-11708-1	7-3	30
28-11608-11	9-4	30	28-11708-2	7-1	–
28-11608-13	9-3	30	28-11708-2	7-3	–40
28-11608-13	9-4	30	28-11709-1	7-1	–
28-11610-3	9-3	–	28-11709-2	7-1	–
28-11610-5	9-3	–	28-11709-3	7-3	140
28-11611-1	9-3	440	28-11709-4	7-3	–150
28-11611-2	9-3	430	28-11710-1	7-1	690
28-11612-11	9-3	–	28-11710-1	7-3	110
28-11613-11	9-3	460	28-11710-11	7-1	690
28-11613-12	9-3	450	28-11710-11	7-3	110
28-11614-11	9-3	480	28-11710-12	7-1	–695
28-11614-12	9-3	470	28-11710-12	7-3	–120
28-11615-13	9-3	490	28-11710-2	7-1	–695
28-11615-15	9-3	490	28-11710-2	7-3	–120
28-11618-11	9-3	510	28-11711-11	7-1	–
28-11618-12	9-3	500	28-11711-11	7-3	10
28-11620-1	9-4	130	28-11711-12	7-1	–
28-11621-11	9-4	170	28-11711-12	7-3	–20
28-11621-13	9-4	180	28-11711-17	7-1	–

ENSTROM F-28/280 SERIES ILLUSTRATED PARTS CATALOG

PART NUMBER INDEX SECTIONS 3 THROUGH 7 AND 9 THROUGH 12 FIGURES 8-1 THROUGH 8-11

Part Number	Figure	Item	Part Number	Figure	Item
28-11711-17	7-3	10	28-12112-5	3-9	10
28-11711-18	7-1	-	28-12116-11	3-9	50
28-11711-18	7-3	-20	28-12118-2	3-9	10
28-11712-11	7-1	-	28-12122-1	3-9	20
28-11712-11	7-3	160	28-12125-1	3-9	30
28-11712-15	7-3	160	28-12127-11	3-9	80
28-11713-11	7-4	90	28-12133-11	3-23	630
28-11713-12	7-4	-100	28-12134-13	3-8	20
28-11713-15	7-4	120	28-12134-15	3-8	20
28-11714-3	7-3	-	28-12134-991	3-8	-
28-11714-4	7-3	-	28-12140-1	3-5	20
28-11715-11	7-4	20	28-12141-11	3-30	20A
28-11715-11	7-5	-	28-12142-1	3-22	60
28-121000-19	3-3	330	28-12145-1	3-5	10
28-121000-19	3-5	100	28-12146-1	3-22	450
28-121000-901	3-7	-	28-12146-1	3-23	450
28-12100-10	3-22	320	28-12149-1	3-20	40
28-121001-1	3-9	30	28-12149-1	3-20A	40
28-12100-12	3-22	450	28-12149-1	3-20B	40
28-12100-13	11-10	60	28-12150-1	3-7	350
28-121005-19	3-8	30	28-12151-1	3-7	300
28-12100-6	11-10	110	28-12155-1	3-8	60
28-12100-7	11-10	10	28-12155-15	3-8	65
28-121007-1	3-4	210	28-12158-11	3-7	370
28-12100-8	3-22	60	28-12160-11	3-7	340
28-121008-1	3-4	230	28-12162-1	3-3	250
28-121008-3	3-4	230	28-123005-5	3-4	70
28-12100-9	11-10	20	28-123007-1	3-3	70
28-12100-903	3-6	40	28-123007-11	3-3	70
28-12100-904	3-6	30	28-123009-11	3-3	80
28-121009-3	3-8	90	28-123009-13	3-3	90
28-121011-1	3-8	130	28-123009-15	3-3	90
28-12101-11	3-22	190	28-123009-17	3-3	80
28-121011-3	3-8	10	28-12301-1	3-1	20
28-121012-11	3-8	40	28-123011-1	3-4	160
28-121013-1	3-7	20	28-123012-1	3-4	130
28-121014-1	3-7	30	28-123013-1	3-4	110
28-12112-4	3-9	10	28-123014-1	3-4	20

ENSTROM F-28/280 SERIES ILLUSTRATED PARTS CATALOG

PART NUMBER INDEX SECTIONS 3 THROUGH 7 AND 9 THROUGH 12 FIGURES 8-1 THROUGH 8-11

Part Number	Figure	Item	Part Number	Figure	Item
28-123015-1	3-4	10	28-12400-12	3-24	260
28-123016-1	3-4	200	28-12400-12	11-13	160
28-123017-1	3-7	100	28-12400-16	3-24	50
28-123018-1	3-23	210	28-124002-3	3-23	61
28-123019-1	3-2	280	28-12400-23	3-22	40
28-123019-1	3-3	40	28-12400-23	3-23	40
28-12302-1	3-1	10	28-124003-1	3-4	180
28-123022-11	3-3	10	28-124003-13	3-23	430
28-123024-1	3-4	150	28-124003-19	3-23	–
28-12305	10-1	13	28-124003-5	3-8	70
28-12305	10-1	2	28-124005-1	3-23	484
28-12305	10-2	14	28-124006-11	3-23	150
28-12305	10-2	2	28-12400-910	3-23	330
28-12305-1	3-18	40	28-12400-919	3-24	90
28-12305-1	7-9	240	28-12401-1	3-24	10
28-12313-1	3-1	150	28-12401-2	3-24	20
28-12329-1	3-1	120	28-12408-1	3-25	40
28-12329-1	3-2	280	28-12409-1	3-25	30
28-12335-1	3-2	40	28-12410-1	3-25	100
28-12341-1	3-2	90	28-12411-3	3-25	80
28-12344-11	3-2	–	28-12415-9	3-2	130
28-12345-1	3-2	–	28-12416-3	3-24	480
28-12350-1	3-2	110	28-12416-3	11-21	220
28-12350-2	3-2	110	28-12416-4	3-24	470
28-12350-3	3-2	110	28-12417-1	3-26	160
28-12350-5	3-2	110	28-12417-11	3-26	160
28-12353-1	3-2	70	28-12418-1	3-24	500
28-12354-1	3-2	20	28-12419-1	3-24	520
28-12354-2	3-2	20	28-12420-11	3-24	580
28-12357-1	3-1	100	28-12420-11	11-21	230
28-12357-1	3-2	50	28-12420-13	3-24	570
28-12358-1	3-2	200	28-12420-13	11-21	240
28-12359-11	3-3	–	28-12420-15	3-24	560
28-12359-13	3-3	–	28-12420-15	11-21	250
28-12360-1	3-3	190	28-12421-1	3-24	–
28-12361-1	3-2	10	28-12422-1	3-24	30
28-12362-1	3-2	–	28-12424-1	3-24	610
28-12362-1	3-2	100	28-12424-1	11-21	260

ENSTROM F-28/280 SERIES ILLUSTRATED PARTS CATALOG

PART NUMBER INDEX SECTIONS 3 THROUGH 7 AND 9 THROUGH 12 FIGURES 8-1 THROUGH 8-11

Part Number	Figure	Item	Part Number	Figure	Item
28-12425-1	11-21	270	28-12462-3	3-23	590
28-12426-1	11-21	280	28-12463-1	3-23	480
28-12427-1	11-21	290	28-12464-3	3-23	60
28-12428-1	11-21	300	28-12465-1	3-24	620
28-12429-3	3-24	11	28-12470-11	11-8	335
28-12429-4	3-24	21	28-12470-11	11-9	265
28-12433-1	3-24	600	28-12470-11	11-15	–
28-12433-1	11-21	310	28-12470-11	11-15	–
28-12433-1	11-21	70	28-12470-11	11-7	710
28-12433-13	11-21	320	28-12471-11	11-8	445
28-12433-2	3-24	600	28-12471-11	11-9	350
28-12433-2	11-21	310	28-12471-11	11-15	–
28-12433-21	11-21	80	28-12471-11	11-7	940
28-12436-1	3-24	400	28-12472-11	11-8	345
28-12436-1	3-24	410	28-12472-11	11-9	275
28-12437-1	3-24	420	28-12472-11	11-15	–
28-12437-3	3-24	420	28-12472-11	11-7	700
28-12438-1	3-24	210	28-12473-11	11-8	435
28-12438-3	3-24	210	28-12473-11	11-9	345
28-12439-1	3-24	330	28-12473-11	11-15	–
28-12440-1	3-24	110	28-12473-11	11-15	–
28-12441-1	3-24	390	28-12473-11	11-7	920
28-12441-3	3-24	390	28-12474-11	11-8	450
28-12450-11	3-24	590	28-12474-11	11-9	360
28-12450-11	11-21	330	28-12474-11	11-15	–
28-12450-13	3-24	590	28-12474-11	11-7	960
28-12450-13	11-21	340	28-12475-11	11-8	440
28-12451-1	3-24	370	28-12475-11	11-9	355
28-12452-1	3-24	290	28-12475-11	11-15	–
28-12453-1	3-24	280	28-12475-11	11-7	930
28-12456-1	3-24	400	28-12478-11	3-24	630
28-12457-1	3-24	410	28-12479-11	11-21	90
28-12458-1	3-24	330	28-12480-1	3-23	540
28-12459-1	3-24	370	28-125000-11	3-28	–
28-12460-1	3-24	340	28-12500-1	3-27	–
28-12461-1	3-23	340	28-125007	10-1	1
28-12461-3	3-23	600	28-125007	10-2	1
28-12462-1	3-23	230	28-125008-1	3-8	160

ENSTROM F-28/280 SERIES ILLUSTRATED PARTS CATALOG

PART NUMBER INDEX SECTIONS 3 THROUGH 7 AND 9 THROUGH 12 FIGURES 8-1 THROUGH 8-11

Part Number	Figure	Item	Part Number	Figure	Item
28-125011-1	3-29	10	28-12600-4	3-18	80
28-125011-31	3-29	40	28-12600-4	3-19	160
28-125011-33	3-29	50	28-126004-1	3-19	10
28-125011-49	3-29	50	28-126004-11	3-19	–
28-125011-5	3-29	30	28-126005-1	3-19	50
28-125016-11	3-28	–	28-126006-1	3-19	20
28-125017-1	3-28	180	28-126007-17	3-20	240
28-125082-1	3-29	20	28-126007-3	3-20	240
28-125082-3	3-29	20	28-126007-3	3-20A	240
28-125082-3	3-8	–	28-126007-3	3-20B	240
28-12551-13	3-28	270A	28-126007-5	3-20	220
28-12551-15	3-28	270	28-126007-5	3-20A	220
28-12551-17	3-28	270	28-126007-5	3-20B	220
28-12551-19	3-28	270	28-126007-7	3-20	220
28-12551-21	3-28	270	28-126008-1	3-20	330
28-12551-21	3-28	270	28-126008-1	3-20A	330
28-12552-3	3-28	190	28-126008-1	3-20B	330
28-12552-5	3-28	190	28-126008-3	3-20	330
28-12554-101	3-28	231B	28-126008-3	3-20A	330
28-12554-103	3-28	231A	28-126008-3	3-20B	330
28-12554-7	3-28	231D	28-12601-1	3-21	10
28-12554-9	3-28	231C	28-12603-1	3-21	–
28-12555-1	3-28	240A	28-12603-3	3-21	–
28-12555-7	3-28	240	28-12603-4	3-21	–
28-12555-7	3-28	240	28-12605-1	3-21	–
28-12555-7	3-28	240	28-12607-101	3-20	230
28-12555-7	3-28	240	28-12607-13	3-20	250
28-12560-1	3-28	260	28-12607-6	3-20	250
28-12560-1	3-28	260	28-12607-6	3-20A	250
28-12560-1	3-28	260	28-12607-6	3-20B	250
28-12560-1	3-28	260	28-12607-8	3-20	230
28-12570-3	3-28	370	28-12607-8	3-20A	230
28-12574-11	3-28	210	28-12607-8	3-20B	230
28-12575-1	3-3	160	28-12608-1	3-18	100
28-12575-1	3-3	340	28-12608-3	3-18	–
28-12576-1	3-3	280	28-12608-4	3-18	–
28-12577-1	3-28	130	28-12608-4	3-20	–
28-12577-1	3-3	–	28-12608-4	3-20A	–

ENSTROM F-28/280 SERIES ILLUSTRATED PARTS CATALOG

PART NUMBER INDEX SECTIONS 3 THROUGH 7 AND 9 THROUGH 12 FIGURES 8-1 THROUGH 8-11

Part Number	Figure	Item	Part Number	Figure	Item
28-12608-4	3-20B	–	28-12616-1	3-20A	280
28-12609-1	3-18	90	28-12616-1	3-20B	280
28-12609-3	3-18	90	28-12617-1	3-20	320
28-12609-3	3-20	310	28-12617-1	3-20A	320
28-12609-3	3-20A	310	28-12617-1	3-20B	320
28-12609-3	3-20B	310	28-12618-1	3-6	220
28-12610-12	3-20	170	28-12618-1	3-7	190
28-12610-12	3-20A	170	28-12618-13	3-7	200
28-12610-12	3-20B	170	28-12618-5	3-6	220
28-12610-13	3-20	180	28-12618-5	3-7	190
28-12610-13	3-20A	180	28-12619-1	3-20	480
28-12610-13	3-20B	180	28-12619-1	3-20A	480
28-12610-3	3-20	10	28-12619-1	3-20B	480
28-12610-3A	3-20	–	28-12619-4	3-20	–
28-12610-3A	3-20A	–	28-12619-4	3-20A	–
28-12611-1	3-18	20	28-12619-4	3-20B	–
28-12611-4	3-18	60	28-12619-5	3-20	–
28-12611-5	3-18	30	28-12619-5	3-20A	–
28-12611-5	3-19	–	28-12619-5	3-20B	–
28-12611-5	3-20	150	28-12620-1	3-20	190
28-12611-5	3-20A	150	28-12620-1	3-20A	190
28-12611-5	3-20B	150	28-12620-1	3-20B	190
28-12611-8	3-18	50	28-12621-1	3-18	–
28-12612-1	3-18	70	28-12621-1	3-20	–
28-12613-1	3-18	10	28-12621-1	3-20A	–
28-12613-4	3-20	270	28-12621-1	3-20B	–
28-12613-4	3-20A	270	28-12623-1	3-6	180
28-12613-4	3-20B	270	28-12624-1	3-6	210
28-12613-5	3-20	260	28-12624-1	3-7	200
28-12613-5	3-20A	260	28-12625-1	3-6	190
28-12613-5	3-20B	260	28-12626-1	3-6	200
28-12614-1	3-20	290	28-12626-1	3-7	270
28-12614-1	3-20A	290	28-12626-13	3-6	200
28-12614-1	3-20B	290	28-12626-13	3-7	270
28-12615-1	3-20	300	28-12628-11	3-20	290
28-12615-1	3-20A	300	28-12629-11	3-20	280
28-12615-1	3-20B	300	28-12642-1	3-21	–
28-12616-1	3-20	280	28-12644-1	3-21	–

ENSTROM F-28/280 SERIES ILLUSTRATED PARTS CATALOG

PART NUMBER INDEX SECTIONS 3 THROUGH 7 AND 9 THROUGH 12 FIGURES 8-1 THROUGH 8-11

Part Number	Figure	Item	Part Number	Figure	Item
28-12645-1	3-20B	200	28-12655-5	3-20	50
28-12646-11	3-20A	–	28-12655-5	3-20A	50
28-12646-11	3-20B	–	28-12656-1	3-20B	30
28-12646-13	3-20	–	28-12656-3	3-20	30
28-12646-13	3-20A	–	28-12656-3	3-20A	30
28-12646-13	3-20B	–	28-12658-11	3-20B	–
28-12646-15	3-20	–	28-12659-1	3-20	130
28-12646-15	3-20A	–	28-12659-13	3-20B	–
28-12646-15	3-20B	–	28-12659-15	3-20	130
28-12646-17	3-20	–	28-12659-15	3-20A	130
28-12646-17	3-20A	–	28-12659-16	3-20A	140
28-12646-17	3-20B	–	28-12659-17	3-20	140
28-12646-21	3-20	–	28-12659-17	3-20A	140
28-12647-1	3-20A	200	28-12662-1	3-20	60
28-12647-1	3-20B	200	28-12662-1	3-20A	60
28-12647-3	3-20	200	28-12662-11	3-20B	60
28-12648-1	3-19	70	28-12662-13	3-20A	60
28-12649-1	3-19	60	28-12662-13	3-20B	60
28-12650-1	3-20	–	28-12663-11	3-20B	–
28-12650-1	3-20B	–	28-12664-11	3-7	240
28-12650-11	3-20B	–	28-12666-1	3-20B	–
28-12650-17	3-20B	–	28-12666-1	3-20B	110
28-12651-11	3-20B	–	28-12666-3	3-20	110
28-12651-13	3-20	–	28-12666-3	3-20A	110
28-12651-13	3-20A	–	28-12666-3	3-20B	110
28-12651-13	3-20B	–	28-12667-11	3-20	–
28-12652-13	3-20	–	28-12667-11	3-20B	–
28-12652-13	3-20A	–	28-12667-13	3-20B	–
28-12652-5	3-20	–	28-12668-11	3-20	–
28-12652-5	3-20	–	28-12668-11	3-20A	–
28-12653-13	3-20	–	28-12668-11	3-20B	–
28-12653-13	3-20A	–	28-12668-13	3-20B	–
28-12653-5	3-20	–	28-12669-11	3-20B	–
28-12654-11	3-7	220	28-12674-1	3-20B	70
28-12654-13	3-7	230	28-12675-1	3-20B	10
28-12655-1	3-20B	50	28-12675-3	3-20A	10
28-12655-3	3-20A	50	28-12676-1	3-20B	–
28-12655-3	3-20B	50	28-12676-3	3-20B	–

ENSTROM F-28/280 SERIES ILLUSTRATED PARTS CATALOG

PART NUMBER INDEX SECTIONS 3 THROUGH 7 AND 9 THROUGH 12 FIGURES 8-1 THROUGH 8-11

Part Number	Figure	Item	Part Number	Figure	Item
28-12676-5	3-20B	–	28-12687-1	3-20A	120
28-12676-7	3-20A	–	28-12687-1	3-20B	120
28-12676-9	3-20A	–	28-12688-1	3-20A	70
28-12676-901	3-20	–	28-12688-13	3-20A	–
28-12677-1	3-20B	160	28-12688-15	3-20A	–
28-12677-3	3-20B	160	28-12688-17	3-20A	–
28-12678-11	3-20B	–	28-12688-19	3-20A	–
28-12679-1	3-20B	130	28-12688-25	3-20A	–
28-12679-3	3-20B	130	28-12688-29	3-20	–
28-12681-1	3-20B	80	28-12688-29	3-20A	–
28-12681-3	3-20B	80	28-12688-3	3-20A	70
28-12681-5	3-20	80	28-12688-5	3-20	70
28-12681-5	3-20A	80	28-12688-5	3-20A	70
28-12682-11	3-20	90	28-12689-11	3-20	160
28-12682-11	3-20A	90	28-12689-11	3-20A	160
28-12682-11	3-20B	90	28-127000-1	10-1	–
28-12682-13	3-20B	–	28-127000-11	10-1	3
28-12683-1	3-20	100	28-127000-11	10-2	3
28-12683-1	3-20A	100	28-127001	10-2	–
28-12683-1	3-20B	100	28-127002-1	10-4	–
28-12683-11	3-20	–	28-127002-3	10-3	–
28-12683-11	3-20A	–	28-127002-5	10-4	–
28-12683-11	3-20B	–	28-12701-3	10-1	15
28-12683-13	3-20	–	28-12701-4	10-1	12
28-12683-13	3-20A	–	28-12701-4	10-2	13
28-12683-13	3-20B	–	28-12701-5	10-1	5
28-12683-13	3-20B	–	28-12701-5	10-2	5
28-12683-15	3-20B	–	28-12705	10-1	16
28-12683-3	3-20B	–	28-12705	10-3	19
28-12683-3	3-20B	100	28-12706	10-1	14
28-12684-11	3-20B	–	28-12706	10-2	15
28-12684-11	3-20B	–	28-12706-1	7-9	230
28-12685-11	3-20B	–	28-12706-11	3-5A	10
28-12685-13	3-20B	–	28-12706-11	7-9	230
28-12686-11	3-20	490	28-12714	10-1	9
28-12686-11	3-20A	490	28-12714	10-2	10
28-12686-11	3-20B	490	28-12718	10-1	10
28-12687-1	3-20	120	28-12718	10-2	11

ENSTROM F-28/280 SERIES ILLUSTRATED PARTS CATALOG

PART NUMBER INDEX SECTIONS 3 THROUGH 7 AND 9 THROUGH 12 FIGURES 8-1 THROUGH 8-11

Part Number	Figure	Item	Part Number	Figure	Item
28-12719	8-5	–	28-13117-9	5-7	40
28-12719-11	8-5	590	28-13120-1	5-6	150
28-12719-12	8-5	–600	28-13122-1	5-7	10
28-127502-1	10-4	340	28-13122-991	5-7	–
28-127508-1	10-3	10	28-13129-13	5-4	280
28-127508-1	10-4	280	28-13134-5	5-6	180
28-127509-1	10-3	5	28-13137-1	5-6	60
28-127509-1	10-4	120	28-13137-11	5-6	60
28-127510-1	10-3	3	28-13142-1	5-4	180
28-127510-1	10-4	100	28-13145-1	12-1	–190
28-127520-11	10-3	2	28-13145-1	4-4	300
28-127520-11	10-4	20	28-13148-1	5-6	70
28-127520-13	10-3	1	28-13149-1	5-6	80
28-127520-13	10-4	10	28-13170-103	5-6	10
28-127520-15	10-4	30	28-13170-3-R	5-6	10
28-127520-17	10-2	25	28-13170-7-R	5-6	10
28-127520-17	10-4	360	28-13170-900	5-6	10
28-127520-19	10-2	26	28-13170-903	5-4	240
28-127520-19	10-4	350	28-13170-905	5-4	–
28-127520-25	10-3	16	28-13170-909	5-6	10
28-127520-29	10-4	10	28-13170-9-R	5-6	10
28-127521-11	10-3	11	28-13177-1	5-6	100
28-127521-11	10-4	290	28-13180-11	5-4	270
28-127523-1	10-4	120	28-13181-11	5-4	300
28-127524-1	10-4	280	28-13182-1	5-4	330
28-12816-1	11-21	350	28-13182-11	5-4	330
28-12830-11	11-21	100	28-13184-11	5-4	350
28-12830-11	7-5	170	28-132001-11	5-4	100
28-13005-1	5-6	260	28-132001-13	5-4	100
28-13101-1-R	5-6	10	28-132005-1	5-3	–
28-13101-5-R	5-6	10	28-132005-11	5-3	490
28-13107-13	5-6	210	28-132005-3	5-3	–
28-13107-15	5-6	210	28-132006-11	5-3	530
28-13117-4	5-7	20	28-132008-11	5-3	380
28-13117-5	5-7	30	28-132009-11	5-3	540
28-13117-6	5-7	45	28-132010-13	5-4	100
28-13117-7	5-7	50	28-132020-901	5-1	–
28-13117-8	5-7	35	28-132020-903	5-3	–

ENSTROM F-28/280 SERIES ILLUSTRATED PARTS CATALOG

PART NUMBER INDEX SECTIONS 3 THROUGH 7 AND 9 THROUGH 12 FIGURES 8-1 THROUGH 8-11

Part Number	Figure	Item	Part Number	Figure	Item
28-132020-904	5-3	–	28-13263-1	5-2	150
28-132022-1	5-1	–	28-13264-1	5-1	80
28-132022-11	5-1	330	28-13265-1	5-1	100
28-132022-2	6-11	200	28-13266-1	5-1	160
28-132022-3	6-11	200	28-13266-15	5-1	200
28-13210-13	5-4	110	28-13267-1	5-1	190
28-13211-1	5-4	70	28-13267-11	5-1	210
28-13212-1	5-4	30	28-13268-1	5-1	30
28-13215-1	5-4	250	28-13269-1	5-1	140
28-13215-3	5-4	250	28-13271-1	5-4	190
28-13227-5	5-4	10	28-13273-1	5-4	100
28-13229-1	5-3	10	28-13273-13	5-4	100
28-13230-1	5-3	20	28-13274-1	5-1	180
28-13231-3	5-4	170	28-13276-1	5-5	320
28-13231-4	5-4	170	28-13277-1	5-1	40
28-13231-5	5-4	170	28-13278-1	5-3	310
28-13231-6	5-4	170	28-13279-1	5-2	120
28-13231-7	3-21	60	28-13280-3	5-1	230
28-13231-7	5-4	170	28-13280-4	5-1	240
28-13232-1	5-6	40	28-13281-3	5-4	420
28-13233-1	5-3	70	28-13281-4	5-4	420
28-13234-1	5-3	80	28-13281-5	5-4	420
28-13238-1	5-3	110	28-13282-3	5-3	290
28-13238-1	5-6	30	28-13282-4	5-3	290
28-13245-901	5-3	230	28-13282-5	5-3	290
28-13246-1	5-3	260	28-13283-1	5-1	90
28-13248-1	5-3	250	28-13284-1	5-1	430
28-13250-1	5-2	20	28-13285-4	5-5	340
28-13250-11	5-2	20	28-13285-5	5-1	250
28-13251-1	5-2	30	28-13285-6	5-1	50
28-13252-1	5-2	80	28-13285-7	5-1	170
28-13253-1	5-2	10	28-13292-1	5-3	50
28-13254-1	5-2	40	28-13292-4	5-3	60
28-13255-1	5-2	130	28-13296-1	5-3	280
28-13256-1	5-2	70	28-13297-1	5-3	240
28-13259-4	5-1	60	28-13299-1	5-3	420
28-13259-4	5-2	–	28-13299-3	5-3	420
28-13260-1	5-1	380	28-13300-13	5-4	100

ENSTROM F-28/280 SERIES ILLUSTRATED PARTS CATALOG

PART NUMBER INDEX SECTIONS 3 THROUGH 7 AND 9 THROUGH 12 FIGURES 8-1 THROUGH 8-11

Part Number	Figure	Item	Part Number	Figure	Item
28-13302-1	5-4	430	28-13605-5	7-5	-440A
28-13302-11	5-4	430	28-13605-6	12-3	60
28-13302-13	5-4	430	28-13605-6	7-5	-440B
28-13303-11	5-4	300	28-13605-7	12-3	60
28-13305-1	5-4	40	28-13605-7	7-5	-440C
28-13306-1	5-4	150	28-13605-8	12-3	60
28-13313-1	5-3	140	28-13605-8	7-5	-440D
28-13316-1	5-3	170	28-13606-1	12-3	40
28-13316-913	5-3	180	28-13607-1	12-2	40
28-13318-1	5-3	340	28-13611-1	12-3	10
28-13318-7	5-3	340	28-13613-1	12-2	20
28-13319-1	5-4	60	28-13613-901	12-2	-20A
28-13321-11	5-4	430	28-13614-1	12-2	30
28-13321-13	5-4	430	28-13614-1	5-6	248
28-13321-15	5-4	430	28-13614-1DR	12-2	-30A
28-13321-17	5-4	430	28-13617-902	12-3	-5
28-13322-11	5-4	300	28-13617-903	12-2	-5
28-13323-11	5-4	280	28-13617-905	12-2	-5A
28-13401-4	5-4	200	28-13618-1	12-2	10
28-135003-1	12-1	30	28-13619-1	12-2	140
28-135003-11	12-1	30	28-13621-11	12-2	150
28-13511-11	12-1	180	28-13621-13	12-2	150
28-13515-3	12-1	50	28-13623-11	12-2	50A
28-13525-5	12-1	-10	28-13623-13	12-2	50B
28-13525-7	12-1	10A	28-13623-17	12-2	50C
28-13525-7	12-5	510	28-13623-25	12-2	60A
28-13531-11	12-1	140	28-13623-27	12-2	60B
28-13532-11	12-1	160	28-13623-29	12-2	60C
28-13600-3	12-2	60A	28-13623-31	12-2	60D
28-13600-4	12-2	60B	28-14004-1	4-1	380
28-13600-5	12-2	60C	28-14006-11	4-1	280
28-13600-6	12-2	50A	28-14006-13	4-1	280
28-13600-7	12-2	50B	28-14006-15	4-1	280
28-13600-8	12-2	50C	28-14006-17	4-1	280
28-13605-3	12-3	60	28-14006-19	4-1	280
28-13605-4	12-3	60	28-14006-3	4-1	280
28-13605-4	7-5	440	28-14006-5	4-1	280
28-13605-5	12-3	60	28-14006-7	4-1	280

ENSTROM F-28/280 SERIES ILLUSTRATED PARTS CATALOG

PART NUMBER INDEX SECTIONS 3 THROUGH 7 AND 9 THROUGH 12 FIGURES 8-1 THROUGH 8-11

Part Number	Figure	Item	Part Number	Figure	Item
28-14006-9	4-1	280	28-14228-15	4-1	170
28-14007-1	4-2	250	28-14231-1	4-2	50
28-14007-3	4-2	250	28-14233-2	4-3	60
28-14008-1	4-1	370	28-14233-3	4-3	60
28-14009-1	4-1	350	28-14234-9	4-2	–
28-14009-2	4-1	350	28-14234-901	4-2	–
28-14009-3	4-1	350	28-14234-909	4-2	–
28-14009-5	4-1	350	28-14235-1	4-1	360
28-14019-10	4-3	40	28-14236-1	4-1	220
28-14019-2	4-3	40	28-14236-1	4-1	270
28-14019-3	4-3	40	28-14236-1	4-3	30
28-14019-5	4-3	40	28-14239-1	4-2	210
28-14019-6	4-3	40	28-14239-11	4-2	–
28-14100-9	4-2	240	28-14239-3	4-2	–
28-14109-1	4-2	380	28-14239-5	4-2	210
28-14110-1	4-2	–	28-14240-1	4-2	20
28-14110-2	4-2	–	28-14244-1	4-1	80
28-14110-3	4-2	–	28-14248-1	5-3	510
28-14117-1	4-1	200	28-14250-1	4-1	–
28-14117-11	4-1	200	28-14250-1	8-4	40
28-14119-11	4-2	242	28-14250-3	8-4	50
28-14120-11	12-9	90	28-14251-1	4-1	230
28-14120-11	12-10	110	28-14251-2	4-1	240
28-14121-11	12-10	120	28-14256-1	4-1	290
28-14141-913	4-2	370	28-14257-1	4-1	300
28-14202-1	4-1	40	28-14259-1	4-3	150
28-14207-1	8-4	30	28-14259-3	8-4	160
28-14207-101	8-4	30	28-14259-3	8-5	480
28-14207-7	8-4	30	28-14261-1	4-2	100
28-14219-3	4-1	–	28-14262-1	8-4	80
28-14219-7	4-1	–	28-14265-3	4-4	100
28-14219-901	4-1	–	28-14268-1	4-4	–
28-14223-1	4-1	100	28-14270-1	4-2	–
28-14224-1	4-1	70	28-14270-1	11-21	360
28-14224-3	4-1	130	28-14276-1	4-4	20
28-14227-1	4-1	180	28-14277-1	4-4	30
28-14227-11	4-3	10	28-14278-1	4-2	330
28-14228-1	4-1	170	28-14278-1	8-4	10

ENSTROM F-28/280 SERIES ILLUSTRATED PARTS CATALOG

PART NUMBER INDEX SECTIONS 3 THROUGH 7 AND 9 THROUGH 12 FIGURES 8-1 THROUGH 8-11

Part Number	Figure	Item	Part Number	Figure	Item
28-14279-1	4-2	150	28-14372-1	4-4	70
28-14279-3	4-2	150	28-14372-3	4-4	70
28-14280-1	4-1	90	28-14374-13	11-21	370
28-14280-3	4-1	90	28-14374-15	4-4	290
28-14280-5	4-1	90	28-14374-15	11-21	370
28-14281-1R	4-1	120	28-14375-101	4-4	-
28-14281-3	4-1	120	28-14375-105	4-4	-
28-14281-5	4-1	120	28-14375-7	4-4	-
28-14282-11	4-2	10	28-14375-905	4-4	-
28-14282-13	4-2	10	28-14375-906	4-4	-
28-14283-1	4-2	280	28-14381-901	4-2.1	100
28-14290-3	4-1	110	28-14381-902	4-2.1	60
28-14290-5	4-1	110	28-14381-903	4-2	-
28-14290-7	4-1	110	28-14382-19	4-2.1	160
28-14290-9	4-1	110	28-14382-21	4-2.1	90
28-14293-11	4-2	180	28-14383-13	4-2.1	-70
28-14293-13	4-2	180	28-14384-13	4-2.1	-120
28-14293-7	4-2	180	28-14385-15	4-2.1	10
28-14293-9	4-2	180	28-14386-5	4-2.1	40
28-14311-1	4-2	70	28-14389-11	4-2.1	-110
28-14313-1	4-2	130	28-14389-13	4-2.1	-80
28-14320-15	4-2	170	28-150000-10	12-10	-
28-14335-1	4-2	190	28-150000-7	12-10	-
28-14356-5	4-4	121	28-150001-5	12-13	200
28-14357-3	4-4	10	28-150001-5	12-10	10
28-14357-5	4-4	10	28-150001-5	12-11	180
28-14358-3	4-4	50	28-150001-5	12-12	190
28-14358-4	4-4	120	28-150014-14	12-10	90
28-14359-15	4-4	20	28-150015-11	12-10	60
28-14359-17	4-4	30	28-150016-11	12-10	50
28-14366-1	4-4	210	28-15002-1	12-9	30
28-14367-7	4-4	220	28-150026-11	12-10	80
28-14368-1	6-11	280	28-150033-1	12-10	-
28-14368-2	4-4	230	28-150044-5	12-13	210
28-14369-1	4-4	270	28-150044-5	12-11	190
28-14370-15	4-4	60	28-150046-1	12-10	70
28-14370-17	4-4	60	28-150048-1	12-10	260
28-14371-1	4-4	80	28-150050-2	12-11	-

ENSTROM F-28/280 SERIES ILLUSTRATED PARTS CATALOG

PART NUMBER INDEX SECTIONS 3 THROUGH 7 AND 9 THROUGH 12 FIGURES 8-1 THROUGH 8-11

Part Number	Figure	Item	Part Number	Figure	Item
28-15005-1	12-9	170	28-150074-11	12-12	10
28-150051-1	12-11	70	28-150074-13	12-13	10
28-150053-1	12-11	120	28-150074-13	12-12	10
28-150055	12-10	–	28-150075-11	12-12	–30A
28-150055-1	12-13	150	28-150076-1	12-13	90
28-150055-1	12-11	290	28-150076-13	12-13	70
28-150055-1	12-12	140	28-150076-15	12-13	40
28-150055-13	12-13	150	28-150076-17	12-13	30
28-150055-15	12-13	–150A	28-150076-19	12-13	60
28-150060-11	12-13	120	28-150076-21	12-13	90
28-150060-11	12-10	–70A	28-150077-1	12-13	–
28-150060-11	12-11	160	28-150077-11	12-13	–
28-150060-11	12-12	110	28-150078-10	12-13	80
28-150062-11	12-11	90	28-150078-12	12-13	80
28-150062-13	12-11	90	28-150078-13	12-13	80
28-150063-11	12-13	130	28-150078-15	12-13	80
28-150063-11	12-10	–	28-150079-1	12-13	–
28-150063-11	12-11	280	28-150079-5	12-13	–
28-150063-11	12-12	120	28-150079-5	12-5	460
28-150063-13	12-13	–130A	28-150079-901	12-13	–
28-150064-11	12-11	60	28-15013-1	12-9	240
28-150066-11	12-11	140	28-15017-1	12-9	110
28-150067-11	12-12	20	28-15018-3	12-9	–
28-150067-13	12-12	–20A	28-15027-10	12-9	180
28-150067-15	12-13	20	28-15028-1	12-5	–
28-150070-11	12-12	40	28-15028-1	12-11	30
28-150070-13	12-12	–40A	28-15028-1	12-12	280
28-150072-1	12-12	60	28-15028-1	12-13	310
28-150072-10	12-12	60	28-15030-1	12-13	310
28-150072-11	12-12	90	28-15030-1	12-5	470
28-150072-2	12-12	60	28-15030-1	12-11	–
28-150072-20	12-12	60	28-15030-1	12-12	–
28-150072-21	12-12	70	28-15033-1	12-11	240
28-150072-3	12-12	60	28-15033-11	12-11	240
28-150072-5	12-12	60	28-15033-13	12-12	180
28-150072-7	12-12	60	28-15033-5	12-13	190
28-150073-1	12-12	–	28-15202-13	12-9	40
28-150073-5	12-12	–	28-15203-1	12-10	140

ENSTROM F-28/280 SERIES ILLUSTRATED PARTS CATALOG

PART NUMBER INDEX SECTIONS 3 THROUGH 7 AND 9 THROUGH 12 FIGURES 8-1 THROUGH 8-11

Part Number	Figure	Item	Part Number	Figure	Item
28-15203-3	12-9	60	28-16070-5	9-3	520
28-15203-4	12-9	60	28-16070-7	9-1	2B
28-15203-5	12-9	60	28-16070-7	9-4	120
28-15203-6	12-9	60	28-16070-9	9-1	2C
28-15206-1	12-9	50	28-16070-9	9-3	520
28-15206-1	12-10	150	28-16074-11	3-11	280
28-16006-1	3-10	320	28-16080-901	3-11	–
28-16011-1	3-11	500	28-16087-11	3-11	290
28-16021-11	3-11	370	28-16087-13	3-11	390
28-16021-11	3-11	370	28-16088-13	3-11	50
28-16022-11	3-11	490	28-16096-1	3-11	10
28-16022-11	3-13	10	28-16096-3	3-11	10
28-16024	8-3	–	28-16098-11	3-11	170
28-16024	8-5	–	28-16099-1	9-1	2D
28-16024	8-6	–	28-16101-101	8-1	–
28-16024	8-6A	–	28-16101-105	8-4	–
28-16024	8-8	–	28-16101-107	8-3A	–
28-16024-911	8-5A	–	28-16103-1	8-3A	50
28-16024-912	8-5A	–	28-16105-1	8-3A	30
28-16026-1	8-5	–180A	28-16106-2	8-3A	70
28-16026-3	8-5	–180B	28-16108-11	8-3A	90
28-16026-5	8-5	–180C	28-16108-2	8-3A	90
28-16026-7	8-5	–180D	28-16109-1	8-3A	230
28-16026-9	8-5	–180E	28-16109-11	8-3A	230
28-16030-1	6-14	–	28-16109-13	8-3A	240
28-16030-3	6-14	–	28-16110-1	8-3A	160
28-16043-13	8-3A	280	28-16112-15	8-3A	190
28-16043-15	8-3A	300	28-16112-17	8-3A	190
28-16043-19	8-3A	140	28-16113-1	8-3A	210
28-16056-1	8-5A	50	28-16116-1	8-1	220
28-16057-1	8-5A	110	28-16116-11	8-1	220
28-16069-3	9-4	–	28-16119-3	8-1	80
28-16069-5	9-3	–	28-16119-5	8-1	80
28-16070-101	9-1	2B	28-16123-1	8-1	10
28-16070-101	9-4	120	28-16123-11	8-1	10
28-16070-103	9-4	120	28-16124-1	8-2	40
28-16070-105	9-4	125	28-16125-3	8-3A	110
28-16070-5	9-1	2C	28-16125-4	8-3A	120

ENSTROM F-28/280 SERIES ILLUSTRATED PARTS CATALOG

PART NUMBER INDEX SECTIONS 3 THROUGH 7 AND 9 THROUGH 12 FIGURES 8-1 THROUGH 8-11

Part Number	Figure	Item	Part Number	Figure	Item
28-16125-5	8-3A	130	28-16183-1	8-5A	10
28-16126-1	8-3A	200	28-16183-901	8-5A	10
28-16129-2	8-2	30	28-16190-1	8-5	50
28-16131-1	8-3A	220	28-16191-1	8-5	60
28-16131-11	8-3A	220	28-16192-1	8-5	100
28-16132-1	8-3A	-	28-16197-1	8-3	160
28-16132-3	8-3A	340	28-16197-1	8-5	10
28-16132-4	8-3A	330	28-16198-1	8-3	130
28-16133-1	8-3A	350	28-16198-1	8-5	40
28-16136-1	8-5	-	28-162004-11	8-11	260A
28-16136-101	8-5	-	28-16201-1	8-3A	470
28-16136-103	8-5	-	28-16201-1	8-9	330
28-16136-5	8-5	-	28-16201-1	8-10	330
28-16143-1	8-3A	380	28-16202-1	8-5	540
28-16143-3	8-3A	380	28-16203-1	8-11	170
28-16145-1	8-5	220	28-16203-1	8-3A	480
28-16148-1	8-5A	40	28-16203-1	8-4	60
28-16148-3	8-5A	40	28-16203-1	8-8	80
28-16150-1	8-5A	30	28-162040-11	8-7	40
28-16153-1	12-5	-	28-162041-1	8-7	-10
28-16153-1	12-5	-	28-162041-2	8-7	-10
28-16154-1	12-5	200	28-162042-11	8-7	30
28-16155-4	8-5	120	28-162043-1	8-7	10
28-16155-4	8-6A	100	28-162043-1	8-9	-
28-16155-5	8-5	90	28-162043-3	8-9	-
28-16156-1	8-3	120	28-16205-1	8-5	290
28-16156-1	8-5	30	28-16205-5	8-5	290
28-16156-1	12-5	-	28-16206-11	8-4	20
28-16156-1	12-5	-	28-16209-1	8-5	490
28-16157-3	8-5	400	28-16209-11	8-5	-490A
28-16157-3	12-5	330	28-16210-3	8-5	530
28-16157-4	8-5	500	28-16210-3	7-5	930
28-16158-1	8-5	70	28-16211-1	8-5	390
28-16159-1	8-5	80	28-16211-1	8-8	130
28-16160-1	8-5	110	28-16211-1	7-5	-940
28-16160-7	8-5	110	28-16215-1	3-10	360
28-16160-7	8-6A	70	28-16215-1	11-21	380
28-16168-1	3-10	160	28-16217-11	8-5	360

ENSTROM F-28/280 SERIES ILLUSTRATED PARTS CATALOG

PART NUMBER INDEX SECTIONS 3 THROUGH 7 AND 9 THROUGH 12 FIGURES 8-1 THROUGH 8-11

Part Number	Figure	Item	Part Number	Figure	Item
28-16217-13	8-5	-360A	28-16239-9	8-11	40
28-16217-15	8-5	-360B	28-16242-1	8-11	-320
28-16217-17	8-5	-360C	28-16242-5	8-11	-350
28-16217-19	8-5	-360D	28-16242-7	8-11	-340
28-16217-21	8-5	-360E	28-16242-901	8-11	-310
28-16217-23	8-5	-360F	28-16242-907	8-11	-330
28-16218-1	8-5	20	28-16253-1	8-3A	460
28-16219-1	8-3	140	28-16253-101	8-3A	420
28-16220-1	8-5	300	28-16253-103	8-3A	420
28-16220-5	8-5	300	28-16253-105	8-3A	460
28-16222-1	8-11	260	28-16253-6	8-3A	450
28-16223-19	8-1	210	28-16253-8	8-3A	450
28-16224-5	8-1	230	28-16258-1	8-11	200
28-16225-19	8-1	240	28-16259-1	8-3A	20
28-16226-5	8-1	200	28-16260-1	8-3A	10
28-16227-3	8-1	160	28-16263-5	8-1	170
28-16228-1	8-1	50	28-16264-1	8-3A	40
28-16229-13	8-11	250	28-16283-2	8-6	80
28-16229-15	8-11	250	28-16283-2	8-6A	20
28-16230-1	8-11	240	28-16283-4	8-5	340
28-16231-1	8-11	280	28-16283-4	8-6	20
28-16232-1	8-11	30	28-16283-4	8-7	20
28-16233-1	8-11	180	28-16284-1	8-5	330
28-16234-1	8-11	80	28-16284-1	8-6	30
28-16235-1	8-11	120	28-16284-1	8-6A	90
28-16235-11	8-11	120	28-16290-2	8-5	320
28-16236-1	8-11	220	28-16290-2	8-6	70
28-16236-15	8-11	220	28-16290-2	8-6A	10
28-16236-17	8-11	220	28-16291-1	8-6	90
28-16237-1	8-11	230	28-16291-1	8-6A	30
28-16237-11	8-11	230	28-16292-11	8-6A	-
28-16237-13	8-11	230	28-16293-2	8-6	-
28-16238-3	8-11	290	28-16293-2	8-6A	-
28-16238-5	8-11	290	28-16294-1	8-6	10
28-16238-7	8-11	290	28-16294-1	8-6A	80
28-16239-1	8-11	40	28-16294-13	8-6A	80
28-16239-101	8-11	40	28-16295-1	8-6	-
28-16239-5	8-11	40	28-16296-11	11-21	390

ENSTROM F-28/280 SERIES ILLUSTRATED PARTS CATALOG

PART NUMBER INDEX SECTIONS 3 THROUGH 7 AND 9 THROUGH 12 FIGURES 8-1 THROUGH 8-11

Part Number	Figure	Item	Part Number	Figure	Item
28-16300	12-7	-5	28-16322-1	12-5	50
28-16300	12-9	-	28-16322-7	12-5	50
28-16301-3	12-8	10A	28-16322-9	12-5	-50A
28-16301-4	12-7	10	28-16324	12-7	110A
28-16301-4	12-8	10B	28-16325-2	12-7	120A
28-16301-7	12-7	10A	28-16331-1	12-7	10B
28-16301-7	12-8	10C	28-16331-1	12-8	20
28-16302-1	12-7	80	28-16331-1	12-5	-
28-16307-1	12-7	110	28-16334-1	12-5	40
28-16308-1	12-7	40	28-16334-3	12-5	70
28-16308-1	12-7	180	28-16334-5	12-5	-40A
28-16308-1	12-8	210	28-16334-7	12-5	-40B
28-16308-1	12-5	520	28-16334-9	12-5	-40C
28-16309-1	12-7	170	28-16336-11	8-3A	440
28-16310-2	12-7	30	28-16336-11	8-4	60
28-16310-2	12-8	200	28-16338-1	12-5	10
28-16310-2	12-5	530	28-16338-2	12-5	20
28-16311-1	12-7	20	28-16338-3	12-5	-
28-16311-1	12-7	165	28-16338-5	12-5	-
28-16311-1	12-8	-30	28-16338-5	12-5	-
28-16311-1	12-8	-170	28-16338-7	12-5	-
28-16311-1	12-8	-190	28-16339-1	12-5	30
28-16311-1	5-3	350	28-16339-3	12-5	-
28-16313-1	12-7	160	28-16339-4	12-5	-
28-16313-1	12-8	150	28-16339-5	12-5	-
28-16313-1	12-5	620	28-16339-6	12-5	-
28-16314-1	12-7	230	28-16339-7	12-5	-
28-16314-1	12-8	180	28-16340-1	12-5	430
28-16314-1	12-5	610	28-16341-1	12-5	100
28-16315-1R	12-7	230A	28-16342-1	12-5	370
28-16317-1R	12-7	160A	28-16345-1	12-6	130
28-16319-1	12-7	210	28-16345-1	12-5	650
28-16319-1	12-8	-160	28-16348-1	9-5	20
28-16320-1	12-7	120	28-16348-1	12-5	410
28-16321-1	12-5	60	28-16349-1	12-5	270
28-16321-101	12-5	-60A	28-16351-1	12-5	450
28-16321-103	12-5	-60B	28-16352-1	12-5	660
28-16321-105	12-5	-60C	28-16353-3	12-6	50

ENSTROM F-28/280 SERIES ILLUSTRATED PARTS CATALOG

PART NUMBER INDEX SECTIONS 3 THROUGH 7 AND 9 THROUGH 12 FIGURES 8-1 THROUGH 8-11

Part Number	Figure	Item	Part Number	Figure	Item
28-16353-3	12-10	240	28-16401-5	3-10	220
28-16353-4	12-10	230	28-16403-1	3-10	290
28-16353-5	12-6	30	28-16404-1	3-10	300
28-16353-5	12-5	720	28-164043-11	3-10	340
28-16355-1	12-5	90	28-164043-11	3-14	–
28-16361-1	8-1	20	28-164043-11	3-15	–
28-16361-1	8-3	10	28-16405-1	3-10	70
28-16374-1	12-8	140	28-16407-1	3-10	200
28-16374-1	12-5	590	28-16409-13	3-11	60
28-16380	12-8	–5A	28-16409-15	3-11	60
28-16380	12-10	–	28-16421-1	3-11	40
28-16386-1	8-3A	80	28-16447-1	3-10	20
28-16387-1	8-1	60	28-16449-1	3-10	350
28-16389-2	8-3A	150	28-16449-1	11-21	400
28-16390-11	8-5A	–20	28-16473-1	3-11	220
28-16391-1	12-6	120B	28-16473-1	3-11	440
28-16391-13	12-5	–	28-16476-2	3-11	150
28-16391-3	12-6	120A	28-16476-3	3-11	250
28-16391-5	12-6	120	28-16477-1	3-11	240
28-16391-5	12-5	500	28-16477-2	3-11	300
28-16392-13	12-6	180	28-16478-3	3-11	–
28-16392-13	12-8	60	28-16478-5	3-11	–
28-16392-13	12-5	–	28-16479-13	3-11	110
28-16394-11	12-5	–	28-16481-5	3-11	–
28-16394-2	12-8	40	28-16482-13	3-11	210
28-16395-1	12-8	120	28-16484-11	3-11	120
28-16395-1	12-5	550	28-16490-101	3-15	70
28-16396-2	12-8	10	28-16493-11	3-13	10
28-16396-2	12-5	540	28-16493-13	3-13	10
28-16397-11	12-8	50	28-16497-1	3-13	20
28-16397-11	12-5	–	28-16498-101	3-11	450
28-16398	12-6	–5	28-16498-101	3-13	80
28-16398	12-8	–5	28-16498-7	3-13	80
28-16398-103	12-5	–	28-16498-9	3-11	430
28-16398-901	12-6	120C	28-16498-9	3-11	450
28-16399-13	12-1	220	28-16499-9	3-12	100
28-164001-1	3-10	70	28-16499-9	3-12	100
28-16401-1	3-10	220	28-16504-1	5-5	130

ENSTROM F-28/280 SERIES ILLUSTRATED PARTS CATALOG

PART NUMBER INDEX SECTIONS 3 THROUGH 7 AND 9 THROUGH 12 FIGURES 8-1 THROUGH 8-11

Part Number	Figure	Item	Part Number	Figure	Item
28-16505-1	5-5	200	28-16600-111	8-8	20
28-16506-1	5-5	220	28-16600-113	8-8	90
28-16515-1	5-5	20	28-16600-113	8-10	–
28-16515-3	5-5	30	28-16600-115	8-8	10
28-16516-1	5-5	10	28-16600-115	8-9	–
28-16516-13	5-5	10	28-16600-117	8-8	100
28-16518-1	5-5	160	28-16600-117	8-10	–
28-16519-1	5-5	40	28-16600-119	8-8	20
28-16520-1	5-1	270	28-16600-119	8-9	–
28-16520-1	5-5	50	28-16600-7	8-8	100
28-16521-11	5-5	80	28-16600-8	8-8	20
28-16522-1	5-5	90	28-16600-9	8-8	100
28-16523-1	5-5	–	28-16601-1	8-9	420
28-16524-3	5-6	–	28-16601-1	8-10	420
28-16524-3	8-1	180	28-16603-1	8-10	440
28-16524-4	5-6	–	28-16603-15	8-10	430
28-16524-4	8-1	180	28-16604-1	8-9	410
28-16524-5	5-6	–	28-16604-1	8-10	410
28-16524-5	8-1	180	28-16607-1	8-9	270
28-16524-6	5-6	–	28-16607-1	8-10	270
28-16524-6	8-1	180	28-16608-1	8-9	300
28-16524-7	5-6	–	28-16608-1	8-10	300
28-16524-7	8-1	180	28-16609-1	8-9	200
28-16524-8	5-6	–	28-16609-1	8-10	200
28-16524-8	8-1	180	28-16610-1	8-9	180
28-16525-1	5-5	360	28-16610-1	8-10	180
28-16525-1	11-21	410	28-16611-1	8-9	360
28-16526-1	5-5	370	28-16611-1	8-10	360
28-16526-1	11-21	420	28-16611-13	8-9	360
28-16537-11	5-5	380	28-16611-13	8-10	360
28-16537-13	5-5	390	28-16611-15	8-9	360
28-16542-11	5-5	240	28-16611-15	8-10	360
28-16600-10	8-8	20	28-16612-5	8-9	–
28-16600-101	8-8	90	28-16612-5	8-10	–
28-16600-103	8-8	10	28-16613-1	8-9	350
28-16600-105	8-8	90	28-16613-1	8-10	350
28-16600-107	8-8	10	28-16613-3	8-9	350
28-16600-109	8-8	100	28-16613-3	8-10	350

ENSTROM F-28/280 SERIES ILLUSTRATED PARTS CATALOG

PART NUMBER INDEX SECTIONS 3 THROUGH 7 AND 9 THROUGH 12 FIGURES 8-1 THROUGH 8-11

Part Number	Figure	Item	Part Number	Figure	Item
28-16614-1	8-9	-10	28-16630-3	8-10	220
28-16614-1	8-10	-10	28-16630-4	8-9	220
28-16614-3	8-9	10	28-16632-1	8-9	260
28-16614-3	8-10	10	28-16632-1	8-10	260
28-16614-5	8-9	10	28-16633-1	8-9	140
28-16614-5	8-10	10	28-16633-1	8-10	140
28-16616-1	8-10	320	28-16635-1	8-9	250
28-16616-5	8-9	320	28-16636-3	8-9	-
28-16616-7	8-9	320	28-16636-3	8-10	-
28-16616-9	8-10	320	28-16636-5	8-9	-
28-16617-1	8-10	-	28-16636-5	8-10	-
28-16617-2	8-9	-	28-16637-11	8-6A	-
28-16618-101	8-10	310	28-16650-11	6-11	230
28-16618-103	8-7	-	28-17000-1	7-20	-
28-16618-103	8-9	310	28-17000-11	7-20	510
28-16618-105	8-10	310	28-17000-13	7-20	520
28-16618-6	8-9	310	28-17000-15	7-20	530
28-16618-7	8-10	310	28-17001-101	7-20	480
28-16618-9	8-9	310	28-17002-11	7-20	470
28-16619-1	8-9	160	28-17004-1	7-20	490
28-16619-1	8-10	160	28-17005-1	11-21	430
28-16620-1	8-10	-	28-17006-13	7-9	440
28-16620-2	8-9	-	28-17100-903	7-19	-
28-16621-1	8-9	-110A	28-17100-903	7-20	-
28-16621-1	8-10	-110A	28-17100-907	7-19	-
28-16623-1	8-10	250	28-17100-907	7-20	-
28-16624-1	8-9	-40	28-17100-923	7-19	-
28-16624-1	8-10	-40	28-17100-923	7-20	-
28-16624-11	8-9	40	28-17100-927	7-19	-
28-16624-11	8-10	40	28-17100-927	7-20	-
28-16624-3	8-9	40	28-17101-1	7-20	280
28-16624-3	8-10	40	28-17101-7	7-20	280
28-16625-1	8-8	50	28-17102-3	7-20	170
28-16626-1	8-9	390	28-17104-1	7-20	130
28-16628-1	8-9	340	28-17106-1	7-20	-
28-16628-1	8-10	340	28-17106-2	7-20	-
28-16630-1	8-10	220	28-17108-1	7-22	110
28-16630-2	8-9	220	28-17108-2	7-22	-120

ENSTROM F-28/280 SERIES ILLUSTRATED PARTS CATALOG

PART NUMBER INDEX SECTIONS 3 THROUGH 7 AND 9 THROUGH 12 FIGURES 8-1 THROUGH 8-11

Part Number	Figure	Item	Part Number	Figure	Item
28-17111-1	7-20	90	28-17142-5	7-22	-
28-17113-13	7-22	240	28-17142-7	7-22	-
28-17119-11	7-22	170	28-17143-11	7-22	260
28-17119-12	7-22	-180	28-17144-1	7-21	180
28-17119-13	7-22	-190	28-17144-5	7-21	180
28-17119-14	7-22	-200	28-17145-1	7-21	130
28-17119-15	7-22	170	28-17146-1	7-21	230
28-17120-11	7-22	100	28-17146-7	7-21	230
28-17121-1	7-20	320	28-17147-3	7-21	120
28-17122-1	7-19	-	28-17147-7	7-21	110
28-17122-1	7-20	200	28-17148-1	7-21	-
28-17122-3	7-20	220	28-17148-2	7-21	-
28-17122-5	7-20	210	28-17148-3	7-20	350
28-17123-1	7-20	-	28-17148-3	7-21	-
28-17123-1	7-21	50	28-17148-5	7-20	360
28-17124-1	7-20	50	28-17148-5	7-21	-
28-17129-1	7-20	230	28-17148-7	7-20	-370
28-17132-1	7-19	10	28-17148-7	7-21	-
28-17132-1	7-20	10	28-17149-1	7-21	150
28-17132-2	7-20	20	28-17150-1	7-19	20
28-17132-3	7-20	30	28-17150-1	7-20	430
28-17132-4	7-20	40	28-17150-13	7-19	50
28-17135-11	7-20	-	28-17150-13	7-20	340
28-17135-11	7-21	10	28-17151-1	7-21	140
28-17138-1	7-22	230	28-17153-1	7-21	-220
28-17139-1	7-22	130	28-17153-13	7-21	210
28-17139-2	7-22	-140	28-17154-1	7-21	-200
28-17139-3	7-22	150	28-17155-1	7-21	240
28-17139-4	7-22	-160	28-17156-1	7-21	250
28-17140-1	7-21	70	28-17156-3	7-21	250
28-17141-1	7-22	10	28-17157-1	7-21	260
28-17141-2	7-22	-20	28-17158-1	7-21	40
28-17141-3	7-22	30	28-17159-11	7-20	-
28-17141-4	7-22	-40	28-17161-11	7-22	210
28-17141-5	7-22	-50	28-17162-11	7-22	220
28-17141-6	7-22	-60	28-17164-13	11-21	110
28-17142-1	7-22	-	28-17166-1	7-20	380
28-17142-3	7-22	-	28-17166-2	7-20	-390

ENSTROM F-28/280 SERIES ILLUSTRATED PARTS CATALOG

PART NUMBER INDEX SECTIONS 3 THROUGH 7 AND 9 THROUGH 12 FIGURES 8-1 THROUGH 8-11

Part Number	Figure	Item	Part Number	Figure	Item
28-17200-3	7-15	–	28-180023-1	11-21	1140
28-17200-3	7-17	–	28-180030-1	11-21	1150
28-17201-1	7-15	–	28-180045-11	11-21	1160
28-17201-3	7-17	290	28-180045-13	11-21	1160
28-17202-1	7-15	250	28-180046-11	11-21	1170
28-17205-1	7-15	290	28-180046-13	11-21	1170
28-17205-1	7-17	270	28-180047-11	11-21	1180
28-17206-11	7-17	330	28-180047-13	11-21	1180
28-17206-13	7-17	–	28-180048-11	11-21	1190
28-17206-17	7-17	350	28-180048-13	11-21	1190
28-17207-1	7-17	300	28-180049-11	11-20	10
28-17302-3	3-2	160	28-180050-1	11-20	100
28-17306-1	7-20	–	28-180050-101	11-20	–100E
28-17306-1	7-21	–60	28-180050-103	11-20	–100F
28-17308-1	12-10	270	28-180050-105	11-20	–100G
28-17308-1	12-13	230	28-180050-107	11-20	–100H
28-17308-1	12-9	230	28-180050-109	11-20	–100I
28-17308-1	12-11	330	28-180050-11	11-20	–100E
28-17308-1	12-12	210	28-180050-111	11-20	–100J
28-17313-1	6-5	70	28-180050-13	11-20	–100F
28-17314-1	6-5	80	28-180050-15	11-20	–100G
28-17316-1	6-5	90	28-180050-17	11-20	–100H
28-17318-1	11-21	440	28-180050-3	11-20	–100A
28-17331-1	11-21	450	28-180050-5	11-20	–100B
28-17331-13	11-21	460	28-180050-7	11-20	–100C
28-17331-15	11-21	450	28-180050-9	11-20	–100D
28-180004-5	11-6	360	28-18005-1	11-21	470
28-180010-11	12-4	40A	28-180051-1	11-20	–
28-180012-1	11-21	1100	28-180051-101	11-20	–
28-180014-1	11-8	–	28-180051-103	11-20	–
28-180014-1	11-7	950	28-180051-105	11-20	–
28-180018-1	11-21	1110	28-180051-107	11-20	–
28-180020-11	11-8	175	28-180051-3	11-20	–
28-180020-11	11-9	55	28-180051-5	11-20	–
28-180020-11	11-6	110	28-180051-7	11-20	–
28-180020-11	11-7	50	28-180051-9	11-20	–
28-180021-1	11-21	1120	28-180052-11	11-21	1200
28-180022-1	11-21	1130	28-180052-13	11-21	1200

ENSTROM F-28/280 SERIES ILLUSTRATED PARTS CATALOG

PART NUMBER INDEX SECTIONS 3 THROUGH 7 AND 9 THROUGH 12 FIGURES 8-1 THROUGH 8-11

Part Number	Figure	Item	Part Number	Figure	Item
28-180053-11	11-21	1210	28-18015-1	11-21	540
28-180053-13	11-21	1210	28-18016-1	11-21	550
28-180054-11	11-21	1220	28-18020-1	11-18	–
28-180054-13	11-21	1220	28-18020-1	12-4	–10
28-180055-11	11-21	1230	28-18020-3	12-4	–10A
28-180055-13	11-21	1230	28-18020-5	11-18	–
28-180056-11	11-21	1240	28-18020-5	12-4	–130
28-180056-13	11-21	1240	28-18020-7	11-18	–
28-180057-11	11-21	1250	28-18020-7	12-4	–240
28-180057-13	11-21	1250	28-18024-1	12-4	170
28-18006-1	11-21	480	28-18024-5	11-18	100
28-180067-1	11-20	150	28-18024-5	12-4	170
28-180067-101	11-20	–150E	28-18026-1	12-4	230
28-180067-103	11-20	–150F	28-18026-3	11-18	120
28-180067-105	11-20	–150G	28-18026-3	12-4	230
28-180067-107	11-20	–150H	28-18027-1	11-18	85
28-180067-109	11-20	–150I	28-18027-1	12-4	40
28-180067-201	11-20	–150J	28-18028-1	11-18	20
28-180067-203	11-20	–150K	28-18028-1	12-4	250
28-180067-205	11-20	–150L	28-18030-1	11-18	90
28-180067-207	11-20	–150M	28-18030-1	12-4	210
28-180067-209	11-20	–150N	28-18031-1	12-4	30
28-180067-211	11-20	–150O	28-18031-3	11-15	75
28-180067-213	11-20	–150P	28-18031-3	12-4	30
28-180067-215	11-20	–150Q	28-18032-1	11-2	–
28-180067-217	11-20	–150R	28-18033-1	11-8	425
28-180067-219	11-20	–150S	28-18033-1	11-9	335
28-180067-3	11-20	–150A	28-18033-1	11-7	890
28-180067-5	11-20	–150B	28-18033-1	11-14	100
28-180067-7	11-20	–150C	28-18033-11	11-15	75
28-180067-9	11-20	–150D	28-18034-1	11-18	105
28-18007-1	11-21	490	28-18034-1	12-4	200
28-18009-11	11-21	210	28-18035	11-1	–
28-18009-15	11-21	120	28-18036	11-1	110
28-18011-1	11-21	500	28-18036-10	11-1	120
28-18012-1	11-21	510	28-18036-10	11-4	–
28-18013-1	11-21	520	28-18036-10	11-5	–
28-18014-1	11-21	530	28-18036-9	11-1	370

ENSTROM F-28/280 SERIES ILLUSTRATED PARTS CATALOG

PART NUMBER INDEX SECTIONS 3 THROUGH 7 AND 9 THROUGH 12 FIGURES 8-1 THROUGH 8-11

Part Number	Figure	Item	Part Number	Figure	Item
28-18036-9	11-3	270	28-18069-17	11-7	470C
28-18036-9	11-5	–	28-18069-17	11-7	490
28-18036--9	11-2	270	28-18069-19	11-5	–
28-18037-1	11-21	560	28-18069-21	11-5	–
28-18037-2	11-21	570	28-18069-31	11-8	220
28-18037-3	11-21	580	28-18069-31	11-7	–470
28-18043	11-2	240	28-18069-33	11-8	235
28-18043-1	11-21	590	28-18069-33	11-7	–470B
28-18048-1	11-21	600	28-18075-1	3-10	350
28-18049	11-1	360	28-18081-11	6-3	–
28-18049	11-2	260	28-18081-11	11-6	200
28-18050	11-1	–	28-18081-11	11-21	630
28-18050	11-2	–	28-18082-1	11-3	–
28-18051	11-1	350	28-18082-9	11-5	20
28-18051-3	11-2	250	28-18082-9	11-6	320
28-18052-1	11-6	450	28-18084-1	11-8	–
28-18052-1	11-21	610	28-18084-5	11-5	–
28-18053-1	11-6	520	28-18087-1	11-21	640
28-18053-1	11-21	620	28-18088-1	11-21	650
28-18060-11	11-8	25	28-18088-2	11-21	660
28-18060-11	11-9	30	28-18091-1	11-5	–
28-18060-11	11-7	130	28-18091-101	11-5	–
28-18060-13	11-8	105	28-18091-103	11-5	–
28-18060-13	11-9	35	28-18091-105	11-5	–
28-18060-13	11-7	130A	28-18091-107	11-5	–
28-18060-15	11-8	100	28-18091-109	11-5	–
28-18060-15	11-9	75	28-18091-111	11-5	–
28-18060-15	11-7	130B	28-18091-113	11-5	–
28-18061-1	11-8	330	28-18091-121	11-6	–490A
28-18061-1	11-9	260	28-18091-123	11-6	420
28-18061-1	11-7	720A	28-18091-131	11-5	–
28-18061-1	11-12	20	28-18091-133	11-5	–
28-18061-1	11-13	170	28-18091-3	11-5	–
28-18061-1	11-13	200	28-18091-5	11-5	–
28-18061-1	11-13	210	28-18091-5	11-6	490
28-18061-1	11-13	220	28-18092-11	11-21	670
28-18061-3	11-7	–720	28-18095-1	11-5	300
28-18069-15	11-7	470A	28-18095-3	11-5	300A

ENSTROM F-28/280 SERIES ILLUSTRATED PARTS CATALOG

PART NUMBER INDEX SECTIONS 3 THROUGH 7 AND 9 THROUGH 12 FIGURES 8-1 THROUGH 8-11

Part Number	Figure	Item	Part Number	Figure	Item
28-18095-6	11-5	300B	28-18103-5	3-22	510
28-18099-101	11-5	-	28-18103-5	11-10	140
28-18099-111	11-5	-	28-18103-6	11-10	150
28-18099-119	11-5	-	28-18103-7	11-10	160
28-18099-125	11-5	-	28-18103-7	11-11	-140A
28-18099-147	11-8	-	28-18104-3	11-14	30
28-18099-149	11-7	-	28-18104-4	11-14	40
28-18099-157	11-7	-	28-18104-5	11-14	50
28-18099-159	11-8	-	28-18104-6	11-14	60
28-18099-161	11-7	-	28-18104-7	11-14	70
28-18099-165	11-7	-	28-18104-903	11-12	110
28-18099-169	11-7	-	28-18104-903	11-13	10
28-18099-171	11-9	-	28-18104-904	11-12	90
28-18099-173	11-9	-	28-18104-904	11-13	20
28-18099-3	11-6	-	28-18104-905	11-12	100
28-18099-7	11-6	-	28-18104-905	11-13	30
28-18100-11	11-21	680	28-18104-906	11-12	80
28-181001-11	3-22	480	28-18104-906	11-13	40
28-181001-11	3-23	500	28-18104-907	11-12	60
28-181001-3	3-23	500	28-18104-907	11-13	50
28-181002-1	3-22	510	28-18105-11	11-21	130
28-181002-1	3-23	530	28-18105-13	11-21	690
28-181005-1	11-6	210	28-18107-1	11-21	700
28-181005-13	11-16	140	28-18108-1	11-21	710
28-181006-11	3-3	140	28-18112-1	11-11	50
28-181007-1	3-3	120	28-18113-1	11-11	30
28-181007-3	3-3	120	28-18143-11	6-11	260
28-181007-5	3-3	120	28-18153-105	11-7	310B
28-181008-1	3-20	-	28-18153-107	11-7	310
28-181008-1	3-20A	-	28-18153-109	11-8	85
28-181008-1	3-20B	-	28-18153-109	11-7	-310A
28-18101-11	11-8	145	28-18156-1	11-6	20
28-18101-11	11-7	370	28-18156-3	11-6	-20A
28-18103-3	3-22	480	28-18158-1	9-3	-
28-18103-3	11-10	130	28-18158-1	9-4	-
28-18103-4	3-22	480	28-18158-3	9-3	-
28-18103-4	11-11	10	28-18158-3	9-4	-
28-18103-4	11-11	140	28-18159-11	9-3	-

ENSTROM F-28/280 SERIES ILLUSTRATED PARTS CATALOG

PART NUMBER INDEX SECTIONS 3 THROUGH 7 AND 9 THROUGH 12 FIGURES 8-1 THROUGH 8-11

Part Number	Figure	Item	Part Number	Figure	Item
28-18159-11	9-4	–	28-18167-19	6-12	10
28-18159-13	9-3	–	28-18167-21	6-12	10
28-18159-13	9-4	–	28-18167-23	6-12	10
28-18161-11	9-3	–	28-18167-25	6-12	10
28-18161-11	9-4	–	28-18167-27	6-12	10
28-18161-15	9-3	–	28-18167-5	11-19	15
28-18161-15	9-4	–	28-18171-29	11-7	500B
28-18161-17	9-4	–	28-18171-31	11-7	500
28-18161-19	9-4	–	28-18171-33	11-8	230
28-18162-13	9-3	–	28-18171-33	11-7	–500A
28-18162-13	9-3	–	28-18200-1	11-8	365
28-18162-13	9-4	–	28-18200-1	11-7	–760
28-18162-13	9-4	–	28-18200-3	11-7	760A
28-18162-14	9-3	–	28-19001-943	6-4	70
28-18162-14	9-4	–	28-19001-948	6-4	60
28-18162-14	9-4	–	28-19003	6-1	80
28-18162-14	9-3	–	28-19004	6-1	10
28-18162-15	9-3	–	28-19006-24-1	7-13	80
28-18162-15	9-4	–	28-19016-11	6-2	70
28-18162-15	9-4	–	28-19021-10	11-8	280
28-18162-17	9-3	–	28-19021-10	11-9	200
28-18162-17	9-4	–	28-19021-10	11-7	590
28-18162-17	9-4	–	28-19021-10	11-7	800
28-18164-3	9-3	–	28-19021-13	8-5	–130B
28-18164-3	9-4	–	28-19021-15	8-5	–130A
28-18164-5	9-3	–	28-19021-17	8-5	–150A
28-18164-5	9-4	–	28-19021-19	8-5	–130C
28-18165-5	11-19	115	28-19021-2	8-5	130
28-18166-1	9-3	10	28-19021-21	8-5	–150B
28-18166-1	9-4	10	28-19021-23	8-5	–130D
28-18166-3	9-3	10A	28-19021-25	8-5	–130E
28-18166-3	9-4	10A	28-19021-27	8-5	–150C
28-18166-5	9-4	10A	28-19021-29	8-5	160
28-18166-7	9-4	10	28-19021-3	8-5	150
28-18167-11	6-12	10	28-19021-31	8-5	140
28-18167-13	6-12	10	28-19021-33	8-5	170
28-18167-15	6-12	10	28-19021-35	8-5	–130F
28-18167-17	6-12	10	28-19021-37	8-5	–130G

ENSTROM F-28/280 SERIES ILLUSTRATED PARTS CATALOG

PART NUMBER INDEX SECTIONS 3 THROUGH 7 AND 9 THROUGH 12 FIGURES 8-1 THROUGH 8-11

Part Number	Figure	Item	Part Number	Figure	Item
28-19021-39	8-5	-160A	28-19103-1	6-10	40
28-19021-41	8-5	-140A	28-19104-1	6-9	40
28-19021-43	8-5	-170A	28-19105-1	6-10	50
28-19023	11-8	380	28-19105-1	6-9	60
28-19023	11-9	290	28-19106-1	6-9	30
28-19023	11-7	830	28-19106-3	6-10	30
28-19025-1	6-14	70	28-19106-3	6-9	30
28-19027-13	11-8	10	28-19106-5	6-10	30
28-19027-13	11-7	10	28-19106-5	6-13	90
28-19031	11-5	-	28-19106-5	6-9	30
28-19032	11-5	-	28-19123-9	11-8	375
28-19037-11	11-21	720	28-19123-9	11-9	285
28-19040-5	6-14	-	28-19123-9	11-7	820
28-19041	11-6	10	28-19131-1	6-11	-
28-19041-111	6-11	-	28-19132-3	6-5	200
28-19045-1	11-5	280	28-20000	7-15	-
28-19045-3	11-5	280A	28-20100-1	7-15	-10
28-19045-5	11-5	280B	28-20100-2	7-15	-20
28-19045-7	11-5	280C	28-20100-6	7-15	30
28-19045-9	11-5	280D	28-20100-7	7-15	40
28-19046-11	11-8	15	28-20107-11	11-21	140
28-19046-11	11-9	15	28-20107-11	11-21	750
28-19046-11	11-7	40	28-20107-11	7-15	300
28-19046-11	11-21	730	28-20107-11	7-16	270
28-19047-1	6-11	250	28-20107-13	11-21	750
28-19047-11	6-11	250	28-20107-13	7-15	-310
28-19048-11	6-11	230	28-20107-13	7-16	-280
28-19048-13	6-11	230	28-20111-1	7-17	30
28-19055-11	6-13	140	28-20111-2	7-17	40
28-19064-1	11-9	45	28-20111-911	7-17	30
28-19064-1	11-7	20	28-20111-912	7-17	40
28-19073	6-12	-	28-20112-1	7-17	50
28-19073-1	11-7	740	28-20112-15	7-17	50
28-19073-101	11-8	360	28-20112-16	7-17	60
28-19073-3	11-7	740A	28-20112-2	7-17	60
28-19073-5	11-7	740B	28-20116-11	7-17	70
28-19073-7	11-7	740C	28-20119-1	7-17	10
28-19101-11	11-21	740	28-20119-2	7-17	20

ENSTROM F-28/280 SERIES ILLUSTRATED PARTS CATALOG

PART NUMBER INDEX SECTIONS 3 THROUGH 7 AND 9 THROUGH 12 FIGURES 8-1 THROUGH 8-11

Part Number	Figure	Item	Part Number	Figure	Item
28-20119-3	7-17	10	28-21048-5	6-5	–
28-20119-4	7-17	20	28-21048-5	6-6	110A
28-21000-1	6-4	–	28-21048-6	6-5	–
28-21002	6-4	340	28-21048-6	6-6	110B
28-21002-3	6-4	340	28-21048-7	6-5	–
28-21002-3	6-6	10	28-21048-7	6-6	110A
28-21002-4	6-4	340	28-21048-8	6-5	–
28-21002-4	6-6	10	28-21048-8	6-6	110B
28-21003-1	6-4	330	28-21048-9	6-5	–
28-21003-1	6-4	40	28-21048-9	6-6	110C
28-21004-1	6-6	40	28-21050-11	6-7	180
28-21006-1	6-4	250	28-21051-11	6-7	*50
28-21007-1	6-4	240	28-21052-1	6-7	–
28-21008-1	6-4	230	28-21053-3	6-7	–
28-21009-1	6-4	220	28-22013-1	11-21	780
28-21009-1	6-5	205	28-22016-1	11-21	790
28-21009-1	6-5	60	28-22016-5	11-21	790
28-21009-1	6-7	170	28-22018-1	11-21	800
28-21009-1	6-8	10	28-22018-2	11-21	810
28-21010-3	6-5	235	28-22019-1	11-21	820
28-21011-1	6-4	180	28-22031-1	3-5A	–
28-21011-1	6-6	80	28-22032-1	3-5A	160
28-21012-1	6-4	160	28-22034-11	3-5A	30
28-21012-1	6-6	240	28-22081-5	11-8	–
28-21014-1	6-4	270	28-22093-3	11-8	140
28-21017-1	3-21	70	28-22093-3	11-9	60
28-21021-1	11-21	760	28-22093-3	11-19	–
28-21024-1	6-7	20	28-22093-3	11-7	350
28-21034-1	6-7	40	28-22094-11	11-19	155
28-21035-5	6-7	10	28-22094-13	11-19	110
28-21035-5	11-21	770	28-22096-11	11-19	125
28-21043-1	6-7	130	28-22101	9-3	390
28-21048-1	6-5	–	28-22101-1	9-2	29
28-21048-1	6-6	110A	28-22102-1	9-2	38
28-21048-101	6-5	–	28-22117	9-3	320
28-21048-101	6-6	110D	28-22117-3	9-2	37
28-21048-3	6-5	–	28-22165-1	7-1	–
28-21048-3	6-6	110B	28-22165-1	7-3	80

ENSTROM F-28/280 SERIES ILLUSTRATED PARTS CATALOG

PART NUMBER INDEX SECTIONS 3 THROUGH 7 AND 9 THROUGH 12 FIGURES 8-1 THROUGH 8-11

Part Number	Figure	Item	Part Number	Figure	Item
28-22199-1	9-2	34	28-22606-1	11-21	1020
28-22208-11	9-5	105	28-22607-1	11-21	1030
28-22209-101	9-5	110	28-22608-1	11-21	1040
28-22209-103	9-5	110	28-22609-11	11-21	1050
28-22210-9	9-5	–	28-22613-1	11-21	1060
28-22216-13	11-21	830	28-22615-11	11-21	1070
28-22343-1	11-21	840	28-22615-13	11-21	1080
28-22344-5	11-5	–	28-22615-15	11-21	1070
28-22350-1	8-3A	–	2852	11-17	240
28-22421-1	7-20	90	2855	11-17	260
28-22501-1	11-21	850	286377	6-12	60
28-22501-10	11-21	940	2870	11-17	250
28-22501-11	11-6	330	2871	11-17	230
28-22501-2	11-21	860	28775-214	5-6	200
28-22501-3	11-21	870	28NBC2040YZP	4-1	210
28-22501-4	11-21	880	28NBC2040YZP	4-1	340
28-22501-5	11-21	890	2904-33	11-2	300
28-22501-6	11-21	900	2904-33	11-3	300
28-22501-7	11-21	910	2904-33	11-5	–
28-22501-8	11-21	920	2904-33F5	11-1	400
28-22501-9	11-21	930	2904-33F5	11-4	–
28-22504-1	11-21	950	2D8934	5-6	50
28-22505-1	11-21	960	3/8 Harper	5-3	320
28-22506-1	11-21	970	3/8-6NA	11-19	190
28-22507-1	11-21	980	30-0009-36	6-6	50
28-22508-1	11-21	990	300-037	6-10	20
28-22540-11	11-21	1000	300-071	7-4	70
28-22540-17	11-8	155	300-071-CS	7-1	90
28-22540-17	11-7	320	300-072	7-4	80
28-22540-19	11-19	10	30-1UL	11-8	20
28-22543-11	11-17	220	30-1UL	11-9	20
28-22543-11	11-21	1010	30-1UL	11-5	290
28-22543-13	11-8	135	30-1UL	11-7	30
28-22543-13	11-9	65	3028-3/32	11-8	505
28-22543-13	11-7	340	3028-3/32	11-8	520
28-22561-3	6-13	10	304R	12-10	40
28-22562-17	6-13	50	306590	5-4	140
28-22563-5	6-13	100	313	6-5	20

ENSTROM F-28/280 SERIES ILLUSTRATED PARTS CATALOG

PART NUMBER INDEX SECTIONS 3 THROUGH 7 AND 9 THROUGH 12 FIGURES 8-1 THROUGH 8-11

Part Number	Figure	Item	Part Number	Figure	Item
3-1AF	7-5	140	3498T613	7-4	70
31B22111	3-31	-	35-140-A	11-4	-
325E10-2	3-8	50	37A19773-376	3-21	-
32-5R	6-4	310	38-0230021-00	6-4	-
327	11-8	50	38-0230021-00	6-4	-
327	11-9	-	38-0230021-00	6-4	-
327	11-7	80	381N-500-S	11-8	-
32-7L	6-4	320	381N-500-S	11-9	-
32NBC2044YZP	4-2	110	3-904 V0894-90	3-8	66
330	6-4	-	3A1535-B96-A100	3-10	60
330	11-1	-	3A-3140	3-10	60
330	11-1	-	3A-3308	7-4	70
330	11-2	-	3A3408-2	10-4	220
330	11-2	-	3AG-1A	11-17	50
330	11-3	-	3BT5EE10J2	3-3	200
330	11-4	-	3BT5EE10J2	3-8	50
330	11-4	-	3MC1-3-2	6-3	-
330	11-5	-	3MC1-3-2	11-5	250
33-199-36	3-22	-	3MC1-3-2	11-6	190
33-199-36	3-23	-	400-003	3-5A	50
33-199-916	3-22	260	400-003	3-5A	80
33-199-916	3-23	270	400510	11-19	35
338382	5-4	140	4016	11-8	470
34-0070371-02	6-4	150	4016-1	7-5	40
34-0070373-01	6-4	-	4016-75	7-5	100
34-0070373-01	6-4	-	40NBC2052YZP	4-2	90
34-0070373-01	6-4	-	4115001-19	9-3	340
34-0070373-01	6-4	90	4118265-21	7-6	190
34-0070373-01	6-6	350	4118278-21	7-6	80
34-0070373-03	6-6	350	4118278-23	7-6	30
34-0412070-63	6-6	140	4118283-11	7-6	50
34-0412070-63	6-6	440	4118284-13	7-6	100
34-0414020-65	6-4	-	4118290-15	7-6	-630
34-0414020-65	6-4	-	4118290-16	7-6	620
34-0414020-65	6-4	-	4119780-23	9-5	20
34-0428020-65	6-6	390	4119835-33	11-8	355
34-0428070-64	6-6	140	4119835-33	11-8	5
340823	5-4	290	4119835-33	6-12	20

ENSTROM F-28/280 SERIES ILLUSTRATED PARTS CATALOG

PART NUMBER INDEX SECTIONS 3 THROUGH 7 AND 9 THROUGH 12 FIGURES 8-1 THROUGH 8-11

Part Number	Figure	Item	Part Number	Figure	Item
4119839-11	7-6	-290	4234	3-26	20
4119920-11	11-21	150	4235	3-26	50
4119920-13	11-21	160	4241	3-26	70
4119920-15	11-21	170	428-3-VG	12-5	780
4150008-5	12-5	25	43-13-1-24	3-20	-
4164	6-13	191	43-13-1-24	3-20	-
4166053-11	8-9	-	43-13-1-24	3-20A	-
4166053-11	8-10	-	43-13-1-24	3-20A	-
4166053-13	8-9	-	43-13-1-24	3-20B	-
4166053-13	8-10	-	43-13-1-24	3-20B	-
4166053-15	8-9	-	43-13-1-24	7-1	-
4166053-15	8-10	-	43-13-1-24	7-8	240
4192509-901	6-11	10	43-13-1-24	7-18	-
4196603-23	11-8	75	43-13-1-24	7-18	-
4196603-23	11-9	-	43-13-1-24	7-18	-
4196603-23	11-7	170	43-13-1-24	7-18	-
4196609-11	6-14	80	4316	7-5	220
4199059-1	6-14	70	439-4-8-2-6	11-15	95
4199059-3	6-14	70	439-4-8-2-6	11-13	80
4199072-11	6-11	-	439-4-8-2-6	11-14	-
41EN-G3-2311	11-1	-	4406	6-5	50
41EN-G3-2311	11-1	-	444-4-2-6	11-15	120
41EN-G3-2311	11-1	-	444-4-2-6	3-24	230
41EN-G3-2311	11-2	-	444-4-4-2-6	11-13	90
41EN-G3-2311	11-2	-	444-4-4-2-6	11-14	90
41EN-G3-2311	11-2	-	4503	3-26	90
41EN-G3-2311	11-3	-	4508-1	7-16	290
41EN-G3-2311	11-3	-	4508-2	3-20	630
41EN-G3-2311	11-5	-	4508-2	3-20A	630
41EN-G3-2313	11-1	-	4508-2	3-20B	630
41EN-G3-2313	11-2	-	4508-75	8-5	620
41EN-G3-2313	11-3	-	4509	6-4	210
41EN-G3-2313	11-5	-	4509	6-7	60
41EN-G5-2312	11-1	-	4509	6-8	20
41EN-G5-2312	11-2	-	4591	6-5	50
4208-00	3-26	100	4596	6-8	20A
4222	3-26	140	4600-00	3-26	-
4232	3-26	10	471-RED	7-21	-

ENSTROM F-28/280 SERIES ILLUSTRATED PARTS CATALOG

PART NUMBER INDEX SECTIONS 3 THROUGH 7 AND 9 THROUGH 12 FIGURES 8-1 THROUGH 8-11

Part Number	Figure	Item	Part Number	Figure	Item
488-4D28-20	3-8	20	550	9-4	70
48P6	3-23	171	551-5	11-11	220
4910-50	7-4	-	55-4527-1067	3-14	80
49726	11-13	-	57-3255-2121	3-10	60
4FBTX-D	3-24	80	57-3255-2121	3-15	70
4-FBTX-D	3-22	310	58390	6-11	50
4JBTX-D	3-24	100	588-6D1	3-4	140
4-LHBTX-S	3-22	440	59-022-094-0500	5-5	70
4SN-188-C-73	5-5	230	5934	11-1	160
4-VBTX-S	3-22	420	5934	11-3	50
4WBTX-S	3-24	180	5934	11-4	50
5/16 HARPER	8-4	150	5934-1	11-2	50
5/8-6B	11-20	20	5934M	11-2	-50A
5/8-6NA	6-6	290	5934PD-3-A.253	11-5	60
5002-268-PP	12-5	-	5934PD-3-A.253	11-7	120
5045	4-2	160	5934PD-3-A.253	11-8	60
507-507-101	11-1	80	5934PD-3-A.253	11-9	40
507-507-101	11-1	320	5-W-140	7-1	510
507-507-101	11-1	340	6 X 3/8	11-8	350
507-507-101	11-2	-	6 X 3/8	11-19	20
507-507-101	11-2	210	6 X 3/8	11-7	750
507-507-101	11-2	230	6 X 3/8	7-20	190
507-507-101	11-3	-	600700-0000	3-3	200
507-507-101 (7.5A)	11-5	220	600700-0000	3-8	50
5102-137-PP	12-7	130	601002-4-0120	11-10	50
5108-100	7-20	500	601002-6-0180	3-4	90
511T1-2	11-1	50	601002-6-0180	3-6	50
511TS1-2	11-1	60	6041-ED22	6-2	20
52305A15-6	7-1	190	6041H34	6-1	30
5-295	7-1	520	60617-1	11-7	-
5310-00-063-9015	6-6	300	60618-1	11-8	-
5451	7-18	-	60618-1	6-11	-
5451	7-18	-	60618-1	11-7	-
5451	7-18	-	60685K31	7-6	-455
550	9-3	70	60686K31	7-6	-525
550	9-3	90	608036-1	11-19	-
550	9-4	110	608036-1	11-19	-
550	9-4	220	608036-1	11-19	-

ENSTROM F-28/280 SERIES ILLUSTRATED PARTS CATALOG

PART NUMBER INDEX SECTIONS 3 THROUGH 7 AND 9 THROUGH 12 FIGURES 8-1 THROUGH 8-11

Part Number	Figure	Item	Part Number	Figure	Item
608036-1	11-19	–	68-4230020-40	6-6	120A
608036-1	11-19	–	68-4230020-40	6-6	30
608036-1	11-19	–	68-4230020-50	6-4	–
62	3-24	550	68-4230020-50	6-6	120
624100-4-0120	3-22	430	68-4230020-50	6-6	30
624100-6-0060	3-22	410	68-4250066-30	6-6	410
624100-6-0180	3-6	60	68-4270002-30	6-6	430
624117-6-0180	3-22	350	6-F5OX-S	3-22	210
624117-6-0180	3-6	50	6RX1/2	8-5	610
62447-6-180	3-4	90	6-S5OX-S	3-22	360
6312-H69	11-4	–40A	6-V5OX-S	3-22	140
6312-H69A	11-2	40	6x1/2	9-1	5
6312-H69A	11-3	40	6x1/2	9-2	4
6-4 C5OX-S	3-8	67	6X3/8	6-12	30
64021	6-9	20	700-001-10	11-6	440
64-632-74	3-24	430	700-001-15	11-1	90
6487923	3-1	30	700-001-20	11-1	100
6487923	3-2	30	700-001-20	11-5	240
65-29AP	11-1	180	700200	11-19	25
65-29AP	11-4	70	700702-16	11-19	175
65-29B	11-2	70	702-5123	8-5	–180G
65-29B	11-3	70	702-5130	8-5	–180H
65-29B	11-4	–70A	7079B-12	6-4	150
65-4527-2229	3-10	10	7101SYZQE	11-8	150
65-4527-2229	3-14	80	7101SYZQE	11-9	185
65614	3-20	420	7101SYZQE	11-19	30
65614	3-20A	420	7101SYZQE	11-7	680
65614	3-20B	420	7101SYZQE	11-17	30
65614	3-9	140	72-028-125-0500	7-1	330
66224	3-3	150	7203BTVPUO	12-9	160
6-6FBTX-D	3-24	270	7235-1-100	6-13	185
6-6FBTX-S	3-22	230	7235-1-100	6-3	10
67-02-E-18-64S	8-5	190	726607	6-11	40
67-06-C-18-64P	8-5	200	726621	5-6	130
6-8 F5OX-S	3-23	120	726621	6-11	–
68-2290005-30	6-6	400	7270-1-20	11-5	200
68-4230020-30	6-4	–	7270-1-3	11-8	255
68-4230020-40	6-4	–	7270-1-3	11-9	135

ENSTROM F-28/280 SERIES ILLUSTRATED PARTS CATALOG

PART NUMBER INDEX SECTIONS 3 THROUGH 7 AND 9 THROUGH 12 FIGURES 8-1 THROUGH 8-11

Part Number	Figure	Item	Part Number	Figure	Item
7270-1-3	11-5	190	755-2-2-6	10-3	–
7270-1-3	11-7	540	755-2-2-6	10-3	–
7270-1-35	11-8	240	755-2-2-6	10-4	140
7270-1-35	11-9	130	755-2-2-6	10-4	240
7270-1-35	11-7	510	770001-5	11-8	285
7270-1-5	11-8	250	770001-5	11-9	205
7270-1-5	11-9	140	770001-5	11-7	600
7270-1-5	11-5	180	773-4/50 VDC	11-1	30
7270-1-5	11-7	520	773-4/50 VDC	11-5	–
7270-1-7 1/2	11-7	550	773-8/50 VDC	11-5	–
7270-1-7 1/2	11-8	260	77611	3-27	80
7270-1-7 1/2	11-9	145	77611	3-28	140
7270-1-7 1/2	11-5	170	786-4	3-24	120
7270-1-7 1/2	11-1	–	786-4-CU	3-24	120
7274-2-10	11-8	205	79012-062-0500	12-4	220
7274-2-10	11-7	440	79-012-062-0500	11-18	95
7274-2-2 1/2	11-7	420	79-028-125-0687	7-1	240
7274-2-2 1/2	11-8	195	79-048-250-0625	5-5	60
7274-2-3	11-8	215	8 X 1/2	7-10	260
7274-2-3	11-7	460	8 X 1/2	7-10	470
7274-2-5	11-8	210	8 X 1/2	7-22	290
7274-2-5	11-7	450	8 X 3/8	7-7	30
7277-5-2	11-9	115	8 X 3/8	7-22	300
7277-5-3	11-9	110	8000 B.786	11-5	50
7277-5-5	11-9	120	8000 B.852	11-7	400
7304DT	12-10	40	8000 B.853	11-8	185
7304DT	12-11	270	8000 B.853	11-9	95
732BL	11-8	–	8000 CODE B251	11-3	60
732BL	11-8	–	8000-B.852	11-5	50
732RTV	7-20	–	8000-B.853	11-5	50A
732-RTV	3-16	30	8000-B160	11-2	60
7361	5-4	80	8000-B160	11-5	50
74465	3-30	90	8000-B251	11-4	–60A
748-RTV	11-19	–	8000-B251	11-5	50B
75118	3-27	80	8000-B251	11-6	30
75386	3-22	470	8000-B332	11-2	–60A
755-2-2-6	10-1	6	8000T	11-1	170
755-2-2-6	10-2	6	8000T	11-4	60

ENSTROM F-28/280 SERIES ILLUSTRATED PARTS CATALOG

PART NUMBER INDEX SECTIONS 3 THROUGH 7 AND 9 THROUGH 12 FIGURES 8-1 THROUGH 8-11

Part Number	Figure	Item	Part Number	Figure	Item
800-28V-BAT	11-8	100	82-19-160-16	7-18	-
803-1710-0331-5	11-3	-	82-32-101-17	7-1	-
803-1710-0331-504	6-11	190	82-32-101-20	3-20	-
803-1710-0331-504	11-1	-	82-32-101-20	3-20	-
803-1710-0331-504	11-4	-	82-32-101-20	3-20A	-
803-1710-0331-504	11-5	-	82-32-101-20	3-20A	-
804-1710-0332-5	11-3	-	82-32-101-20	3-20B	-
804-1710-0332-504	11-1	-	82-32-101-20	3-20B	-
804-1710-0332-504	11-4	240	82-32-101-20	7-8	250
804-1710-0332-504	11-5	-	82-32-101-20	7-18	-
8110-CC	3-22	150	82-32-101-20	7-18	-
8134K21A1M50	11-4	20	82-32-101-20	7-18	-
8134K21A1M52	11-1	130	82-32-101-20	7-18	-
8134K21A1T50	11-1	10	82-35-302-15	3-18	-
8134K21A1T50	11-4	10	82-35-302-15	3-18	-
8190002	3-22	370	82-35-302-15	3-18	-
8190042	3-23	370	82-35-302-15	3-20	-
82-11-120-16	7-9	420	82-35-302-15	3-20	-
82-11-120-16	7-11	340	82-35-302-15	3-20	-
82-12-120-16	7-1	580	82-35-302-15	3-20	-
82-12-120-16	7-8	230	82-35-302-15	3-20	-
82-12-120-16	7-11	370	82-35-302-15	3-20	-
8-218-N300-9	7-21	170	82-35-302-15	3-20	-
82-19-120-16	3-20	-	82-35-302-15	3-20A	-
82-19-120-16	3-20	-	82-35-302-15	3-20A	-
82-19-120-16	3-20A	-	82-35-302-15	3-20A	-
82-19-120-16	3-20A	-	82-35-302-15	3-20A	-
82-19-120-16	3-20B	-	82-35-302-15	3-20A	-
82-19-120-16	3-20B	-	82-35-302-15	3-20A	-
82-19-140-16	3-20	-	82-35-302-15	3-20A	-
82-19-140-16	3-20	-	82-35-302-15	3-20B	-
82-19-140-16	3-20A	-	82-35-302-15	3-20B	-
82-19-140-16	3-20A	-	82-35-302-15	3-20B	-
82-19-140-16	3-20B	-	82-35-302-15	3-20B	-
82-19-140-16	3-20B	-	82-35-302-15	3-20B	-
82-19-160-16	7-18-	-	82-35-302-15	3-20B	-
82-19-160-16	7-18	-	82-35-302-15	3-20B	-
82-19-160-16	7-18	-	82-35-302-15	7-1	590

ENSTROM F-28/280 SERIES ILLUSTRATED PARTS CATALOG

PART NUMBER INDEX SECTIONS 3 THROUGH 7 AND 9 THROUGH 12 FIGURES 8-1 THROUGH 8-11

Part Number	Figure	Item	Part Number	Figure	Item
82-46-101-39	7-1	–	980-001	6-6	200
82-46-101-39	7-8	260	980-001	11-20	90
82-46-101-39	7-18	–	980-001	7-8	300
82-46-101-39	7-18	–	980-001	7-9	360
82-46-101-39	7-18	–	980-003	7-8	170
82-46-101-39	7-18	–	A005-1991	12-2	120
8-32X1/4 IN	7-5	530	A01784-6Z-1D	3-17	20
8473 H5L16	5-6	–	A01787-8Z-1D	7-7	40
8473H5L16	5-7	90	A01787-8Z-1D	7-10	490
8473RUPH5-L16	5-6	–	A01789-8Z1D	7-22	280
848-FSO-10-08	3-7	10	A01789-8Z-1D	3-20	292
848-FSO-10-08	3-7	320	A01789-8Z-1D	7-10	530
849-FSO-06-08	3-23	220	A06191-8Z-1D	6-12	40
85-140-16	7-11	380	A06191-8Z-1D	7-10	480
85-34-101-17	7-1	–	A06195-8Z-1D	7-10	630
85-46-101-39	7-1	–	A-10019-D	3-23	140
85-9217-06	3-30	40A	A-10019-E	3-23	140
883-FS-06X04	3-4	120	A10K166	7-6	650
8x1/2	10-1	17	A-1280-1	6-6	60
8x1/2	10-2	9	A-1280-2	6-6	30
8X1/2	3-17	90	A-1280-3	6-6	30
8x1/2	9-1	15	A1285-C-12	6-4	80
8x1/2	9-3	–	A1285-G-12	6-4	20
8x1/2	9-4	–	A-1285-G-12	6-6	20B
8x3/4	9-2	7	A1285-R-12	6-4	10
8X3/8	6-5	255	A-1285-R-12	6-6	20A
8x3/8	9-3	20	A1784-6Z-1	3-17	20
8x3/8	9-3	20A	A1784-6Z-1	9-1	10
8x3/8	9-4	–	A1785-6Z1D	7-5	630
8x3/8	9-4	–	A1787-8Z-1	9-1	4
8X5/8	3-20	291	A1787-8Z-1	7-22	280
951789	3-23	660	A1789-8Z1	10-1	8
959-3	12-12	30	A1789-8Z1	10-2	8
959-5	4-4	130	A1789-8Z1	10-3	–
96394-01	3-30	–A	A1789-8Z1	10-4	150
97CSX-2 24VDC	6-7	190	A2037	12-11	110
980-001	3-2	270	A2126	12-11	100
980-001	4-2	–	A-218-938517-00	8-5	–180F

ENSTROM F-28/280 SERIES ILLUSTRATED PARTS CATALOG

PART NUMBER INDEX SECTIONS 3 THROUGH 7 AND 9 THROUGH 12 FIGURES 8-1 THROUGH 8-11

Part Number	Figure	Item	Part Number	Figure	Item
A350CNIWBKSH28	11-8	80	AA8131	6-12	120
A350CNIWBKSH28	11-7	180	AA-832-06	11-8	485
A413A,HDA,DF	6-6	150	AA86146	5-6	170
A421-1	11-21	1260	AA-ECD-084-280	4-2.1	50
A-440	6-6	100	ABEC-3	12-9	160
A457A	6-6	430	ABM1M-A-C	11-19	120
A469	6-6	360	ABM1M-A-C	6-12	90
A470-R	6-6	230	ABM1M-A-C	6-2	-
A490T-DF14	6-6	150A	AC78M	6-9	10
A490T-DF28	6-6	150B	ACF-50	4-2	-
A508-14	6-6	140	AD43BSLF	7-5	50
A508-14	6-6	440	AD44BSLF	7-5	-60
A508-28	6-6	140	AD45BSLF	7-5	-70
A53C	3-1	30	AE80664H	3-3	-
A53C	3-2	30	AEROSHELL 22	5-2	-
A555-H	6-6	420	AFP5	3-1	30
A610	6-6	130	AFP5	3-2	30
A612	6-6	400	AJ4-30	7-9	160
A615	6-6	410	AJ4-35	7-1	530
A6195-8Z1D	9-4	-	AJW4-30	3-2	111
A6195-8Z-1D	9-4	-	AJW4-30	3-20	-
A-740-12	10-1	19	AJW4-30	3-20	-
A-740-12	10-2	21	AJW4-30	3-20A	-
A-740-12	10-3	14	AJW4-30	3-20A	-
A-740-12	10-4	220	AJW4-30	3-20B	-
A-8110-G	3-22	150	AJW4-30	3-20B	-
A8943-632-493	11-6	70	AJW4-30	3-20B	-
A8944-632-493	11-6	150	AJW4-30	3-20B	-
A8970B-1-330	11-1	390	ALJF3T	7-6	520
A8970B-1-330	11-2	290	ALJFL3T	7-6	450
A8970B-1-330	11-3	290	ALU8521LS	3-31	-
A8970B-1-330	11-4	280	AN100C-4	12-5	790
A8970B-1-330	11-5	-	AN173-17A	3-11	70
A8970B-1-330	11-6	180	AN173-21A	3-11	80
A-8970B-1-330	6-4	350	AN174-21	8-4	280
AA-2204	6-12	80	AN176-15A	4-2	290
AA-28-14385-15	4-2.1	10A	AN176-17A	4-2	300
AA-28-14386-1	4-2.1	40A	AN178-21	4-3	130

ENSTROM F-28/280 SERIES ILLUSTRATED PARTS CATALOG

PART NUMBER INDEX SECTIONS 3 THROUGH 7 AND 9 THROUGH 12 FIGURES 8-1 THROUGH 8-11

Part Number	Figure	Item	Part Number	Figure	Item
AN178H-65A	5-4	150	AN315-3L	7-6	440
AN178H-66A	5-4	150	AN315-3R	3-10	270
AN178H-67A	5-4	150	AN315-3R	3-14	40
AN178H-70A	5-4	150	AN315-3R	3-15	40
AN210-1B	12-5	890	AN315-3R	3-28	230
AN210-2B	12-5	870	AN315-3R	3-28	280
AN210-3B	12-5	880	AN315-3R	3-28	280
AN2552-3A	6-13	120	AN315-3R	3-28	280
AN3-10	3-10	280	AN315-3R	3-28	280
AN310-5	3-28	380	AN315-3R	7-6	530
AN310-7	3-30	50A	AN315-3R	7-5	390
AN3-10A	3-10	140	AN315-4R	6-2	–
AN3-10A	3-11	130	AN315-4R	6-2	–
AN3-10A	8-11	50	AN315-4R	6-2	–
AN3-11	3-28	330	AN316-12	3-24	460
AN3-11A	11-18	5	AN316-12R	3-15	80
AN3-11A	12-4	280	AN316-12R	3-24	460
AN3-11A	3-23	550	AN316-12R	5-3	480
AN3-11A	3-6	150	AN316-3R	3-14	40
AN3-11A	3-7	120	AN316-3R	3-15	40
AN3-11A	5-3	190	AN316-4L	8-11	210
AN3-12	3-11	460	AN316-4R	3-11	–
AN3-12A	11-9	210	AN316-4R	3-11	190
AN3-12A	3-10	210	AN316-4R	8-11	210
AN3-12A	3-13	70	AN316-5	8-3	150
AN3-12A	4-2	425	AN316-5	8-5	–
AN3-12A	4-2.1	130	AN316-5L	12-6	150
AN3-12A	5-5	250	AN316-5L	5-5	210
AN3-12A	11-7	610	AN316-5L	8-4	120
AN3-13	3-11	420	AN316-5L	8-5	–
AN3-13	3-14	70	AN316-5L	12-5	190
AN3-13A	3-10	170	AN316-5R	12-6	170
AN3-13A	3-12	110	AN316-5R	5-2	160
AN3-13A	3-13	40	AN316-5R	5-5	190
AN3-13A	3-26	200	AN316-5R	8-3	150
AN3-14A	3-23	560	AN316-5R	8-4	110
AN3-14A	6-13	30	AN316-5R	8-6A	120
AN3-14A	8-5A	140	AN316-5R	12-5	310

ENSTROM F-28/280 SERIES ILLUSTRATED PARTS CATALOG

PART NUMBER INDEX SECTIONS 3 THROUGH 7 AND 9 THROUGH 12 FIGURES 8-1 THROUGH 8-11

Part Number	Figure	Item	Part Number	Figure	Item
AN316-6R	5-6	–	AN340-6	3-16	110
AN316-6R	6-11	30	AN340-6	3-26	120
AN316-7R	3-14	90	AN340-6	11-20	80
AN316-7R	3-15	100	AN340-6	7-1	–
AN316-8R	3-14	90	AN340-632	3-20	370
AN316-8R	3-15	100	AN340-632	3-20A	370
AN316-8R	5-3	500	AN340-632	3-20B	370
AN3-16A	8-11	90	AN340-632	11-5	–
AN3-16A	7-15	280	AN340-632	11-6	80
AN3-16A	7-16	30	AN340-8	10-3	–
AN3-16A	7-17	260	AN340-8	10-4	210
AN3-17A	8-5	310	AN340-8	3-2	250
AN3-17A	8-7	50	AN340-8	3-20	600
AN3-17A	7-15	100	AN340-8	3-20A	600
AN3-17A	7-16	40	AN340-8	3-20B	600
AN3-17A	7-17	310	AN340-8	3-22	130
AN320-6	8-1	150	AN340-8	3-23	110
AN320-7	8-1	120	AN340-8	3-24	140
AN320-8	5-3	90	AN340-8	3-4	310
AN320-8	8-3A	400	AN340-8	3-5	80
AN3-20A	7-15	50	AN340-8	3-6	120
AN3-20A	7-17	140	AN340-8	3-7	80
AN3-21A	9-5	60	AN340-8	5-1	370
AN3-22	3-11	380	AN340-8	6-1	–
AN3-22A	5-1	120	AN340-8	6-1	–
AN3-22A	8-11	300	AN340-8	6-1	–
AN3-23A	3-12	90	AN340-8	6-1	–
AN3-27A	7-20	140	AN340-8	6-13	–
AN3-3A	3-20	450	AN340-8	6-2	–
AN3-3A	3-20A	450	AN340-8	9-1	8
AN3-3A	3-20B	450	AN340-8	9-2	14
AN3-3A	3-22	20	AN340-8	11-13	110
AN3-3A	6-2	–	AN340-8	11-14	140
AN3-3A	6-2	–	AN340-8	11-16	80
AN3-3A	6-3	20	AN340-832	11-18	50
AN3-3A	8-5	240	AN340-832	12-4	120
AN340-4	8-9	90	AN340-832	3-2	250
AN340-4	8-10	90	AN340-832	3-4	310

ENSTROM F-28/280 SERIES ILLUSTRATED PARTS CATALOG

PART NUMBER INDEX SECTIONS 3 THROUGH 7 AND 9 THROUGH 12 FIGURES 8-1 THROUGH 8-11

Part Number	Figure	Item	Part Number	Figure	Item
AN340-832	3-9	120	AN3-5A	3-7	330
AN340-832	8-3A	290	AN3-5A	5-5	310
AN340-832	11-17	180	AN3-5A	7-5	870
AN340-832	7-1	700	AN3-5A	7-9	90
AN340-832	7-2	130	AN3-5A	7-15	240
AN341-516	6-13	–	AN3-5A	7-16	150
AN345-10	3-1	90	AN3-6	12-7	190
AN345-10	3-20	595	AN3-6	3-13	90
AN345-10	3-20B	595	AN363-524	3-3	180
AN345-10	3-25	50	AN364-1018A	5-6	20
AN345-10	6-13	–	AN364-1032	8-5	260
AN345-10	8-9	–	AN364-1032	8-5A	160
AN345-10	8-10	–	AN364-1032	8-6	60
AN345-1032	7-5	750	AN364-1032	8-7	70
AN3-4A	3-10	30	AN364-1032A	3-10	190
AN3-4A	3-12	20	AN364-1032A	3-11	160
AN3-4A	3-20	470	AN364-1032A	3-13	60
AN3-4A	3-20A	470	AN364-1032A	3-21	50
AN3-4A	3-20B	–	AN364-1032A	3-26	220
AN3-4A	3-20B	470	AN364-1032A	5-1	150
AN3-4A	3-23	20	AN364-1032A	5-3	460
AN3-4A	3-6	250	AN364-1032A	5-5	300
AN3-4A	3-7	150	AN364-1032A	6-13	–
AN3-4A	3-7	250	AN364-1032A	6-13	–
AN3-4A	6-13	186	AN364-1032A	6-13	–
AN3-4A	6-13	260	AN364-1032A	6-13	188
AN3-4A	9-5	40	AN364-1032A	6-13	195
AN3-4A	8-6	40	AN364-1032A	6-14	130
AN3-4A	8-6A	130	AN364-1032A	6-3	40
AN3-4A	7-9	380	AN364-1032A	8-11	70
AN3-4A	7-10	650	AN364-1032A	8-6A	150
AN3-5	3-10	230	AN364-1032A	7-1	–
AN3-5A	12-3	70	AN364-1032A	7-3	70
AN3-5A	3-12	70	AN364-1032A	7-9	140
AN3-5A	3-20	500	AN364-1032A	7-17	110
AN3-5A	3-20A	500	AN364-1216A	4-2	270
AN3-5A	3-20B	500	AN364-1216A	7-20	560
AN3-5A	3-21	20	AN364-428	8-8	60

ENSTROM F-28/280 SERIES ILLUSTRATED PARTS CATALOG

PART NUMBER INDEX SECTIONS 3 THROUGH 7 AND 9 THROUGH 12 FIGURES 8-1 THROUGH 8-11

Part Number	Figure	Item	Part Number	Figure	Item
AN364-428A	3-22	180	AN364-832A	10-3	–
AN364-428A	3-22	290	AN364-832A	10-3	–
AN364-428A	3-23	190	AN364-832A	10-3	–
AN364-428A	5-1	490	AN364-832A	10-3	–
AN364-428A	5-1	70	AN364-832A	10-4	270
AN364-428A	5-5	140	AN364-832A	10-4	410
AN364-428A	6-13	–	AN364-832A	10-4	90
AN364-428A	7-17	360	AN364-832A	11-19	228
AN364-428A	8-11	10	AN364-832A	3-2	190
AN364-428A	8-11	150	AN364-832A	6-6	340
AN364-428A	12-13	300	AN364-832A	6-7	110
AN364-428A	12-10	160	AN364-832A	6-7	210
AN364-428A	12-11	230	AN364-832A	9-2	32
AN364-428A	12-12	270	AN364-832A	9-3	410
AN364-524A	5-4	230	AN364-832A	11-11	200
AN364-524A	7-20	–	AN364-832A	7-5	200
AN364-524A	7-21	30	AN364-832A	7-11	470
AN364-624A	4-2	320	AN364-W33A	7-9	390
AN364-624A	5-3	330	AN365-1032A	11-18	10
AN364-624A	7-19	40	AN365-1032A	12-2	80
AN364-632A	6-14	40	AN365-1032A	3-10	160
AN364-632A	6-4	–	AN365-1032A	3-10	40
AN364-632A	6-4	–	AN365-1032A	3-11	100
AN364-632A	6-4	–	AN365-1032A	3-12	50
AN364-632A	6-4	–	AN365-1032A	3-20	520
AN364-632A	6-4	–	AN365-1032A	3-20A	520
AN364-632A	6-4	–	AN365-1032A	3-20B	520
AN364-632A	6-6	190	AN365-1032A	3-23	580
AN364-632A	9-2	41	AN365-1032A	3-6	170
AN364-632A	12-13	330	AN365-1032A	3-6	270
AN364-632A	7-1	–	AN365-1032A	3-7	140
AN364-632A	7-11	440	AN365-1032A	5-3	220
AN364-632A	12-11	50	AN365-1032A	5-6	–
AN364-632A	12-12	300	AN365-1032A	6-13	61
AN364-820A	5-3	130	AN365-1032A	11-11	90
AN364-820A	5-4	120	AN365-1032A	7-9	110
AN364-832	6-5	32	AN365-1032A	7-9	350
AN364-832	9-3	360	AN365-1032A	7-15	70

ENSTROM F-28/280 SERIES ILLUSTRATED PARTS CATALOG

PART NUMBER INDEX SECTIONS 3 THROUGH 7 AND 9 THROUGH 12 FIGURES 8-1 THROUGH 8-11

Part Number	Figure	Item	Part Number	Figure	Item
AN365-1032A	7-16	60	AN365-832A	3-10	100
AN365-1032A	7-17	160	AN365-832A	3-2	190
AN365-1032A	7-20	160	AN365-832A	6-11	221
AN365-1032C	3-27	70	AN365-832A	8-6	120
AN365-1032C	3-28	110	AN365-832A	8-6A	60
AN365-1032C	3-28	110	AN365-832A	7-5	380
AN365-1032C	3-28	50	AN365-832A	7-8	50
AN365-425	7-22	90	AN365-832A	7-9	320
AN365-428	5-6	310	AN3-6A	3-21	20
AN365-428	5-7	80	AN3-6A	3-3	–
AN365-428A	12-2	110	AN3-6A	6-13	–
AN365-428A	5-4	410	AN3-6A	7-10	–620
AN365-428A	6-2	–	AN3-7	3-10	330
AN365-428A	7-5	890	AN3-7	3-14	10
AN365-428A	7-15	190	AN3-7	3-15	10
AN365-428A	7-16	220	AN380-2-2	10-1	11
AN365-428A	7-17	250	AN380-2-2	10-2	12
AN365-428A	7-19	100	AN380-4-8	4-2	200
AN365-428A	7-20	120	AN381-2-10	12-8	250
AN365-524A	4-1	140	AN381-2-10	5-1	300
AN365-524A	7-19	70	AN381-2-10	7-6	70
AN365-524A	7-20	70	AN381-2-10	8-3	50
AN365-624A	5-4	380	AN381-2-10	8-5	470
AN365-632A	3-17	130	AN381-2-10	8-5	470
AN365-632A	6-11	–	AN381-2-12	3-24	530
AN365-632A	6-6	260	AN381-2-16	12-8	90
AN365-632A	9-3	110	AN381-2-7	8-2	70
AN365-632A	9-4	100	AN381-2-7	8-3A	370
AN365-632A	7-8	150	AN381-2-7	8-4	300
AN365-632A	7-9	70	AN381-2-7	7-5	280
AN365-632A	7-21	280	AN381-2-8	10-3	–
AN365-8	10-1	–	AN381-2-8	10-4	170
AN365-832	10-2	–	AN381-2-8	12-6	100
AN365-832	7-1	80	AN381-2-8	12-6	210
AN365-832	7-1	–	AN381-2-8	12-7	250
AN365-832	7-1	–	AN381-2-8	3-10	250
AN365-832	7-1	670	AN381-2-8	3-11	320
AN365-832	7-4	150	AN381-2-8	3-13	110
			AN381-2-8	3-14	60

ENSTROM F-28/280 SERIES ILLUSTRATED PARTS CATALOG

PART NUMBER INDEX SECTIONS 3 THROUGH 7 AND 9 THROUGH 12 FIGURES 8-1 THROUGH 8-11

Part Number	Figure	Item	Part Number	Figure	Item
AN381-2-8	3-15	60	AN4-12A	5-5	100
AN381-2-8	3-28	320	AN4-12A	8-8	30
AN381-2-8	5-2	110	AN4-13	12-6	10
AN381-2-8	5-3	410	AN4-13	12-10	250
AN381-2-8	5-5	170	AN4-13A	3-22	270
AN381-2-8	8-3	100	AN4-13A	3-23	290
AN381-2-8	8-4	190	AN4-13A	5-5	350
AN381-2-8	8-5	420	AN4-14	12-6	190
AN381-2-8	8-5A	130	AN4-14	5-1	260
AN381-2-8	8-6A	200	AN4-14	5-3	550
AN381-2-8	12-10	210	AN4-14	8-3	70
AN381-3-12	8-5A	80	AN4-14A	7-13	50
AN381-3-16	4-3	170	AN4-14A	7-19	80
AN381-3-16	8-1	140	AN4-14A	7-20	290
AN381-3-16	8-3A	410	AN4-15A	5-1	10
AN386-2-7A	12-2	60	AN4-16	3-11	330
AN386-2-7A	5-6	-	AN416-1	12-5	110
AN386-2-8A	12-2	50	AN4-17	8-5	370
AN393-11	3-28	300	AN4-17A	5-6	290
AN393-11	7-5	270	AN4-17A	5-7	60
AN394-17	5-5	150	AN4-17A	8-8	110
AN3C10A	3-29	100	AN4-20A	7-15	270
AN3C4A	3-27	60	AN4-20A	7-16	200
AN3C4A	3-28	100	AN4-20A	7-17	230
AN3C4A	3-28	100	AN4-21A	7-15	170
AN3C4A	3-28	40	AN4-21A	7-16	110
AN3H3A	12-1	240	AN4-22A	7-15	260
AN3H5A	12-3	70A	AN4-22A	7-17	280
AN3H-5A	5-3	450	AN4-23	8-3A	310
AN3H6A	5-3	450	AN4-23A	5-1	220
AN4076-1	11-19	130	AN426A3-3	3-19	-
AN4076-1	5-6	160	AN4-27A	7-20	550
AN4-10A	8-11	130	AN42B-14	7-1	-
AN4-10A	8-8	70	AN42B-C11A	7-3	50
AN4-11	5-3	360	AN42B-C12A	7-3	50
AN4-11	8-4	230	AN42B-C14A	7-3	50
AN4-11A	7-17	340	AN4-30A	7-20	100
AN4-11A	8-8	140	AN4-31A	7-22	70

ENSTROM F-28/280 SERIES ILLUSTRATED PARTS CATALOG

PART NUMBER INDEX SECTIONS 3 THROUGH 7 AND 9 THROUGH 12 FIGURES 8-1 THROUGH 8-11

Part Number	Figure	Item	Part Number	Figure	Item
AN4-34A	7-20	240	AN502-10-10	7-16	240
AN4-37	3-11	270	AN502-10-14	3-28	220
AN4-37A	7-20	270	AN502-10-8	3-20	400
AN4-3A	3-22	160	AN502-10-8	3-20A	400
AN4-3A	3-23	180	AN502-10-8	3-20B	400
AN4-3A	6-13	180	AN502-10-8	3-9	130
AN4-3A	6-2	–	AN502-10-8	8-9	–
AN4-3A	6-2	–	AN502-10-8	8-10	–
AN4-3A	6-2	–	AN503-10-10	8-2	10
AN4-3A	6-2	–	AN503-10-10	8-3A	170
AN4-4A	5-6	220	AN503-10-18	12-8	260
AN4-4A	7-13	30	AN503-10-18	12-5	690
AN4-4A	12-10	180	AN503-10-6	5-2	50
AN4-5A	5-3	150	AN503-10-8	12-7	240
AN4-5A	12-13	280	AN503-10-8	3-3	210
AN4-5A	12-12	250	AN503-416-10	3-20	530
AN4-6A	5-1	470	AN503-416-10	3-20	530
AN4-6A	9-5	10	AN503-416-10	3-20A	530
AN4-7A	12-2	90	AN503-416-10	3-20B	530
AN4-7A	5-4	390	AN503-416-10	3-20B	530
AN4-7A	7-5	950	AN503-416-10	3-4	40
AN4-7A	7-13	10	AN503-416-28	3-20	530
AN4C5A	3-29	60	AN503-416-28	3-20A	530
AN4H10A	4-4	170	AN503-416-28	3-20B	530
AN4H-12A	3-11	260	AN503-416-28	3-7	360
AN4H15A	4-4	280	AN503-8-6	8-7	–
AN4H4A	12-13	270	AN503-8-6	8-10	380
AN4H-4A	12-9	120	AN503-8-8	8-9	130
AN4H-4A	12-11	170	AN503-8-8	8-9	380
AN4H-4A	12-12	240	AN503-8-8	8-10	130
AN4H-5A	12-10	300	AN507-1032-8	7-5	460
AN4H-5A	12-11	210	AN507-1032R14	6-13	130
AN500-416-7	3-23	160	AN507-632-5	7-1	500
AN500-6-8	3-26	110	AN507-632R12	6-4	100
AN502-10-10	8-3A	260	AN507-632R14	6-6	170
AN502-10-10	8-9	20	AN507-632R24	6-6	160
AN502-10-10	8-10	20	AN507-632R5	7-11	420
AN502-10-10	7-15	140	AN507-632R8	6-4	50

ENSTROM F-28/280 SERIES ILLUSTRATED PARTS CATALOG

PART NUMBER INDEX SECTIONS 3 THROUGH 7 AND 9 THROUGH 12 FIGURES 8-1 THROUGH 8-11

Part Number	Figure	Item	Part Number	Figure	Item
AN507-632R8	6-6	210	AN515-6R7	3-17	110
AN507-632R8	6-6	380	AN515-6R8	3-26	110
AN507-832-16	6-9	50	AN515-8-10	6-1	130
AN507-832R10	11-20	120	AN515-8-10	6-1	70
AN507-832R7	7-2	100	AN515-8-10	11-14	–
AN507-832R9	7-1	680	AN515-8-16	3-22	100
AN507-8R9	7-4	110	AN515-8-16	11-14	110
AN507-B-632-R6	11-6	430	AN515-8-16	12-9	210
AN507C1032-12	7-1	820	AN515-8-20	11-14	170
AN507C-1032-12	7-1	–	AN515-8-24	11-14	–
AN507C-632-8	7-1	300	AN515-8-7	10-1	20
AN507C-832-12	7-1	280	AN515-8-7	10-2	22
AN509-10R16	6-13	192	AN515-8-8	3-2	230
AN509-10R38	3-12	80	AN515-8-8	6-1	110
AN509-832R4	6-11	240	AN515-8-8	6-1	50
AN509-8R10	7-4	140	AN515-8-8	11-14	160
AN509-8R12	7-1	870	AN515-8R10	3-22	400
AN509-8R16	7-4	280	AN515-8R10	3-23	80
AN509-8R18	7-1	60	AN515-8R10	3-24	240
AN5-10	8-5	430	AN515-8R10	3-4	280
AN5-11	8-4	200	AN515-8R10	3-5	50
AN5-11	8-5	520	AN515-8R10	3-6	90
AN5-11	8-6A	160	AN515-8R10	3-7	50
AN5-11A	3-3	170	AN515-8R10	11-13	100
AN5-12	8-3	20	AN515-8R10	11-16	120
AN5-12	8-5	510	AN515-8R12	3-4	280
AN5-13	8-5A	90	AN515-8R14	6-11	60
AN515-10-16	12-10	280	AN515-8R16	3-22	100
AN515-10-6	3-1	60	AN515-8R16	11-13	150
AN515-4R12	8-9	60	AN515-8R20	3-24	250
AN515-4R12	8-10	60	AN515-8R7	10-3	–
AN515-6-6	3-20	340	AN515-8R7	10-3	7
AN515-6-6	3-20A	340	AN515-8R7	10-3	8
AN515-6-6	3-20B	340	AN515-8R7	3-17	140
AN515-6-6	6-4	260	AN515-8R7	3-20	430
AN515-6-6	6-4	300	AN515-8R7	3-20A	430
AN515-6-R11	6-5	190	AN515-8R7	3-20B	430
AN515-6R3	11-17	20	AN515-8R7	3-6	230

ENSTROM F-28/280 SERIES ILLUSTRATED PARTS CATALOG

PART NUMBER INDEX SECTIONS 3 THROUGH 7 AND 9 THROUGH 12 FIGURES 8-1 THROUGH 8-11

Part Number	Figure	Item	Part Number	Figure	Item
AN515-8R7	3-7	250	AN520-832R8	7-10	270
AN515-8R7	3-7	280	AN5-22	5-1	400
AN515-8R8	10-2	-	AN5-22A	7-20	420
AN515-8R8	10-3	-	AN525-1032-8	7-9	330
AN515-8R8	10-4	180	AN525-1032R12	7-17	90
AN515-8R8	10-4	230	AN525-10R10	7-6	360
AN515-8R8	10-4	50	AN525-10R24	6-13	70
AN515-8R8	12-4	90	AN525-10R8	7-10	590
AN515-8R8	3-19	140	AN525-832-18	7-1	640
AN515-8R8	3-2	260	AN525-832R10	11-19	185
AN515-8R8	3-20	570	AN525-832R10	9-2	30
AN515-8R8	3-20A	570	AN525-832R10	9-3	370
AN515-8R8	3-20B	570	AN525-832R10	7-5	450
AN515-8R8	3-24	130	AN525-832R10	7-10	70
AN515-8R8	11-17	150	AN525-832R10	7-12	50
AN515-8R8	7-9	300	AN525-832R14	6-11	150
AN515-8R8	7-9	400	AN525-832R14	9-3	370A
AN515-8-R8	11-18	40	AN525-832R18	3-24	250
AN515-8R8-832	3-2	230	AN525-832R22	3-25	90
AN515B-6-R12	11-6	50	AN525-832R6	3-1	160
AN515B-6-R14	11-5	-	AN525-832R6	6-5	220
AN515B-6-R14	11-6	140	AN525-832R6	7-6	260
AN515B-6-R16	11-6	60	AN525-832R6	8-6A	40
AN515B-6-R18	11-6	130	AN525-832R6	7-1	440
AN515-B6R3	11-8	130	AN525-832R6	7-8	110
AN515-B6R3	11-9	-	AN525-832R7	7-1	410
AN515-B6R3	11-7	330	AN525-832R7	7-5	600
AN515B-6-R6	11-6	220	AN525-832R7	7-11	450
AN515B-6-R7	11-6	380	AN525-832R8	11-19	205
AN515B-8-R12	11-8	515	AN525-832R8	3-23	50
AN5-16	8-4	140	AN525-832R8	3-25	20
AN517-8R7	3-9	90	AN525-832R8	6-10	60
AN5-17A	7-20	400	AN525-832R8	11-11	180
AN520-10-16	12-11	310	AN525-832R8	11-16	60
AN520-10-16	12-12	230	AN525-832R8	7-5	180
AN520-10-40	12-11	340	AN525-832R8	7-5	310
AN520-10-40	12-12	330	AN525-832R8	7-5	820
AN520-10-9	7-9	120	AN525-832R8	7-8	30

ENSTROM F-28/280 SERIES ILLUSTRATED PARTS CATALOG

PART NUMBER INDEX SECTIONS 3 THROUGH 7 AND 9 THROUGH 12 FIGURES 8-1 THROUGH 8-11

Part Number	Figure	Item	Part Number	Figure	Item
AN525-832R8	7-10	100	AN526-6R6	3-16	80
AN525-832R8	7-12	40	AN526-6R8	7-3	130
AN525-832R8	7-15	120	AN526-6R8	7-4	360
AN525-832R8	7-16	260	AN526-832-5	3-2	260
AN525-8R16	7-4	180	AN526-832-8	7-8	180
AN525-8R20	6-5	30	AN526-832R10	6-11	210
AN525-8R6	5-1	340	AN526-832R10	6-5	240
AN525-8R7	7-9	-	AN526-832R10	6-7	30
AN525-8R8	7-8	320	AN526-832R10	7-12	50
AN526-1032-6	12-9	200	AN526-832R6	6-4	200
AN526-1032R6	6-14	110	AN526-832R7	10-4	300
AN526-1032R8	3-20	565	AN526-832R7	10-4	390
AN526-1032R8	3-20A	565	AN526-832R7	3-10	80
AN526-1032R8	3-20B	565	AN526-832R7	6-11	210
AN526-1032R8	3-20B	565	AN526-832R8	10-3	12
AN526-1032R8	3-5A	150	AN526-832R8	11-19	226
AN526-1032R8	6-13	-	AN526-832R8	3-2	120
AN526-1032R8	11-11	70	AN526-832R8	6-10	60
AN526-1032R8	7-5	510	AN526-832R8	6-13	250
AN526-632-5	7-1	-	AN526-832R8	6-5	210
AN526-632R10	9-2	39	AN526-832R8	6-5	40
AN526-632R12	11-19	45	AN526-832R8	6-6	320
AN526-632R16	6-5	-	AN526-832R8	6-7	90
AN526-632R16	6-5	-	AN526-832R8	6-8	40
AN526-632R4	5-4	340	AN526-832R8	9-1	6
AN526-632R5	6-14	20	AN526-832R8	9-2	12
AN526-632R6	6-6	250	AN526-832R8	9-3	270
AN526-632R6	11-20	40	AN526-832R8	9-4	240
AN526-632R6	7-9	50	AN526-832R8	7-5	180
AN526-632R7	6-4	130	AN526-832R8	7-8	30
AN526-632R7	6-6	280	AN526-832R8	7-12	40
AN526-632R7	11-20	50	AN526-832R8	7-15	320
AN526-632R8	6-4	170	AN526-832R8	7-16	70
AN526-632R8	6-4	280	AN526-832R8	7-17	120
AN526-632R8	6-6	310	AN526-832R9	6-5	245
AN526-632R8	6-6	370	AN526-8-8	7-1	230
AN526-632R8	6-7	160	AN526-8R12	7-4	60
AN526-632R8	7-1	-	AN526-8R7	3-10	80

ENSTROM F-28/280 SERIES ILLUSTRATED PARTS CATALOG

PART NUMBER INDEX SECTIONS 3 THROUGH 7 AND 9 THROUGH 12 FIGURES 8-1 THROUGH 8-11

Part Number	Figure	Item	Part Number	Figure	Item
AN526-8R8	9-3	330	AN5-44A	4-1	50
AN526C1032-9	7-3	90	AN5-4A	6-13	220
AN526-C1032-9	7-1	-	AN5546-1	11-19	135
AN526C832R8	3-22	50	AN5546-1	5-6	170
AN530-6-6	7-1	210	AN5-6A	7-20	60
AN530-6-8	9-3	40	AN5C13A	3-29	90
AN530-6-8	9-4	40	AN5H10A	7-13	60
AN530-6-8	7-1	-	AN5H-45A	4-1	20
AN530-6R6	3-17	30	AN5H-46A	4-1	20
AN530-6R6	3-17	60	AN5H-6A	4-1	10
AN530-6R6	7-5	860	AN5H7A	7-13	90
AN530-6R8	7-5	640	AN6-10A	5-4	360
AN530-8-7	7-1	-	AN6195-8Z-1D	9-3	-
AN530-8-8	10-1	7	AN6195-8Z-1D	9-3	-
AN530-8-8	10-2	7	AN6-22	8-5A	60
AN530-8R8	10-3	4	AN6227-6	5-6	-
AN530-8R8	10-4	130	AN635-632A	9-4	210
AN530-8R8	3-17	160	AN665-21R	7-5	400
AN530-8R8	3-17	180	AN665-46R	5-5	180
AN530-8R8	9-1	3	AN737TW22	3-3	320
AN530-8R8	9-3	530	AN737TW22	3-4	80
AN530-8R8	9-4	-	AN737TW34-38	3-3	130
AN530-8R8	7-9	210	AN73A3	5-3	430
AN530C10-8	3-28	-	AN742-40	10-1	-
AN530C8-8	3-27	-	AN742D28	3-5A	90
AN531-6-6	7-5	590	AN742D28	3-5A	170
AN531-6R10	9-4	80	AN742D38	10-3	-
AN531-6R6	7-1	130	AN742D48	10-3	-
AN531-6R6	7-4	400	AN742D48	10-3	15
AN531-6R8	9-3	60	AN742D48	10-4	250
AN531-6R8	9-4	60	AN742D48	10-4	70
AN531-6R8	7-4	600	AN742D-48	3-1	40
AN5-35A	5-4	210	AN742-D48	10-2	28
AN5-35A	7-19	50	AN742-F6	3-20	620
AN5-35A	7-20	330	AN742-F6	3-20A	620
AN536-632R6	7-8	130	AN742-F6	3-20B	620
AN5-37A	7-20	300	AN742F8	5-5	290
AN5-43A	4-1	50	AN743-13	10-1	21

ENSTROM F-28/280 SERIES ILLUSTRATED PARTS CATALOG

PART NUMBER INDEX SECTIONS 3 THROUGH 7 AND 9 THROUGH 12 FIGURES 8-1 THROUGH 8-11

Part Number	Figure	Item	Part Number	Figure	Item
AN743-13	10-2	23	AN815-4D	11-9	270
AN743-13	10-3	17	AN815-4D	11-10	100
AN743-13	10-4	470	AN815-4D	11-12	40
AN743-13	11-15	110	AN815-4D	11-13	70
AN743-13	11-19	230	AN815-4D	11-15	60
AN743-13	3-24	-	AN815-6	3-23	-
AN743-13	3-24	-	AN815-6	3-6	70
AN743-13	3-24	-	AN815-6	3-8	80
AN743-13	3-24	320	AN816-4	3-4	190
AN743-13	11-11	100	AN816-4	3-8	40
AN743-13	11-13	140	AN816-4D	11-8	-
AN743-13	11-14	150	AN816-4D	11-8	-
AN74A11	3-3	50	AN816-4D	11-8	-
AN74A4	3-1	130	AN816-4D	11-8	-
AN74A4	3-2	290	AN816-4D	11-8	325
AN74A4	3-29	80	AN816-4D	11-9	255
AN74A5	3-3	110	AN816-4D	3-22	310
AN7-50	3-30	10A	AN816-4D	3-23	320
AN75A12	8-4	260	AN816-4D	3-24	350
AN75-A12	4-2	350	AN816-4D	3-24	80
AN75A41	3-23	460	AN816-4D	3-8	40
AN75A5	3-29	70	AN816-4D	11-7	730
AN75A5	3-3	20	AN816-4D	11-12	10
AN75A6	4-2	340	AN816-4D	11-12	130
AN75A6	8-4	250	AN816-4D	11-13	180
AN7H7A	12-13	350	AN816-6	3-22	230
AN7H-7A	12-9	10	AN816-6	3-23	400
AN7H-7A	12-11	10	AN816-6D	3-24	270
AN7H-7A	12-12	320	AN816-6D	5-6	110
AN8-10A	5-4	20	AN818-4D	11-15	-
AN814-2DL	12-1	70	AN818-4D	11-15	-
AN814-2DL	4-4	260	AN818-4D	11-15	-
AN815-4	3-22	440	AN818-4D	11-15	-
AN815-4	3-23	440	AN818-4D	11-15	-
AN815-4	11-11	150	AN818-4D	11-15	-
AN815-4D	3-4	170	AN818-4D	11-15	-
AN815-4D	11-7	690	AN818-4D	11-15	-
AN815-4D	11-8	340	AN818-4D	3-24	80

ENSTROM F-28/280 SERIES ILLUSTRATED PARTS CATALOG

PART NUMBER INDEX SECTIONS 3 THROUGH 7 AND 9 THROUGH 12 FIGURES 8-1 THROUGH 8-11

Part Number	Figure	Item	Part Number	Figure	Item
AN822-4D	3-24	350	AN924-4	3-24	190
AN822-4D	11-11	20	AN924-4	11-14	20
AN822-6D	3-26	180	AN924-4D	3-2	140
AN823-4D	3-24	350	AN924-4D	11-10	90
AN823-6-6D	3-6	20	AN924-4D	11-11	130
AN824-4D	11-12	30	AN924-4W	11-11	130
AN824-4D	11-15	55	AN924-6D	3-2	210
AN824-4D	3-24	100	AN931-10-14	7-8	330
AN824-4D	3-24	100	AN931-12-17	7-8	290
AN824-6D	3-4	100	AN931-12-20	3-23	490
AN832-4	3-24	180	AN931-2-9	3-22	490
AN832-4D	3-24	180	AN931-2-9	3-23	510
AN832-4D	11-10	70	AN931-3-10	6-4	290
AN832-4D	11-11	110	AN931-3-9	3-4	60
AN833-4	11-13	60	AN931-4-16	3-24	510
AN833-4	11-14	10	AN931-4-7	6-10	70
AN833-4D	11-15	15	AN931-4-7	6-11	180
AN834-4	3-24	380	AN931-4-7	6-7	220
AN834-4D	3-24	380	AN931-4-7	6-7	70
AN834-4D	11-11	40	AN931-4-7	11-16	90
AN900-10	5-6	120	AN931-4-7	11-17	80
AN900-6	5-6	140	AN931-5-12	3-2	170
AN900-8	5-6	120	AN931-5-9	3-10	50
AN911-1D	3-24	360	AN931-5-9	3-2	170
AN911-1D	11-13	190	AN931-6-10	3-15	140
AN911-4D	3-24	360	AN931-6-10	6-14	50
AN911-4D	11-12	120	AN931-6-10	11-17	60
AN914-1D	3-23	610	AN931-8-13	3-22	330
AN916-516L	8-6A	180	AN931-8-13	6-9	90
AN917-10	11-8	455	AN931-8-13	7-8	340
AN917-1D	11-7	970	AN932-D3	3-26	170
AN917-1D	11-9	365	AN935-10	3-1	80
AN917-1D	11-13	–	AN935-10	3-20	585
AN917-4D	11-12	50	AN935-10	3-20A	585
AN919-1	3-22	500	AN935-10	3-20B	585
AN919-1S	3-23	520	AN935-10	6-13	–
AN919-1S	11-10	40	AN935-10	8-9	–
AN924-4	11-15	25	AN935-10	8-10	–

ENSTROM F-28/280 SERIES ILLUSTRATED PARTS CATALOG

PART NUMBER INDEX SECTIONS 3 THROUGH 7 AND 9 THROUGH 12 FIGURES 8-1 THROUGH 8-11

Part Number	Figure	Item	Part Number	Figure	Item
AN935-10L	3-25	60	AN935-8	11-16	70
AN935-10L	7-5	660	AN935-8	11-17	170
AN935-4	8-9	80	AN935-8L	7-1	660
AN935-4	8-10	80	AN935-8L	7-2	120
AN935-416	5-6	230	AN935-BBL	11-8	510
AN935-6	3-16	100	AN936A10	3-20	410
AN935-6	3-20	360	AN936A10	3-20A	410
AN935-6	3-20A	360	AN936A10	3-20B	410
AN935-6	3-20B	360	AN936A1216	3-15	90
AN935-6	11-5	–	AN936A1216	3-24	450
AN935-6	11-6	90	AN936A516	3-24	70
AN935-6	11-20	70	AN936A516	3-24	70
AN935-6	7-1	–	AN936A516	3-3	300
AN935-8	10-2	–	AN936A516	6-13	–
AN935-8	10-3	–	AN936-A6	3-17	70
AN935-8	10-4	190	AN936-A6	6-6	270
AN935-8	11-18	55	AN936A716	3-14	100
AN935-8	12-4	110	AN936A716	3-15	110
AN935-8	3-2	240	AN936A8	9-3	300
AN935-8	3-20	590	AN936A8	9-4	260
AN935-8	3-20A	590	AN960-10	10-3	–
AN935-8	3-20B	590	AN960-10	11-18	15
AN935-8	3-22	120	AN960-10	12-4	270
AN935-8	3-23	100	AN960-10	3-11	400
AN935-8	3-24	150	AN960-10	3-11	90
AN935-8	3-4	300	AN960-10	3-12	30
AN935-8	3-5	70	AN960-10	3-20	510
AN935-8	3-6	110	AN960-10	3-20A	510
AN935-8	3-7	70	AN960-10	3-20B	510
AN935-8	3-9	110	AN960-10	3-21	30
AN935-8	5-1	350	AN960-10	3-21	40
AN935-8	6-1	–	AN960-10	3-23	30
AN935-8	6-1	–	AN960-10	3-23	570
AN935-8	6-1	–	AN960-10	3-6	160
AN935-8	6-1	–	AN960-10	3-7	130
AN935-8	6-13	–	AN960-10	4-2	–
AN935-8	11-13	130	AN960-10	4-2	430
AN935-8	11-14	130	AN960-10	4-2.1	140

ENSTROM F-28/280 SERIES ILLUSTRATED PARTS CATALOG

PART NUMBER INDEX SECTIONS 3 THROUGH 7 AND 9 THROUGH 12 FIGURES 8-1 THROUGH 8-11

Part Number	Figure	Item	Part Number	Figure	Item
AN960-10	5-1	450	AN960-10L	3-6	260
AN960-10	5-3	210	AN960-10L	3-7	160
AN960-10	6-13	–	AN960-10L	3-7	260
AN960-10	6-13	–	AN960-10L	4-2.1	150
AN960-10	6-13	193	AN960-10L	5-1	130
AN960-10	12-13	240	AN960-10L	5-2	60
AN960-10	8-9	30	AN960-10L	5-3	200
AN960-10	8-10	30	AN960-10L	5-3	440
AN960-10	7-3	100	AN960-10L	5-5	260
AN960-10	7-4	160	AN960-10L	6-13	–
AN960-10	7-5	580	AN960-10L	6-13	–
AN960-10	7-9	130	AN960-10L	6-13	187
AN960-10	7-15	110	AN960-10L	6-13	194
AN960-10	7-17	170	AN960-10L	6-13	40
AN960-10	7-20	150	AN960-10L	6-13	60
AN960-10	12-10	290	AN960-10L	6-14	120
AN960-10	12-11	320	AN960-10L	6-2	–
AN960-10	12-12	220	AN960-10L	6-3	30
AN960-10L	12-1	230	AN960-10L	8-3A	270
AN960-10L	12-7	200	AN960-10L	8-5	250
AN960-10L	12-8	270	AN960-10L	8-5A	150
AN960-10L	3-1	70	AN960-10L	12-13	–
AN960-10L	3-10	150	AN960-10L	8-6	50
AN960-10L	3-10	180	AN960-10L	8-6A	140
AN960-10L	3-12	40	AN960-10L	8-7	60
AN960-10L	3-13	50	AN960-10L	7-3	60
AN960-10L	3-14	20	AN960-10L	7-5	430
AN960-10L	3-15	20	AN960-10L	7-5	880
AN960-10L	3-20	460	AN960-10L	7-9	100
AN960-10L	3-20A	460	AN960-10L	7-15	60
AN960-10L	3-20B	460	AN960-10L	7-16	160
AN960-10L	3-21	30	AN960-10L	7-17	150
AN960-10L	3-21	40	AN960-1216	3-24	440
AN960-10L	3-22	30	AN960-1216L	3-10	110
AN960-10L	3-24	540	AN960-1216L	3-15	120
AN960-10L	3-25	70	AN960-3	3-20	–
AN960-10L	3-28	310	AN960-3	3-20A	–
AN960-10L	3-3	–	AN960-3	3-20B	–

ENSTROM F-28/280 SERIES ILLUSTRATED PARTS CATALOG

PART NUMBER INDEX SECTIONS 3 THROUGH 7 AND 9 THROUGH 12 FIGURES 8-1 THROUGH 8-11

Part Number	Figure	Item	Part Number	Figure	Item
AN960-3L	6-7	150	AN960-416L	3-29	120
AN960-4	7-1	800	AN960-416L	3-3	100
AN960-416	10-1	–	AN960-416L	3-4	50
AN960-416	12-6	60	AN960-416L	5-1	20
AN960-416	12-6	70	AN960-416L	5-5	110
AN960-416	3-11	350	AN960-416L	6-13	–
AN960-416	3-22	280	AN960-416L	8-11	140
AN960-416	3-23	300	AN960-416L	8-2	50
AN960-416	4-4	160	AN960-416L	8-4	240
AN960-416	5-1	280	AN960-416L	12-13	260
AN960-416	5-3	160	AN960-416L	8-8	40
AN960-416	5-3	390	AN960-416L	7-13	40
AN960-416	5-4	400	AN960-416L	7-15	180
AN960-416	5-5	330	AN960-416L	7-16	210
AN960-416	5-6	240	AN960-416L	7-17	240
AN960-416	8-3	80	AN960-416L	7-19	90
AN960-416	8-4	290	AN960-416L	7-20	110
AN960-416	8-5	380	AN960-416L	7-22	80
AN960-416	8-8	150	AN960-4L	10-3	–
AN960-416	7-5	900	AN960-4L	10-4	320
AN960-416	7-13	20	AN960-4L	8-9	70
AN960-416	12-9	130	AN960-4L	8-10	70
AN960-416	12-10	220	AN960-4L	7-2	160
AN960-416L	10-2	–	AN960-516	12-7	–55
AN960-416L	10-3	6	AN960-516	12-8	–230
AN960-416L	10-4	160	AN960-516	3-23	470
AN960-416L	3-1	140	AN960-516	3-23	470
AN960-416L	3-11	360	AN960-516	3-3	30
AN960-416L	3-2	300	AN960-516	4-1	60
AN960-416L	3-20	390	AN960-516	4-2	360
AN960-416L	3-20	540	AN960-516	5-1	420
AN960-416L	3-20A	390	AN960-516	5-2	90
AN960-416L	3-20A	540	AN960-516	5-4	220
AN960-416L	3-20B	390	AN960-516	8-3	30
AN960-416L	3-20B	540	AN960-516	8-4	170
AN960-416L	3-22	170	AN960-516	8-5	440
AN960-416L	3-22	170	AN960-516	8-6A	170
AN960-416L	3-23	170	AN960-516	7-13	70

ENSTROM F-28/280 SERIES ILLUSTRATED PARTS CATALOG

PART NUMBER INDEX SECTIONS 3 THROUGH 7 AND 9 THROUGH 12 FIGURES 8-1 THROUGH 8-11

Part Number	Figure	Item	Part Number	Figure	Item
AN960-516	7-19	60	AN960-6L	9-4	90
AN960-516L	12-7	50	AN960-6L	11-5	–
AN960-516L	12-8	220	AN960-6L	11-6	100
AN960-516L	3-29	130	AN960-6L	7-1	–
AN960-516L	4-2	360	AN960-6L	7-8	140
AN960-516L	5-1	410	AN960-6L	7-9	60
AN960-516L	6-13	–	AN960-716	3-2	150
AN960-516L	8-4	210	AN960-716	3-30	70
AN960-516L	8-5	450	AN960-716	11-10	80
AN960-516L	8-5A	100	AN960-716	11-11	120
AN960-516L	7-20	80	AN960-716	12-13	340
AN960-516L	7-20	–	AN960-716	12-9	20
AN960-516L	7-21	20	AN960-716	12-11	20
AN960-6	3-20	350	AN960-716	12-12	310
AN960-6	3-20A	350	AN960-716L	3-10	120
AN960-6	3-20B	350	AN960-716L	3-14	110
AN960-6	6-6	180	AN960-716L	3-15	130
AN960-6	7-21	270	AN960-716L	3-30	80
AN960-616	5-6	270	AN960-716L	8-1	100
AN960-616	7-19	30	AN960-8	10-1	–
AN960-616L	3-10	110	AN960-8	11-18	45
AN960-616L	5-4	370	AN960-8	12-4	100
AN960-616L	8-1	110	AN960-8	12-4	320
AN960-6L	3-16	90	AN960-8	3-1	170
AN960-6L	3-17	100	AN960-8	3-7	260
AN960-6L	3-17	120	AN960-8	3-7	290
AN960-6L	3-17	40	AN960-8	6-1	–
AN960-6L	6-14	30	AN960-8	6-11	170
AN960-6L	6-4	–	AN960-8	6-11	220
AN960-6L	6-4	–	AN960-8	6-13	–
AN960-6L	6-4	–	AN960-8	6-7	120
AN960-6L	6-4	–	AN960-8	6-7	200
AN960-6L	6-4	–	AN960-8	11-11	190
AN960-6L	6-4	–	AN960-8	7-1	160
AN960-6L	6-6	220	AN960-8	7-8	120
AN960-6L	9-2	40	AN960-8	12-9	220
AN960-6L	9-3	100	AN960-816	4-3	140
AN960-6L	9-4	200	AN960-816	5-4	160

ENSTROM F-28/280 SERIES ILLUSTRATED PARTS CATALOG

PART NUMBER INDEX SECTIONS 3 THROUGH 7 AND 9 THROUGH 12 FIGURES 8-1 THROUGH 8-11

Part Number	Figure	Item	Part Number	Figure	Item
AN960-816L	3-24	200	AN960-8L	6-5	–
AN960-8L	10-2	–	AN960-8L	6-5	31
AN960-8L	10-2	–	AN960-8L	6-6	330
AN960-8L	10-3	–	AN960-8L	6-7	100
AN960-8L	10-3	–	AN960-8L	9-1	7
AN960-8L	10-3	–	AN960-8L	9-2	13
AN960-8L	10-3	–	AN960-8L	9-3	280
AN960-8L	10-3	–	AN960-8L	9-3	350
AN960-8L	10-4	200	AN960-8L	9-3	400
AN960-8L	10-4	260	AN960-8L	9-4	250
AN960-8L	10-4	400	AN960-8L	8-6	110
AN960-8L	10-4	80	AN960-8L	8-6A	50
AN960-8L	11-19	227	AN960-8L	11-13	120
AN960-8L	3-10	90	AN960-8L	11-14	120
AN960-8L	3-17	150	AN960-8L	11-16	130
AN960-8L	3-19	150	AN960-8L	11-17	160
AN960-8L	3-2	180	AN960-8L	7-1	70
AN960-8L	3-20	440	AN960-8L	7-1	–
AN960-8L	3-20	580	AN960-8L	7-1	–
AN960-8L	3-20A	440	AN960-8L	7-1	650
AN960-8L	3-20A	580	AN960-8L	7-1	–
AN960-8L	3-20B	440	AN960-8L	7-2	110
AN960-8L	3-20B	580	AN960-8L	7-4	190
AN960-8L	3-22	110	AN960-8L	7-5	190
AN960-8L	3-23	90	AN960-8L	7-5	340
AN960-8L	3-24	160	AN960-8L	7-8	40
AN960-8L	3-4	290	AN960-8L	7-9	310
AN960-8L	3-5	60	AN960-8L	7-11	460
AN960-8L	3-6	100	AN960-8L	7-15	330
AN960-8L	3-7	60	AN960-8L	7-16	80
AN960-8L	3-9	100	AN960-8L	7-17	130
AN960-8L	4-1	310	AN960-916	3-2	220
AN960-8L	5-1	360	AN960C10	3-29	110
AN960-8L	6-1	–	AN960-C10	5-6	–
AN960-8L	6-1	–	AN960C10L	11-11	80
AN960-8L	6-1	–	AN960-C10L	12-3	80
AN960-8L	6-4	–	AN960-C10L	7-1	–
AN960-8L	6-5	--	AN960C1216	4-2	260

ENSTROM F-28/280 SERIES ILLUSTRATED PARTS CATALOG

PART NUMBER INDEX SECTIONS 3 THROUGH 7 AND 9 THROUGH 12 FIGURES 8-1 THROUGH 8-11

Part Number	Figure	Item	Part Number	Figure	Item
AN960C1216	5-3	470	AX142P	11-20	90
AN960C1216	8-11	270	B-00264-3	6-2	50A
AN960-C1216	7-20	570	B-00375-4	6-14	–
AN960-C416	7-1	–	B-00378-5	11-8	400
AN960C416L	12-2	100	B-00378-5	11-9	310
AN960C416L	12-2	100A	B-00378-5	6-14	–
AN960C516	3-29	140	B-00378-5	11-7	870
AN960-C516	7-1	140	B-1210	12-13	50
AN960-C516L	6-13	196	B44-28-2	11-18	130
AN960C616L	3-8	170	B-44-28-2	12-4	150
AN960C816	5-3	120	B46-2 1/2	8-9	230
AN960D10L	3-26	210	B46-2 1/2	8-10	230
AN960D10L	8-2	20	B-4855B-330	11-3	340
AN960D10L	7-16	50	B-4855B-330	11-4	330
AN960D516	4-1	30	B-4855B-330	11-5	–
AN960D516	8-4	220	B-4855B-330	11-6	40
AN960D616	4-2	310	B-710	11-18	125
AN960D8	4-1	160	B-710	12-4	160
AN960D8	4-2	230	BA-15	3-1	–
AN960D8	4-2	40	BA-15	3-2	–
AN960PD10	7-9	340	BLDS4-13W/LT	7-20	540
AN960PD10L	7-17	100	BPF-1/2	7-17	190
AN960PD416	11-20	140	C-2400L4VT-AB	11-1	–
AN960PD416	7-17	210	C2400L4VWAB-RG	11-5	260A
AN960PD6L	11-20	60	C-2400L4VW-AB-RG	11-2	–
AN960PD6L	7-11	430	C-2400L4VW-AB-RG	11-3	–
AN962-C516L	6-13	196	C-2400L4VW-AB-RG	11-4	270
AN970-3	6-13	95	C352TS	9-2	33A
AN975-3	12-2	70	C352TS	9-3	380
ANL80	6-13	190	C6052-8Z-1	3-27	–
AP18AU06-02	3-6	10	C6191-8Z-1	6-12	40
AP22-6	4-3	110	C-6352-10Z	3-28	–
AR134-D	7-1	320	C-836-06	6-12	120
AS3494-01	3-8	120	CA151PL	3-1	30
AS3578-152	5-4	50	CA-3251	7-1	350
ASMK8T	5-3	520	CAV-110H-U	3-23	620
AWG-22-8503-10	11-8	490	CAV-110R	3-23	310
AWG-22-8503-2	11-8	495	CAV-110R	3-23	620

ENSTROM F-28/280 SERIES ILLUSTRATED PARTS CATALOG

PART NUMBER INDEX SECTIONS 3 THROUGH 7 AND 9 THROUGH 12 FIGURES 8-1 THROUGH 8-11

Part Number	Figure	Item	Part Number	Figure	Item
CAV-110RV	3-23	620	CR91484-4-04	7-5	-60
CB35M	6-10	10	CR91484-4-05	7-5	-70
CB6009CR08-1P	7-6	250	CR91484-4-3	7-5	50
CBLS18C	6-11	300	CR91484-4-4	7-2	150
CBR1.5I-M	11-17	200	CR91484-4-4	7-5	-60
CBR1M-M	11-17	190	CR91484-4-5	7-5	-70
CBR2M-M	11-17	190	CS-N-346	6-12	110
CBR3I-M	11-17	200	D1250	7-21	190
CBR3S-M	11-16	150	D6-167	6-6	300
CBR3S-M	11-17	210	D6-167	11-20	30
CC-3251	7-4	10	D6810A-12	6-4	110
CC-3251	7-5	830	D6SE-167GY	11-20	30
CCA-1600	3-6	130	D-7080A-12	6-4	140
CCH25-S10	11-16	40	DG-167	11-16	50
CCH25-S10	11-17	70	EC-801-807	7-5	-
CCR264SS-3-03	5-3	-	ECD001-11	12-13	140
CCR264-SS3-3	6-8	-	ECD001-11	12-12	130
CCR264-SS3-3	6-8	-	ECD002-11	12-13	160
CCR274SS-3-02	10-4	310	ECD002-11	12-12	150
CCR274SS-3-02	11-21	180	ECD002-13	12-13	160
CCR274SS-3-04	7-20	410	ECD002-13	12-11	270
CD7	12-1	-110	ECD009-11	8-1	30
CD7L	5-6	138	ECD013-11	8-3A	100
CF600391-00	3-3	-	ECD013-13	8-3A	-
CGP-2	3-23	640	ECD014-11	5-4	260
CL30914-2	5-4	-	ECD014-13	5-4	260
CM1816	6-5	20	ECD015-11	12-3	20
CP25WB+	11-19	215	ECD016-11	12-7	90
CR 17240	4-2.1	20	ECD016-11	12-8	70
CR163-4-4	10-3	13	ECD016-11	12-5	-
CR163-4-4	10-4	310	ECD018-11	5-3	40
CR-163-4-6	7-1	790	ECD020-11	5-4	90
CR3212-4-4	7-4	220	ECD020-13	5-4	90
CR3213-4-2	6-13	110	ECD030-11	8-3A	390
CR3213-4-2	7-4	130	ECD030-11	12-5	-
CR3213-4-4	7-4	260	ECD030-11	12-5	630
CR3213-5-04	6-11	-	ECD034-11	8-9	280
CR91484-4-03	7-5	50	ECD034-11	8-10	280

ENSTROM F-28/280 SERIES ILLUSTRATED PARTS CATALOG

PART NUMBER INDEX SECTIONS 3 THROUGH 7 AND 9 THROUGH 12 FIGURES 8-1 THROUGH 8-11

Part Number	Figure	Item	Part Number	Figure	Item
ECD035-11	12-10	40	ECD071-103	11-8	123
ECD036-11	5-3	300	ECD071-103	11-9	47
ECD037-11	811	250	ECD071-103	11-6	240
ECD050-11	12-6	20	ECD071-103	11-7	250
ECD050-11	12-6	90	ECD071-104	11-8	124
ECD050-11	12-7	140	ECD071-104	11-9	48
ECD050-11	3-3	60	ECD071-104	11-6	250
ECD050-11	5-1	480	ECD071-104	11-7	260
ECD050-11	7-6	40	ECD071-105	11-8	125
ECD050-11	8-11	160	ECD071-105	11-9	49
ECD050-11	8-3	110	ECD071-105	11-6	260
ECD050-11	8-3A	320	ECD071-105	11-7	270
ECD050-11	8-5	350	ECD071-106	11-8	126
ECD050-11	9-5	25	ECD071-106	11-9	50
ECD050-11	12-13	290	ECD071-106	11-6	270
ECD050-11	8-8	120	ECD071-106	11-7	280
ECD050-11	7-1	250	ECD071-107	11-8	127
ECD050-11	12-5	380	ECD071-107	11-9	51
ECD050-11	12-10	170	ECD071-107	11-6	280
ECD050-11	12-11	220	ECD071-107	11-7	290
ECD050-11	12-12	260	ECD071-108	11-8	128
ECD050-15	8-11	270	ECD071-108	11-9	52
ECD050-17	12-13	290	ECD071-108	11-6	290
ECD050-19	8-4	150	ECD071-108	11-7	300
ECD050-23	11-19	125	ECD071-11	11-1	190
ECD050-25	8-11	20	ECD071-11	11-2	80
ECD060-11	7-6	-175	ECD071-11	11-3	-
ECD060-12	7-6	-185	ECD071-11	11-3	80
ECD060-5	7-5	680	ECD071-11	11-4	80
ECD066-1	11-18	115	ECD071-11	11-5	90
ECD066-1	12-4	180	ECD071-11	11-6	230
ECD066-1	8-9	170	ECD071-15	11-8	122
ECD066-1	8-10	170	ECD071-15	11-9	46
ECD069-11	6-1	90	ECD071-15	11-6	230
ECD069-11	6-2	10	ECD071-15	11-7	240
ECD069-11	6-2	10A	ECD071-3	11-1	200
ECD069-11	6-2	50A	ECD071-3	11-2	90
ECD069-13	6-2	10B	ECD071-3	11-3	-

ENSTROM F-28/280 SERIES ILLUSTRATED PARTS CATALOG

PART NUMBER INDEX SECTIONS 3 THROUGH 7 AND 9 THROUGH 12 FIGURES 8-1 THROUGH 8-11

Part Number	Figure	Item	Part Number	Figure	Item
ECD071-3	11-3	90	ECD072-11	11-7	390
ECD071-3	11-4	90	ECD073-1	6-11	90
ECD071-3	11-5	100	ECD073-3	6-11	90A
ECD071-4	11-1	220	ECD075-11	6-1	30
ECD071-4	11-2	110	ECD075-11	6-2	20
ECD071-4	11-3	–	ECD075-11	6-2	20A
ECD071-4	11-3	110	ECD075-11	6-2	20A
ECD071-4	11-4	110	ECD075-13	6-2	20A
ECD071-4	11-5	110	ECD075-13	6-2	20A
ECD071-5	11-1	240	ECD077-11	11-8	165
ECD071-5	11-2	130	ECD077-11	11-9	70
ECD071-5	11-3	–	ECD077-11	11-3	–
ECD071-5	11-3	130	ECD077-11	11-5	80
ECD071-5	11-4	130	ECD077-11	11-6	310
ECD071-5	11-5	120	ECD077-11	11-7	380
ECD071-6	11-1	210	ECD078-11	11-8	465
ECD071-6	11-2	100	ECD078-11	11-9	375
ECD071-6	11-3	–	ECD078-11	11-3	–
ECD071-6	11-3	100	ECD078-11	11-5	–
ECD071-6	11-4	100	ECD078-11	11-7	990
ECD071-6	11-5	130	ECD078-11	11-12	–140A
ECD071-7	11-1	230	ECD079-11	11-3	–
ECD071-7	11-2	120	ECD079-11	11-12	140
ECD071-7	11-3	–	ECD083-1	7-20	460
ECD071-7	11-3	120	ECD085-1	7-20	–
ECD071-7	11-4	120	ECD085-13	7-20	–
ECD071-7	11-5	140	ECD085-3	7-20	180
ECD071-8	11-1	250	ECD088-11	3-25	10
ECD071-8	11-2	140	ECD088-13	3-25	10
ECD071-8	11-3	–	ECD088-15	3-25	10
ECD071-8	11-3	140	ECD089-3	11-8	45
ECD071-8	11-4	140	ECD089-3	11-9	25
ECD071-8	11-5	150	ECD089-3	11-7	70
ECD072-11	11-8	170	ECD091-1	4-4	200
ECD072-11	11-9	80	ECD091-1	5-3	520
ECD072-11	11-3	–	ECD093-11	3-24	440
ECD072-11	11-5	70	ECD108-1	11-18	60
ECD072-11	11-6	350	ECD108-3	11-18	65

ENSTROM F-28/280 SERIES ILLUSTRATED PARTS CATALOG

PART NUMBER INDEX SECTIONS 3 THROUGH 7 AND 9 THROUGH 12 FIGURES 8-1 THROUGH 8-11

Part Number	Figure	Item	Part Number	Figure	Item
ECD108-3	12-4	20	F12NE4753-048	12-6	110
ECD110-11	3-8	190	F12NE-4753-048	12-7	150
ECD111-11	3-3	260	F12NE-4753-048	5-1	290
ECD112-1	11-9	100	F12NE-4753-048	5-3	400
ECD112-3	11-9	170	F12NE-4753-048	8-3	90
ECD4079-1	6-11	41	F12NE-4753-048	8-3A	360
ECD4089-11	9-4	140	F12NE-4753-048	8-4	270
ECD4089-15	9-4	150	F12NE-4753-048	8-5	410
EGT-701-4C-A-T	11-8	-	F12-NE-4753-048	3-11	310
EGT-701-4C-A-T	11-19	5	F12-NE-4753-048	12-10	200
EL-037360-107	3-28	10	F12NE-4753-054	8-6A	190
EL-037360-110	3-28	70	F12NE-4753-054	12-7	60
EL-037360-111	3-28	70	F12NE-4753-054	12-8	240
EL-037360-112	3-28	120	F12NE-4753-054	5-1	440
EL-037360-112	3-28	120	F12NE-4753-054	5-2	100
EL-037360-113	3-28	60	F12NE-4753-054	8-3	40
EL-037360-116	3-28	130	F12NE-4753-054	8-4	180
EL-037360-123	3-28	130	F12NE-4753-054	8-5	460
EL-037360-202	3-28	20	F12NE-4753-054	8-5A	120
EL-037360-206	3-28	80	F12NE-4753-064	8-5A	70
EL-037360-401	3-28	30	F12NE-4753-080	4-3	160
EL-037360-401	3-28	90	F6YN-625BK	11-20	20
EL-099005-401	3-27	50	F965	5-6	190
EL-099005-401	3-28	30	FB68-4	5-1	390
EL-099005-401	3-28	90	FIT-221V-3/32	11-8	-
ENS1001	3-3	270	FIT-221V-3/32	11-19	170
ENX-0001	3-28	130	FN22M-624	4-3	120
ENX-0001	3-3	-	FN22M-624	5-6	280
F12-NE-4527-02	3-14	50	G08DU	3-10	310
F12NE4717-048	8-2	60	G08DU	3-10	310
F12NE4717-070	8-1	120	G08DU	3-13	30
F12NE4753-02	3-28	350	G199-105-4	3-22	240
F12NE-4753-02	12-7	220	G199-105-4	3-23	250
F12-NE-4753-02	3-10	240	G2-0032	8-5	-180I
F12-NE-4753-02	3-11	410	G-243	6-13	80
F12-NE-4753-02	3-13	100	G-38517-B-7-A	8-5	180
F12-NE-4753-02	3-14	50	G-89	3-16	-
F12-NE-4753-02	3-15	50	G-89	3-16	-

ENSTROM F-28/280 SERIES ILLUSTRATED PARTS CATALOG

PART NUMBER INDEX SECTIONS 3 THROUGH 7 AND 9 THROUGH 12 FIGURES 8-1 THROUGH 8-11

Part Number	Figure	Item	Part Number	Figure	Item
G-89	3-16	–	HFVV3M	3-28	290
G-89	3-20	–	HFVV3M	3-28	290
G-89	3-20	–	HFVV3M	3-28	290
G-89	3-20	–	HFVV3M	3-28	290
G-89	3-20	–	HFVV-3M	3-10	260
G-89	3-20A	–	HHJ-A	11-17	40
G-89	3-20A	–	HLUH	8-9	190
G-89	3-20B	–	HMLVV5M	12-5	180
G-89	3-20B	–	HMLVV-5M	8-5	270
G-89	3-20B	–	HMVV-5	8-3	60
G-89	3-20B	–	HMVV5M	12-5	300
GA4-250	3-2	112	HMVV-5M	8-3	60
GA4-250	3-20	–	HMVV-5M	8-5	280
GA4-250	3-20A	–	HMVV-5M	8-6A	110
GA4-250	3-20A	–	HPF1260-6-58	4-3	90
GA4-250	3-20B	–	HR, DF-14R	6-6	90
GA4-250	3-20B	–	J-10386-2	3-30	–
GA4-250	3-20B	–	J-2214-4	3-30	60
GA4-250	3-20B	–	J-2216-18	3-30	10
GA4-250	7-1	540	J-2218-61	3-30	20
GA4-250	7-9	170	J-2309-7	3-30	50
GB-910	8-4	70	J3459-8	8-9	140
GE4313 (250W)	6-4	210	J3459-8	8-10	140
GEE62FR-C	11-19	–	J-7763-26	3-30	30
GEM 610	11-17	10	J-7766-2	3-30	40
GH2 1/2	9-2	33A	J-D4N-300M	6-14	90
GS-3	3-23	640	JE-1	5-1	320
GS-3	7-11	410	K3N	3-28	250
GX-5	8-9	210	K3N	3-28	250
GX-5	8-10	210	K3N	3-28	250
H-103	6-6	70	K3N	3-28	250
H1-400-14	11-5	260	K9000S-1A	3-22	300
H2532-13	7-5	670	K-9000S-1A	3-24	340
H2532-15	7-5	–	K94RA	12-1	110A
H2532-16	7-5	–	KLIK-1185	7-20	540
HDUH	8-10	190	KN500B1/8	11-8	160
HFVV3M	3-14	30	KN500B1/8	11-9	125
HFVV3M	3-15	30	KN500B1/8	11-5	30

ENSTROM F-28/280 SERIES ILLUSTRATED PARTS CATALOG

PART NUMBER INDEX SECTIONS 3 THROUGH 7 AND 9 THROUGH 12 FIGURES 8-1 THROUGH 8-11

Part Number	Figure	Item	Part Number	Figure	Item
KN500B1/8	11-7	360	M81934/1-08C012	8-3A	430
KN500B1/8	11-1	420	M81935/1-08K	5-3	520
KN500B1/8	11-2	320	M83248/1-008	12-1	120
KN500B1/8	11-3	320	M83248-2-010	3-26	30
KN500B1/8	11-4	–	M83536/10-015M	6-14	90
KN500B1/8	11-6	340	M83536/10-024M	6-14	90
KP-16B	12-9	190	MC1-106-140	11-16	20
KP4A	3-11	230	MC1-A106B	11-16	30
KP4A	3-11	340	MIL-DTL-5593	11-8	–
KRP8A-C	12-10	130	MM-113-3/8	11-19	140
KRP8A-H	12-9	70	MP-100-012-70	11-1	310
KRP8A-H	12-10	130	MP-160-012-100	11-6	–390A
KUP-14D55-24	6-14	10	MP-160-012-70	11-1	40
KUP-14D55-472	6-14	10	MP-160-012-70	11-2	200
L-141C	11-5	330	MP-160-012-70	11-3	200
L-18X	4-2	60	MP-160-012-70	11-4	200
LDF-6-228	8-5	570	MP-160-012-70	11-5	210
LE-026B-00MW	7-5	690	MP-160-012-70	11-6	390
LED-40-1J-HG2-SBMMMD	11-9	10	MR-18	12-10	–
LED-40-1J-HG2-SBMMF	11-9	5	MR-18	12-11	300
LHSSE-5	8-3A	250	MRB-2400	9-2	42
LW-12878-4S260	3-23	480	MS15001-1	4-1	260
LW-13464	3-3	240	MS16555-27	4-2.1	30
LW-13476	3-3	190	MS16555-618	12-12	50
LW-13646	3-3	–	MS16562-211	8-9	210
LW-13807	3-3	310	MS16562-211	8-10	210
LW-13807	3-5	90	MS16562-213	5-5	70
LW-14485	3-3	230	MS16562-213	8-9	240
LW-16567	3-28	141	MS16562-213	8-10	240
LW-18959-175-34	11-19	65	MS16562-215	4-3	70
LW-18959-175-34	11-17	–	MS16633-4012	7-6	300
LWB-22-6-58	4-3	90	MS16998-10L	6-11	–
M-111	11-19	105	MS16998-44	7-17	180
M-111T	11-19	150	MS17825-3	12-7	220
M12883/41-14	6-14	100	MS17825-3	3-10	240
M144E	5-6	50	MS17825-3	3-11	410
M21919-DG3	7-1	200	MS17825-3	3-13	100
M-5050T	11-19	40	MS17825-3	3-15	50

ENSTROM F-28/280 SERIES ILLUSTRATED PARTS CATALOG

PART NUMBER INDEX SECTIONS 3 THROUGH 7 AND 9 THROUGH 12 FIGURES 8-1 THROUGH 8-11

Part Number	Figure	Item	Part Number	Figure	Item
MS17825-3	12-5	250	MS20074-304	8-2	10
MS17825-4	12-6	110	MS201044N3	3-6	170
MS17825-4	12-7	150	MS20253-1	7-8	220
MS17825-4	3-11	310	MS20253-2	7-1	430
MS17825-4	5-1	290	MS20253-2	7-1	570
MS17825-4	5-3	400	MS20253-P2-7200	7-4	-
MS17825-4	8-3	90	MS20257-1	7-8	210
MS17825-4	8-3A	360	MS20257-4	7-1	560
MS17825-4	8-4	270	MS20257-P4	7-1	420
MS17825-4	8-5	410	MS20364-1032	8-5	260
MS17825-4	12-5	400	MS20364-1032	8-5A	160
MS17825-4	12-10	200	MS20364-1032	8-6	60
MS17825-5	12-7	60	MS20364-1032	8-7	70
MS17825-5	12-8	240	MS20364-428	8-8	60
MS17825-5	5-1	440	MS20365-425	7-22	90
MS17825-5	5-2	100	MS20365-832	7-1	80
MS17825-5	8-3	40	MS20365-832	7-1	-
MS17825-5	8-4	180	MS20365-832	7-1	-
MS17825-5	8-5	460	MS20365-832	7-1	670
MS17825-5	8-5A	120	MS20365-832	7-4	150
MS17825-5	8-6A	190	MS20392-2C11	3-28	300
MS17825-6	8-5A	70	MS20392-2C17	7-6	60
MS17826-4	8-2	60	MS20392-3C25	12-5	120
MS17826-5	12-5	230	MS20426A3-3	7-18	-
MS17984C305	7-6	-75	MS20426A3-3	7-18	-
MS18063-8	7-4	660	MS20426A3-3	7-18	-
MS18066-14	8-1	90	MS20426A3-3	7-18	-
MS18066-8	7-6	270	MS20426A3-3.5	3-20	-
MS20002-C6	7-13	110	MS20426A3-3.5	3-20A	-
MS20002-C6	12-11	80	MS20426A3-3.5	3-20B	-
MS20006H12	7-13	120	MS20426A3-4	3-19	-
MS20006H14	7-13	100	MS20426A3-4	3-20	-
MS20073-05-A12	8-4	260	MS20426A3-4	3-20	-
MS20073-05-A6	8-4	250	MS20426A3-4	3-20	-
MS20074-03-04	5-3	430	MS20426A3-4	3-20A	-
MS20074-05-05	3-29	70	MS20426A3-4	3-20A	-
MS20074-05-06	4-2	340	MS20426A3-4	3-20B	-
MS20074-05-12	4-2	350	MS20426A3-4	3-20B	-

ENSTROM F-28/280 SERIES ILLUSTRATED PARTS CATALOG

PART NUMBER INDEX SECTIONS 3 THROUGH 7 AND 9 THROUGH 12 FIGURES 8-1 THROUGH 8-11

Part Number	Figure	Item	Part Number	Figure	Item
MS20426A3-4	3-20B	–	MS20426AD3-4	3-20	–
MS20426A3-4	3-20B	–	MS20426AD3-4	3-20	–
MS20426A3-4	3-20B	–	MS20426AD3-4	3-20	–
MS20426A3-4	3-20B	–	MS20426AD3-4	3-20	–
MS20426A3-4	9-3	–	MS20426AD3-4	3-20	–
MS20426A3-4	9-3	–	MS20426AD3-4	3-20	–
MS20426A3-4	9-4	–	MS20426AD3-4	3-20	–
MS20426A3-4	9-4	–	MS20426AD3-4	3-20A	–
MS20426A3-4	7-10	400	MS20426AD3-4	3-20A	–
MS20426A3-4	7-18	–	MS20426AD3-4	3-20A	–
MS20426A3-4	7-18	–	MS20426AD3-4	3-20A	–
MS20426A3-4	7-18	–	MS20426AD3-4	3-20A	–
MS20426AD3-2	3-26	–	MS20426AD3-4	3-20A	–
MS20426AD3-3	3-17	80	MS20426AD3-4	3-20A	–
MS20426AD3-3	3-20	–	MS20426AD3-4	3-20A	–
MS20426AD3-3	3-20	–	MS20426AD3-4	3-20B	–
MS20426AD3-3	3-20	–	MS20426AD3-4	3-20B	–
MS20426AD3-3	3-20A	–	MS20426AD3-4	3-20B	–
MS20426AD3-3	3-20A	–	MS20426AD3-4	3-20B	–
MS20426AD3-3	3-20A	–	MS20426AD3-4	3-20B	–
MS20426AD3-3	3-20B	–	MS20426AD3-4	3-20B	–
MS20426AD3-3	3-20B	–	MS20426AD3-4	3-20B	–
MS20426AD3-3	3-20B	–	MS20426AD3-4	3-20B	–
MS20426AD3-3	3-26	–	MS20426AD3-4	3-20B	–
MS20426AD3-3	6-12	50	MS20426AD3-4	7-10	410
MS20426AD3-3.5	3-20	–	MS20426AD3-5	7-10	280
MS20426AD3-3.5	3-20A	–	MS20427M4-7	3-21	–
MS20426AD3-3.5	3-20B	–	MS20470A3-3	3-20	–
MS20426AD3-4	3-16	70	MS20470A3-3	3-20A	–
MS20426AD3-4	3-18	–	MS20470A3-3	3-20B	–
MS20426AD3-4	3-18	–	MS20470A3-4	3-19	–
MS20426AD3-4	3-18	–	MS20470A3-4	3-20	–
MS20426AD3-4	3-18	–	MS20470A3-4	3-20	–
MS20426AD3-4	3-19	–	MS20470A3-4	3-20A	–
MS20426AD3-4	3-19	40	MS20470AD3-3	3-20	–
MS20426AD3-4	3-20	–	MS20470AD3-3	3-20A	–
MS20426AD3-4	3-20	–	MS20470AD3-3	3-5A	20

ENSTROM F-28/280 SERIES ILLUSTRATED PARTS CATALOG

PART NUMBER INDEX SECTIONS 3 THROUGH 7 AND 9 THROUGH 12 FIGURES 8-1 THROUGH 8-11

Part Number	Figure	Item	Part Number	Figure	Item
MS20470AD3-4	3-18	-	MS20500-524	3-3	180
MS20470AD3-4	3-20	-	MS20615-3M10	3-26	130
MS20470AD3-4	3-20	-	MS20668-3	12-5	-
MS20470AD3-4	3-20A	-	MS20812-4D	3-24	350
MS20470AD3-4	3-20A	-	MS20819-4D	11-15	-
MS20470AD3-4	3-20B	-	MS20819-4D	11-15	-
MS20470AD3-4	3-20B	-	MS20819-4D	11-15	-
MS20470AD3-4	3-20B	-	MS20819-4D	11-15	-
MS20470AD3-4	3-20B	-	MS20819-4D	11-15	-
MS20470AD3-4	3-20B	-	MS20819-4D	11-15	-
MS20470AD3-4	4-2	-	MS20819-4D	11-15	-
MS20470AD3-4	6-7	140	MS20819-4D	11-15	-
MS20470AD3-4	7-9	40	MS20819-4D	3-24	-
MS20470AD4-11	12-5	-	MS20822-2	11-10	30
MS20470AD4-11	12-5	-	MS20822-4	3-23	200
MS20470AD4-19	12-5	-	MS20822-4D	3-4	220
MS20470AD4-3	7-10	300	MS20822-6-6	3-23	240
MS20470AD4-3.5	7-10	510	MS20822-6-6	3-8	100
MS20470AD4-4	3-20	-	MS20822-6D	3-26	180
MS20470AD4-4	3-20	-	MS20822-6D	5-6	90
MS20470AD4-4	3-20A	-	MS20823	3-22	420
MS20470AD4-4	3-20A	-	MS20823-4	3-23	420
MS20470AD4-4	3-20B	-	MS20823-4	3-4	190
MS20470AD4-4	3-20B	-	MS20823-4D	11-10	120
MS20470AD4-4	3-20B	-	MS20823-6	3-23	410
MS20470AD4-4	7-9	250	MS-20823-6D	3-6	20
MS20470AD4-4	7-14	250	MS20913-1	3-23	280
MS20470AD4-5	3-20	-	MS20913-1D	3-22	340
MS20470AD4-5	3-20A	-	MS20995C20	12-8	-280
MS20470AD4-5	3-20B	-	MS20995C25	11-19	165
MS20470AD4-6	7-15	220	MS20995-C25	12-5	680
MS20470AD4-6	7-16	140	MS20995C32	12-13	-
MS20470AD4-7	7-15	210	MS20995C32	12-1	-250
MS20470AD4-7	7-16	130	MS20995C32	3-23	-
MS20470AD5-7	3-21	-	MS20995C32	3-28	-
MS20500-1032	3-29	150	MS20995C32	3-3	-
MS20500-428	3-29	160	MS20995C32	3-3	-
MS20500-524	3-29	170	MS20995C32	3-3	-

ENSTROM F-28/280 SERIES ILLUSTRATED PARTS CATALOG

PART NUMBER INDEX SECTIONS 3 THROUGH 7 AND 9 THROUGH 12 FIGURES 8-1 THROUGH 8-11

Part Number	Figure	Item	Part Number	Figure	Item
MS20995C32	4-4	-	MS21044N3	3-10	190
MS20995C32	5-2	-	MS21044N3	3-10	40
MS20995C32	5-6	-	MS21044N3	3-11	100
MS20995C32	7-21	100	MS21044N3	3-12	50
MS20995C32	12-11	-	MS21044N3	3-20	520
MS20995C32	12-12	-	MS21044N3	3-20A	520
MS20995-C32	3-26	-	MS21044N3	3-20B	520
MS20995-C32	12-5	490	MS21044N3	3-23	580
MS20995C41	3-3	-	MS21044N3	3-6	270
MS20995-C41	12-5	480	MS21044N3	3-7	140
MS21042-3	3-27	70	MS21044N3	5-3	220
MS21042-3	3-28	110	MS21044N3	6-2	-
MS21042-3	3-28	110	MS21044N3	6-2	-
MS21042-3	3-28	50	MS21044N3	9-5	80
MS21042-3	7-6	130	MS21044N3	9-5	125
MS21042-3	7-6	470	MS21044N3	11-7	630
MS21044N04	11-8	120	MS21044N3	11-11	90
MS21044N04	11-9	-	MS21044N3	7-9	110
MS21044N04	11-7	230	MS21044N3	7-9	350
MS21044N06	3-17	130	MS21044N3	7-10	610
MS21044N06	6-11	120	MS21044N3	7-15	70
MS21044N06	7-8	150	MS21044N3	7-16	60
MS21044N06	7-9	70	MS21044N3	7-17	160
MS21044N06	7-10	460	MS21044N3	7-20	160
MS21044N06	7-21	280	MS21044N4	12-2	110
MS21044N08	3-10	100	MS21044N4	5-4	410
MS21044N08	6-11	221	MS21044N4	6-2	-
MS21044N08	6-2	-	MS21044N4	7-6	90
MS21044N08	8-6	120	MS21044N4	9-5	30
MS21044N08	8-6A	60	MS21044N4	7-5	890
MS21044N08	7-5	380	MS21044N4	7-15	190
MS21044N08	7-8	50	MS21044N4	7-16	220
MS21044N08	7-9	320	MS21044N4	7-17	250
MS21044N08	7-10	360	MS21044N4	7-19	100
MS21044N3	11-8	300	MS21044N4	7-20	120
MS21044N3	11-9	225	MS21044N5	4-1	140
MS21044N3	12-2	80	MS21044N5	7-19	70
MS21044N3	12-4	-300	MS21044N5	7-20	70

ENSTROM F-28/280 SERIES ILLUSTRATED PARTS CATALOG

PART NUMBER INDEX SECTIONS 3 THROUGH 7 AND 9 THROUGH 12 FIGURES 8-1 THROUGH 8-11

Part Number	Figure	Item	Part Number	Figure	Item
MS21044N6	5-4	380	MS21078-08K	3-19	30
MS21044N6	7-20	440	MS21078-08K	3-20	-
MS21045L3	3-3	-	MS21078-08K	3-20A	-
MS21045L5	3-3	180	MS21078-3	3-20	-
MS21059L3	3-26	-	MS21078-3	3-20	-
MS21061L08K	3-20	-	MS21078-3	3-20	-
MS21069-06	3-18	-	MS21078-3	3-20A	-
MS21069-06	3-20	-	MS21078-3	3-20A	-
MS21069-06	3-20	-	MS21078-3	3-20B	-
MS21069-06	3-20	-	MS21078-3	3-20B	-
MS21069-06	3-20A	-	MS21078-3	3-20B	-
MS21069-06	3-20A	-	MS21078-3	3-20B	-
MS21069-06	3-20A	-	MS21078-3	3-20B	-
MS21069-06	3-20B	-	MS21080-06	3-20	-
MS21069-06	3-20B	-	MS21080-06	3-20	-
MS21069-06	3-20B	-	MS21080-06	3-20A	-
MS21069-06K	3-20	-	MS21080-06	3-20A	-
MS21069-06K	3-20	-	MS21080-06	3-20B	-
MS21069-06K	3-20A	-	MS21080-06	3-20B	-
MS21069-06K	3-20A	-	MS21080-08	3-19	-
MS21069-06K	3-20B	-	MS21080-08K	3-19	-
MS21069-06K	3-20B	-	MS21080-08K	7-10	290
MS21069-08	3-20	-	MS21080-3	3-20	-
MS21069-08	3-20A	-	MS21080-3	3-20	-
MS21069-08	3-20B	-	MS21080-3	3-20A	-
MS21071-06	3-18	-	MS21080-3	3-20B	-
MS21071-06	3-18	-	MS21080-3	3-20B	-
MS21071-06	3-20	-	MS21080-3	3-20B	-
MS21071-06	3-20A	-	MS21083N06	11-8	40
MS21071-06	3-20B	-	MS21083N06	11-9	-
MS21078-06	3-20	-	MS21083N06	11-9	-
MS21078-06	3-20A	-	MS21083N06	11-9	-
MS21078-06	3-20B	-	MS21083N06	6-11	-
MS21078-08	3-19	-	MS21083N06	6-14	40
MS21078-08	3-19	-	MS21083N06	6-4	-
MS21078-08	3-20B	-	MS21083N06	6-4	-
MS21078-08	3-20B	-	MS21083N06	6-4	-
MS21078-08K	3-19	-	MS21083N06	6-4	-

ENSTROM F-28/280 SERIES ILLUSTRATED PARTS CATALOG

PART NUMBER INDEX SECTIONS 3 THROUGH 7 AND 9 THROUGH 12 FIGURES 8-1 THROUGH 8-11

Part Number	Figure	Item	Part Number	Figure	Item
MS21083N06	6-4	-	MS21083N3	6-13	188
MS21083N06	6-4	-	MS21083N3	6-13	195
MS21083N06	6-6	190	MS21083N3	6-2	-
MS21083N06	12-13	330	MS21083N3	6-2	-
MS21083N06	11-7	160	MS21083N3	6-3	40
MS21083N06	7-1	-	MS21083N3	7-6	460
MS21083N06	7-11	440	MS21083N3	8-11	70
MS21083N06	12-5	-	MS21083N3	8-6A	150
MS21083N06	12-11	50	MS21083N3	8-7	-
MS21083N06	12-12	300	MS21083N3	7-1	-
MS21083N08	11-8	315	MS21083N3	7-3	70
MS21083N08	11-9	240	MS21083N3	7-9	140
MS21083N08	11-19	245	MS21083N3	7-17	110
MS21083N08	6-11	160	MS21083N3	12-5	150
MS21083N08	6-11	80	MS21083N4	3-22	180
MS21083N08	6-5	230	MS21083N4	3-22	290
MS21083N08	6-5	32	MS21083N4	3-23	190
MS21083N08	6-6	340	MS21083N4	5-1	490
MS21083N08	6-7	110	MS21083N4	5-1	70
MS21083N08	6-7	210	MS21083N4	5-5	140
MS21083N08	11-7	670	MS21083N4	7-17	360
MS21083N08	11-11	200	MS21083N4	8-11	10
MS21083N08	7-5	200	MS21083N4	8-11	150
MS21083N08	7-11	470	MS21083N4	12-13	300
MS21083N12	7-20	560	MS21083N4	7-20	260
MS21083N3	3-11	160	MS21083N4	7-21	30
MS21083N3	3-13	60	MS21083N4	12-5	420
MS21083N3	3-21	50	MS21083N4	12-10	160
MS21083N3	3-26	220	MS21083N4	12-11	230
MS21083N3	3-5A	130	MS21083N4	12-12	270
MS21083N3	3-5A	210	MS21083N5	5-4	230
MS21083N3	4-2	-	MS21083N5	7-20	-
MS21083N3	5-1	150	MS21083N6	4-2	320
MS21083N3	5-3	460	MS21083N6	5-3	330
MS21083N3	5-5	300	MS21083N6	7-19	40
MS21083N3	6-13	-	MS21240-08C12	8-3A	430
MS21083N3	6-13	-	MS21242S8	5-3	520
MS21083N3	6-13	-	MS21242S8K	4-4	200

ENSTROM F-28/280 SERIES ILLUSTRATED PARTS CATALOG

PART NUMBER INDEX SECTIONS 3 THROUGH 7 AND 9 THROUGH 12 FIGURES 8-1 THROUGH 8-11

Part Number	Figure	Item	Part Number	Figure	Item
MS21242S8K	5-3	520	MS21919WCJ10	3-23	481
MS21250-06042	5-6	250	MS21919WCJ10	3-4	30
MS21250-06044	5-6	250	MS21919WCJ10	11-17	120
MS21251-B3S	12-5	800	MS21919WCJ12	3-20	560
MS21255-3LS	12-5	810	MS21919WCJ12	3-20A	560
MS21255-3RS	12-5	830	MS21919WCJ12	3-20B	560
MS21256-1	12-5	820	MS21919WCJ12	3-20B	560
MS21262-6	12-9	100	MS21919WCJ12	3-23	70
MS21262-6	12-10	100	MS21919WCJ12	3-24	220
MS21299C6	4-3	100	MS21919WCJ12	3-4	270
MS21913J4	11-19	145	MS21919WCJ12	6-2	60
MS21919CJ15	11-14	-	MS21919WCJ12	11-17	130
MS21919DF12	11-17	130	MS21919WCJ14	3-24	310
MS21919DF-12	11-16	100	MS21919WCJ16	3-23	380
MS21919-DF12	3-1	50	MS21919WCJ16	11-17	140
MS21919-DF12	3-2	80	MS21919WCJ3	3-24	115
MS21919-DF12	3-6	80	MS21919WCJ3	11-17	90
MS21919DF16	11-17	140	MS21919WCJ4	3-24	170
MS21919DF-3	11-16	110	MS21919WCJ4	3-4	240
MS21919-DF6	3-6	80	MS21919WCJ4	11-17	100
MS21919-DG12	6-13	20	MS21919WCJ6	3-24	300
MS21919-DG-15	11-14	-	MS21919WCJ6	3-4	250
MS21919DG3	11-17	90	MS21919WCJ6	11-17	110
MS21919-DG3	7-5	330	MS21919WCJ8	3-4	260
MS21919DG4	3-24	170	MS21919WDF12	3-5	40
MS21919F10	11-17	120	MS21919WDF3	3-22	460
MS21919-F10	3-4	30	MS21919WDG12	3-24	-
MS21919-F12	3-4	270	MS21919WDG12	3-24	220
MS21919F4	11-11	60	MS21919WDG12	3-5A	180
MS21919F4	11-17	100	MS21919WDG12	6-13	20
MS21919-F4	3-4	240	MS21919WDG-12	11-18	35
MS21919F6	11-17	110	MS21919WDG-12	12-4	80
MS21919-F6	3-4	250	MS21919WDG14	3-24	310
MS21919F8	10-4	60	MS21919WDG14	3-5A	100
MS21919-F8	10-3	-	MS21919WDG-14	11-18	30
MS21919-F8	3-4	260	MS21919WDG-14	12-4	70
MS21919-G38	10-2	-	MS21919WDG15	11-15	125
MS21919WCJ10	3-23	390	MS21919WDG2	6-5	215

ENSTROM F-28/280 SERIES ILLUSTRATED PARTS CATALOG

PART NUMBER INDEX SECTIONS 3 THROUGH 7 AND 9 THROUGH 12 FIGURES 8-1 THROUGH 8-11

Part Number	Figure	Item	Part Number	Figure	Item
MS21919WDG3	10-4	140	MS24665-1013	8-3A	370
MS21919WDG3	10-4	240	MS24665-1013	8-4	300
MS21919WDG3	3-24	-	MS24665-1013	7-5	280
MS21919WDG3	6-7	80	MS24665-151	12-6	210
MS21919WDG-5	11-18	25	MS24665-151	12-7	250
MS21919WDG-5	12-4	60	MS24665-151	12-8	250
MS21919WDG6	11-19	250	MS24665-151	3-10	250
MS21919WDG6	3-24	300	MS24665-151	3-11	320
MS21919WF10	3-22	390	MS24665-151	3-13	110
MS21919WF12	3-20	560	MS24665-151	3-14	60
MS21919WF12	3-20A	560	MS24665-151	3-15	60
MS21919WF12	3-20B	560	MS24665-151	5-1	300
MS21919WF12	3-22	80	MS24665-151	5-2	110
MS21919WF12	3-7	90	MS24665-151	5-3	410
MS21919WF12	6-1	120	MS24665-151	5-5	170
MS21919WF12	6-1	60	MS24665-151	8-3	100
MS21919WF14	3-22	90	MS24665-151	8-4	190
MS21919WF14	3-7	90	MS24665-151	8-5	420
MS21919WF16	3-22	380	MS24665-151	8-5A	130
MS21919WF16	5-5	280	MS24665-151	8-6A	200
MS21919WF18	3-7	40	MS24665-151	12-5	260
MS21919WF4	11-15	130	MS24665-151	12-10	210
MS21919WF4	3-20	620	MS24665-152	8-3	50
MS21919WF4	3-20A	620	MS24665-152	8-5	470
MS21919WF4	3-20B	620	MS24665-153	3-24	530
MS21919WF-4	3-24	170	MS24665-153	3-28	305
MS21919WF6	3-22	70	MS24665-153	12-5	240
MS21919WG38	10-4	250	MS24665-155	12-8	90
MS21919WG38	10-4	420	MS24665-155	12-5	-
MS21919WG38	10-4	70	MS24665-157	12-5	870
MS24566-1B	12-5	890	MS24665-300	3-28	320
MS24566-2B	12-5	860	MS24665-300	3-30	60
MS24566-3B	12-5	880	MS24665-300	3-30	60A
MS24586C234	3-11	480	MS24665-300	8-1	130
MS24586C311	3-11	470	MS24665-300	8-5A	80
MS24586-C346	3-11	200	MS24665-300	12-5	840
MS24665-1013	12-6	100	MS24665-302	4-3	170
MS24665-1013	8-2	70	MS24665-302	8-1	140

ENSTROM F-28/280 SERIES ILLUSTRATED PARTS CATALOG

PART NUMBER INDEX SECTIONS 3 THROUGH 7 AND 9 THROUGH 12 FIGURES 8-1 THROUGH 8-11

Part Number	Figure	Item	Part Number	Figure	Item
MS24665-302	8-3A	410	MS26574-20	11-5	240
MS24665-304	5-3	100	MS26574-5	6-3	-
MS24665-304	12-5	80	MS26574-7 1/2	11-5	220
MS24665-360	4-2	200	MS27039-0806	8-6	100
MS24665-377	12-5	340	MS27039-0806	8-6A	40
MS24665-90	3-28	375	MS27039-0806	7-1	440
MS24674-45	3-8	180	MS27039-0806	7-8	110
MS24677-52	4-2	350	MS27039-0807	6-5	100
MS24693-BB26	11-9	105	MS27039-0807	7-1	410
MS24693-BB26	11-9	175	MS27039-0807	7-5	600
MS24693-BB26	11-6	430	MS27039-0807	7-11	450
MS24693-BB50	11-8	370	MS27039-0808	6-5	110
MS24693-BB50	11-7	810	MS27039-0808	11-11	180
MS24693-C274	7-1	820	MS27039-0808	7-5	310
MS24693-S25	7-10	440	MS27039-0808	7-5	820
MS24693-S25	7-11	420	MS27039-0808	7-15	120
MS24693S26	9-3	80	MS27039-0808	7-16	260
MS24693S26	9-4	190	MS27039-0810	7-5	450
MS24693-S287	4-2	-	MS27039-1-09	7-6	110
MS24693-S48	7-6	240	MS27039-808	11-16	60
MS24693-S49	7-2	100	MS27404-4D	11-8	-
MS24693-S51	11-20	120	MS27769D3	3-26	170
MS24693-S51	7-1	680	MS28775-015	3-5	-
MS24693-S51	7-10	230	MS28775-018	12-1	40
MS24694-50	11-8	-	MS28775-026	3-9	60
MS24694-52	3-12	60	MS28775-029	4-2	140
MS24694-80	3-12	80	MS28775-111	12-6	40
MS24694-S13	7-4	280	MS28775-111	12-5	740
MS24694-S15	7-1	60	MS28775-113	12-1	80
MS24694-S52	7-6	140	MS28775-116	6-11	290
MS24694-S52	9-5	115	MS28775-214	3-9	70
MS24694-S58	6-13	192	MS28775-218	3-9	40
MS24694-S7	7-4	140	MS28775-218	7-21	160
MS25171-1S	6-13	240	MS28778-12	3-23	130
MS25171-3S	6-13	230	MS28778-2	12-1	60
MS25244-5	11-6	410	MS28778-2	3-26	80
MS25331-8	11-5	310	MS28778-3	12-1	20
MS26574-2 1/2	11-5	230	MS28778-3	5-6	-

ENSTROM F-28/280 SERIES ILLUSTRATED PARTS CATALOG

PART NUMBER INDEX SECTIONS 3 THROUGH 7 AND 9 THROUGH 12 FIGURES 8-1 THROUGH 8-11

Part Number	Figure	Item	Part Number	Figure	Item
MS28778-4	5-6	–	MS35206-244	3-6	230
MS28778-6	3-22	–	MS35206-244	3-7	250
MS28778-6	3-22	–	MS35206-244	3-7	280
MS28778-6	3-23	360	MS35206-244	3-9	90
MS28778-8	3-7	101	MS35206-244	6-11	61
MS28778-8	3-7	11	MS35206-244	6-2	–
MS28778-8	3-7	321	MS35206-244	6-2	–
MS28884A-6	3-4	140	MS35206-244	11-7	860
MS28889-2	7-21	90	MS35206-244	7-10	340
MS29512-06	3-22	–	MS35206-245	10-4	430
MS29512-06	3-22	–	MS35206-245	11-15	105
MS29512-06	3-22	–	MS35206-245	11-19	235
MS29513-010	3-26	60	MS35206-245	11-19	80
MS29513-113	3-26	40	MS35206-245	12-4	90
MS30526-230	3-24	130	MS35206-245	3-19	140
MS33737-16C	11-8	70	MS35206-245	3-20	570
MS33737-16C	11-7	110	MS35206-245	3-20A	570
MS35190-253	11-8	305	MS35206-245	3-20B	570
MS35190-253	11-9	230	MS35206-245	3-23	482
MS35190-253	11-7	650	MS35206-245	3-24	–
MS35206-219	8-9	60	MS35206-245	3-24	–
MS35206-219	8-10	60	MS35206-245	3-24	–
MS35206-227	7-1	–	MS35206-245	3-24	130
MS35206-228	6-11	100	MS35206-245	11-17	150
MS35206-228	6-4	300	MS35206-245	7-9	300
MS35206-228	11-20	40	MS35206-245	7-9	400
MS35206-228	7-9	50	MS35206-245	7-10	640
MS35206-229	11-20	50	MS35206-246	11-15	115
MS35206-230	3-26	110	MS35206-246	3-22	400
MS35206-230	6-11	–	MS35206-246	3-23	80
MS35206-230	7-1	–	MS35206-246	3-24	240
MS35206-244	11-8	395	MS35206-246	3-5	50
MS35206-244	11-9	305	MS35206-246	3-6	90
MS35206-244	3-17	140	MS35206-246	3-7	50
MS35206-244	3-19	–	MS35206-246	6-1	130
MS35206-244	3-20	430	MS35206-246	6-1	70
MS35206-244	3-20A	430	MS35206-246	6-2	–
MS35206-244	3-20B	430	MS35206-246	6-2	–

ENSTROM F-28/280 SERIES ILLUSTRATED PARTS CATALOG

PART NUMBER INDEX SECTIONS 3 THROUGH 7 AND 9 THROUGH 12 FIGURES 8-1 THROUGH 8-11

Part Number	Figure	Item	Part Number	Figure	Item
MS35206-246	6-2	–	MS35214-26	11-9	–
MS35206-246	11-16	120	MS35214-26	11-9	–
MS35206-246	7-10	580	MS35214-26	11-9	53
MS35206-247	11-8	410	MS35214-27	11-8	129
MS35206-247	11-9	320	MS35214-27	11-9	–
MS35206-247	11-15	140	MS35214-28	11-7	480
MS35206-247	6-2	–	MS35214-28	11-8	225
MS35206-247	11-7	770	MS35214-29	11-6	50
MS35206-249	11-15	135	MS35214-30	11-5	–
MS35206-249	11-14	110	MS35214-30	11-6	140
MS35206-249	12-9	210	MS35214-30	11-7	200
MS35206-250	11-8	430	MS35214-30	11-8	95
MS35206-250	11-9	340	MS35214-30	11-9	–
MS35206-250	11-7	900	MS35214-31	11-6	60
MS35206-251	11-15	100	MS35214-31	11-7	100
MS35206-251	11-14	–	MS35214-31	11-8	65
MS35207-10-16	12-10	280	MS35214-31	11-9	–
MS35207-262	3-5A	110	MS35214-31	11-9	–
MS35207-262	3-5A	190	MS35214-31	11-9	–
MS35207-262	6-2	–	MS35214-31	11-9	–
MS35207-262	6-2	–	MS35214-44	11-8	515
MS35207-262	12-13	250	MS35333-37	6-6	270
MS35207-263	6-2	–	MS35333-39	3-20	410
MS35207-263	6-2	–	MS35333-39	3-20A	410
MS35207-277	7-4	480	MS35333-39	3-20B	410
MS35207-AR	12-13	250	MS35333-40	7-10	210
MS35214-109	11-6	130	MS35333-47	3-15	90
MS35214-15	11-7	210	MS35333-47	3-24	450
MS35214-15	11-8	–	MS35338-40	8-9	80
MS35214-15	11-8	110	MS35338-40	8-10	80
MS35214-15	11-9	–	MS35338-41	11-19	55
MS35214-15	11-9	–	MS35338-41	3-16	100
MS35214-25	11-6	220	MS35338-41	3-20	360
MS35214-25	11-7	90	MS35338-41	3-20A	360
MS35214-25	11-8	55	MS35338-41	3-20B	360
MS35214-26	11-6	380	MS35338-41	11-5	–
MS35214-26	11-7	140	MS35338-41	11-6	90
MS35214-26	11-8	30	MS35338-41	11-20	70

ENSTROM F-28/280 SERIES ILLUSTRATED PARTS CATALOG

PART NUMBER INDEX SECTIONS 3 THROUGH 7 AND 9 THROUGH 12 FIGURES 8-1 THROUGH 8-11

Part Number	Figure	Item	Part Number	Figure	Item
MS35338-41	7-1	-	MS35338-43	6-2	-
MS35338-42	10-4	450	MS35338-43	6-2	-
MS35338-42	11-8	415	MS35338-43	9-5	50
MS35338-42	11-9	325	MS35338-43	8-9	-
MS35338-42	11-15	85	MS35338-43	8-10	-
MS35338-42	11-19	90	MS35338-44	5-6	230
MS35338-42	3-20	590	MS35338-44	6-2	-
MS35338-42	3-20A	590	MS35338-44	6-2	-
MS35338-42	3-20B	590	MS35338-44	6-2	-
MS35338-42	3-22	120	MS35338-99	11-8	510
MS35338-42	3-23	100	MS353630-42	3-7	70
MS35338-42	3-24	-	MS35489-1	6-4	-
MS35338-42	3-24	-	MS35489-10	3-24	-
MS35338-42	3-24	-	MS35489-11	3-15	140
MS35338-42	3-24	150	MS35489-11	11-17	60
MS35338-42	3-4	280	MS35489-11	11-19	220
MS35338-42	3-4	300	MS35489-14	11-19	180
MS35338-42	3-5	70	MS35489-14	3-24	-
MS35338-42	3-6	110	MS35489-4	6-11	-
MS35338-42	3-9	110	MS35489-5	6-4	290
MS35338-42	5-1	350	MS35489-6	6-10	70
MS35338-42	6-1	-	MS35489-6	6-7	220
MS35338-42	6-1	-	MS35489-6	6-7	70
MS35338-42	6-1	-	MS35489-6	11-16	90
MS35338-42	6-1	-	MS35489-6	11-17	80
MS35338-42	6-13	-	MS35649-202	6-2	-
MS35338-42	6-2	-	MS35649-2312	3-3	290
MS35338-42	6-2	-	MS35649-242	8-9	90
MS35338-42	6-2	-	MS35649-242	8-10	90
MS35338-42	11-7	780	MS35649-262	11-19	60
MS35338-42	11-7	910	MS35649-262	3-20	370
MS35338-42	11-14	130	MS35649-262	3-20A	370
MS35338-42	11-16	70	MS35649-262	3-20B	370
MS35338-42	11-17	170	MS35649-262	3-26	120
MS35338-42	7-1	660	MS35649-262	11-5	-
MS35338-42	7-2	120	MS35649-262	11-6	80
MS35338-43	3-1	80	MS35649-282	10-4	460
MS35338-43	3-25	60	MS35649-282	11-8	420

ENSTROM F-28/280 SERIES ILLUSTRATED PARTS CATALOG

PART NUMBER INDEX SECTIONS 3 THROUGH 7 AND 9 THROUGH 12 FIGURES 8-1 THROUGH 8-11

Part Number	Figure	Item	Part Number	Figure	Item
MS35649-282	11-9	330	MS35769-6	5-6	140
MS35649-282	11-15	90	MS35769-6	6-11	20
MS35649-282	11-19	95	MS35769-9	12-1	100
MS35649-282	12-4	120	MS35769-9	5-6	120
MS35649-282	3-20	600	MS35842-13	3-3	260
MS35649-282	3-20A	600	MS51500-B6-8	3-8	140
MS35649-282	3-20B	600	MS51525-B6-8	3-22	210
MS35649-282	3-22	130	MS51525B6-8Z	3-23	120
MS35649-282	3-23	110	MS51529B6S	3-22	360
MS35649-282	3-24	-	MS51529B6S	3-23	350
MS35649-282	3-24	-	MS51861-24	3-17	30
MS35649-282	3-24	-	MS51861-24	3-17	60
MS35649-282	3-24	140	MS51861-24	7-5	860
MS35649-282	3-4	310	MS51861-25	7-1	-
MS35649-282	3-5	80	MS51861-25	7-5	640
MS35649-282	3-6	120	MS51861-35	3-27	-
MS35649-282	3-7	80	MS51861-35	3-28	-
MS35649-282	3-9	120	MS51861-35	6-1	110
MS35649-282	5-1	370	MS51861-35	6-1	50
MS35649-282	6-1	-	MS51861-35	7-9	210
MS35649-282	6-1	-	MS51861-36	3-20	291
MS35649-282	6-1	-	MS51862-13	7-1	130
MS35649-282	6-1	-	MS51862-13	7-4	400
MS35649-282	6-13	-	MS51862-13	7-5	590
MS35649-282	6-2	-	MS51862-14	7-4	600
MS35649-282	6-2	-	MS75028-22	11-17	30
MS35649-282	6-2	-	MS9021-152	5-4	50
MS35649-282	8-3A	290	MS9352-03	3-22	460
MS35649-282	11-7	790	MTK8	5-3	520
MS35649-282	11-14	140	MW-3TM-29	3-14	30
MS35649-282	11-16	80	N-09	4-3	10
MS35649-282	11-17	180	N5000-112-PP	12-9	80
MS35649-282	7-1	700	N5000-137-S-PP	5-3	30
MS35649-282	7-2	130	N5000-175-PP	12-1	170
MS35650-302	9-5	55	N5000-187-ZD	12-3	30
MS35650-302	8-9	-	N5000-206-PP	12-1	210
MS35650-302	8-10	-	N5000-268-PP	12-7	100
MS35769-11	5-6	125	N5000-62-PP	11-18	110

ENSTROM F-28/280 SERIES ILLUSTRATED PARTS CATALOG

PART NUMBER INDEX SECTIONS 3 THROUGH 7 AND 9 THROUGH 12 FIGURES 8-1 THROUGH 8-11

Part Number	Figure	Item	Part Number	Figure	Item
N5000-62-PP	12-4	190	NAS1097AD3-3	3-20	-
N5000-62-PP	8-9	150	NAS1097AD3-3	3-20A	-
N5000-62-PP	8-10	150	NAS1097AD3-3	3-20A	-
N5000-87	8-9	290	NAS1097AD3-3	3-20B	-
N5000-87	8-10	290	NAS1097AD3-3	3-20B	-
N5000-87-PP	8-9	290	NAS1097AD3-3	6-12	50
N5000-87-PP	8-10	290	NAS1097AD3-4	3-20	-
N5002-100	12-13	100	NAS1097AD3-4	3-20	-
N5002-100	12-12	80	NAS1097AD3-4	3-20	-
N5002-125-PP	8-1	40	NAS1097AD3-4	3-20	-
N5002-268-PP	12-8	80	NAS1097AD3-4	3-20	-
N5002-354-S-PP	5-4	310	NAS1097AD3-4	3-20	-
N5108-56-PP	8-9	370	NAS1097AD3-4	3-20	-
N5108-56-PP	8-10	370	NAS1097AD3-4	3-20A	-
NAJ-02BC	3-20A	-	NAS1097AD3-4	3-20A	-
NAJ1-02	3-26	-	NAS1097AD3-4	3-20A	-
NAJ1-02BC	3-20A	-	NAS1097AD3-4	3-20A	-
NAJ1-02BC	3-20A	-	NAS1097AD3-4	3-20A	-
NAJ17-02BC	3-20A	-	NAS1097AD3-4	3-20A	-
NAJ17-02BC	3-20B	-	NAS1097AD3-4	3-20B	-
NAJ17-82BC	3-19	-	NAS1097AD3-4	3-20B	-
NAJ17-82BC	3-20	-	NAS1097AD3-4	3-20B	-
NAJ17-82BC	3-20A	-	NAS1097AD3-4	3-20B	-
NAJ1-82BC	3-18	-	NAS1097AD3-4	3-20B	-
NAJ1-82BC	3-18	-	NAS1097AD3-4	3-20B	-
NAJ1-82BC	3-19	30	NAS1101-08-6	8-7	-
NAJ1-82BC	3-20A	-	NAS1101-08-6	8-10	380
NAJ1-82BC	3-20B	-	NAS1101-08-8	8-9	130
NAJ5-048	5-3	-	NAS1101-08-8	8-9	380
NAS1023D08K	3-18	-	NAS1101-08-8	8-10	130
NAS1023D08K	3-18	-	NAS1101-3-10	8-3A	260
NAS1023D08K	3-20A	-	NAS1101-3-10	8-9	20
NAS1023D08K	3-20B	-	NAS1101-3-10	8-10	20
NAS1068A08	3-20	-	NAS1101-3-10	7-15	140
NAS1068A08	3-20A	-	NAS1101-3-10	7-16	240
NAS1068A08	3-20B	-	NAS1101-3-8	8-9	-
NAS1097AD3-3	3-18	-	NAS1101-3-8	8-10	-
NAS1097AD3-3	3-20	-	NAS1149C0332R	12-3	80

ENSTROM F-28/280 SERIES ILLUSTRATED PARTS CATALOG

PART NUMBER INDEX SECTIONS 3 THROUGH 7 AND 9 THROUGH 12 FIGURES 8-1 THROUGH 8-11

Part Number	Figure	Item	Part Number	Figure	Item
NAS1149C0332R	11-11	80	NAS1149F0332P	3-10	150
NAS1149C0332R	7-1	-	NAS1149F0332P	3-10	180
NAS1149C0363R	3-29	110	NAS1149F0332P	3-12	40
NAS1149C0432R	12-6	80	NAS1149F0332P	3-13	50
NAS1149C0463R	12-6	60	NAS1149F0332P	3-14	20
NAS1149C0463R	12-6	70	NAS1149F0332P	3-15	20
NAS1149C0463R	5-3	160	NAS1149F0332P	3-20	575
NAS1149C0463R	12-5	750	NAS1149F0332P	3-20A	575
NAS1149C0563R	3-29	140	NAS1149F0332P	3-20B	575
NAS1149C0563R	7-1	140	NAS1149F0332P	3-20B	575
NAS1149C0632R	3-8	170	NAS1149F0332P	3-24	540
NAS1149C1290R	4-2	260	NAS1149F0332P	3-25	70
NAS1149C1290R	5-3	470	NAS1149F0332P	3-5A	120
NAS1149C1290R	7-20	570	NAS1149F0332P	3-5A	200
NAS1149D0316H	3-26	210	NAS1149F0332P	3-6	260
NAS1149D0316H	7-6	120	NAS1149F0332P	3-7	160
NAS1149D0316H	7-16	50	NAS1149F0332P	3-7	260
NAS1149D0316J	9-5	45	NAS1149F0332P	3-9	150
NAS1149D0316J	9-5	65	NAS1149F0332P	5-1	130
NAS1149D0316J	7-17	100	NAS1149F0332P	5-2	60
NAS1149D0363J	7-9	340	NAS1149F0332P	5-3	200
NAS1149D0463J	11-20	140	NAS1149F0332P	5-3	440
NAS1149D0463J	7-17	210	NAS1149F0332P	5-5	260
NAS1149D0563H	4-1	30	NAS1149F0332P	6-13	-
NAS1149D0563H	8-4	220	NAS1149F0332P	6-13	-
NAS1149D0663H	4-2	310	NAS1149F0332P	6-13	187
NAS1149DN832H	4-1	160	NAS1149F0332P	6-13	194
NAS1149DN832H	4-2	230	NAS1149F0332P	6-13	40
NAS1149DN832H	4-2	40	NAS1149F0332P	6-13	60
NAS1149DN832H	6-11	220	NAS1149F0332P	6-2	-
NAS1149F0316P	6-2	-	NAS1149F0332P	6-2	-
NAS1149F0316P	8-11	60	NAS1149F0332P	6-2	-
NAS1149F0316P	12-13	240	NAS1149F0332P	6-2	-
NAS1149F0332P	11-9	215	NAS1149F0332P	6-3	30
NAS1149F0332P	12-1	230	NAS1149F0332P	8-11	55
NAS1149F0332P	12-7	200	NAS1149F0332P	8-3A	270
NAS1149F0332P	12-8	270	NAS1149F0332P	8-5	250
NAS1149F0332P	3-1	60	NAS1149F0332P	8-5A	150

ENSTROM F-28/280 SERIES ILLUSTRATED PARTS CATALOG

PART NUMBER INDEX SECTIONS 3 THROUGH 7 AND 9 THROUGH 12 FIGURES 8-1 THROUGH 8-11

Part Number	Figure	Item	Part Number	Figure	Item
NAS1149F0332P	8-6	50	NAS1149F0363P	11-7	640
NAS1149F0332P	8-6A	140	NAS1149F0363P	7-3	100
NAS1149F0332P	8-7	60	NAS1149F0363P	7-4	160
NAS1149F0332P	9-5	15	NAS1149F0363P	7-5	580
NAS1149F0332P	11-7	620	NAS1149F0363P	7-9	130
NAS1149F0332P	12-13	–	NAS1149F0363P	7-10	660
NAS1149F0332P	7-3	60	NAS1149F0363P	7-15	110
NAS1149F0332P	7-5	430	NAS1149F0363P	7-20	150
NAS1149F0332P	7-5	880	NAS1149F0363P	12-5	700
NAS1149F0332P	7-9	100	NAS1149F0363P	12-10	290
NAS1149F0332P	7-10	600	NAS1149F0363P	12-11	320
NAS1149F0332P	7-15	60	NAS1149F0363P	12-12	220
NAS1149F0332P	7-16	160	NAS1149F0432P	3-11	360
NAS1149F0332P	7-17	150	NAS1149F0432P	3-20	390
NAS1149F0332P	12-5	140	NAS1149F0432P	3-20	460
NAS1149F0363P	11-8	320	NAS1149F0432P	3-20	540
NAS1149F0363P	11-9	245	NAS1149F0432P	3-20A	390
NAS1149F0363P	12-4	270	NAS1149F0432P	3-20A	460
NAS1149F0363P	12-4	–290	NAS1149F0432P	3-20A	540
NAS1149F0363P	3-11	140	NAS1149F0432P	3-20B	390
NAS1149F0363P	3-11	400	NAS1149F0432P	3-20B	460
NAS1149F0363P	3-11	90	NAS1149F0432P	3-20B	540
NAS1149F0363P	3-12	30	NAS1149F0432P	3-22	170
NAS1149F0363P	3-20	510	NAS1149F0432P	3-22	170
NAS1149F0363P	3-20A	510	NAS1149F0432P	3-29	120
NAS1149F0363P	3-20B	510	NAS1149F0432P	5-1	20
NAS1149F0363P	3-23	570	NAS1149F0432P	5-5	110
NAS1149F0363P	3-28	340	NAS1149F0432P	5-7	75
NAS1149F0363P	3-6	160	NAS1149F0432P	6-13	–
NAS1149F0363P	3-7	130	NAS1149F0432P	6-2	–
NAS1149F0363P	5-1	450	NAS1149F0432P	6-2	–
NAS1149F0363P	5-3	210	NAS1149F0432P	6-2	–
NAS1149F0363P	6-13	–	NAS1149F0432P	6-2	–
NAS1149F0363P	6-13	193	NAS1149F0432P	8-11	140
NAS1149F0363P	8-2	20	NAS1149F0432P	8-2	50
NAS1149F0363P	8-9	30	NAS1149F0432P	8-4	240
NAS1149F0363P	8-10	30	NAS1149F0432P	8-8	40
NAS1149F0363P	9-5	120	NAS1149F0432P	12-13	260

ENSTROM F-28/280 SERIES ILLUSTRATED PARTS CATALOG

PART NUMBER INDEX SECTIONS 3 THROUGH 7 AND 9 THROUGH 12 FIGURES 8-1 THROUGH 8-11

Part Number	Figure	Item	Part Number	Figure	Item
NAS1149F0432P	7-13	40	NAS1149F0532P	8-5	450
NAS1149F0432P	7-15	180	NAS1149F0532P	8-5A	100
NAS1149F0432P	7-16	210	NAS1149F0532P	7-20	80
NAS1149F0432P	7-17	240	NAS1149F0532P	7-20	–
NAS1149F0432P	7-19	90	NAS1149F0532P	7-21	20
NAS1149F0432P	7-20	110	NAS1149F0532P	12-5	220
NAS1149F0432P	7-22	80	NAS1149F0563P	8-4	170
NAS1149F0432P	12-5	360	NAS1149F0563P	12-7	–55
NAS1149F0463P	12-6	200	NAS1149F0563P	12-8	–230
NAS1149F0463P	3-11	350	NAS1149F0563P	4-1	60
NAS1149F0463P	3-22	280	NAS1149F0563P	4-2	360
NAS1149F0463P	3-23	300	NAS1149F0563P	5-1	420
NAS1149F0463P	4-4	160	NAS1149F0563P	5-2	90
NAS1149F0463P	4-4	310	NAS1149F0563P	5-4	220
NAS1149F0463P	5-1	280	NAS1149F0563P	8-3	30
NAS1149F0463P	5-3	390	NAS1149F0563P	8-5	440
NAS1149F0463P	5-4	400	NAS1149F0563P	8-6A	170
NAS1149F0463P	5-5	330	NAS1149F0563P	7-13	70
NAS1149F0463P	5-6	240	NAS1149F0563P	7-19	60
NAS1149F0463P	8-3	80	NAS1149F0563P	7-20	310
NAS1149F0463P	8-4	290	NAS1149F0563P	12-5	210
NAS1149F0463P	8-5	380	NAS1149F0632P	3-10	110
NAS1149F0463P	8-8	150	NAS1149F0632P	5-4	370
NAS1149F0463P	7-5	900	NAS1149F0632P	8-1	110
NAS1149F0463P	7-13	20	NAS1149F0632P	7-20	450
NAS1149F0463P	7-17	170	NAS1149F0663P	5-6	270
NAS1149F0463P	7-20	250	NAS1149F0663P	7-19	30
NAS1149F0463P	12-5	760	NAS1149F0732P	3-10	120
NAS1149F0463P	12-9	130	NAS1149F0732P	3-14	110
NAS1149F0463P	12-10	220	NAS1149F0732P	3-15	130
NAS1149F0532P	12-7	50	NAS1149F0732P	3-24	200
NAS1149F0532P	12-8	220	NAS1149F0732P	3-30	80
NAS1149F0532P	3-11	–	NAS1149F0732P	8-1	100
NAS1149F0532P	3-29	130	NAS1149F0763P	3-30	70
NAS1149F0532P	4-2	360	NAS1149F0763P	11-11	120
NAS1149F0532P	5-1	410	NAS1149F0763P	11-15	20
NAS1149F0532P	6-13	–	NAS1149F0763P	12-13	340
NAS1149F0532P	8-4	210	NAS1149F0763P	12-5	560

ENSTROM F-28/280 SERIES ILLUSTRATED PARTS CATALOG

PART NUMBER INDEX SECTIONS 3 THROUGH 7 AND 9 THROUGH 12 FIGURES 8-1 THROUGH 8-11

Part Number	Figure	Item	Part Number	Figure	Item
NAS1149F0763P	12-9	20	NAS1149FN616P	6-4	–
NAS1149F0763P	12-11	20	NAS1149FN616P	6-4	–
NAS1149F0763P	12-12	310	NAS1149FN616P	6-4	–
NAS1149F0863P	3-24	200	NAS1149FN616P	6-4	–
NAS1149F0863P	5-4	160	NAS1149FN616P	6-6	220
NAS1149F0963P	3-2	220	NAS1149FN616P	11-5	–
NAS1149F1232P	3-10	110	NAS1149FN616P	11-6	100
NAS1149F1232P	3-15	120	NAS1149FN616P	11-7	150
NAS1149F1232P	3-24	440	NAS1149FN616P	7-1	–
NAS1149FN316P	3-20	–	NAS1149FN616P	7-8	140
NAS1149FN316P	3-20	–	NAS1149FN616P	7-9	60
NAS1149FN316P	3-20	–	NAS1149FN616P	7-10	450
NAS1149FN316P	3-20A	–	NAS1149FN632P	3-20	350
NAS1149FN316P	3-20A	–	NAS1149FN632P	3-20A	350
NAS1149FN316P	3-20A	–	NAS1149FN632P	3-20B	350
NAS1149FN316P	3-20B	–	NAS1149FN632P	6-11	110
NAS1149FN316P	3-26	140	NAS1149FN632P	6-6	180
NAS1149FN316P	6-7	150	NAS1149FN632P	7-21	270
NAS1149FN416P	11-7	220	NAS1149FN816F	3-9	100
NAS1149FN416P	11-8	115	NAS1149FN816P	10-4	440
NAS1149FN416P	11-9	–	NAS1149FN816P	3-10	90
NAS1149FN416P	8-9	70	NAS1149FN816P	3-17	150
NAS1149FN416P	8-10	70	NAS1149FN816P	3-17	190
NAS1149FN416P	7-2	160	NAS1149FN816P	3-2	180
NAS1149FN616P	11-8	35	NAS1149FN816P	3-20	440
NAS1149FN616P	11-9	–	NAS1149FN816P	3-20	580
NAS1149FN616P	11-9	–	NAS1149FN816P	3-20A	440
NAS1149FN616P	11-9	–	NAS1149FN816P	3-20A	580
NAS1149FN616P	11-19	50	NAS1149FN816P	3-20B	440
NAS1149FN616P	3-16	90	NAS1149FN816P	3-20B	580
NAS1149FN616P	3-17	100	NAS1149FN816P	3-22	110
NAS1149FN616P	3-17	120	NAS1149FN816P	3-23	90
NAS1149FN616P	3-17	40	NAS1149FN816P	3-23	483
NAS1149FN616P	3-17	70	NAS1149FN816P	3-24	–
NAS1149FN616P	6-11	–	NAS1149FN816P	3-24	–
NAS1149FN616P	6-11	–	NAS1149FN816P	3-24	–
NAS1149FN616P	6-4	–	NAS1149FN816P	3-24	160
NAS1149FN616P	6-4	–	NAS1149FN816P	3-4	290

ENSTROM F-28/280 SERIES ILLUSTRATED PARTS CATALOG

PART NUMBER INDEX SECTIONS 3 THROUGH 7 AND 9 THROUGH 12 FIGURES 8-1 THROUGH 8-11

Part Number	Figure	Item	Part Number	Figure	Item
NAS1149FN816P	3-5	60	NAS1149FN816P	7-5	340
NAS1149FN816P	3-6	100	NAS1149FN816P	7-8	40
NAS1149FN816P	3-7	60	NAS1149FN816P	7-9	310
NAS1149FN816P	4-1	310	NAS1149FN816P	7-10	350
NAS1149FN816P	5-1	360	NAS1149FN816P	7-11	460
NAS1149FN816P	6-1	—	NAS1149FN816P	7-15	330
NAS1149FN816P	6-1	—	NAS1149FN816P	7-16	80
NAS1149FN816P	6-1	—	NAS1149FN816P	7-17	130
NAS1149FN816P	6-2	—	NAS1149FN832P	11-8	310
NAS1149FN816P	6-2	—	NAS1149FN832P	11-9	235
NAS1149FN816P	6-2	—	NAS1149FN832P	12-4	100
NAS1149FN816P	6-2	—	NAS1149FN832P	12-4	320
NAS1149FN816P	6-2	—	NAS1149FN832P	3-24	145
NAS1149FN816P	6-4	—	NAS1149FN832P	3-7	260
NAS1149FN816P	6-5	—	NAS1149FN832P	3-7	290
NAS1149FN816P	6-5	—	NAS1149FN832P	6-1	—
NAS1149FN816P	6-5	225	NAS1149FN832P	6-11	70
NAS1149FN816P	6-5	31	NAS1149FN832P	6-13	—
NAS1149FN816P	6-6	330	NAS1149FN832P	6-7	120
NAS1149FN816P	6-7	100	NAS1149FN832P	6-7	200
NAS1149FN816P	8-6	110	NAS1149FN832P	11-7	660
NAS1149FN816P	8-6A	50	NAS1149FN832P	11-11	190
NAS1149FN816P	8-9	120	NAS1149FN832P	7-1	160
NAS1149FN816P	8-10	120	NAS1149FN832P	7-8	120
NAS1149FN816P	11-14	120	NAS1149FN832P	12-9	220
NAS1149FN816P	11-15	80	NAS1351-3H10P	12-1	150
NAS1149FN816P	11-16	130	NAS13523H8P	3-3	350
NAS1149FN816P	11-17	160	NAS1352-3H8P	3-3	210
NAS1149FN816P	11-19	240	NAS-1368-N8A	7-14	260
NAS1149FN816P	11-19	85	NAS-1368-N8A	7-15	230
NAS1149FN816P	7-1	70	NAS-1368-N8A	7-16	300
NAS1149FN816P	7-1	—	NAS-1368-N8A	7-17	220
NAS1149FN816P	7-1	—	NAS-146-DH-22	7-13	120
NAS1149FN816P	7-1	650	NAS146DH24	7-13	100
NAS1149FN816P	7-1	—	NAS1523-4E	5-6	300
NAS1149FN816P	7-2	110	NAS1523-4E	5-7	70
NAS1149FN816P	7-4	190	NAS1611-010	3-26	80
NAS1149FN816P	7-5	190	NAS1611-025	4-4	110

ENSTROM F-28/280 SERIES ILLUSTRATED PARTS CATALOG

PART NUMBER INDEX SECTIONS 3 THROUGH 7 AND 9 THROUGH 12 FIGURES 8-1 THROUGH 8-11

Part Number	Figure	Item	Part Number	Figure	Item
NAS1611-025	4-4	40	NAS6603-22	7-15	280
NAS1611-029	4-2	140	NAS6603-22	7-16	30
NAS1611-137	4-4	150	NAS6603-22	7-17	260
NAS1611-326	4-4	90	NAS6603-24	8-5	310
NAS1611-333A	11-18	80	NAS6603-24	8-7	50
NAS1611-333A	12-4	50	NAS6603-24	7-15	100
NAS1612-10	4-4	240	NAS6603-24	7-16	40
NAS1612-2	4-4	250	NAS6603-24	7-17	310
NAS428-3A10	3-28	220	NAS6603-26	7-15	50
NAS428K4-16	3-11	180	NAS6603-26	7-17	140
NAS428K4-16	3-11	20	NAS6603-4	7-5	870
NAS428K4A16	3-11	20	NAS6603-4	7-9	90
NAS43HT3-48	5-5	270	NAS6603-4	7-15	240
NAS43HT4-64	3-20	550	NAS6603-4	7-16	150
NAS43HT4-64	3-20A	550	NAS6603-40	7-20	140
NAS43HT4-64	3-20B	550	NAS6603D14	3-11	460
NAS43HT4-64	3-7	380	NAS6603D16	3-11	420
NAS509-8	4-4	190	NAS6603D2	8-6A	130
NAS509-8	5-3	500	NAS6603D30	3-11	380
NAS559-3	4-4	180	NAS6603D4	12-3	70
NAS559-3	5-3	510	NAS6603D5	12-5	670
NAS561C8-10	5-5	60	NAS6603D6	12-7	190
NAS6205-8D	12-5	290	NAS6603D7	12-5	710
NAS620-6L	6-11	-	NAS6603D8	12-5	280
NAS626-58	4-3	90	NAS6603D9	12-5	850
NAS636A08	6-8	-	NAS6603H1	12-1	240
NAS636A08	6-8	-	NAS6603H1	12-5	600
NAS6603-1	8-5	240	NAS6604-1	7-13	30
NAS6603-10	3-11	130	NAS6604-1	12-10	180
NAS6603-12	12-4	280	NAS6604-11	7-17	340
NAS6603-14	11-8	290	NAS6604-11	8-8	140
NAS6603-14	11-7	610	NAS6604-13	8-8	30
NAS6603-16	3-26	200	NAS6604-17	7-13	50
NAS6603-17	12-5	160	NAS6604-17	7-19	80
NAS6603-18	8-5A	140	NAS6604-17	7-20	290
NAS66032	8-6	40	NAS6604-23	8-8	110
NAS66032	7-9	380	NAS6604-25	7-15	270
NAS6603-2	12-5	170	NAS6604-25	7-16	200

ENSTROM F-28/280 SERIES ILLUSTRATED PARTS CATALOG

PART NUMBER INDEX SECTIONS 3 THROUGH 7 AND 9 THROUGH 12 FIGURES 8-1 THROUGH 8-11

Part Number	Figure	Item	Part Number	Figure	Item
NAS6604-25	7-17	230	NAS6605-5	7-20	60
NAS6604-25	12-5	350	NAS6605-52	7-20	330
NAS6604-27	7-15	170	NAS6605-56	7-20	300
NAS6604-27	7-16	110	NAS6605D11	8-4	200
NAS6604-29	7-15	260	NAS6605D11	8-5	520
NAS6604-29	7-17	280	NAS6605D11	8-6A	160
NAS6604-3	12-13	280	NAS6605D13	8-3	20
NAS6604-3	12-12	250	NAS6605D13	8-5	510
NAS6604-40	7-20	550	NAS6605D15	8-5A	90
NAS6604-42	7-20	100	NAS6605D21	8-4	140
NAS6604-44	7-22	70	NAS6605D9	8-5	430
NAS6604-50	7-20	240	NAS6605D9	12-5	320
NAS6604-56	7-20	270	NAS6605H7	7-13	90
NAS6604-7	7-5	950	NAS6605H9	7-13	60
NAS6604-7	7-13	10	NAS6606D25	8-5A	60
NAS6604-9	8-8	70	NAS6607-5	12-13	350
NAS6604D11	8-4	230	NAS6607-5	12-9	10
NAS6604D15	12-6	10	NAS6607-5	12-11	10
NAS6604D15	12-5	730	NAS6607-5	12-12	320
NAS6604D15	12-10	250	NAS6607H5	12-5	570
NAS6604D17	12-6	190	NAS686A08K	3-20	-
NAS6604D17	8-3	70	NAS686A08K	3-20	-
NAS6604D17	12-5	770	NAS686A08K	3-20A	-
NAS6604D19	12-5	440	NAS686A08K	3-20B	-
NAS6604D21	3-11	330	NAS686A3K	3-20	-
NAS6604D23	8-5	370	NAS686A3K	3-20A	-
NAS6604D31	8-3A	310	NAS73-3-108	7-17	320
NAS6604D56	3-11	270	NAS73-3E002	3-28	360
NAS6604D7	12-2	90	NK 500-8-5	8-9	380
NAS6604D7	12-5	390	NK 500-8-5	8-10	380
NAS6604H1	12-13	270	NK4-7A	7-17	200
NAS6604H1	12-9	120	NK500-416-7	3-20	380
NAS6604H1	12-11	170	NK500-416-7	3-20A	380
NAS6604H1	12-12	240	NK500-416-7	3-20B	380
NAS6604H3	12-10	300	NK500-416-7	3-22	160
NAS6604H3	12-11	210	NK500-8-10	7-1	150
NAS6605-23	7-20	400	NK500-8-5	7-1	860
NAS6605-29	7-20	420	NK500-8-A/R	11-18	140

ENSTROM F-28/280 SERIES ILLUSTRATED PARTS CATALOG

PART NUMBER INDEX SECTIONS 3 THROUGH 7 AND 9 THROUGH 12 FIGURES 8-1 THROUGH 8-11

Part Number	Figure	Item	Part Number	Figure	Item
NK-500-8R6	4-1	150	PR1425B2	7-5	40
NK500-8-X	12-4	310	PS094032PG	3-26	150
NK501-10-6	11-18	135	PVC-13	11-8	500
NK501-10-6	12-4	260	PWMS-H25-C	6-14	60
NK509-8R6	12-11	130	Q30203DT	12-9	160
NK-510-10R10	4-1	250	QS100-M12S	3-3	130
NK525-1032R12	7-5	650	QS100-M28	3-28	200
NK525-10R10	3-24	40	QS100-M28S	10-2	19
NK525-10R12	3-24	40	QS100-M52S	3-5	110
NK525-10R12	7-5	980	QS200-M10S	3-5	30
NK525-832R10	7-5	800	QS200-M24S	3-5A	40
NK-525-8R8	7-11	350	QS200-M24S	3-5A	60
NO NUMBER	11-15	65	QS200-M28S	10-4	380
NO NUMBER	11-1	20	QS200-M40S	10-3	18
NO NUMBER	11-3	240	QS200-M40S	10-4	370
NP138BS1032-N-8Z	12-12	100	QS200-M40S	10-4	40
NP500-456-7	3-20	380	QS200-M40S	3-22	200
NP500-456-7	3-20A	380	QS-200-M40S	10-2	24
NP500-456-7	3-20B	380	QS200M44S	10-2	4
NP500-456-7	3-22	160	QS200-M44S	10-3	9
NP500-465-7	3-23	160	QS200-M44S	10-4	110
NP500-8R6	4-2	220	QS200-M44S	10-4	330
NP500-8R8	4-2	30	QS200-M44S	10-4	40
NP500-8-X	12-4	310	QS200-M44S	3-1	110
NP501-10-6	12-4	260	QS200-M44S	3-2	60
NP525-10R10	3-24	40	R10-E6-X2-V700	6-11	270
NP525-10R10	7-4	460	R10-E6-Y2-V185	6-11	270
NP525-10R12	3-24	40	R1224S-28	6-2	10B
NP525-10R12	7-4	650	R35M	6-10	10
NPN	6-4	80	RA4400-6-C	5-5	290
NS35649-262	6-11	-	RG24-11M	6-10	10
NSN 5305-00-984-6208	3-1	60	RG24-11M	6-13	80
PACMO-APZ2IN	11-8	480	RG-35	6-10	10
PAI-700	11-5	260	RHB32S	3-31	-
PAI-700 28V	11-8	475	RJ-0370	3-8	150
PGZF0A0180	4-4	90	RJ-1045-2	3-8	110
PLT4S-CO	11-7	-	RJ9700	3-3	220
PR1425B1/2	7-5	40	RST-200	4-2	120

ENSTROM F-28/280 SERIES ILLUSTRATED PARTS CATALOG

PART NUMBER INDEX SECTIONS 3 THROUGH 7 AND 9 THROUGH 12 FIGURES 8-1 THROUGH 8-11

Part Number	Figure	Item	Part Number	Figure	Item
S10P-175	3-24	60	SL61W-5P	12-10	20
S10P-175	3-24	60	SL61W-5P	12-11	250
S10P-175	7-4	370	SL61W-5P	12-12	170
S10P-320	3-24	60	SLN-3045	5-4	350
S-12B	9-2	36	SLW-3045	5-4	-
S4-200	3-2	113	SST1.5I-M	12-2	130
S4-200	7-1	550	SST1.5I-MP	11-7	850
S500-10	11-19	160	SST1.5I-MP	11-8	390
S500-12	11-19	195	SST1.5I-MP	11-9	300
S500-16	11-19	100	SST1.5I-MP	11-17	200
S500-3	11-19	210	SST1M-MP	6-12	100
S500-4	11-19	75	SST1M-MP	11-17	190
S500-6	11-19	200	SST25-MP	8-5	580
S-50MP	5-6	50	SST2S-MP	11-7	840
S6P-270	7-4	50	SST2S-MP	11-8	385
S83BZ-2	12-1	90	SST2S-MP	11-9	295
S8P-150	11-20	110	SST2S-MP	11-16	150
S8P-150	7-10	220	SST2S-MP	11-17	210
S8P270	9-3	310	STD-1410	3-27	-
S8P270	9-4	270	STD-1410	3-28	170
SAW4204-15-123	6-1	20	STD-2233	3-28	160
SAZ-4201E	6-2	30	STD-2233	3-28	170
SAZ-4401	6-2	30	STD-35	3-27	-
SAZ-4401-1	6-13	170	STD-35	3-28	150
SAZ-4401-1	6-2	30	STD-475	3-27	-
SC616NJ	6-11	130	STD-475	3-28	160
SC628ANPR	6-11	130	SY-0211	9-2	33
SCEET 7	3-5A	50	T14BH517BC	11-5	-
SCEET 7	3-5A	80	TIGK54-15-RD-A	11-6	510
SJ-3501	11-20	130	TIGK54-15-WH-A	11-6	500
SL1N-4	12-9	140	TIGK54-1S-RD-A	11-5	160A
SL61N-5F	12-13	170	TIGK54-1S-WH-A	11-5	160B
SL61N-5P	12-13	170	TIGM54-1C-RD-A	11-2	10
SL61N-5P	12-10	30	TIGM54-1C-RD-A	11-3	10
SL61N-5P	12-11	260	TIGM54-1C-WH-A	11-2	-20A
SL61N-5P	12-12	160	TIGM54-1C-WH-A	11-3	-20A
SL61W-4	12-9	150	TILA64-1C-RD-A	11-2	-10A
SL61W-5P	12-13	180	TILA64-1C-WH-A	11-2	20

ENSTROM F-28/280 SERIES ILLUSTRATED PARTS CATALOG

PART NUMBER INDEX SECTIONS 3 THROUGH 7 AND 9 THROUGH 12 FIGURES 8-1 THROUGH 8-11

Part Number	Figure	Item	Part Number	Figure	Item
TILA64-1C-WH-A	11-3	20	W-1290-28	6-6	390
TS-023	12-7	70	W1819-020	12-8	110
TS-023	12-8	100	W1819-020	12-5	-
TS-023	12-8	130	W33-7516-10ET-1	11-5	320
TS-023	12-5	-	W97CSX-2	6-7	190
TS-023	12-5	580	WC-22-6	4-3	100
U16082-H61	11-4	40	WP-22-6	4-3	110
UI-5934-1	11-5	60	X1333HT	7-4	230
UI5934-3	11-6	120	X-142	4-2	-
UI6082-H61	11-1	150	X1543HT	7-6	-280
V3-1	8-9	50	X-1567	7-20	-
V3-1	8-10	50	X-16799	6-1	140
VC-3	5-2	-	X-16799	6-2	50
VC-3	12-5	-	Y9485	11-8	180
VH-375	5-6	246	Y9485	3-2	-
VH-75	4-2.1	170	Y9485	11-7	60
VSF-7203	6-1	90	Y9485	7-4	510
VSF-7403T	6-2	10	Z99R6	8-9	280
W-09	4-1	190	Z99R6	8-10	280
W-09	4-3	20	Z9R4X3	8-9	170
W-1284-G	6-6	120A	Z9R4X3	8-10	170
W-1284-R	6-6	120	ZX-10204	7-4	230
W-1290-14	6-6	390			

ENSTROM F-28/280 SERIES ILLUSTRATED PARTS CATALOG

I

INTENTIONALLY LEFT BLANK

ENSTROM F-28/280 SERIES ILLUSTRATED PARTS CATALOG

SECTION 3 POWER PLANT

TABLE OF CONTENTS

	Cover Page	3-1
	Table of Contents	3-1
3-1	Air Induction System (F-28A)	3-2
3-2	Air Induction System	3-4
3-3	Turbocharger Induction System	3-8
3-4	Fuel Nozzle Air Vent System	3-13
3-5	Engine Vent Installation	3-16
3-5A	Magneto Cooling Installation	3-18
3-6	Oil Cooler Installation (A Models)	3-21
3-7	Oil Cooler Installation (C, F Models)	3-24
3-8	Turbocharger Oil Lines	3-28
3-9	Oil Fill Tube Installation	3-31
3-10	Throttle and Mixture Control Installation (A, C Models)	3-34
3-11	Throttle Correlator Assembly (F Models)	3-40
3-12	Throttle Correlator Installation (F Models)	3-44
3-13	Dual Throttle Control Installation (F Models)	3-46
3-14	Throttle Cable Installation (F Models)	3-48
3-15	Mixture Cable Installation (F Models)	3-50
3-16	Fire Curtain Assembly (All Models)	3-53
3-17	Fire Curtain Installation (All Models)	3-55
3-18	Engine Fan Shroud Assembly (A Models)	3-59
3-19	Engine Fan Shroud Assembly (C Models)	3-63
3-20/A/B	Engine Fan Shroud Assembly (C, F Models)	3-66
3-21	Cooling Fan and Alternator Installation	3-96
3-22	Engine Fuel System (A Models)	3-98
3-23	Engine Fuel System (C, F Models)	3-103
3-24	Main Fuel System	3-108
3-25	Fuel Level Sending Unit	3-115
3-26	Fuel Shutoff Valve Assembly	3-117
3-27	Exhaust System Installation (A Models)	3-120
3-28	Exhaust System Installation (C, F Models)	3-122
3-29	Turbocharger Mount Installation	3-127
3-30	Engine Mount Assembly	3-130
3-31	Engine Components	3-132

ENSTROM F-28/280 SERIES ILLUSTRATED PARTS CATALOG

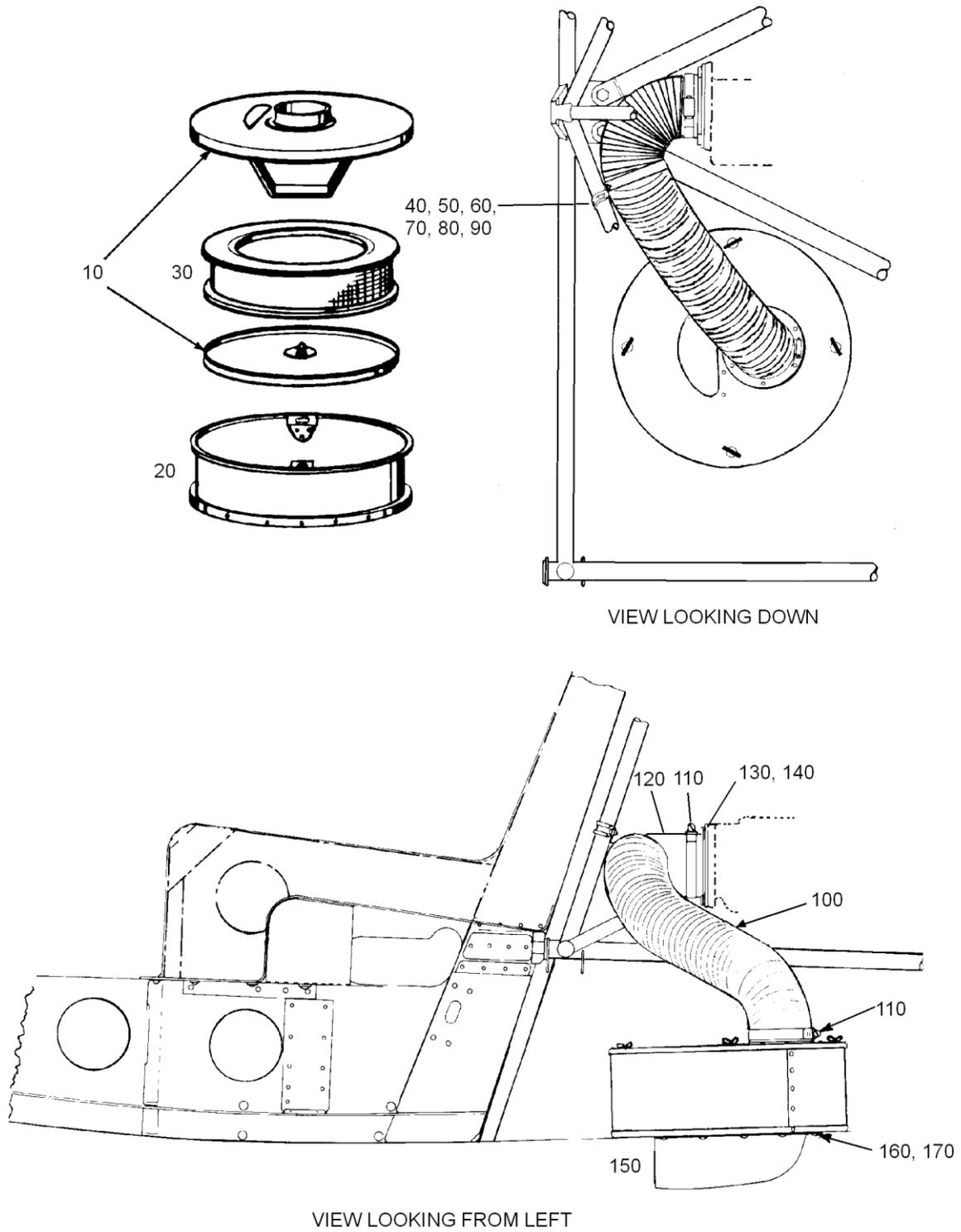

FIGURE 3-1. AIR INDUCTION SYSTEM (F-28A)

ENSTROM F-28/280 SERIES ILLUSTRATED PARTS CATALOG

FIGURE 3-5. ENGINE VENT INSTALLATION

ITEM NUMBER	PART NUMBER	DESCRIPTION	QTY PER ASSY	MODELS AFFECTED						
				F-28A	280	F-28C	280C	F-28F	280F	280FX
10	28-12145-1	. Breather Vent Hose	1	X	X	X	X	X	X	X
20	28-12140-1	. Breather Vent Tube	1	X	X	X	X	X	X	X
30	QS200-M10S	. Clamp	2	X	X	X	X	X	X	X
40	MS21919WDF12	. Clamp	2	X	X	X	X	X	X	X
50	MS35206-246	. Screw	1	X	X	X	X	X	X	X
50	AN515-8R10	. Screw (Superseded by MS35206-246)	1	X	X	X	X	X	X	X
60	NAS1149FN816P	. Washer	2	X	X	X	X	X	X	X
60	AN960-8L	. Washer (Superseded by NAS1149FN816P)	2	X	X	X	X	X	X	X
70	MS35338-42	. Lock Washer	1	X	X	X	X	X	X	X
70	AN935-8	. Lock Washer (Superseded by MS35338-42)	1	X	X	X	X	X	X	X
80	MS35649-282	. Nut	1	X	X	X	X	X	X	X
80	AN340-8	. Nut (Superseded by MS35649-282)	1	X	X	X	X	X	X	X
90*	LW-13807	. Sniffer Valve Assembly	2			X	X	X	X	X
-	MS28775-015	. . O-Ring (Inside Sniffer Valve)	2			X	X	X	X	X
100	28-121000-19	. . Sniffer Valve Drain Tube	2	X	X	X	X	X	X	X
110	QS100-M52S	. Clamp	2	X	X	X	X	X	X	X

* Obtain from Lycoming distributor.

ENSTROM F-28/280 SERIES ILLUSTRATED PARTS CATALOG

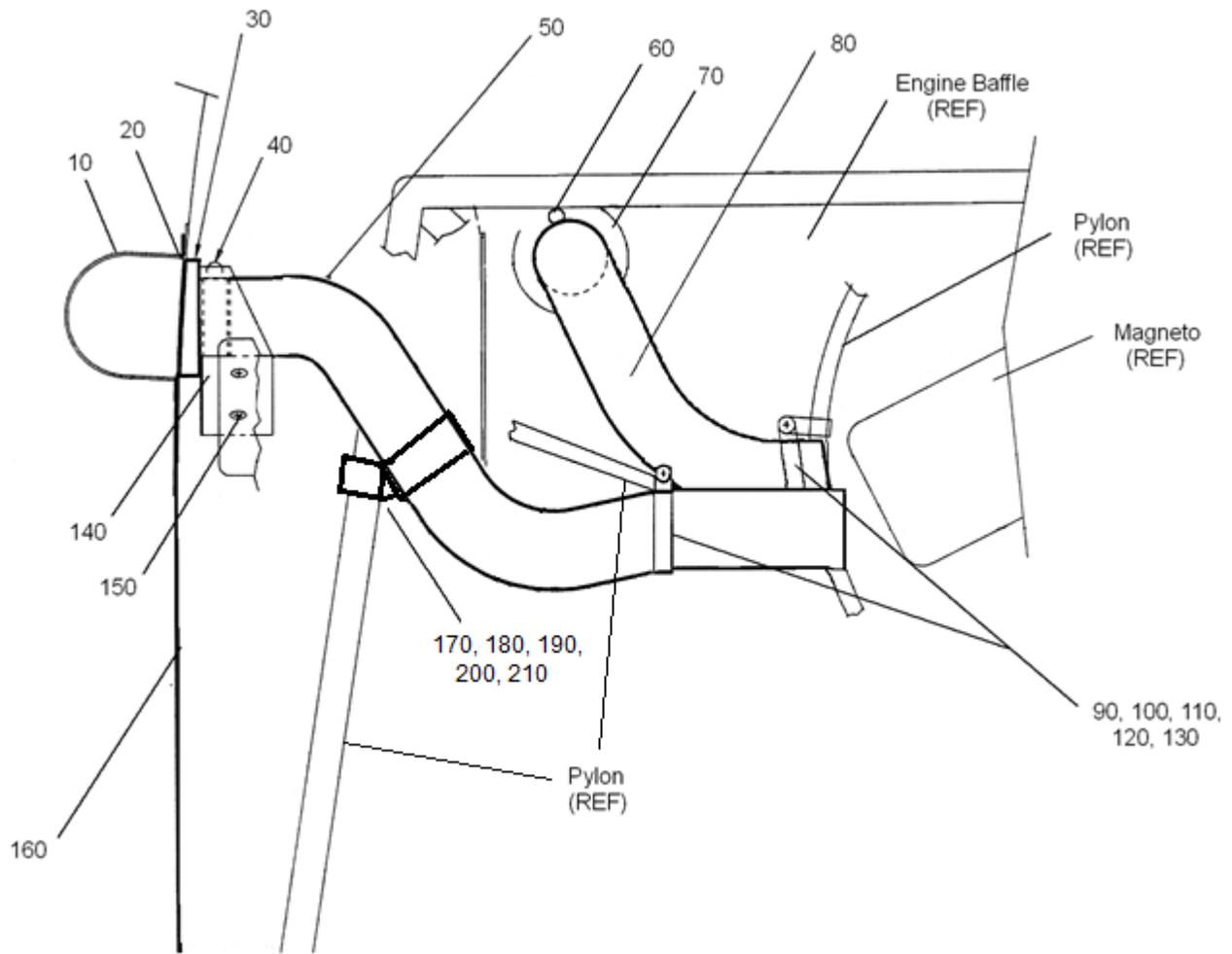

FIGURE 3-5A. MAGNETO COOLING INSTALLATION

ENSTROM F-28/280 SERIES ILLUSTRATED PARTS CATALOG

FIGURE 3-5A. MAGNETO COOLING INSTALLATION

ITEM NUMBER	PART NUMBER	DESCRIPTION	QTY PER ASSY	MODELS AFFECTED						
				F-28A	280	F-28C	280C	F-28F	280F	280FX
-*	28-22031-1	Magneto Blast Tube Install Magneto Cooling	REF			X	X	X	X	X
10	28-12706-11	. . Deflector - Hot Air	1			X	X	X	X	X
20	MS20470AD3-3	. . Rivet: Solid, 3/32" X 0.188"	6			X	X	X	X	X
30	28-22034-11	. Seal Foam Magneto	1			X	X	X	X	X
40	QS200-M24S	. Clamp, Hose, 1.0625-2.0" Dia	2			X	X	X	X	X
50	400-003	. Duct, Silicone/Fiberglass, 1.750"	24"			X	X	X	X	X
50	SCEET 7	. Duct, Silicone/Fiberglass, 1.750" (Superseded by 400-003)	24"			X	X	X	X	X
60	QS200-M24S	. Clamp, Hose, 1.0625-2.0" Dia	2			X	X	X	X	X
70	280-127505-17	. Stub Heat Duct	1			X	X	X	X	X
80	400-003	. Duct, Silicone/Fiberglass, 1.750"	12"			X	X	X	X	X
80	SCEET 7	. Duct, Silicone/Fiberglass, 1.750" (Superseded by 400-003)	12"			X	X	X	X	X
90	AN742D28	. Clamp, Loop	2			X	X	X	X	X
100	MS21919WDG14	. Clamp, Loop	2			X	X	X	X	X
110	MS35207-262	. Screw, Mach (Ph), 10-32 X 0.438	2			X	X	X	X	X
120	NAS1149F0332P	. Washer, Flat	2			X	X	X	X	X
130	MS21083N3	. Nut: Hex, 190-32 UNJF-3B Thin	2			X	X	X	X	X
140	28-01058-3	. Cooling Kit Assy	1			X	X	X	X	X
-	28-01058-15	. . Bracket Magneto Cooling	1			X	X	X	X	X
150	AN526-1032R8	. . Screw, Mach (Th) 10-32 x 0.500	2			X	X	X	X	X
160	28-22032-1	. Cowl Lower Center 280FX	1			X	X	X	X	X
160	28-114016-7	. Cowl Lower Center F28F	1			X	X	X	X	X
170	AN742D28	. Clamp	1	X	X	X	X	X	X	X
180	MS21919WDG12	. Clamp	1	X	X	X	X	X	X	X
190	MS35207-262	. Screw	1	X	X	X	X	X	X	X

ENSTROM F-28/280 SERIES ILLUSTRATED PARTS CATALOG

FIGURE 3-5A. MAGNETO COOLING INSTALLATION

ITEM NUMBER	PART NUMBER	DESCRIPTION	QTY PER ASSY	MODELS AFFECTED						
				F-28A	280	F-28C	280C	F-28F	280F	280FX
200	NAS1149F0332P	. Washer	1	X	X	X	X	X	X	X
210	MS21083N3	. Nut	1	X	X	X	X	X	X	X

* Customer Service use (excludes P/N 280-127505).

ENSTROM F-28/280 SERIES ILLUSTRATED PARTS CATALOG

FIGURE 3-20. ENGINE FAN SHROUD ASSEMBLY
F-28F S/N 826 and 280FX S/N 2135 and Subsequent

ITEM NUMBER	PART NUMBER	DESCRIPTION	QTY PER ASSY	MODELS AFFECTED						
				F-28A	280	F-28C	280C	F-28F	280F	280FX
-	G-89	. . Fabric: Fire Curtain, 0.057" Thick (In square yards)	0.002					X		X
-	MS20470A3-3	. . Rivet, Solid, 3/32" X 0.188"	6					X		X
-	NAS1149FN316P	. . Washer: Flat, #3 (0.016") Light	6					X		X
-	AN960-3	. . Washer (Superseded by NAS 1149FN316P)	6					X		X
-	MS21069-06	. . Nut Plate	5					X		X
-	MS20426AD3-3	. . Rivet, Solid, 3/32" X 3/16"	10					X		X
330	28-126008-3	. Plate Baffle Assembly	1					X		X
330	28-126008-1	. Plate Baffle Assembly (Superseded by 28-126008-3)	1					X		X
-	82-35-302-15	. . Receptacle, Spring, Leaf #82	1					X		X
-	MS21069-06	. . Nut Plate	3					X		X
-	NAS1097AD3-3	. . Rivet	2					X		X
-	NAS1097AD3-4	. . Rivet: Solid, 3/32" X 1/4"	10					X		X
-	28-12608-4	. . Tab Support	1					X		X
-	28-12621-1	. . Bracket Cover	1					X		X
-	28-181008-1	. . Ducting Stub	1					X		X
340	AN515-6-6	. Screw, Machine (RH), 6-32 X 0.375"	A/R					X		X
350	NAS1149FN632P	. Washer, Flat #6 Bolt Size	A/R					X		X
350	AN960-6	. Washer (Superseded by NAS1149FN632P)	A/R					X		X
360	MS35338-41	. Washer, Lock, #6 (0.031")	A/R					X		X
360	AN935-6	. Lock Washer (Superseded by MS35338-41)	A/R					X		X
370	MS35649-262	. Nut, Hex, 6-32 Light	A/R					X		X
370	AN340-632	. Nut (Superseded by MS35649-262)	A/R					X		X
380	NP500-456-7	. Screw, 1/4-20 X 7/16"	3					X		X
380	NK500-416-7	. Screw (Superseded by NP500-456-7)	3					X		X
390	NAS1149F0432P	. Washer: Flat, 1/4" (0.032) Light	3					X		X

ENSTROM F-28/280 SERIES ILLUSTRATED PARTS CATALOG

FIGURE 3-20. ENGINE FAN SHROUD ASSEMBLY
F-28F S/N 826 and 280FX S/N 2135 and Subsequent

ITEM NUMBER	PART NUMBER	DESCRIPTION	QTY PER ASSY	MODELS AFFECTED						
				F-28A	280	F-28C	280C	F-28F	280F	280FX
390	AN960-416L	. Washer (Superseded by NAS1149F0432P)	3					X		X
400	AN502-10-8	. Screw	3					X		X
410	MS35333-39	. Lock Washer	3					X		X
410	AN936A10	. Lock Washer (Superseded by MS35333-39)	3					X		X
420*	65614	. Plug, Attaching	3					X		X
430	MS35206-244	. Screw, Machine (RH), 8-32 X 0.438"	5					X		X
430	AN515-8R7	. Screw (Superseded by MS35206-244)	5					X		X
440	NAS1149FN816P	. Washer: Flat, #8" (0.016") Light	5					X		X
440	AN960-8L	. Washer (Superseded by NAS1149FN816P)	5					X		X
450	AN3-3A	. Bolt, Mach, 10-32 X 0.469"	A/R					X		X
460	NAS1149F0432P	. Washer, Flat, #10 (0.032") Light	A/R					X		X
460	AN960-10L	. Washer (Superseded by NAS1149F0332P)	A/R					X		X
470	AN3-4A	. Bolt: Machine, 10-32 X 0.531"	1					X		X
480	28-12619-1	. Strut Assembly	1					X		X
-	28-12619-4	. . Bracket End Lower	1							
-	28-12619-5	. . Plate, End, Fan Shroud Strut	1							
490	28-12686-11	. Strut	1					X		X
500	AN3-5A	. Bolt, Mach, 10-32 X 0.656"	1					X		X
510	NAS1149F0363P	. Washer, Flat, #10 (0.063")	2					X		X
510	AN960-10	. Washer (Superseded by NAS1149F0363P)	2					X		X
520	MS21044N3	. Nut, Self-Locking	1					X		X
520	AN365-1032A	. Nut (Superseded by MS21044N3)	1					X		X
530	AN503-416-10	. Screw, Machine (Flh), 1/4-20 X 0.625"	6					X		X
530	AN503-416-28	. Screw, Machine (Flh), 1/4-20 X 1.750"	2					X		X

ENSTROM F-28/280 SERIES ILLUSTRATED PARTS CATALOG

FIGURE 3-20 A. ENGINE FAN SHROUD ASSEMBLY
F28F S/N F 825 and 280FX S/N 2134 and Previous

ITEM NUMBER	PART NUMBER	DESCRIPTION	QTY PER ASSY	MODELS AFFECTED						
				F-28A	280	F-28C	280C	F-28F	280F	280FX
-	MS21071-06	. . Nut Plate	1					X		X
-	MS21069-06	. . Nut Plate	1					X		X
-	NAS1097AD3-4	. . Rivet	2					X		X
-	280-127505-17	. . Stub Heat Duct	1					X		X
-	MS20470AD3-4	. . Rivet, Solid, 3/32" X 0.250"	4					X		X
-	NAS1097AD3-3	. . Rivet	4					X		X
320	28-12617-1	. Plate Baffle Assembly	1					X		X
-	G-89	. . Fabric: Fire Curtain, 0.057" Thick (In square yards)	0.002					X		X
-	MS20470A3-3	. . Rivet, Solid, 3/32" X 0.188"	6					X		X
-	NAS1149FN316P	. . Washer: Flat, #3 (0.016") Light	6					X		X
-	AN960-3	. . Washer (Superseded by NAS 1149FN316P)	6					X		X
-	MS21069-06	. . Nut Plate	5					X		X
-	MS20426AD3-3	. . Rivet, Solid, 3/32" X 3/16"	10					X		X
330	28-126008-3	. Plate Baffle Assembly	1					X		X
330	28-126008-1	. Plate Baffle Assembly (Superseded by 28-126008-3)	1					X		X
-	82-35-302-15	. . Receptacle, Spring, Leaf #82	1					X		X
-	MS21069-06	. . Nut Plate	3					X		X
-	NAS1097AD3-3	. . Rivet	2					X		X
-	NAS1097AD3-4	. . Rivet: Solid, 3/32" X 1/4"	10					X		X
-	28-12608-4	. . Tab Support	1					X		X
-	28-12621-1	. . Bracket Cover	1					X		X
-	28-181008-1	. . Ducting Stub	1					X		X
340	AN515-6-6	. Screw, Machine (RH), 6-32 X 0.375"	A/R					X		X
350	NAS1149FN632P	. Washer, Flat #6 Bolt Size	A/R					X		X
350	AN960-6	. Washer (Superseded by NAS1149FN632P)	A/R					X		X
360	MS35338-41	. Washer, Lock, #6 (0.031")	A/R					X		X

ENSTROM F-28/280 SERIES ILLUSTRATED PARTS CATALOG

FIGURE 3-20 A. ENGINE FAN SHROUD ASSEMBLY
F28F S/N 825 and 280FX S/N 2134 and Previous

ITEM NUMBER	PART NUMBER	DESCRIPTION	QTY PER ASSY	MODELS AFFECTED						
				F-28A	280	F-28C	280C	F-28F	280F	280FX
360	AN935-6	. Lock Washer (Superseded by MS35338-41)	A/R					X		X
370	MS35649-262	. Nut, Hex, 6-32 Light	A/R					X		X
370	AN340-632	. Nut (Superseded by MS35649-262)	A/R					X		X
380	NP500-456-7	. Screw, 1/4-20 X 7/16"	3					X		X
380	NK500-416-7	. Screw (Superseded by NP500-456-7)	3					X		X
390	NAS1149F0432P	. Washer: Flat, 1/4" (0.032") Light	3					X		X
390	AN960-416L	. Washer (Superseded by NAS1149F0432P)	3					X		X
400	AN502-10-8	. Screw	3					X		X
410	MS35333-39	. Lock Washer	3					X		X
410	AN936A10	. Lock Washer (Superseded by MS35333-39)	3					X		X
420*	65614	. Plug, Attaching	3					X		X
430	MS35206-244	. Screw, Machine (RH), 8-32 X 0.438"	5					X		X
430	AN515-8R7	. Screw (Superseded by MS35206-244)	5					X		X
440	NAS1149FN816P	. Washer: Flat, #8" (0.016) Light	5					X		X
440	AN960-8L	. Washer (Superseded by NAS1149FN816P)	5					X		X
450	AN3-3A	. Bolt, Mach, 10-32 X 0.469"	A/R					X		X
460	NAS1149F0432P	. Washer, Flat, #10 (0.032") Light	A/R					X		X
460	AN960-10L	. Washer (Superseded by NAS1149F0332P)	A/R					X		X
470	AN3-4A	. Bolt: Machine, 10-32 X 0.531"	1					X		X
480	28-12619-1	. Strut Assembly	1					X		X
-	28-12619-4	. Bracket End Lower	1							
-	28-12619-5	. Plate, End, Fan Shroud Strut	1							
490	28-12686-11	. Strut	1					X		X
500	AN3-5A	. Bolt, Mach, 10-32 X 0.656"	1					X		X
510	NAS1149F0363P	. Washer, Flat, #10 (0.063")	2					X		X

ENSTROM F-28/280 SERIES ILLUSTRATED PARTS CATALOG

FIGURE 3-20 A. ENGINE FAN SHROUD ASSEMBLY
F28F S/N F28F 825 and 280FX S/N 2134 and Previous

ITEM NUMBER	PART NUMBER	DESCRIPTION	QTY PER ASSY	MODELS AFFECTED						
				F-28A	280	F-28C	280C	F-28F	280F	280FX
510	AN960-10	. Washer (Superseded by NAS1149F0363P)	2					X		X
510	NAS1149F0363P	. Washer, Flat, #10 (0.063")	2					X		X
510	AN960-10	. Washer (Superseded by NAS1149F0363P)	2					X		X
520	MS21044N3	. Nut, Self-Locking	1					X		X
520	AN365-1032A	. Nut (Superseded by MS21044N3)	1					X		X
530	AN503-416-10	. Screw, Machine (Flh), 1/4-20 X 0.625"	6					X		X
530	AN503-416-28	. Screw, Machine (Flh), 1/4-20 X 1.750"	2					X		X
540	NAS1149F0432P	. Washer: Flat, 1/4" (0.032") Light	8					X		X
540	AN960-416L	. Washer (Superseded by NAS1149F0432P)	8					X		X
550	NAS43HT4-64	. Spacer	2					X		X
560	MS21919WCJ12	. Clamp, Loop, 3/4" Cushioned	3					X		X
565	AN526-1032R8	. Screw	1							
570	MS35206-245	. Screw: Mach (Ph), 8-32 X 0.500"	8					X		X
570	AN515-8R8	. Screw (Superseded by MS35206-245)	8					X		X
575	NAS1149F0332P	. Washer	1					X		X
580	NAS1149FN816P	. Washer: Flat, #8" (.016") Light	16					X		X
580	AN960-8L	. Washer (Superseded by NAS1149FN816P)	16					X		X
585	AN935-10	. Lock Washer	1					X		X
590	MS35338-42	. Washer: Lock, 0.040" #8 Light	7					X		X
590	AN935-8	. Lock Washer (Superseded by MS35338-42)	7					X		X
600	MS35649-282	. Nut: Hex, 8-32 Unc-2b Light	8					X		X
600	AN340-8	. Nut (Superseded by MS35649-282)	8					X		X
610	280-126001-69	. Bracket, Clamp, Support	3					X		X
620	AN742-F6	. Clamp	1					X		X

ENSTROM F-28/280 SERIES ILLUSTRATED PARTS CATALOG

FIGURE 3-20 A. ENGINE FAN SHROUD ASSEMBLY
F28F S/N F28F 825 and 280FX S/N 2134 and Previous

ITEM NUMBER	PART NUMBER	DESCRIPTION	QTY PER ASSY	MODELS AFFECTED						
				F-28A	280	F-28C	280C	F-28F	280F	280FX
630	4508-2	. Tape: Foam, 2"W (0.125" T) Black	82"					X		X

* Obtain from a Lycoming distributor.

NOTE 1 Parts listed are for both 28-12676-7 and 28-12676 -9 assemblies unless otherwise noted.

** Effectivity F-28F S/N 830 and subsequent. Effectivity 280FX S/N 2137 and subsequent. Retrofittable to F-28F S/N 509 and 280FX S/N 2001.

• Effectivity F-28F S/N 805 and subsequent. Effectivity 280FX S/N 2080 and subsequent.

•• Eligibility F-28F S/N 509-825 and 280FX S/N 2001-2134.

ENSTROM F-28/280 SERIES ILLUSTRATED PARTS CATALOG

FIGURE 3-20 B. ENGINE FAN SHROUD ASSEMBLY

Early Models

ITEM NUMBER	PART NUMBER	DESCRIPTION	QTY PER ASSY	MODELS AFFECTED						
				F-28A	280	F-28C	280C	F-28F	280F	280FX
-	MS21069-06	. . Nut Plate	1			X	X	X	X	X
-	NAS1097AD3-4	. . Rivet	2			X	X	X	X	X
-	280-127505-17	. . Stub Heat Duct	1			X	X	X	X	X
-	MS20470AD3-4	. . Rivet, Solid, 3/32" X 0.250"	4			X	X	X	X	X
-	NAS1097AD3-3	. . Rivet	4			X	X	X	X	X
320	28-12617-1	. Plate Baffle Assembly	1			X	X	X	X	X
-	G-89	. . Fabric: Fire Curtain, 3/64" Thick (In square yards)	0.002			X	X	X	X	X
-	MS20470A3-3	. . Rivet, Solid, 3/32" X 0.188"	6			X	X	X	X	X
-	NAS1149FN316P	. . Washer: Flat, #3 (0.016") Light	6			X	X	X	X	X
-	AN960-3	. . Washer (Superseded by NAS 1149FN316P)	6			X	X	X	X	X
-	MS21069-06	. . Nut Plate	5			X	X	X	X	X
-	MS20426AD3-3	. . Rivet, Solid, 3/32" X 3/16"	10			X	X	X	X	X
330	28-126008-3	. Plate Baffle Assembly	1			X	X	X	X	X
330	28-126008-1	. Plate Baffle Assembly (Superseded by 28-126008-3)	1			X	X	X	X	X
-	82-35-302-15	. . Receptacle, Spring, Leaf #82	1			X	X	X	X	X
-	MS21069-06	. . Nut Plate	3			X	X	X	X	X
-	NAS1097AD3-3	. . Rivet	2			X	X	X	X	X
-	NAS1097AD3-4	. . Rivet: Solid, 3/32" X 1/4"	10			X	X	X	X	X
-	28-12608-4	. . Tab Support	1			X	X	X	X	X
-	28-12621-1	. . Bracket Cover	1			X	X	X	X	X
-	28-181008-1	. . Ducting Stub	1			X	X	X	X	X
340	AN515-6-6	. Screw, Machine (RH), 6-32 X 0.375"	A/R			X	X	X	X	X
350	NAS1149FN632P	. Washer, Flat #6 Bolt Size	A/R			X	X	X	X	X
350	AN960-6	. Washer (Superseded by NAS1149FN632P)	A/R			X	X	X	X	X
360	MS35338-41	. Washer, Lock, #6 (0.031")	A/R			X	X	X	X	X
360	AN935-6	. Lock Washer (Superseded by MS35338-41)	A/R			X	X	X	X	X

ENSTROM F-28/280 SERIES ILLUSTRATED PARTS CATALOG

FIGURE 3-20 B. ENGINE FAN SHROUD ASSEMBLY

Early Models

ITEM NUMBER	PART NUMBER	DESCRIPTION	QTY PER ASSY	MODELS AFFECTED						
				F-28A	280	F-28C	280C	F-28F	280F	280FX
370	MS35649-262	. Nut, Hex, 6-32 Light	A/R			X	X	X	X	X
370	AN340-632	. Nut (Superseded by MS35649-262)	A/R			X	X	X	X	X
380	NP500-456-7	. Screw, 1/4-20 X 7/16"	3			X	X	X	X	X
380	NK500-416-7	. Screw (Superseded by NP500-456-7)	3			X	X	X	X	X
390	NAS1149F0432P	. Washer: Flat, 1/4" (0.032") Light	3			X	X	X	X	X
390	AN960-416L	. Washer (Superseded by NAS1149F0432P)	3			X	X	X	X	X
400	AN502-10-8	. Screw	3			X	X	X	X	X
410	MS35333-39	. Lock Washer	3			X	X	X	X	X
410	AN936A10	. Lock Washer (Superseded by MS35333-39)	3			X	X	X	X	X
420*	65614	. Plug, Attaching	3			X	X	X	X	X
430	MS35206-244	. Screw, Machine (RH), 8-32 X 0.438"	5			X	X	X	X	X
430	AN515-8R7	. Screw (Superseded by MS35206-244)	5			X	X	X	X	X
440	NAS1149FN816P	. Washer: Flat, #8" (0.016") Light	5			X	X	X	X	X
440	AN960-8L	. Washer (Superseded by NAS1149FN816P)	5			X	X	X	X	X
450	AN3-3A	. Bolt, Mach, 10-32 X 0.469"	A/R			X	X	X	X	X
460	NAS1149F0432P	. Washer, Flat, #10 (0.032") Light	A/R			X	X	X	X	X
460	AN960-10L	. Washer (Superseded by NAS1149F0332P)	A/R			X	X	X	X	X
470	AN3-4A	. Bolt: Machine, 10-32 X 0.531"	1			X	X	X	X	X
480	28-12619-1	. Strut Assembly	1			X	X	X	X	X
-	28-12619-4	. . Bracket End Lower	1							
-	28-12619-5	. . Plate, End, Fan Shroud Strut	1							
490	28-12686-11	. Strut	1			X	X	X	X	X
500	AN3-5A	. Bolt, Mach, 10-32 X 0.656"	1			X	X	X	X	X
510	NAS1149F0363P	. Washer, Flat, #10 (0.063")	2			X	X	X	X	X

ENSTROM F-28/280 SERIES ILLUSTRATED PARTS CATALOG

FIGURE 3-20 B. ENGINE FAN SHROUD ASSEMBLY

Early Models

ITEM NUMBER	PART NUMBER	DESCRIPTION	QTY PER ASSY	MODELS AFFECTED						
				F-28A	280	F-28C	280C	F-28F	280F	280FX
510	AN960-10	. Washer (Superseded by NAS1149F0363P)	2			X	X	X	X	X
520	MS21044N3	. Nut, Self-Locking	1			X	X	X	X	X
520	AN365-1032A	. Nut (Superseded by MS21044N3)	1			X	X	X	X	X
530	AN503-416-10	. Screw, Machine (Flh), 1/4-20 X 0.625"	6			X	X	X	X	X
530	AN503-416-28	. Screw, Machine (Flh), 1/4-20 X 1.750"	2			X	X	X	X	X
530	AN503-416-10	. Screw, Machine (Flh), 1/4-20 X 0.625" (No Auxiliary Cooler)	8			X	X			
540	NAS1149F0432P	. Washer: Flat, 1/4" (0.032") Light	8			X	X	X	X	X
540	AN960-416L	. Washer (Superseded by NAS1149F0432P)	8			X	X	X	X	X
550	NAS43HT4-64	. Spacer	2			X	X	X	X	X
560	MS21919WCJ12	. Clamp, Loop, 3/4" Cushioned	3			X	X	X	X	X
565	AN526-1032R8	. Screw	1			X	X	X	X	X
570	MS35206-245	. Screw: Mach (Ph), 8-32 X 0.500"	9			X	X	X	X	X
570	AN515-8R8	. Screw (Superseded by MS35206-245)	9			X	X	X	X	X
575	NAS1149F0332P	. Washer	1			X	X	X	X	X
580	NAS1149FN816P	. Washer: Flat, #8" (0.016") Light	16			X	X	X	X	X
580	AN960-8L	. Washer (Superseded by NAS1149FN816P)	16			X	X	X	X	X
585	AN935-10	. Lock Washer	1			X	X	X	X	X
590	MS35338-42	. Washer: Lock, 0.040" #8 Light	7			X	X	X	X	X
590	AN935-8	. Lock Washer (Superseded by MS35338-42)	7			X	X	X	X	X
595	AN345-10	. Nut	1			X	X	X	X	X
600	MS35649-282	. Nut: Hex, 8-32 Unc-2b Light	7			X	X	X	X	X
600	AN340-8	. Nut (Superseded by MS35649-282)	7			X	X	X	X	X

ENSTROM F-28/280 SERIES ILLUSTRATED PARTS CATALOG

FIGURE 3-20 B. ENGINE FAN SHROUD ASSEMBLY

Early Models

ITEM NUMBER	PART NUMBER	DESCRIPTION	QTY PER ASSY	MODELS AFFECTED						
				F-28A	280	F-28C	280C	F-28F	280F	280FX
610	280-126001-69	. Bracket, Clamp, Support	3			X	X	X	X	X
620	AN742-F6	. Clamp	1			X	X	X	X	X
630	4508-2	. Tape: Foam, 2" W (0.125" T) Black	82"			X	X	X	X	X

* Obtain from a Lycoming Distributor.

‡ Effectivity F28 S/N 766 - 775 and subsequent. Effectivity 280 S/N 2049 – 2057, and 2059 and subsequent. Retrofittable to F28F S/N 509 and 280FX S/N 2001.

NOTE 1 Parts listed are for 28-12676-1, 28-12676-3 and 28-12676 -5 assemblies unless otherwise noted.

ENSTROM F-28/280 SERIES ILLUSTRATED PARTS CATALOG

FIGURE 3-24. MAIN FUEL SYSTEM

ITEM NUMBER	PART NUMBER	DESCRIPTION	QTY PER ASSY	MODELS AFFECTED						
				F-28A	280	F-28C	280C	F-28F	280F	280FX
350**	AN816-4D	. Adapter (Right Side)	1	X	X	X	X			
350	AN822-4D	. Elbow	2	X	X	X	X	X	X	X
360	AN911-1D	. Nipple	2	X	X	X	X	X	X	X
360	AN911-4D	. Nipple (Superseded by AN911-1D)	2	X	X	X	X	X	X	X
370	28-12459-1	. Drain Line, Right	1	X	X	X	X	X	X	X
370**	28-12451-1	. Drain Line (Obsolete)	1	X	X	X	X			
380	AN834-4	. Tee	2	X	X	X	X	X	X	X
380	AN834-4D	. Tee (Alternate)	2	X	X	X	X	X	X	X
390	28-12441-3	. Fuel Tank RH Drain Line Assembly	1	X	X	X	X	X	X	X
-	MS35489-14	. Grommet	1	X	X	X	X	X	X	X
400**	28-12436-1	. Drain Line (Obsolete)	1	X	X	X	X			
400	28-12456-1	. Drain Line, Scupper Left	1	X	X	X	X	X	X	X
410**	28-12436-1	. Drain Line (Obsolete)	1	X	X	X	X			
410	28-12457-1	. Drain Line, Left	1	X	X	X	X	X	X	X
420	28-12437-3	. Fuel Tank LH Drain Line Assembly	1	X	X	X	X	X	X	X
-	MS35489-10	. Grommet	1	X	X	X	X	X	X	X
430	64-632-74	. Fuel Shutoff Cable	1	X	X	X	X	X	X	X
-◆	MS21919WDG3	. Clamp	4	X	X	X	X	X	X	X
-◆	MS21919WDG12	. Clamp	4	X	X	X	X	X	X	X
-◆	MS35206-245	. Screw	4	X	X	X	X	X	X	X
-◆	NAS1149FN816P	. Washer	8	X	X	X	X	X	X	X
-◆	MS35338-42	. Lock Washer	4	X	X	X	X	X	X	X
-◆	MS35649-282	. Nut	4	X	X	X	X	X	X	X
440	ECD093-11	. Stop Nut	1	X	X	X	X	X	X	X
450	1/8X8-32	. Set Screw	1	X	X	X	X	X	X	X
460	AN316-12R	. Nut	1	X	X	X	X	X	X	X
460	AN316-12	. Nut (Superseded by AN316-12R)	1	X	X	X	X	X	X	X

ENSTROM F-28/280 SERIES ILLUSTRATED PARTS CATALOG

FIGURE 3-24. MAIN FUEL SYSTEM

ITEM NUMBER	PART NUMBER	DESCRIPTION	QTY PER ASSY	MODELS AFFECTED						
				F-28A	280	F-28C	280C	F-28F	280F	280FX
470	28-12416-4	. Plate	1	X	X	X	X	X	X	X
480	28-12416-3	. Placard Fuel Shutoff	1	X	X	X	X	X	X	X
490	280-124001-1	. Fuel Shutoff Valve Assembly (See Fig. 3-26 for breakdown)	1	X	X	X	X	X	X	X
500†	28-12418-1	. Control Handle, Drain	1	X	X	X	X	X	X	X
510†	AN931-4-16	. Grommet	1	X	X	X	X	X	X	X
520†	28-12419-1	. Sleeve	1	X	X	X	X	X	X	X
530†	MS24665-153	. Cotter Pin	1	X	X	X	X	X	X	X
530†	AN381-2-12	. Cotter Pin (Superseded by MS24665-153)	1	X	X	X	X	X	X	X
540†	NAS1149F0332P	. Washer	1	X	X	X	X	X	X	X
540†	AN960-10L	. Washer (Superseded by NAS1149F0332P)	1	X	X	X	X	X	X	X
550†	62	. Cowling Lock Pin	1	X	X	X	X	X	X	X
560†	28-12420-15	. Placard, Fuel Sump Drain	1	X	X	X	X	X	X	X
570†	28-12420-13	. Placard, Open Fuel	1	X	X	X	X	X	X	X
580†	28-12420-11	. Placard, Closed Fuel	1	X	X	X	X	X	X	X
590	28-12450-11	. Placard Red (Obsolete)	2	X						
590	28-12450-13	. Placard White (Obsolete)	2	X						
600	28-12433-1	. Placard (Red), 20 Gallon	2	X	X	X	X	X	X	X
600	28-12433-2	. Placard (White), Fuel Cap	2	X	X	X	X	X	X	X
610‡	28-12424-1	. Placard, Sight Gauge	2	X	X	X	X	X	X	
620‡	28-12465-1	. Placard, Fuel Tank Capacity	2	X	X	X	X	X	X	
630	28-12478-11	. Stick: Fuel Quantity	1	X	X	X	X	X	X	X

* Used with the PlusNuts in the aft cowl ring.

** Used with valve P/N K-9000S-1A.

† Used on F-28F S/N 746 and prior and 280FX S/N 2012 and prior.

‡ Used with 20 gal. tanks. Sight window no longer manufactured after April 1984.

△ This location is for R.H. pilot command only; remove one piece of hardware.

◆ Secures fuel shutoff cable to pylon.

◆◆ Includes Item 340.

ENSTROM F-28/280 SERIES ILLUSTRATED PARTS CATALOG

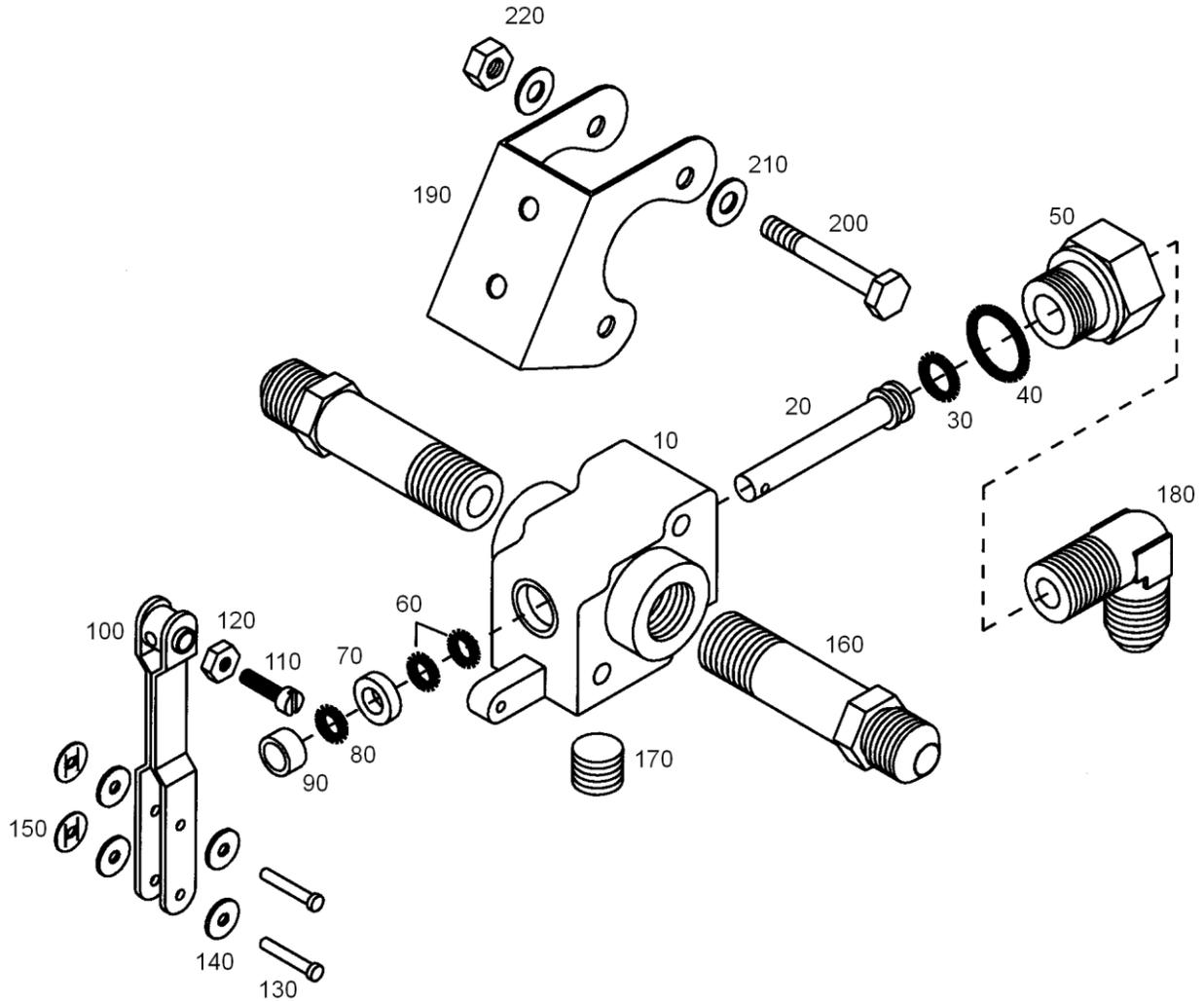

FIGURE 3-26. FUEL SHUTOFF VALVE ASSEMBLY

ENSTROM F-28/280 SERIES ILLUSTRATED PARTS CATALOG

FIGURE 3-26. FUEL SHUTOFF VALVE ASSEMBLY

ITEM NUMBER	PART NUMBER	DESCRIPTION	QTY PER ASSY	MODELS AFFECTED						
				F-28A	280	F-28C	280C	F-28F	280F	280FX
-	280-124001-1	. Fuel Shutoff Valve Assembly	1	X	X	X	X	X	X	X
-	4600-00	.. Fuel Shutoff Valve	1	X	X	X	X	X	X	X
10	4232	... Body Assembly	1	X	X	X	X	X	X	X
20	4234	... Valve Stem	1	X	X	X	X	X	X	X
30	M83248-2-010	... O-Ring	1	X	X	X	X	X	X	X
40	MS29513-113	... O-Ring	1	X	X	X	X	X	X	X
50	10005498	... Valve Seat	1	X	X	X	X	X	X	X
50	4235	... Valve Seat (Superseded by 10005498)	1	X	X	X	X	X	X	X
60	MS29513-010	... O-Ring	2	X	X	X	X	X	X	X
70	4241	... Washer	1	X	X	X	X	X	X	X
80	MS28778-2	.. O-Ring	1	X	X	X	X	X	X	X
80	2-010	.. O-Ring (Equivalent to MS28778-2)	1	X	X	X	X	X	X	X
80	NAS1611-010	.. O-Ring (Superseded by 2-010)	1	X	X	X	X	X	X	X
90	4503	.. Spacer	1	X	X	X	X	X	X	X
100	4208-00	.. Arm Assembly	1	X	X	X	X	X	X	X
110	MS35206-230	... Screw	1	X	X	X	X	X	X	X
110	AN515-6R8	... Screw (Superseded by MS35206-230)	1	X	X	X	X	X	X	X
110	AN500-6-8	... Screw	1	X	X	X	X	X	X	X
120	MS35649-262	... Nut	1	X	X	X	X	X	X	X
120	AN340-6	... Nut (Superseded by MS35649-262)	1	X	X	X	X	X	X	X
130*	MS20615-3M10	.. Rivet	2	X	X	X	X	X	X	X
130	18286-00	.. Rivet (Superseded by MS20615-3M10)	2	X	X	X	X	X	X	X
140	NAS1149FN316P	.. Washer	4	X	X	X	X	X	X	X
140	4222	.. Washer (Superseded by NAS1149FN316P)	4	X	X	X	X	X	X	X
150*	PS094032PG	.. Push Nut	2	X	X	X	X	X	X	X
150	18207	.. Nut, Tinnerman (Superseded by PS094032PG)	2	X	X	X	X	X	X	X

ENSTROM F-28/280 SERIES ILLUSTRATED PARTS CATALOG

FIGURE 3-26. FUEL SHUTOFF VALVE ASSEMBLY

ITEM NUMBER	PART NUMBER	DESCRIPTION	QTY PER ASSY	MODELS AFFECTED						
				F-28A	280	F-28C	280C	F-28F	280F	280FX
150	183204	. . Nut, Tinnerman (Superseded by 18207)	2	X	X	X	X	X	X	X
160	28-12417-11	. . Valve Adapter	2	X	X	X	X	X	X	X
160	28-12417-1	. . Valve Adapter (Superseded by 28-12417-11)	2	X	X	X	X	X	X	X
170	MS27769D3	. . Pipe Plug	1	X	X	X	X	X	X	X
170	AN932-D3	. . Plug (Replaced by MS27769D3)	1	X	X	X	X	X	X	X
180	MS20822-6D	. . Elbow	1	X	X	X	X	X	X	X
180	AN822-6D	. . Elbow (Superseded by MS20822-6D)	1	X	X	X	X	X	X	X
190	280-124001-3	. . Bracket Assembly	1	X	X	X	X	X	X	X
-	MS21059L3	. . . Nut Plate	2	X	X	X	X	X	X	X
-	NAJ1-02	. . . Nut Plate (Replaced by MS21059L3)	2	X	X	X	X	X	X	X
-	MS20426AD3-2	. . . Rivet	4	X	X	X	X	X	X	X
-	MS20426AD3-3	. . . Rivet (Replaced by MS20426AD3-2)	4	X	X	X	X	X	X	X
200	NAS6603-16	. . Bolt	2	X	X	X	X	X	X	X
200	AN3-13A	. . Bolt (Superseded by NAS6603-16)	2	X	X	X	X	X	X	X
210	NAS1149D0316H	. . Washer	4	X	X	X	X	X	X	X
210	AN960D10L	. . Washer (Superseded by NAS1149D0316H)	4	X	X	X	X	X	X	X
220	MS21083N3	. . Nut	2	X	X	X	X	X	X	X
220	AN364-1032A	. . Nut (Superseded by MS21083N3)	2	X	X	X	X	X	X	X
-	MS20995-C32	. Wire: Safety	A/R	X	X	X	X	X	X	X

* 18286 pin with 18207 Tinnerman push nut is an acceptable alternate.

ENSTROM F-28/280 SERIES ILLUSTRATED PARTS CATALOG

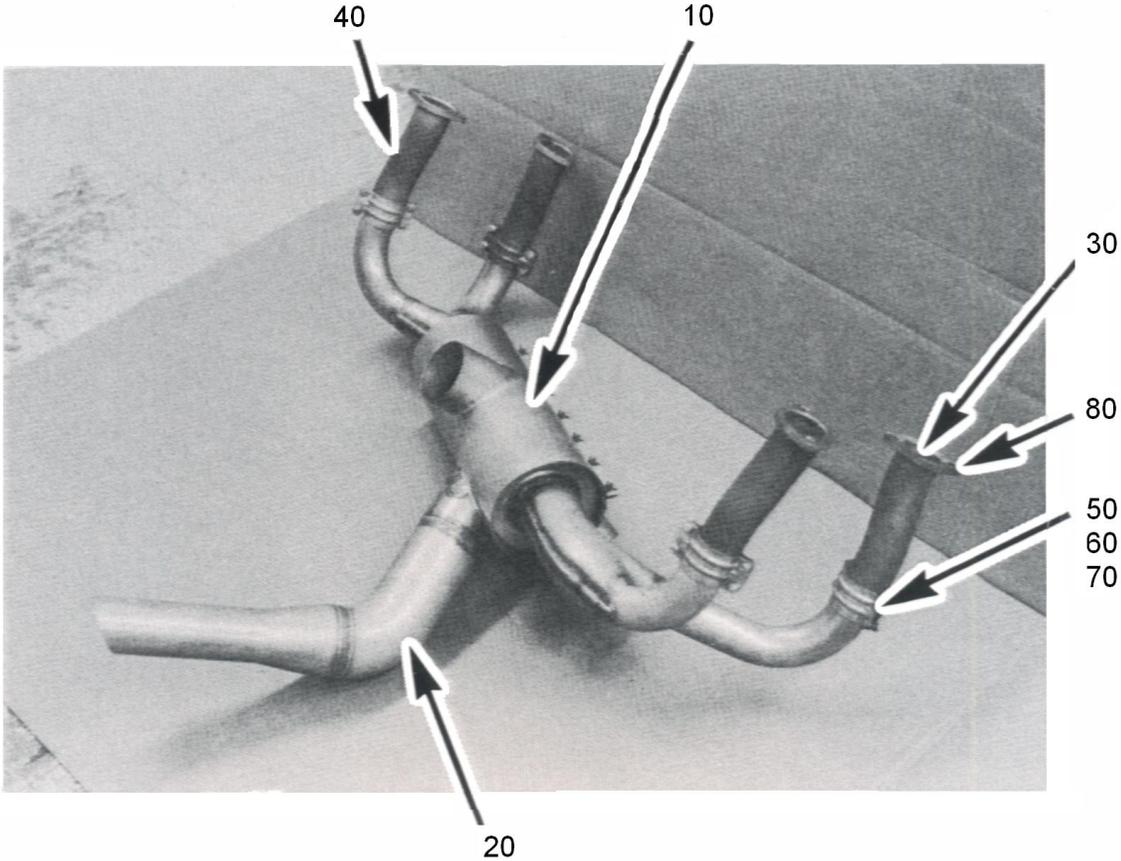

FIGURE 3-27. EXHAUST SYSTEM INSTALLATION (A MODELS)

ENSTROM F-28/280 SERIES ILLUSTRATED PARTS CATALOG

FIGURE 3-28. EXHAUST SYSTEM INSTALLATION (C, F MODELS)

ITEM NUMBER	PART NUMBER	DESCRIPTION	QTY PER ASSY	MODELS AFFECTED						
				F-28A	280	F-28C	280C	F-28F	280F	280FX
-	037360-004	. Exhaust System	1			X	X	X	X	X
10	EL-037360-107	. . Exhaust Riser, #2	1			X	X	X	X	X
20	EL-037360-202	. . Exhaust Riser, #4	1			X	X	X	X	X
30	EL-099005-401	. . Clamp Half	2			X	X	X	X	X
30	EL-037360-401	. . Clamp Half (Superseded by EL-099005-401)	2			X	X	X	X	X
40	AN3C4A	. . Bolt	4			X	X	X	X	X
50	MS21042-3	. . Nut	4			X	X	X	X	X
50	AN365-1032C	. . Nut (Superseded by MS21042-3)	4			X	X	X	X	X
60	EL-037360-113	. . Shroud Assembly	1			X	X	X	X	X
-	C-6352-10Z	. . . Tinnerman Nut	6			X	X	X	X	X
-	MS51861-35	. . . Screw	6			X	X	X	X	X
-	AN530C10-8	. . . Screw	6			X	X	X	X	X
-	037360-124	. . Collector Assembly	1					X	X	X
70	EL-037360-110	. . . Collector, Left Side	1			X	X			
70	EL-037360-111	. . . Collector, Left Side	1					X	X	X
80	EL-037360-206	. . . Exhaust Riser, #1	1			X	X	X	X	X
90	EL-099005-401	. . . Clamp Half	2			X	X	X	X	X
90	EL-037360-401	. . . Clamp Half (Superseded by EL-099005-401)	2			X	X			
100	AN3C4A	. . Bolt	4			X	X			
100	AN3C4A	. . Bolt	4					X	X	X
110	MS21042-3	. . Nut	4			X	X			
110	AN365-1032C	. . Nut (Superseded by MS21042-3)	4			X	X			
110	MS21042-3	. . Nut	4					X	X	X
110	AN365-1032C	. . Nut (Superseded by MS21042-3)	4					X	X	X
120	EL-037360-112	. . Turbo Inlet	1			X	X			
120	EL-037360-112	. . Turbo Inlet	1					X	X	X
130	EL-037360-116	. . Tail Pipe Assembly	1			X	X			

ENSTROM F-28/280 SERIES ILLUSTRATED PARTS CATALOG

FIGURE 3-28. EXHAUST SYSTEM INSTALLATION (C, F MODELS)

ITEM NUMBER	PART NUMBER	DESCRIPTION	QTY PER ASSY	MODELS AFFECTED						
				F-28A	280	F-28C	280C	F-28F	280F	280FX
130	EL-037360-123	. Tail Pipe Assembly	1					X	X	X
130	28-12577-1	. Muffler Assembly (Optional)	1					X	X	X
130	ENX-0001	. Muffler Assembly (Optional) Superseded by 28-12577-1	1					X	X	X
140*	77611	. Gasket Exhaust Flange	4			X	X	X	X	X
141*	LW-16567	. Gasket, Thin	A/R			X	X	X	X	X
150*	STD-35	. Washer	8			X	X	X	X	X
160/170*	STD-2233	. Lock Washer	8			X	X	X	X	X
160*	STD-475	. Lock Washer (#160 and #170 replaced by STD-2233 Locknut)	8			X	X	X	X	X
170*	STD-1410	. Nut (#160 and #170 replaced by STD-2233 Locknut)	8			X	X	X	X	X
180	28-125017-1	. Orifice Bypass Tube Assembly	1			X	X			
-	28-125000-11	. Tube, Bypass	1			X	X			
-	28-125016-11	. Orifice	1			X	X			
190	28-12552-3	. Waste Gate Assembly, With Alignment Pins	1					X	X	X
190	28-12552-5	. Waste Gate Assembly, Without Alignment Pins (Superseded by 28-12552-3)	1					X	X	X
200	QS100-M28	. Clamp (Used with 28-12552-5)	1					X	X	X
210	28-12574-11	. Pin (Used with 28-12552-3)	1					X	X	X
220	NAS428-3A10	. Bolt	2					X	X	X
220	AN502-10-14	. Screw (Superseded by NAS428- 3A10)	2					X	X	X
230	AN315-3R	. Nut	4					X	X	X
231A†	28-12554-103	. Linkage Assembly-Wastegate	1					X	X	X
240	28-12555-7	. Sleeve Assembly	1					X	X	X
250	K3N	. Plunger: Ball, 1/4-20 Stubby	1					X	X	X
260	28-12560-1	. Nut	1					X	X	X

ENSTROM F-28/280 SERIES ILLUSTRATED PARTS CATALOG

SECTION 7

STRUCTURES

TABLE OF CONTENTS

	Cover Page	7-1
	Table of Contents	7-1
7-1	Windows, Doors, and Compartment Enclosures (F-28A, F-28C, F-28F)	7-3
7-2	Window Installation (F-28A, F-28C, F-28F)	7-13
7-3	Sliding Window Vent Installation (F-28F)	7-15
7-4	Door Assembly and Installation (F-28F S/N 745 & Sub)	7-19
7-5	Windows, Doors, and Compartment Enclosure (280, 280C, 280F, 280FX)	7-27
7-6	280FX Cabin Doors Assembly/Installation	7-37
7-7	280FX Cabin Closeout Installation	7-43
7-8	Cowling (F-28A, F-28C)	7-45
7-9	Cowling (280, 280C)	7-49
7-10	Cowling (F-28F, 280FX)	7-53
7-11	Engine Compartment Enclosures	7-61
7-12	Three-Piece Airscoop (280FX)	7-65
7-13	Cabin Installation and Pylon and Tailcone Assembly	7-67
7-14	Tailcone Bulkhead and Skin Enclosures	7-71
7-15	Stabilizer and Tailcone Extension (F-28A, F-28C, F-28F)	7-75
7-16	Stabilizer and Tailcone Extension (280, 280C, 280F)	7-79
7-17	Stabilizer and Tailcone Extension (F-28F, 280FX)	7-83
7-18	Tail Rotor Drive Shaft Cover	7-87
7-19	Pylon Assembly to Landing Gear	7-91
7-20	Landing Gear Assembly	7-93
7-21	Oleo Strut Assembly	7-101
7-22	Landing Gear Fairings	7-105

ENSTROM F-28/280 SERIES ILLUSTRATED PARTS CATALOG

INTENTIONALLY LEFT BLANK

ENSTROM F-28/280 SERIES ILLUSTRATED PARTS CATALOG

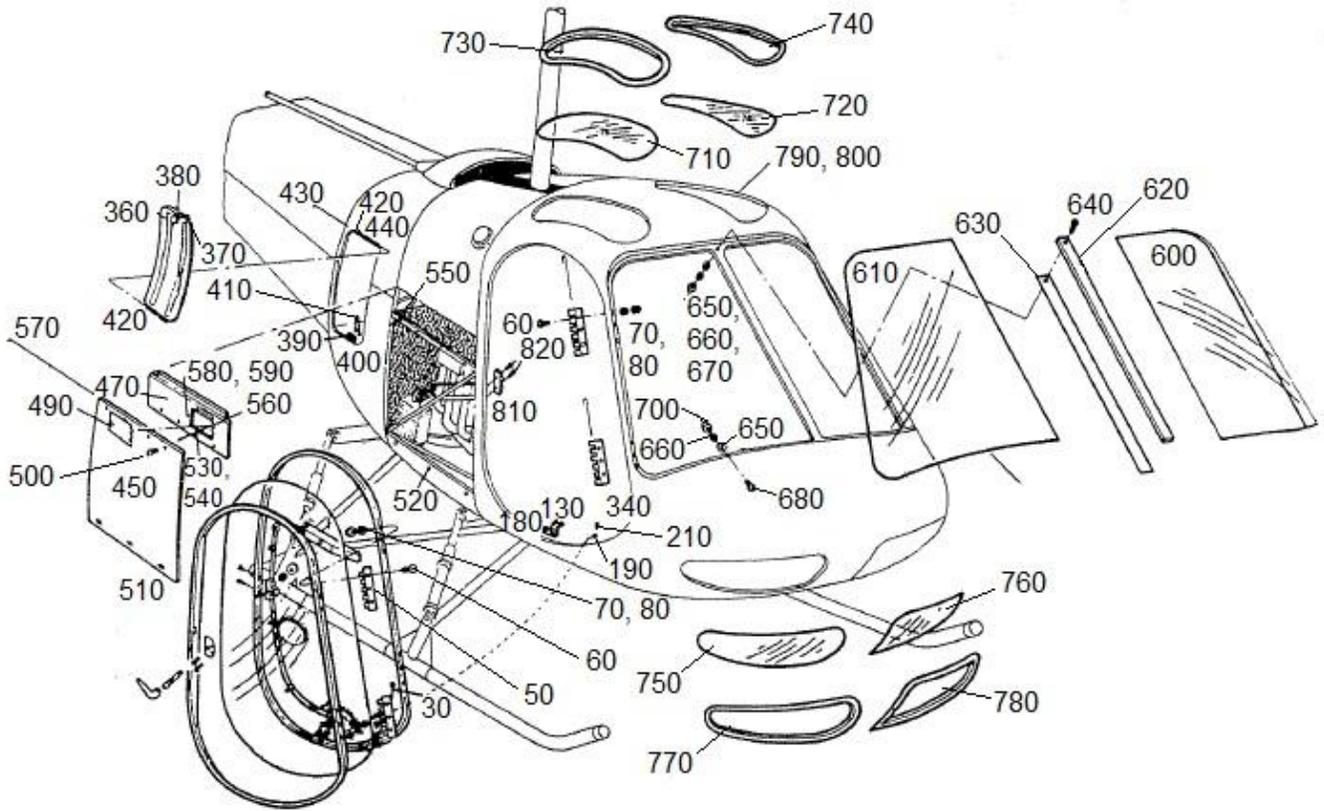

Sheet 1 of 3

FIGURE 7-1. WINDOWS, DOORS, AND COMPARTMENT ENCLOSURES (F-28A, F-28C, F-28F)

ENSTROM F-28/280 SERIES ILLUSTRATED PARTS CATALOG

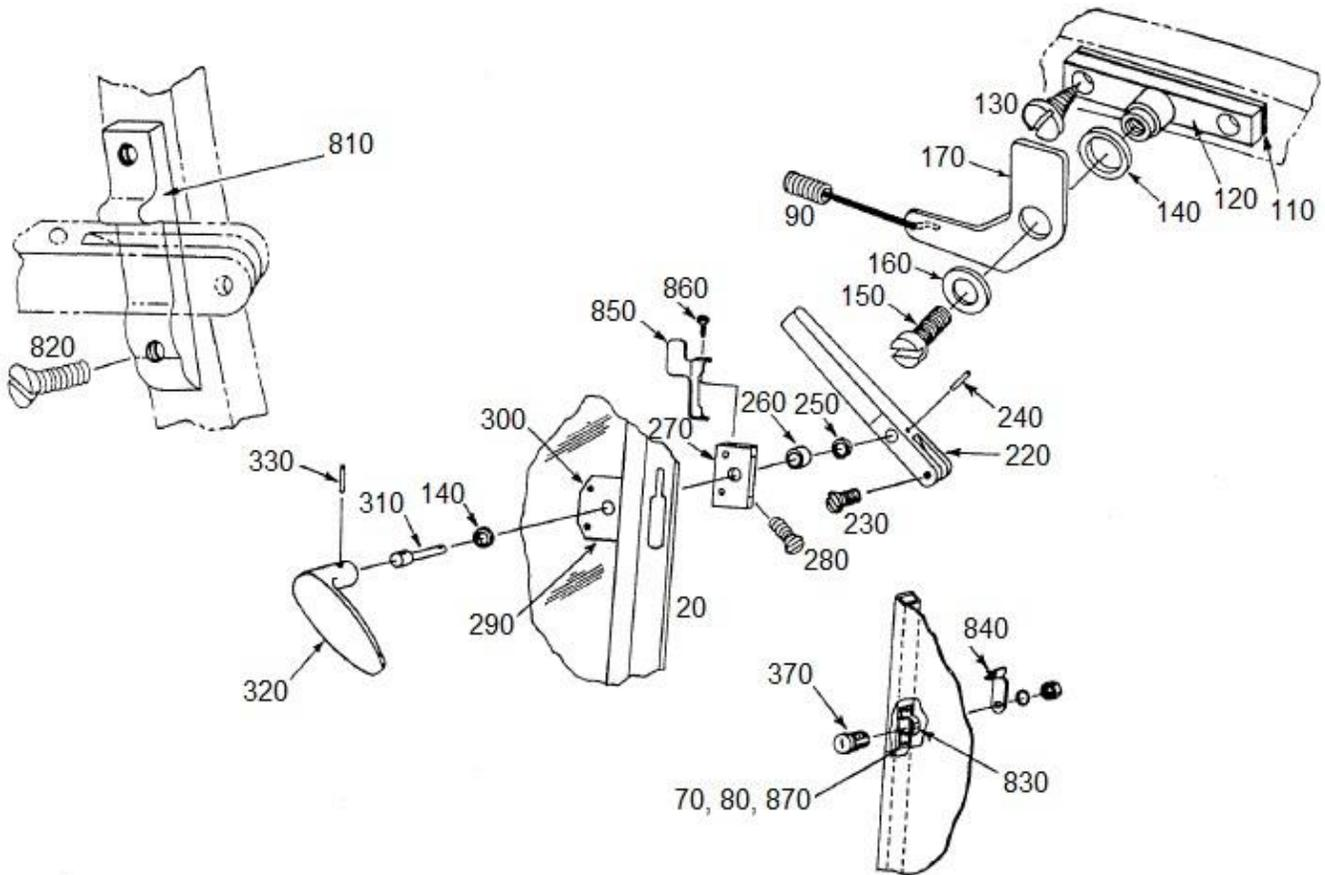

Sheet 2 of 3

FIGURE 7-1. WINDOWS, DOORS, AND COMPARTMENT ENCLOSURES (F-28A, F-28C, F-28F)

ENSTROM F-28/280 SERIES ILLUSTRATED PARTS CATALOG

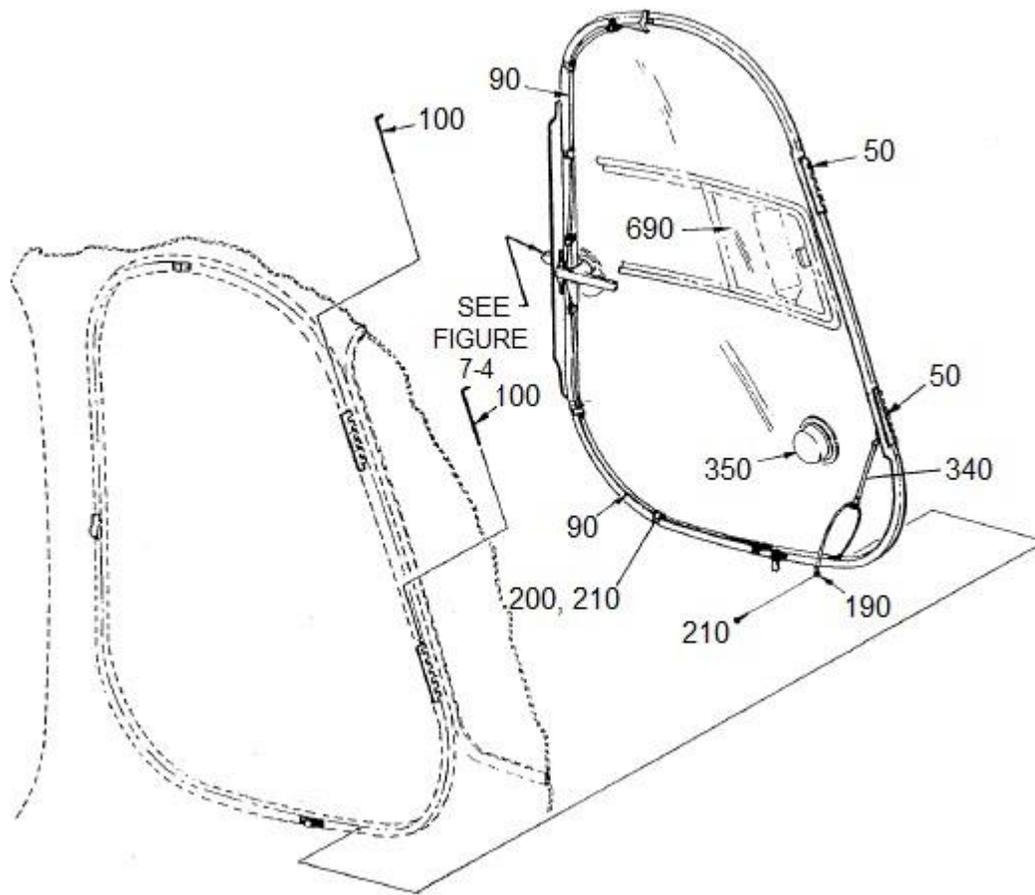

Sheet 3 of 3

FIGURE 7-1. WINDOWS, DOORS, AND COMPARTMENT ENCLOSURES (F-28A, F-28C, F-28F)

ENSTROM F-28/280 SERIES ILLUSTRATED PARTS CATALOG

FIGURE 7-1. WINDOWS, DOORS, AND COMPARTMENT ENCLOSURES (F-28A, F-28C, F-28F)

ITEM NUMBER	PART NUMBER	DESCRIPTION	QTY PER ASSY	MODELS AFFECTED						
				F-28A	280	F-28C	280C	F-28F	280F	280FX
-	28-11300	Cabin Installation	REF	X		X		X		
-10	28-11310-1	. Door Assembly, R/H	1	X		X		X		
20	28-11310-2	. Door Assembly, L/H	1	X		X		X		
30	28-11310-7	. Door Frame, R/H	1	X		X		X		
-40	28-11310-8	. Door Frame, L/H	1	X		X		X		
50	28-11310-11	. Door Hinge	2	X		X		X		
60	MS24694-S15	. Screw	12	X		X		X		
60	AN509-8R18	. Screw (Superseded by MS24694-S15)	12	X		X		X		
70	NAS1149FN816P	. Washer	12	X		X		X		
70	AN960-8L	. Washer (Alternate)	12	X		X		X		
80	MS20365-832	. Nut	12	X		X		X		
80	AN365-832	. Nut (Alternate)	12	X		X		X		
-	28-11418-1	. Door Latch Assembly, L/H	1	X		X		X		
-	28-11418-2	. Door Latch Assembly, R/H	1	X		X		X		
90	300-071-CS	. . Cable	2	X		X		X		
100	28-11310-905	. . Hinge Pin	4	X		X		X		
110	28-11436	. . Shims	A/R	X		X		X		
120	28-11417-1	. . Bracket	2	X		X		X		
-	AN530-8-7	. . Screw	4	X		X		X		
130	MS51862-13	. . Screw	4	X		X		X		
130	AN531-6R6	. . Screw (Superseded by MS51862-13)	4	X		X		X		
140	NAS1149C0563R	. . Washer	2	X		X		X		
140	AN960-C516	. . Washer (Alternate)	2	X		X		X		
150	NK500-8-10	. . Screw	2	X		X		X		
160	NAS1149FN832P	. . Washer	2	X		X		X		
160	AN960-8	. . Washer (Alternate)	2	X		X		X		
170	28-11412-3	. . Door Latch, L/H	1	X		X		X		
-175	28-11412-4	. . Door Latch, R/H	1	X		X		X		

ENSTROM F-28/280 SERIES ILLUSTRATED PARTS CATALOG

FIGURE 7-1. WINDOWS, DOORS, AND COMPARTMENT ENCLOSURES (F-28A, F-28C, F-28F)

ITEM NUMBER	PART NUMBER	DESCRIPTION	QTY PER ASSY	MODELS AFFECTED						
				F-28A	280	F-28C	280C	F-28F	280F	280FX
180	28-11435-1	.. Plate	2	X		X		X		
190	52305A15-6	.. Cable	1	X		X		X		
200	M21919-DG3	.. Clamp	8	X		X		X		
210	AN530-6-6	.. Screw	8	X		X		X		
220	28-11427-1	.. Latch Arm	1	X		X		X		
230	AN526-8-8	.. Screw	1	X		X		X		
240	79-028-125-0687	.. Roll Pin	1	X		X		X		
250	ECD050-11	.. Washer	1	X		X		X		
250	1/4 Harper	.. Washer (Alternate)	1	X		X		X		
260	28-11376-1	.. Spacer	2	X		X		X		
270	28-11373-1	.. Bracket	1	X		X		X		
-	AN507C-1032-12	.. Screw	2	X		X		X		
-	28-11371-1	.. Lock Plate	1	X		X		X		
280	AN507C-832-12	.. Screw	2	X		X		X		
290	28-11372-1	.. Latch Plate	1	X		X		X		
300	AN507C-632-8	.. Screw	2	X		X		X		
-	AN960-C416	.. Washer	1	X		X		X		
310	28-11428-1	.. Latch Rod	1	X		X		X		
320	AR134-D	.. Handle	1	X		X		X		
330	72-028-125-0500	.. Roll Pin	1	X		X		X		
340	28-11407-1	.. Bungee Cord	1	X		X		X		
350	CA-3251	.. Snap Vent	2	X		X		X		
360	28-11408-2	.. Baggage Door Assembly	1	X		X				
370	15753XC2L	.. Lock Assembly	1	X		X				
380	28-11437-1	.. Striker Arm	1	X		X				
390	28-11438-1	.. Catch Plate	1	X		X				
400	28-11408-10	.. Spacer	A/R	X		X				
410	MS27039-0807	.. Screw	2	X		X				
410	AN525-832R7	.. Screw (Superseded by MS27039-0807)	2	X		X				

ENSTROM F-28/280 SERIES ILLUSTRATED PARTS CATALOG

FIGURE 7-1. WINDOWS, DOORS, AND COMPARTMENT ENCLOSURES (F-28A, F-28C, F-28F)

ITEM NUMBER	PART NUMBER	DESCRIPTION	QTY PER ASSY	MODELS AFFECTED						
				F-28A	280	F-28C	280C	F-28F	280F	280FX
-	NAS1149FN816P	.. Washer	4	X		X				
-	AN960-8L	.. Washer (Alternate)	4	X		X				
-	MS20365-832	.. Nut	2	X		X				
-	AN365-832	.. Nut (Alternate)	2	X		X				
420	MS20257-P4	.. Hinge	1	X		X				
430	MS20253-2	.. Pin	1	X		X				
440	MS27039-0806	.. Screw	5	X		X				
440	AN525-832R6	.. Screw	5	X		X				
-	NAS1149FN816P	.. Washer	5	X		X				
-	AN960-8L	.. Washer (Alternate)	5	X		X				
-	MS20365-832	.. Nut	5	X		X				
-	AN365-832	.. Nut (Alternate)	5	X		X				
-	28-11400-1	. Cowl Installation	1	X		X				
-	28-11414-1	.. Left Side Cowl	1	X		X				
-	28-11414-2	.. Right Side Cowl	1	X		X				
450	28-11414-4	... Engine Cowl, R/H Lower	1	X		X				
-460	28-11414-3	... Engine Cowl, L/H Lower	1	X		X				
470	28-11414-6	... Engine Cowl, R/H Upper	1	X		X				
-480	28-11414-5	... Engine Cowl, L/H Upper	1	X		X				
490	28-11440-1	... Access Door	1	X		X				
500	AN507-632-5	... Screw	6	X		X				
-	MS35338-41	... Lock Washer	6	X		X				
-	AN935-6	... Lock Washer (Alternate)	6	X		X				
-	AN340-6	... Nut	6	X		X				
510	5-W-140	... Fastener	3	X		X				
-	85-46-101-39	... Washer	3	X		X				
-	85-34-101-17	... Retaining Ring	3	X		X				
520	5-295	... Receptacle	3	X		X				
530	AJ4-35	... DZUS Stud	5	X		X				

ENSTROM F-28/280 SERIES ILLUSTRATED PARTS CATALOG

FIGURE 7-1. WINDOWS, DOORS, AND COMPARTMENT ENCLOSURES (F-28A, F-28C, F-28F)

ITEM NUMBER	PART NUMBER	DESCRIPTION	QTY PER ASSY	MODELS AFFECTED						
				F-28A	280	F-28C	280C	F-28F	280F	280FX
540	GA4-250	. . . Grommet	6	X		X				
550	S4-200	. . Spring	6	X		X				
560	MS20257-4	. . . Hinge	1	X		X				
570	MS20253-2	. . . Hinge Pin	1	X		X				
580	82-12-120-16	. . Fastener	2	X		X				
-	43-13-1-24	. . Spring	2	X		X				
-	82-32-101-17	. . Ring Retainer	2	X		X				
-	82-46-101-39	. . Nylon Washer	2	X		X				
590	82-35-302-15	. . Retainer	2	X		X				
-	28-11300-1	. Cabin Installation	1	X		X				
-	28-11309-1	. . Windshield Assembly	1	X		X				
600	28-11309-3	. . . Windshield, L/H	1	X		X				
610	28-11309-4	. . . Windshield, R/H	1	X		X				
620	28-11309-6	. . . Retaining Strip	1	X		X				
630	28-11309-7	. . . Seal	1	X		X				
640	AN525-832-18	. . . Screw	A/R	X		X				
650	NAS1149FN816P	. . . Washer	A/R	X		X				
650	AN960-8L	. . . Washer (Alternate)	A/R	X		X				
660	MS35338-42	. . . Washer	A/R	X		X				
660	AN935-8L	. . . Lock Washer (Alternate)	A/R	X		X				
670	MS20365-832	. . . Nut	A/R	X		X				
670	AN365-832	. . . Nut (Alternate)	A/R	X		X				
680	MS24693-S51	. . . Screw	A/R	X		X				
680	AN507-832R9	. . . Screw (Superseded by MS24693-S51)	A/R	X		X				
690	28-11710-11	. . Sliding Window Assembly, L/H	1	X		X		X		
690	28-11710-1	. . Sliding Window Assembly, L/H (Replaced by 28-11710-11)	1	X		X		X		
-695	28-11710-12	. . Sliding Window Assembly, R/H	1	X		X		X		
-695	28-11710-2	. . Sliding Window Assembly, R/H (Replaced by 28-11710-12)	1	X		X		X		

ENSTROM F-28/280 SERIES ILLUSTRATED PARTS CATALOG

FIGURE 7-1. WINDOWS, DOORS, AND COMPARTMENT ENCLOSURES (F-28A, F-28C, F-28F)

ITEM NUMBER	PART NUMBER	DESCRIPTION	QTY PER ASSY	MODELS AFFECTED						
				F-28A	280	F-28C	280C	F-28F	280F	280FX
-	28-11708-1	.. Sliding Wing Window, L/H	1	X		X		X		
-	28-11708-2	.. Sliding Wing Window, R/H	1	X		X		X		
-	28-11709-1	.. Sliding Window Assembly, L/H	1	X		X		X		
-	28-11709-2	.. Sliding Window Assembly, R/H	1	X		X		X		
-	28-11711-17	.. Pivot Block, L/H	2	X		X		X		
-	28-11711-11	.. Pivot Block, L/H (Replaced by 28-11711-17)	2	X		X		X		
-	28-11711-18	.. Pivot Block, R/H	2	X		X		X		
-	28-11711-12	.. Pivot Block, R/H (Replaced by 28-11711-18)	2	X		X		X		
-	28-11712-11	.. Handle	1	X		X		X		
-	28-22165-1	.. Bushing	2	X		X		X		
-	AN526-C1032-9	.. Screw	2	X		X		X		
-	MS21083N3	.. Nut	4	X		X		X		
-	AN364-1032A	.. Nut (Superseded by MS21083N3)	4	X		X		X		
-	NAS1149C0332R	.. Washer	6	X		X		X		
-	AN960-C10L	.. Washer (Alternate)	6	X		X		X		
-	AN42B-14	.. Eye Bolt	2	X		X		X		
-	MS35206-230	.. Screw	3	X		X		X		
-	AN526-632R8	.. Screw (Superseded by MS35206-230)	3	X		X		X		
-	MS35206-227	.. Screw	4	X		X		X		
-	AN526-632-5	.. Screw (Superseded by MS35206-227)	4	X		X		X		
-	NAS1149FN616P	.. Washer	6	X		X		X		
-	AN960-6L	.. Washer (Alternate)	6	X		X		X		
-	MS21083N06	.. Nut	4	X		X		X		
-	AN364-632A	.. Nut (Superseded by MS21083N06)	4	X		X		X		
-	MS51861-25	.. Screw	2	X		X		X		
-	AN530-6-8	.. Screw (Superseded by MS51861-25)	2	X		X		X		

ENSTROM F-28/280 SERIES ILLUSTRATED PARTS CATALOG

FIGURE 7-1. WINDOWS, DOORS, AND COMPARTMENT ENCLOSURES (F-28A, F-28C, F-28F)

ITEM NUMBER	PART NUMBER	DESCRIPTION	QTY PER ASSY	MODELS AFFECTED						
				F-28A	280	F-28C	280C	F-28F	280F	280FX
-	28-113071-1	. . Sliding Window Vent Fastener Installation	1	X		X				
700	MS35649-282	. . Nut	A/R	X		X				
700	AN340-832	. . Nut (Superseded by MS35649-282)	A/R	X		X				
-	28-113048-2	Cabin Assembly, Dual Control	REF	X		X		X		
-*	28-11425-2	. . Overhead and Lower Deck Window Installation	1	X		X		X		
710	28-11425-4	. . Overhead Glass, R/H	1	X		X		X		
720	28-11425-3	. . Overhead Glass, L/H	1	X		X		X		
730▲	28-11425-8	. . Overhead Extrusion, R/H	1	X		X				
740▲	28-11425-7	. . Overhead Extrusion, L/H	1	X		X				
750	28-11425-6	. . Lower Glass, R/H	1	X		X		X		
760	28-11425-5	. . Lower Glass, L/H	1	X		X		X		
770▲	28-11425-10	. . Lower Extrusion, R/H	1	X		X				
780▲	28-11425-9	. . Lower Extrusion, L/H	1	X		X				
790	CR-163-4-6	. . Rivet	A/R	X		X				
800	AN960-4	. Washer	A/R	X		X				
810	28-11371-1	. Latch	2	X		X		X		
820	MS24693-C274	. Screw	4	X		X		X		
820	AN507C1032-12	. Screw (Superseded by MS24693-C274)	4	X		X		X		
-	28-11700	Door Lock Assembly	REF	X		X		X		
830	28-11701-1	. Door Lock Bracket	1	X		X		X		
840	28-11702-1	. Latch Arm, L/H	1	X		X		X		
-845	28-11702-2	. Latch Arm, R/H	1	X		X		X		
850	28-11703-1	. Lock Bracket, L/H	1	X		X		X		
-855	28-11703-2	. Lock Bracket, R/H	1	X		X		X		
860	NK500-8-5	. Screw	4	X		X		X		
870	AN509-8R12	. Screw	2	X		X		X		
-	NAS1149FN816P	. Washer	2	X		X		X		

ENSTROM F-28/280 SERIES ILLUSTRATED PARTS CATALOG

FIGURE 7-1. WINDOWS, DOORS, AND COMPARTMENT ENCLOSURES (F-28A, F-28C, F-28F)

ITEM NUMBER	PART NUMBER	DESCRIPTION	QTY PER ASSY	MODELS AFFECTED						
				F-28A	280	F-28C	280C	F-28F	280F	280FX
-	AN960-8L	. Washer (Alternate)	2	X		X		X		

* Use Silastic 732 RTV or equivalent, as required, to seal overhead and lower deck windows to extrusions and to seal extrusions to cabin shell.

▲ Used on early models only.

ENSTROM F-28/280 SERIES ILLUSTRATED PARTS CATALOG

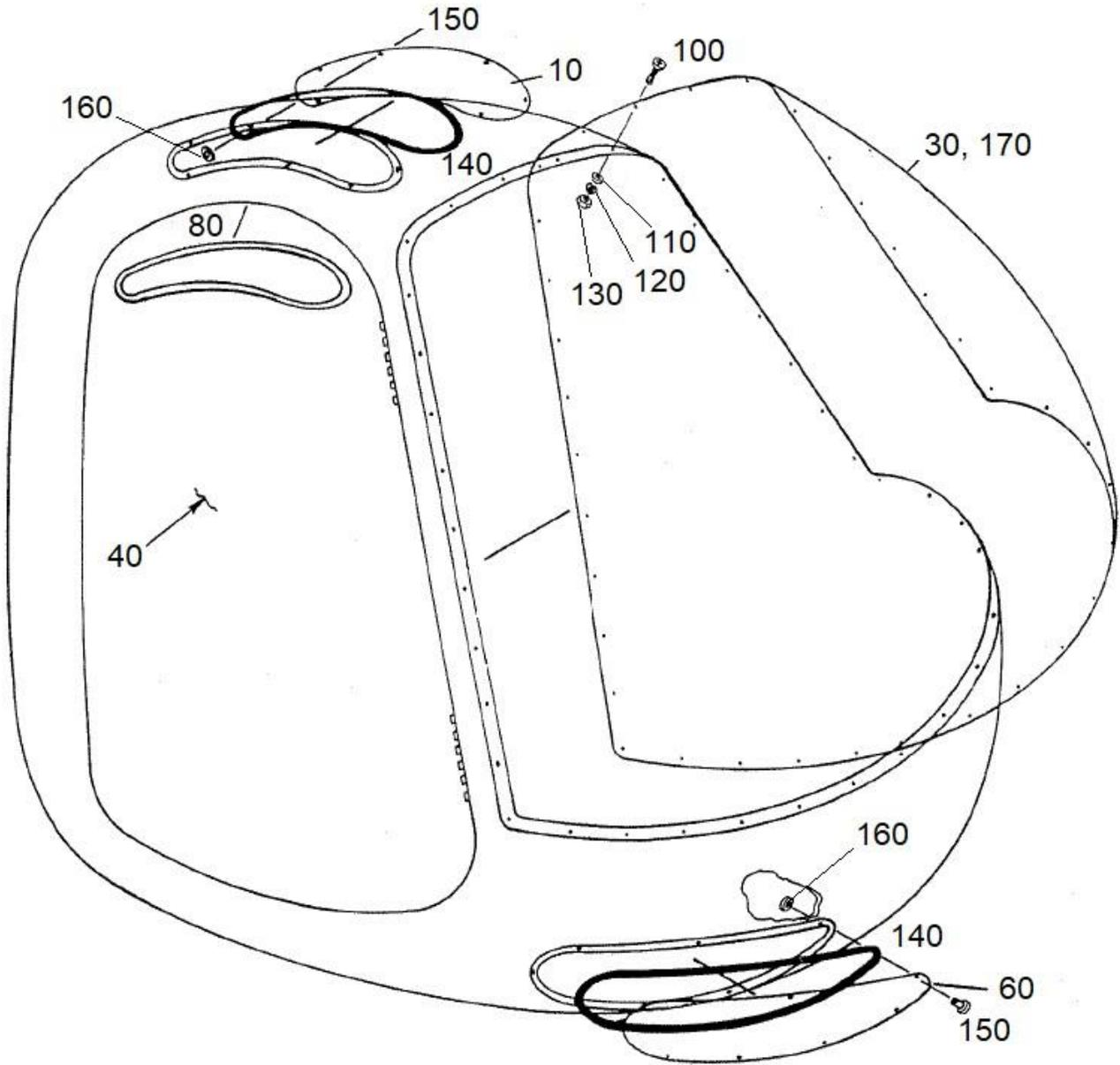

FIGURE 7-2. WINDOW INSTALLATION (F-28A, F-28C, F-28F)

ENSTROM F-28/280 SERIES ILLUSTRATED PARTS CATALOG

FIGURE 7-2. WINDOW INSTALLATION (F-28A, F-28C, F-28F)

ITEM NUMBER	PART NUMBER	DESCRIPTION	QTY PER ASSY	MODELS AFFECTED						
				F-28A	280	F-28C	280C	F-28F	280F	280FX
-	28-113048-2	Cabin Assembly, Dual Control	REF	X		X		X		
-	28-11425-2	. Overhead & Lower Deck Window Installation	1	X		X		X		
10	28-11425-3	. . Overhead Glass, L/H	1	X		X		X		
-20	28-11425-4	. . Overhead Glass, R/H	1	X		X		X		
30	28-113052-2	. Windshield (F-28C2)	1			X		X		
40	28-11310-103	. Door Assembly, R/H	1	X		X		X		
-50	28-11310-104	. Door Assembly, L/H	1	X		X		X		
60	28-11425-6	. . Lower Glass, R/H	1	X		X		X		
-70	28-11425-5	. . Lower Glass, L/H	1	X		X		X		
80	28-11607-12	. Trim Cap, R/H	1			X		X		
-90	28-11607-11	. Trim Cap, L/H	1			X		X		
100	MS24693-S49	. Screw	36			X		X		
100	AN507-832R7	. Screw (Superseded by MS24693-S49)	36			X		X		
110	NAS1149FN816P	. Washer	36			X		X		
110	AN960-8L	. Washer (Alternate)	36			X		X		
120	MS35338-42	. Lock Washer	36			X		X		
120	AN935-8L	. Lock Washer (Alternate)	36			X		X		
130	MS35649-282	. Nut	36			X		X		
130	AN340-832	. Nut (Superseded by MS35649-832)	36			X		X		
140	#4016	. . Foam Tape	A/R			X		X		
150	CR91484-4-4	. . Rivet	30			X		X		
160	NAS1149FN416P	. Washer	A/R			X		X		
160	AN960-4L	. Washer (Alternate)	A/R			X		X		
170	28-11309-3	. Windshield, L/H	1	X		X				
-180	28-11309-4	. Windshield, R/H	1	X		X				

ENSTROM F-28/280 SERIES ILLUSTRATED PARTS CATALOG

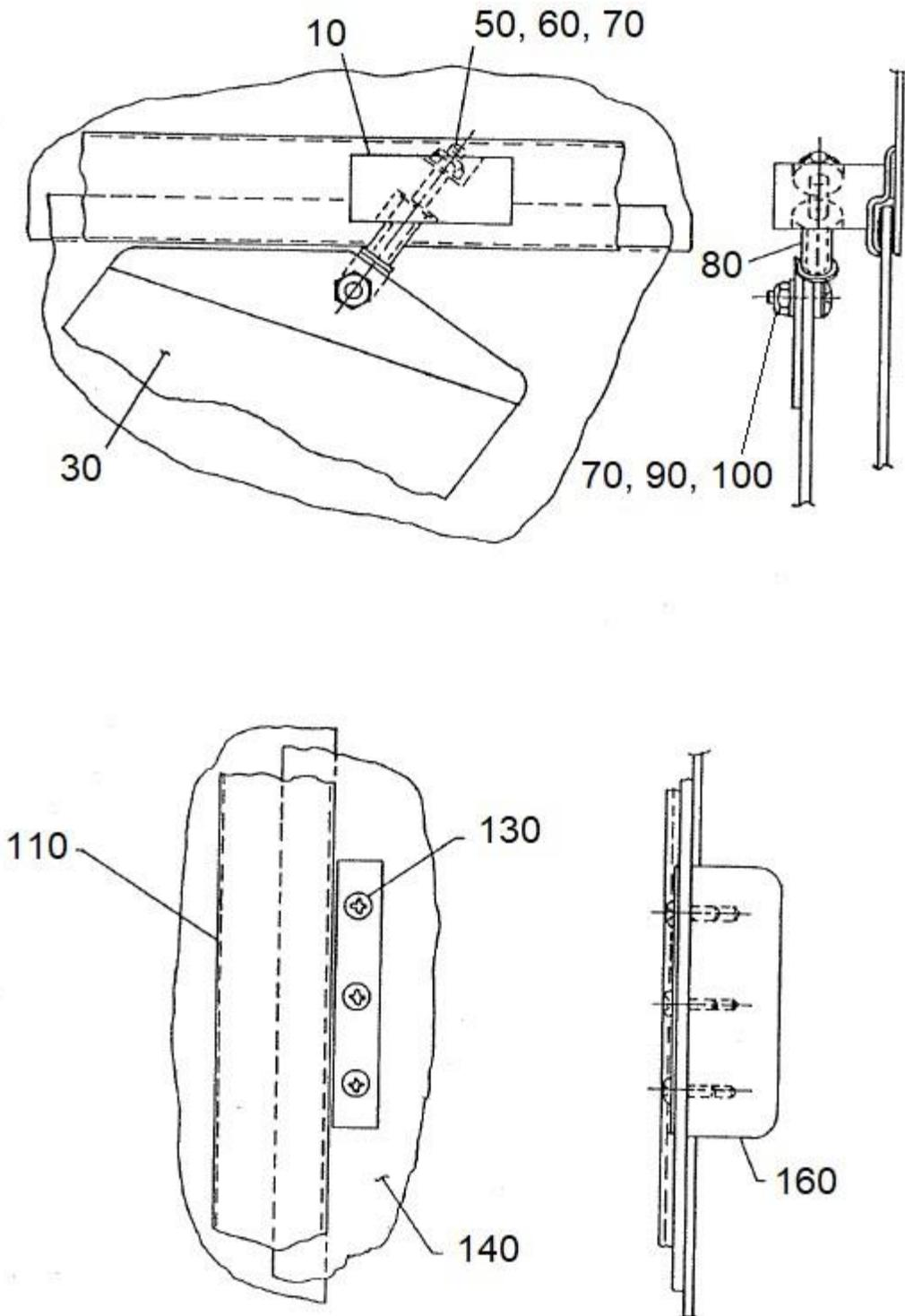

FIGURE 7-3. SLIDING WINDOW VENT INSTALLATION (F-28F)

ENSTROM F-28/280 SERIES ILLUSTRATED PARTS CATALOG

FIGURE 7-3. SLIDING WINDOW VENT INSTALLATION (F-28F)

ITEM NUMBER	PART NUMBER	DESCRIPTION	QTY PER ASSY	MODELS AFFECTED						
				F-28A	280	F-28C	280C	F-28F	280F	280FX
-	28-11714-3	Sliding Window Vent Installation, L/H	1					X		
-	28-11714-4	Sliding Window Vent Installation, R/H	1					X		
10	28-11711-17	. Pivot Block, L/H	1					X		
10	28-11711-11	. Pivot Block, L/H (Superseded by 28-11711-17)	1					X		
-20	28-11711-18	. Pivot Block, R/H	1					X		
-20	28-11711-12	. Pivot Block, R/H (Superseded by 28-11711-18)	1					X		
30	28-11708-1	. Wing Window, L/H	1					X		
-40	28-11708-2	. Wing Window, R/H	1					X		
50	AN42B-C12A	. Eye Bolt	2					X		
50	AN42B-C14A	. Eye Bolt (Alternate)	2					X		
50	AN42B-C11A	. Eye Bolt (Superseded by AN42B-C12A)	2					X		
60	NAS1149F0332P	. Washer	2					X		
60	AN960-10L	. Washer (Alternate)	2					X		
70	MS21083N3	. Nut	6					X		
70	AN364-1032A	. Nut (Superseded by MS21083N3)	6					X		
80	28-22165-1	. Bushing	2					X		
90	AN526C1032-9	. Screw	2					X		
100	NAS1149F0363P	. Washer	3					X		
100	AN960-10	. Washer (Alternate)	3					X		
110	28-11710-11	. Sliding Window Track, L/H	1					X		
110	28-11710-1	. Sliding Window Track, L/H (Superseded by 28-11710-11)	1					X		
-120	28-11710-12	. Sliding Window Track, R/H	1					X		
-120	28-11710-2	. Sliding Window Track, R/H (Superseded by 28-11710-12)	1					X		
130	AN526-6R8	. Screw	7					X		
140	28-11709-3	. Sliding Window, L/H	1					X		

ENSTROM F-28/280 SERIES ILLUSTRATED PARTS CATALOG

FIGURE 7-3. SLIDING WINDOW VENT INSTALLATION (F-28F)

ITEM NUMBER	PART NUMBER	DESCRIPTION	QTY PER ASSY	MODELS AFFECTED						
				F-28A	280	F-28C	280C	F-28F	280F	280FX
-150	28-11709-4	. Sliding Window, R/H	1					X		
160	28-11712-15	. Handle	1					X		
160	28-11712-11	. Handle (Superseded by 28-11712-15)	1					X		

ENSTROM F-28/280 SERIES ILLUSTRATED PARTS CATALOG

I

INTENTIONALLY LEFT BLANK

ENSTROM F-28/280 SERIES ILLUSTRATED PARTS CATALOG

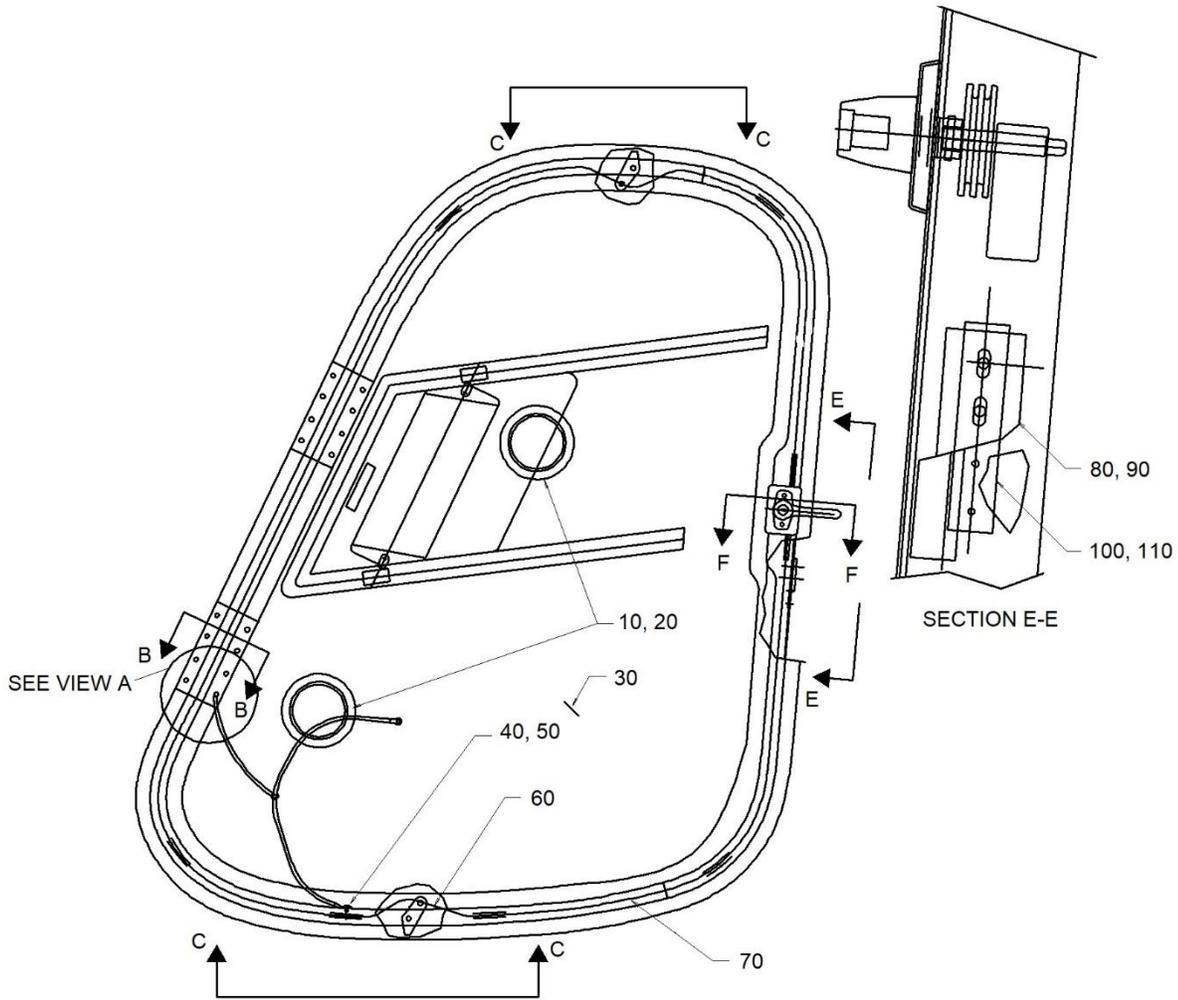

Sheet 1 of 3

FIGURE 7-4. DOOR ASSEMBLY AND INSTALLATION (F-28F S/N 745 & SUB)

ENSTROM F-28/280 SERIES ILLUSTRATED PARTS CATALOG

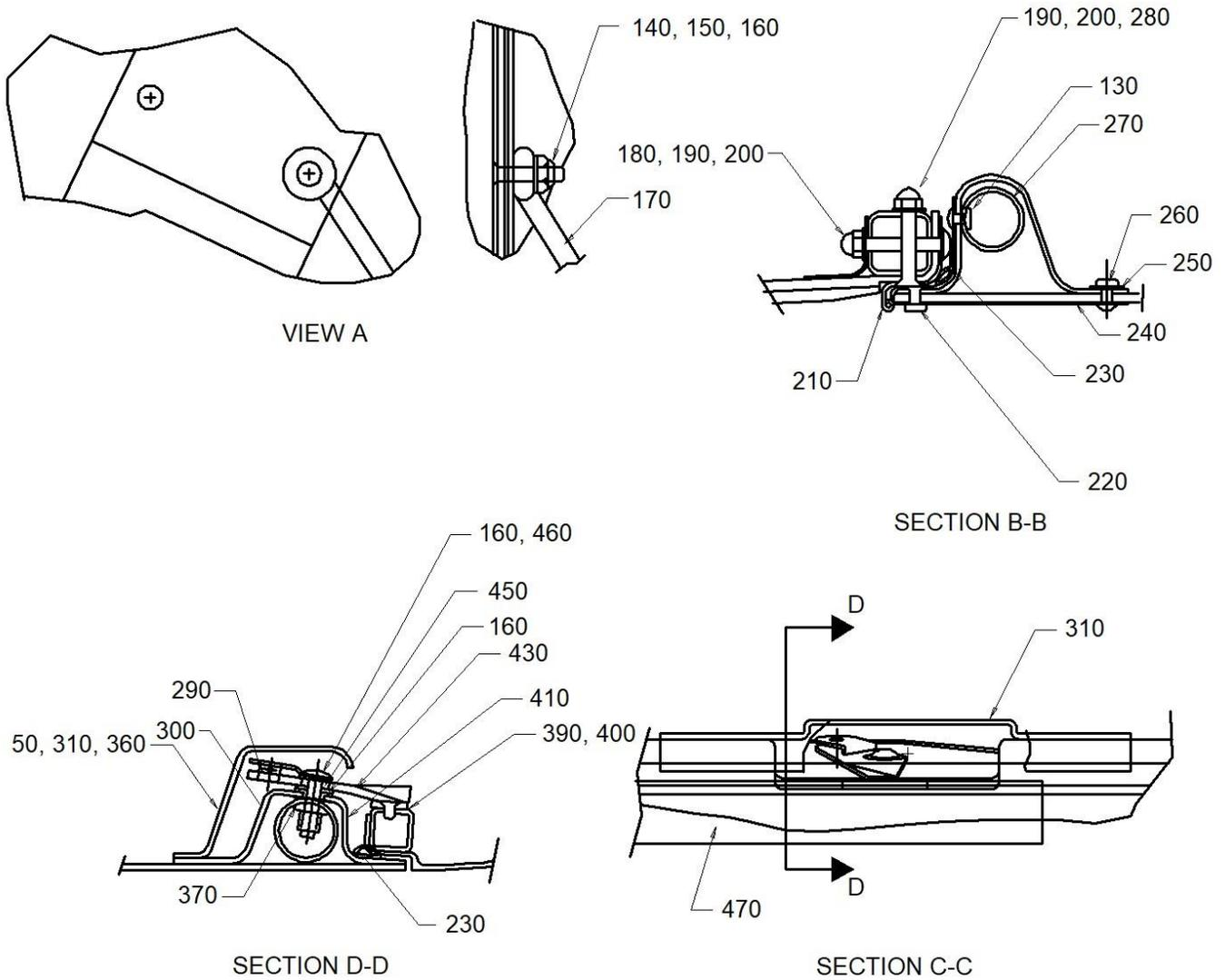

Sheet 2 of 3

FIGURE 7-4. DOOR ASSEMBLY AND INSTALLATION (F-28F S/N 745 & SUB)

ENSTROM F-28/280 SERIES ILLUSTRATED PARTS CATALOG

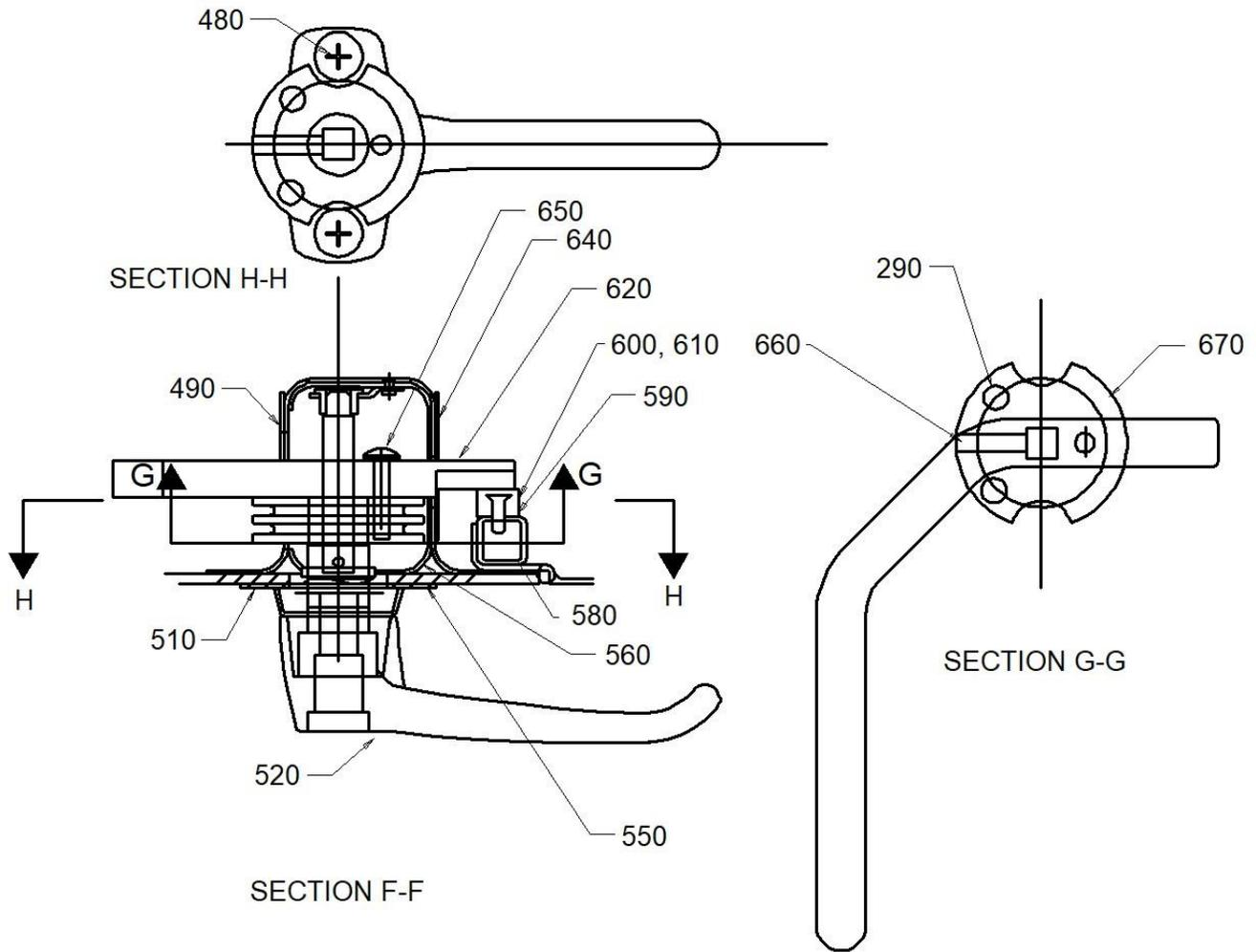

Sheet 3 of 3

FIGURE 7-4. DOOR ASSEMBLY AND INSTALLATION (F-28F S/N 745 & SUB)

ENSTROM F-28/280 SERIES ILLUSTRATED PARTS CATALOG

FIGURE 7-4. DOOR ASSEMBLY AND INSTALLATION (F-28F S/N 745 & SUB)

ITEM NUMBER	PART NUMBER	DESCRIPTION	QTY PER ASSY	MODELS AFFECTED						
				F-28A	280	F-28C	280C	F-28F	280F	280FX
-▲	28-113090-23	Door Assembly and Installation, L/H	REF					X		
-▲	28-113090-3	Door Assembly and Installation, L/H (Superseded by 28-113090-23)	REF					X		
-▲	28-113090-24	Door Assembly and Installation, R/H	REF					X		
-▲	28-113090-4	Door Assembly and Installation, R/H (Superseded by 28-113090-24)	REF					X		
10	CC-3251	. Snap Vent	2					X		
20*	28-11715-11	. Ring	2					X		
20	28-11310-10	. Ring (Replaced by 28-11715-11)	2					X		
30	28-113090-21	. Door Plexiglass, L/H	1					X		
30	28-11310-6	. Door Plexiglass L/H (Replaced by 28-113090-21)	1					X		
-40	28-113090-22	. Plexiglass, R/H	1					X		
-40	28-11310-5	. Door Plexiglass, R/H (Replaced by 28-113090-22)	1					X		
50	S6P-270	. Plus Nut	2					X		
60	AN526-8R12	. Screw	2					X		
70	3498T613	. Cable	A/R					X		
70	300-071	. Cable (Superseded by 3498T613)	A/R					X		
70	3A-3308	. Cable (Superseded by 300-071)	A/R					X		
80	300-072	. Casing	A/R					X		
90	28-11713-11	. Plate. L/H	1					X		
-100	28-11713-12	. Plate, R/H	1					X		
110	AN507-8R9	. Screw	2					X		
120	28-11713-15	. Plate	1					X		
130	CR3213-4-2	. Rivet	8					X		
140	MS24694-S7	. Screw	1					X		
140	AN509-8R10	. Screw (Superseded by MS24694-S7)	1					X		
150	MS20365-832	. Nut	1					X		

ENSTROM F-28/280 SERIES ILLUSTRATED PARTS CATALOG

FIGURE 7-4. DOOR ASSEMBLY AND INSTALLATION (F-28F S/N 745 & SUB)

ITEM NUMBER	PART NUMBER	DESCRIPTION	QTY PER ASSY	MODELS AFFECTED						
				F-28A	280	F-28C	280C	F-28F	280F	280FX
150	AN365-832	. Nut (Alternate)	1					X		
160	NAS1149F0363P	. Washer	2					X		
160	AN960-10	. Washer (Alternate)	2					X		
170	28-11407-5	. Bungee Cord	1					X		
180	AN525-8R16	. Screw	2					X		
190	NAS1149FN816P	. Washer	6					X		
190	AN960-8L	. Washer (Alternate)	6					X		
200	22NKM-82	. Acorn Nut	6					X		
210	28-113076-1	. Hinge	2					X		
-	MS20253-P2-7200	. Hinge Pin	2					X		
-	28-113076-15	. Hinge Pin (Superseded by MS20253-P2-7200)	2					X		
220	CR3212-4-4	. Rivet	8					X		
230	X1333HT	. Seal	10'					X		
230	ZX-10204	. Seal (Replaced by X1333HT)	10'					X		
240	28-113078-11	. Doubler, Door	2					X		
250	28-113087-11	. Hinge Plate Doubler	2					X		
260	CR3213-4-4	. Rivet	7					X		
270	28-113090-25	. Stiffener	1					X		
270	28-113077-11	. Doubler, Door (Replaced by 28-113090-25)	1					X		
280	MS24694-S13	. Screw	4					X		
280	AN509-8R16	. Screw (Superseded by MS24694-S13)	4					X		
290	1053	. Stop Nut	3					X		
300	28-113088-11	. Door Latch Doubler	2					X		
310	28-113090-11	. Door Cable Cover, Top, L/H	1					X		
-320	28-113090-12	. Door Cable Cover, Top R/H	1					X		
-340	28-113090-13	. Door Cable Cover, Bottom, L/H	1					X		
-350	28-113090-14	. Door Cable Cover, Bottom, R/H	1					X		
360	AN526-6R8	. Screw	7					X		

ENSTROM F-28/280 SERIES ILLUSTRATED PARTS CATALOG

FIGURE 7-4. DOOR ASSEMBLY AND INSTALLATION (F-28F S/N 745 & SUB)

ITEM NUMBER	PART NUMBER	DESCRIPTION	QTY PER ASSY	MODELS AFFECTED						
				F-28A	280	F-28C	280C	F-28F	280F	280FX
370	S10P-175	. Plus Nut	2					X		
380	28-11484-13	. Door Strike	4					X		
390	28-11435-1	. Lock Plate	2					X		
400	MS51862-13	. Screw	4					X		
400	AN531-6R6	. Screw (Superseded by MS51862-13)	4					X		
410	28-113090-15	. Door Frame, L/H	1					X		
-420	28-113090-16	. Door Frame, R/H	1					X		
430	28-113096-1	. Door Latch, L/H	1					X		
430	28-113085-13	. Door Latch, L/H (Replaced by 28-113096-1)	1					X		
-440	28-113096-2	. Door Latch, R/H	1					X		
-440	28-113085-14	. Door Latch, R/H (Replaced by 28-113096-2)	1					X		
450	28-113084-11	. Door Latch Sleeve	2					X		
460	NP525-10R10	. Screw	2					X		
470	28-113090-17	. Doubler	1					X		
480	MS35207-277	. Screw	2					X		
490	28-113090-19	. Cover, L/H	1					X		
-500	28-113090-20	. Cover, R/H	1					X		
-	4910-50	. Tape	A/R					X		
510	Y9485	. Adhesive Tape	A/R					X		
520	28-113091-5	. Door Handle, L/H	1					X		
-530	28-113091-6	. Door Handle, R/H	1					X		
-540	28-113091-3	. Door Handle Set (Replaced by 28-113091-5 and 28-113091-6)	1					X		
-540	28-113091-1	. Door Handle Set (Replaced by 28-113091-3)	1					X		
-540A	28-113091-3CS	. Door Handle Set	1					X		
550	28-113092-13	. Door Latch Doubler	1					X		
550	28-113092-11	. Door Latch Doubler (Superseded by 28-113092-13)	1					X		

ENSTROM F-28/280 SERIES ILLUSTRATED PARTS CATALOG

FIGURE 7-4. DOOR ASSEMBLY AND INSTALLATION (F-28F S/N 745 & SUB)

ITEM NUMBER	PART NUMBER	DESCRIPTION	QTY PER ASSY	MODELS AFFECTED						
				F-28A	280	F-28C	280C	F-28F	280F	280FX
560	28-113097-3	. Doubler Assembly, L/H	1					X		
-	28-113097-13	. . Door Latch Doubler, L/H	1					X		
-570	28-113097-4	. Doubler Assembly, R/H	1					X		
-	28-113097-14	. . Door Latch Doubler, R/H	1					X		
580	28-11484-11	. Door Strike	1					X		
590	28-113090-27	. Shim	A/R					X		
600	MS51862-14	. Screw	5					X		
600	AN531-6R8	. Screw (Superseded by MS51862-14)	5					X		
610	28-11371-1	. Lock Plate	1					X		
620	28-113080-5	. Door Latch, L/H	1					X		
620	28-113080-3	. Latch Arm, L/H (Superseded by 28-113080-5)	1					X		
-630	28-113080-6	. Door Latch, R/H	1					X		
-630	28-113080-4	. Latch Arm, R/H (Superseded by 28-11380-6)	1					X		
640	28-113090-18	. Door Cover	1					X		
650	NP525-10R12	. Screw	1					X		
660	MS18063-8	. Set Screw	1					X		
670	28-113093-13	. Pulley	1					X		

▲ Assembly and installation post-1986.

* Remove CC-3251 snap vent and 28-11715-11 ring when 28-01042-1 or 28-01042-2 sliding window kit is requested.

ENSTROM F-28/280 SERIES ILLUSTRATED PARTS CATALOG



INTENTIONALLY LEFT BLANK

ENSTROM F-28/280 SERIES ILLUSTRATED PARTS CATALOG

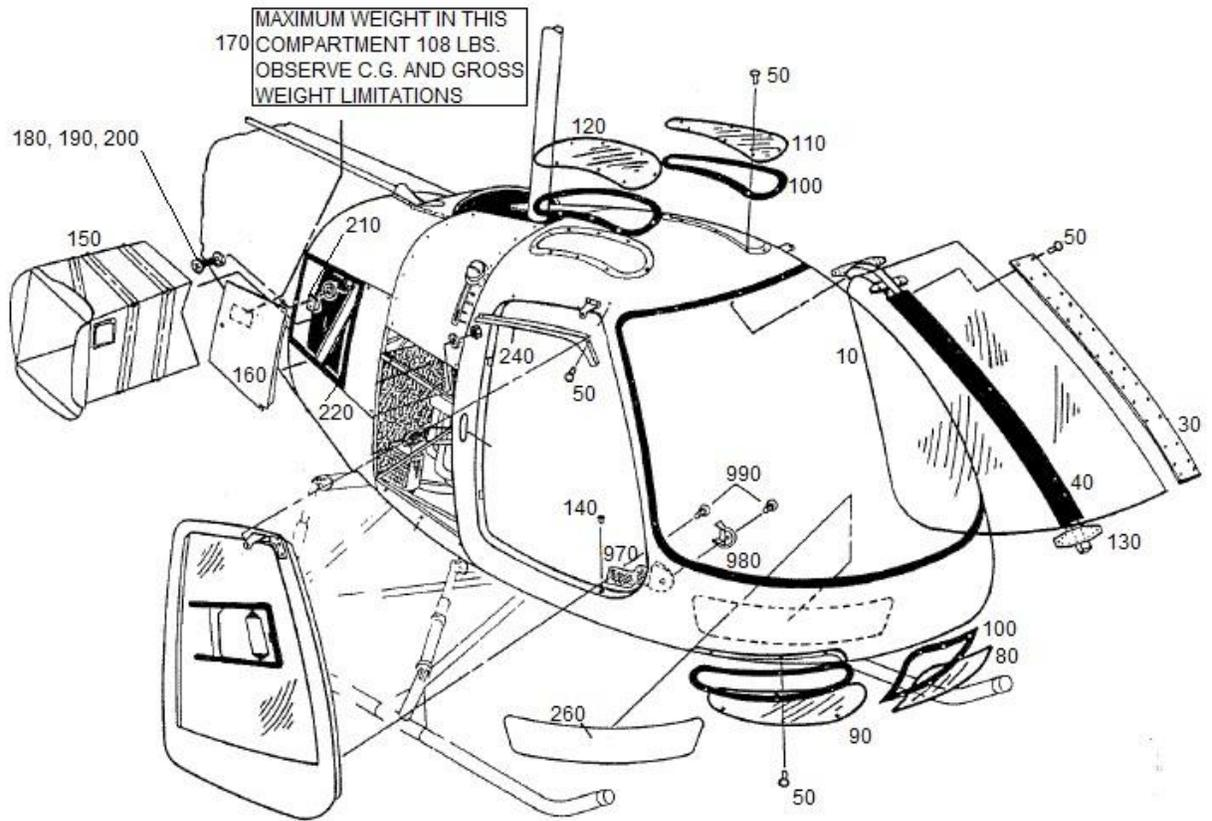

Sheet 1 of 3

FIGURE 7-5. WINDOWS, DOORS, AND COMPARTMENT ENCLOSURES
(280, 280C, 280F, 280FX)

ENSTROM F-28/280 SERIES ILLUSTRATED PARTS CATALOG

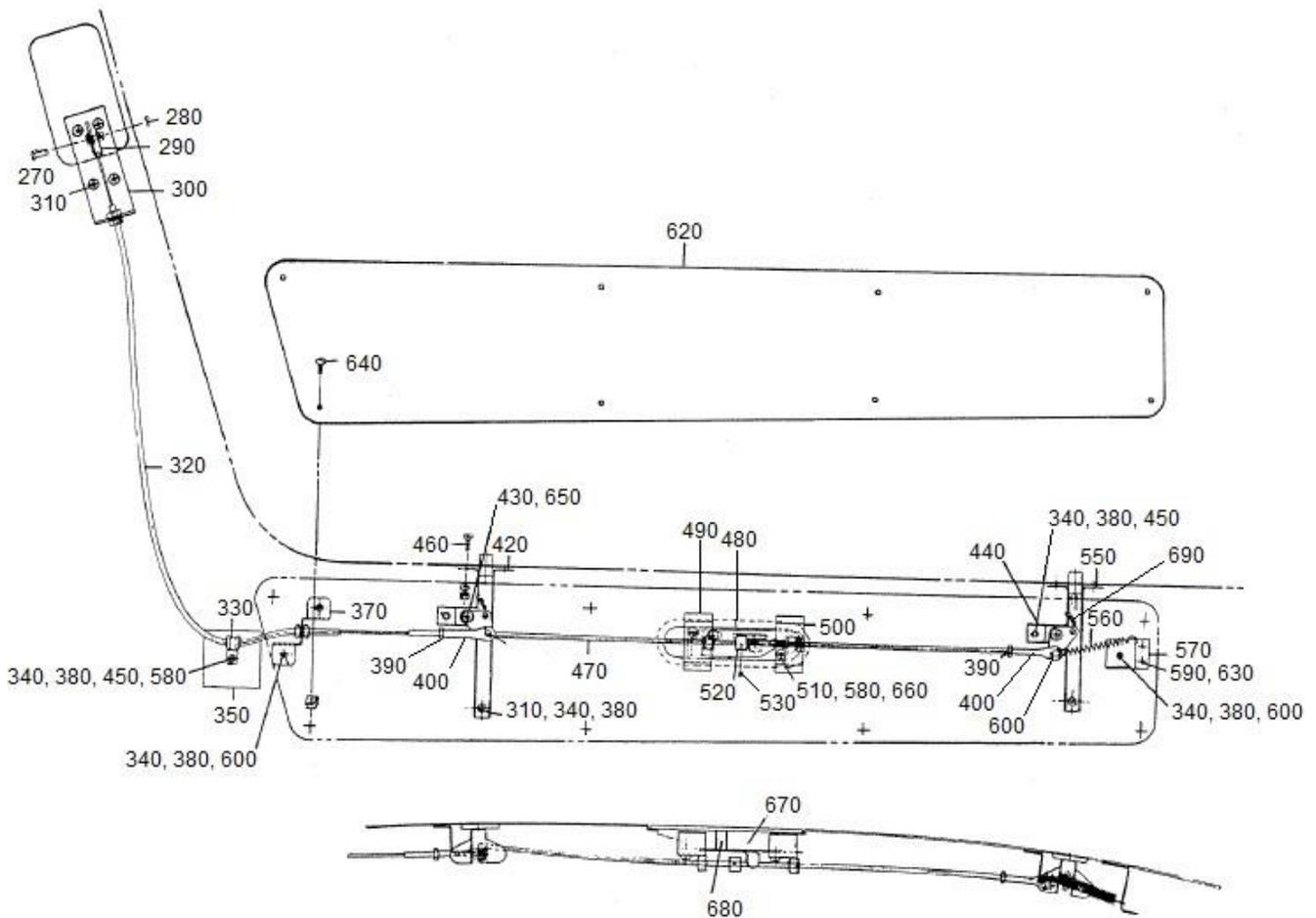

Sheet 2 of 3

FIGURE 7-5. WINDOWS, DOORS, AND COMPARTMENT ENCLOSURES
(280, 280C, 280F, 280FX)

ENSTROM F-28/280 SERIES ILLUSTRATED PARTS CATALOG

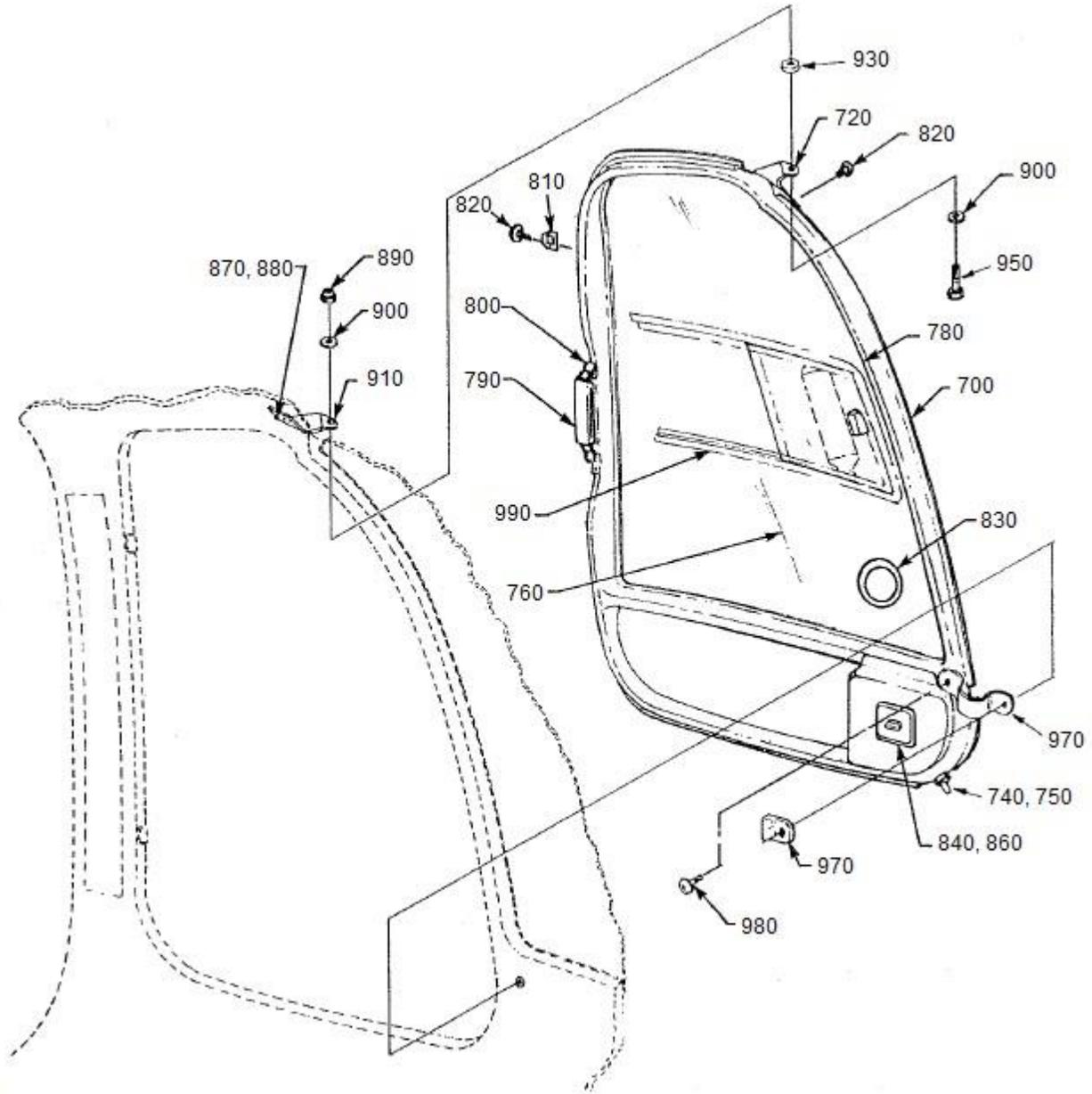

Sheet 3 of 3

FIGURE 7-5. WINDOWS, DOORS, AND COMPARTMENT ENCLOSURES
(280, 280C, 280F, 280FX)

ENSTROM F-28/280 SERIES ILLUSTRATED PARTS CATALOG

FIGURE 7-5. WINDOWS, DOORS, AND COMPARTMENT ENCLOSURES
(280, 280C, 280F, 280FX)

ITEM NUMBER	PART NUMBER	DESCRIPTION	QTY PER ASSY	MODELS AFFECTED						
				F-28A	280	F-28C	280C	F-28F	280F	280FX
-	280-113000-103	Cabin Installation	REF		X		X		X	X
10	280-113022-12	. Windshield, R/H	1		X		X		X	X
-20	280-113022-11	. Windshield, L/H	1		X		X		X	X
30	280-113022-17	. . Stiffener	1		X		X		X	X
40	PR1425B1/2	. . Sealant	A/R		X		X		X	X
40	PR1425B2	. . Sealant (Alternate)	A/R		X		X		X	X
40	4016-1	. . Foam Tape (Replaced by PR1425B1/2)	A/R		X		X		X	X
-	1425	. . Sealant	A/R		X		X		X	X
-	EC-801-807	. . Adhesive (Replaced by 1425)	A/R		X		X		X	X
50	CR91484-4-03	. . Rivet	A/R		X		X		X	X
50	AD43BSLF	. . Rivet (Alternate to CR91484-4-03)	A/R		X		X		X	X
50	CR91484-4-3	. . Rivet (Replaced by CR91484-4-03)	A/R		X		X		X	X
-60	CR91484-4-04	. . Rivet	A/R		X		X		X	X
-60	AD44BSLF	. . Rivet (Alternate to CR91484-4-04)	A/R		X		X		X	X
-60	CR91484-4-4	. . Rivet (Replaced by CR91484-4-04)	A/R		X		X		X	X
-70	CR91484-4-05	. . Rivet	A/R		X		X		X	X
-70	AD45BSLF	. . Rivet (Alternate to CR91484-4-05)	A/R		X		X		X	X
-70	CR91484-4-5	. . Rivet (Replaced by CR91484-5-05)	A/R		X		X		X	X
80	280-113022-13	. . Lower Window, L/H	1		X		X		X	X
90	280-113022-14	. . Lower Window, R/H	1		X		X		X	X
100	4016-75	. . Foam Tape	A/R		X		X		X	X
110	280-113022-15	. . Upper Window, L/H	1		X		X		X	X
120	280-113022-16	. . Upper Window, R/H	1		X		X		X	X
-	280-113001-9	. Cabin Subassembly	1		X		X		X	X
-	280-113023-1	. . Cabin Fiberglass & Seat Structure Assembly	1		X		X		X	X

ENSTROM F-28/280 SERIES ILLUSTRATED PARTS CATALOG

FIGURE 7-5. WINDOWS, DOORS, AND COMPARTMENT ENCLOSURES
(280, 280C, 280F, 280FX)

ITEM NUMBER	PART NUMBER	DESCRIPTION	QTY PER ASSY	MODELS AFFECTED						
				F-28A	280	F-28C	280C	F-28F	280F	280FX
130	280-113024-1	. . . Main Windshield Post Assembly	1		X		X		X	X
140	3-1AF	. . . Bushing	2		X		X		X	X
150	280-128000-2	. Baggage Compartment Installation	1		X		X		X	X
160	280-114507-1	. Baggage Door Assembly	1		X		X		X	
-160A	280-114507-3	. Baggage Door Assembly	1							X
170	28-12830-11	. . Placard	1		X		X		X	X
180	AN525-832R8	. Screw	2		X		X		X	X
180	AN526-832R8	. Screw (Superseded by AN525-832R8)	2		X		X		X	X
190	NAS1149FN816P	. Washer	4		X		X		X	X
190	AN960-8L	. Washer (Alternate)	4		X		X		X	X
200	MS21083N08	. Nut	2		X		X		X	X
200	AN364-832A	. Nut (Superseded by MS21083N08)	2		X		X		X	X
210	280-114500-13	. Catch Plate	1		X		X		X	X
220	4316	. Tape, 3/4" Wide	A/R		X		X		X	X
-230	28-113047-11	. Rain Fairing, L/H	1		X		X		X	X
240	28-113047-12	. Rain Fairing, R/H	1		X		X		X	X
-250	28-113041-11	. Cabin Trim, L/H	1		X		X		X	X
260	28-113041-12	. Cabin Trim, R/H	1		X		X		X	X
-*	280-117000-1	. Cabin Door Lock Assembly, L/H	1		X		X		X	X
-*	280-117000-2	. Cabin Door Lock Assembly, R/H	1		X		X		X	X
270	AN393-11	. . Pin	2		X		X		X	X
280	MS24665-1013	. . Cotter Pin	2		X		X		X	X
280	AN381-2-7	. . Cotter Pin (Superseded by MS24665-1013)	2		X		X		X	X
290	280-117001-15	. . Clevis	1		X		X		X	X
300	280-117001-23	. . Retainer	1		X		X		X	X
310	MS27039-0808	. . Screw	4		X		X		X	X

ENSTROM F-28/280 SERIES ILLUSTRATED PARTS CATALOG

FIGURE 7-5. WINDOWS, DOORS, AND COMPARTMENT ENCLOSURES
(280, 280C, 280F, 280FX)

ITEM NUMBER	PART NUMBER	DESCRIPTION	QTY PER ASSY	MODELS AFFECTED						
				F-28A	280	F-28C	280C	F-28F	280F	280FX
310	AN525-832R8	.. Screw (Superseded by MS27039-0808)	4		X		X		X	X
320	280-117002-1	.. Cable	1		X		X		X	X
330	MS21919-DG3	.. Clamp	1		X		X		X	X
340	NAS1149FN816P	.. Washer	10		X		X		X	X
340	AN960-8L	.. Washer (Alternate)	10		X		X		X	X
350	280-117000-17	.. Backing Plate	2		X		X		X	X
-360	280-117000-25	.. Bracket, L/H	1		X		X		X	X
370	280-117000-26	.. Bracket, R/H	1		X		X		X	X
380	MS21044N08	.. Nut	8		X		X		X	X
380	AN365-832A	.. Nut (Superseded by MS21044N08)	8		X		X		X	X
390	AN315-3R	.. Nut	8		X		X		X	X
400	AN665-21R	.. Clevis	2		X		X		X	X
-410	280-117003-1	.. Latch Assembly, L/H	1		X		X		X	X
420	280-117003-2	.. Latch Assembly, R/H	1		X		X		X	X
430	NAS1149F0332P	.. Washer	4		X		X		X	X
430	AN960-10L	.. Washer (Alternate)	4		X		X		X	X
440	28-13605-4	.. Shim	A/R		X		X		X	X
-440A	28-13605-5	.. Shim	A/R		X		X		X	X
-440B	28-13605-6	.. Shim	A/R		X		X		X	X
-440C	28-13605-7	.. Shim	A/R		X		X		X	X
-440D	28-13605-8	.. Shim	A/R		X		X		X	X
450	MS27039-0810	.. Screw	3		X		X		X	X
450	AN525-832R10	.. Screw (Superseded by MS27039-0810)	3		X		X		X	X
460	AN507-1032-8	.. Screw	4		X		X		X	X
470	280-117003-27	.. Push Rod Assembly	1		X		X		X	X
480	280-117001-3	.. Latch	1		X		X		X	X
490	280-117001-7	.. Latch Retainer	1		X		X		X	X

ENSTROM F-28/280 SERIES ILLUSTRATED PARTS CATALOG

FIGURE 7-5. WINDOWS, DOORS, AND COMPARTMENT ENCLOSURES
(280, 280C, 280F, 280FX)

ITEM NUMBER	PART NUMBER	DESCRIPTION	QTY PER ASSY	MODELS AFFECTED						
				F-28A	280	F-28C	280C	F-28F	280F	280FX
500	280-117001-5	.. Latch Retainer	1		X		X		X	X
510	AN526-1032R8	.. Screw	2		X		X		X	X
520	280-117001-25	.. Latch Stop	1		X		X		X	X
530	8-32X1/4 IN	.. Screw	1		X		X		X	X
-540	280-117003-3	.. Latch Retainer, L/H	1		X		X		X	X
550	280-117003-4	.. Latch Retainer, R/H	1		X		X		X	X
560	280-117000-10	.. Spring (CS-31)	1		X		X		X	X
570	280-117000-15	.. Bracket	1		X		X		X	X
580	NAS1149F0363P	.. Washer	4		X		X		X	X
580	AN960-10	.. Washer (Alternate)	4		X		X		X	X
590	MS51862-13	.. Screw	2		X		X		X	X
590	AN531-6-6	.. Screw (Superseded by MS51862-13)	2		X		X		X	X
600	MS27039-0807	.. Screw	5		X		X		X	X
600	AN525-832R7	.. Screw (Superseded by MS27039-0807)	5		X		X		X	X
-610	280-113038-11	.. Panel, L/H	1		X		X		X	X
620	280-113038-12	.. Panel, R/H	1		X		X		X	X
630	A1785-6Z1D	.. Tinnerman Nut	2		X		X		X	X
640	MS51861-25	.. Screw	8		X		X		X	X
640	AN530-6R8	.. Screw (Superseded by MS51861-25)	8		X		X		X	X
650	NK525-1032R12	.. Screw	2		X		X		X	X
660	AN935-10L	.. Lock Washer	2		X		X		X	X
670	H2532-13	.. Door Latch (Exterior)	1		X		X		X	X
-	H2532-15	.. Door Latch (L/H Interior)	1		X		X		X	X
-	H2532-16	.. Door Latch (R/H Interior)	1		X		X		X	X
680	ECD060-5	.. Lock Tumbler	1		X		X		X	X
680	110927-3	.. Tumbler Assembly (Replaced by ECD060-5)	1		X		X		X	X
690	LE-026B-00MW	.. Spring	2		X		X		X	X

ENSTROM F-28/280 SERIES ILLUSTRATED PARTS CATALOG

FIGURE 7-5. WINDOWS, DOORS, AND COMPARTMENT ENCLOSURES
(280, 280C, 280F, 280FX)

ITEM NUMBER	PART NUMBER	DESCRIPTION	QTY PER ASSY	MODELS AFFECTED						
				F-28A	280	F-28C	280C	F-28F	280F	280FX
700	280-113027-1	. Door Assembly, L/H	1		X		X		X	X
-710	280-113027-2	. Door Assembly, R/H	1		X		X		X	X
720	280-113027-23	. . Hinge, L/H	1		X		X		X	X
-730	280-113027-24	. . Hinge, R/H	1		X		X		X	X
740	280-113027-31	. . Hinge Pin	1		X		X		X	X
750	AN345-1032	. . Nut	1		X		X		X	X
760	280-113027-13	. . Door Plexiglass, L/H	1		X		X		X	X
-770	280-113027-14	. . Door Plexiglass, R/H	1		X		X		X	X
780	2500-4	. . Weather Strip	A/R		X		X		X	X
-	28-113102-1	. . Door Handle Assembly	1		X		X		X	X
790	28-113102-11	. . . Door Handle	1		X		X		X	X
800	NK525-832R10	. . Screw	2		X		X		X	X
810	280-113039-11	. . Latch Striker	2		X		X		X	X
820	MS27039-0808	. . Screw	8		X		X		X	X
820	AN525-832R8	. . Screw (Superseded by MS27039-0808)	8		X		X		X	X
830	CC-3251	. . Snap Vent	1		X		X		X	X
-	28-11715-11	. . Ring	1		X		X		X	X
840▲	280-113035-1	. . Ash Tray Receptacle Assembly, L/H	1		X		X		X	X
-▲	280-113035-11	. . . Receptacle Door, L/H	1		X		X		X	X
-850▲	280-113035-2	. . Ash Tray Receptacle Assembly, R/H	1		X		X		X	X
-▲	280-113035-12	. . . Receptacle Door, R/H	1		X		X		X	X
860▲	MS51861-24	. . Screw	2		X		X		X	X
860▲	AN530-6R6	. . Screw (Superseded by MS51861-24)	2		X		X		X	X
870	NAS6603-4	. . Bolt	2		X		X		X	X

ENSTROM F-28/280 SERIES ILLUSTRATED PARTS CATALOG

FIGURE 7-5. WINDOWS, DOORS, AND COMPARTMENT ENCLOSURES
(280, 280C, 280F, 280FX)

ITEM NUMBER	PART NUMBER	DESCRIPTION	QTY PER ASSY	MODELS AFFECTED						
				F-28A	280	F-28C	280C	F-28F	280F	280FX
870	AN3-5A	. . Bolt (Superseded by NAS6603-4)	2		X		X		X	X
880	NAS1149F0332P	. . Washer	2		X		X		X	X
880	AN960-10L	. . Washer (Alternate)	2		X		X		X	X
890	MS21044N4	. . Nut	1		X		X		X	X
890	AN365-428A	. . Nut (Superseded by MS21044N4)	1		X		X		X	X
900	NAS1149F0463P	. . Washer	2		X		X		X	X
900	AN960-416	. . Washer (Alternate)	2		X		X		X	X
910	280-113032-11	. Hinge Bracket, L/H	1		X		X		X	X
-920	280-113032-12	. Hinge Bracket, R/H	1		X		X		X	X
930	28-16210-3	. Spacer	A/R		X		X		X	X
-940	28-16211-1	. Spacer	A/R		X		X		X	X
950	NAS6604-7	. Bolt	1		X		X		X	X
950	AN4-7A	. Bolt (Superseded by NAS6604-7)	1		X		X		X	X
960	280-113036-1	. Restraint Strap Assembly	1		X		X		X	X
-	280-113036-11	. . Restraint Strap	1		X		X		X	X
-960A	280-113036-3	. Restraint Strap Assembly	1		X		X		X	X
-	280-113036-13	. . Restraint Strap	1		X		X		X	X
-960B	280-113036-5	. Restraint Strap Assembly	1		X		X		X	X
-	280-113036-15	. . Restraint Strap	1		X		X		X	X
970	280-113037-13	. Restraint Strap Guide	1		X		X		X	X
970	280-113037-11	. Restraint Strap Guide (Superseded by 280-113037-13)	1		X		X		X	X
970	280-113037-1	. Restraint Strap Guide (Superseded by 280-113037-11)	1		X		X		X	X
980	NK525-10R12	. Screw	2		X		X		X	X
990▲	28-113046-3	. Sliding Window Kit, L/H	1		X		X		X	X
-1000▲	28-113046-4	. Sliding Window Kit, R/H	1		X		X		X	X

ENSTROM F-28/280 SERIES ILLUSTRATED PARTS CATALOG

- * All hardware quantities are for one cabin door lock assembly.
- ▲ Optional equipment.

ENSTROM F-28/280 SERIES ILLUSTRATED PARTS CATALOG

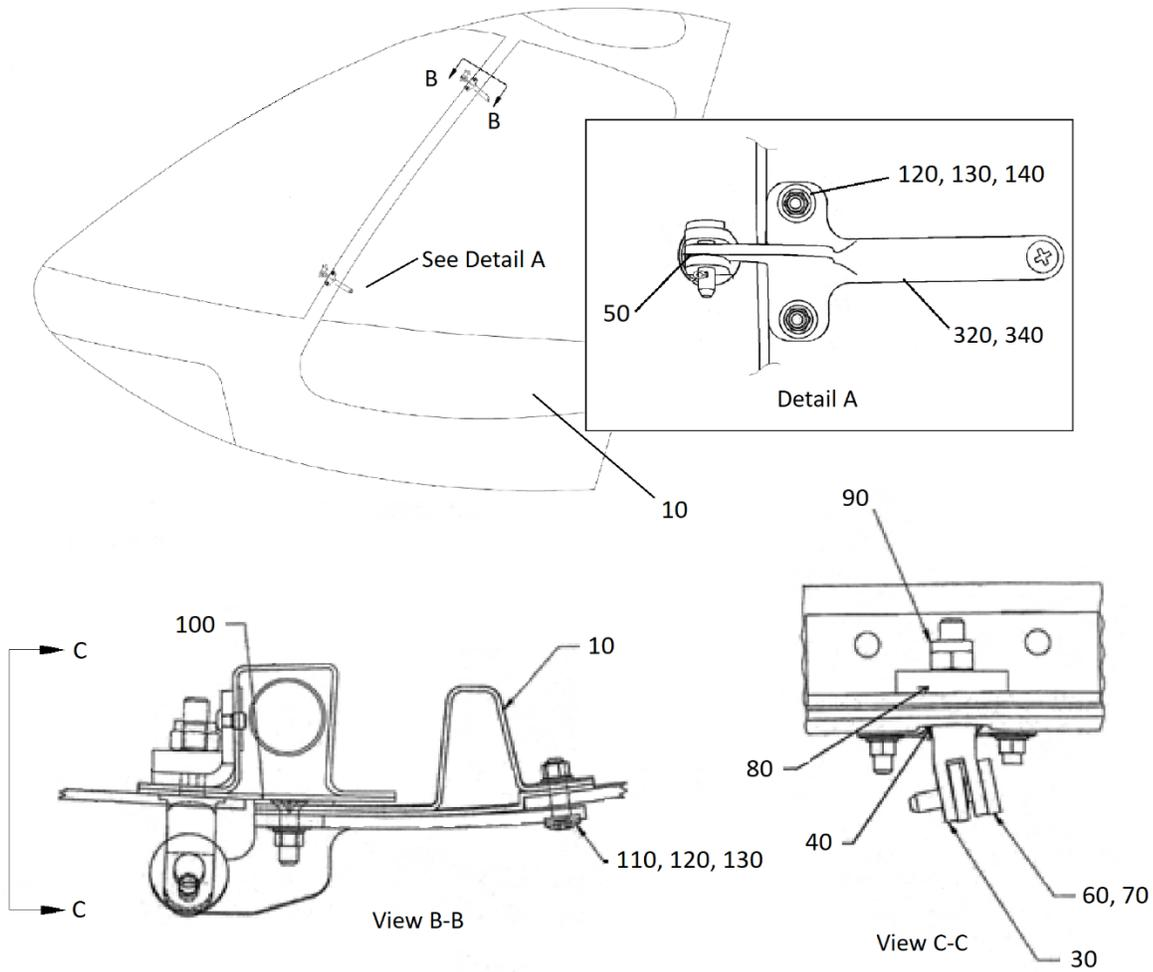

Sheet 1 of 3

FIGURE 7-6. 280FX CABIN DOORS ASSEMBLY/INSTALLATION

ENSTROM F-28/280 SERIES ILLUSTRATED PARTS CATALOG

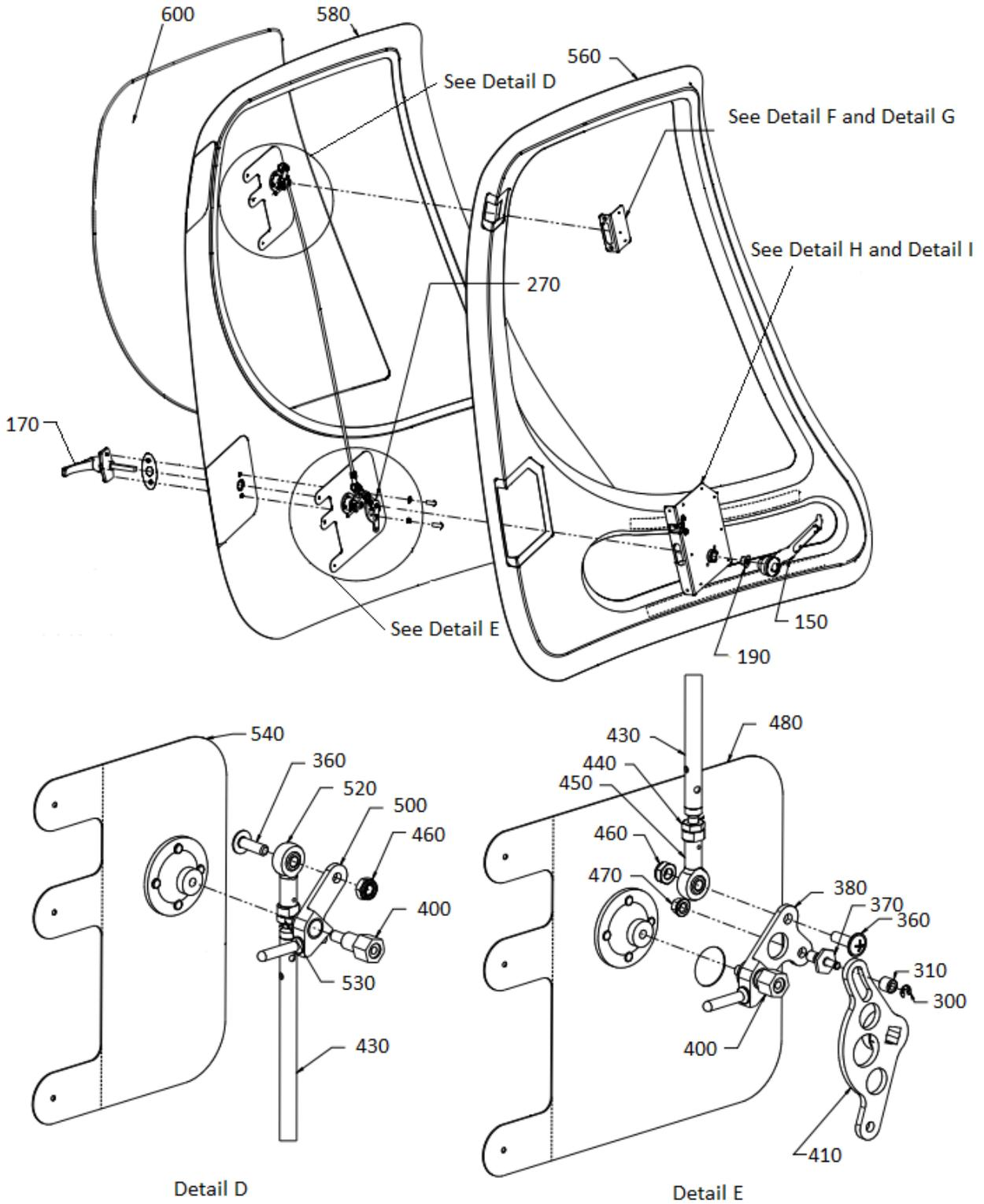

Sheet 2 of 3

FIGURE 7-6. 280FX CABIN DOORS ASSEMBLY/INSTALLATION

ENSTROM F-28/280 SERIES ILLUSTRATED PARTS CATALOG

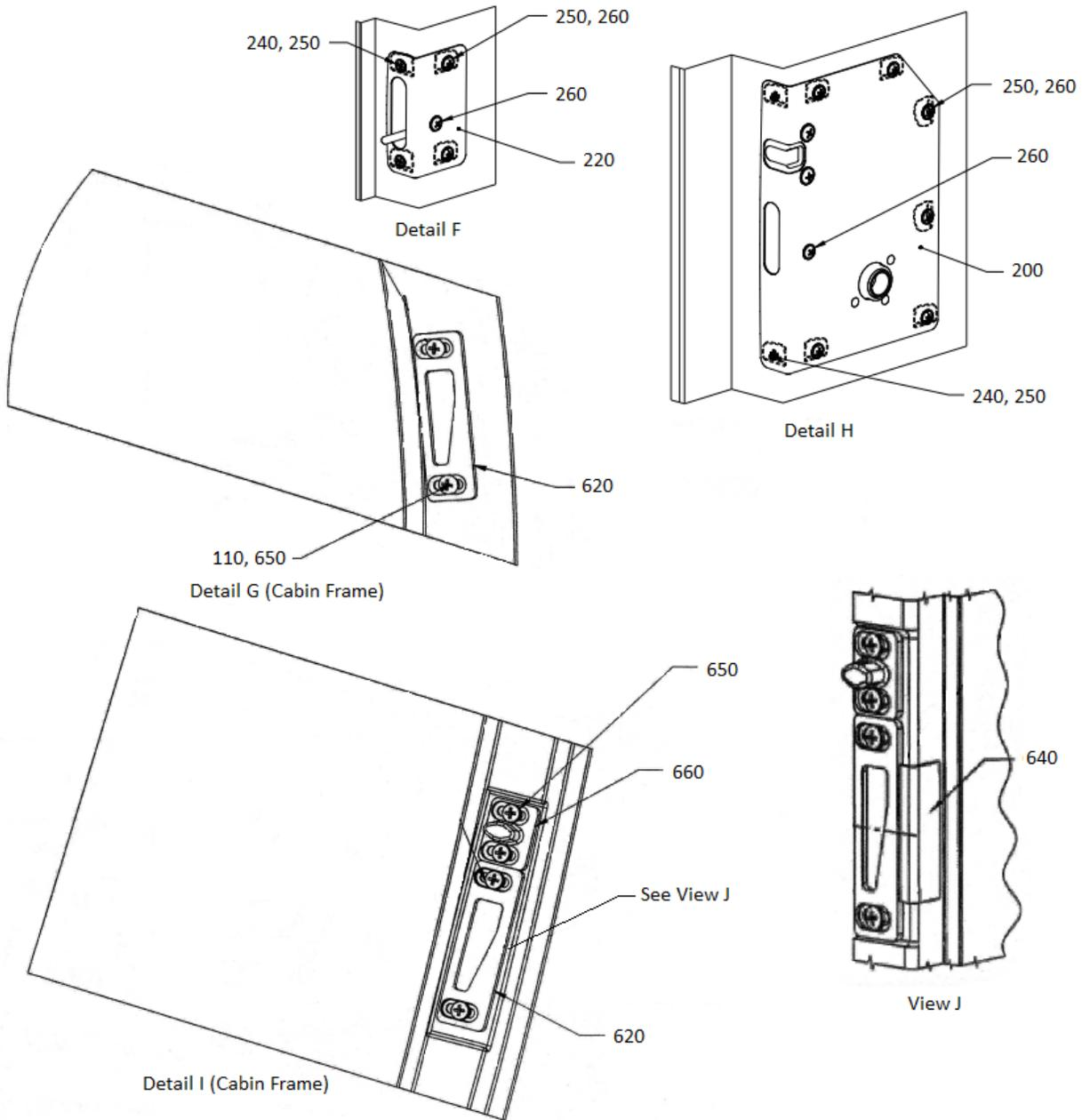

FIGURE 7-6. 280FX CABIN DOORS ASSEMBLY/INSTALLATION

ENSTROM F-28/280 SERIES ILLUSTRATED PARTS CATALOG

FIGURE 7-6. 280FX CABIN DOORS ASSEMBLY/INSTALLATION

ITEM NUMBER	PART NUMBER	DESCRIPTION	QTY PER ASSY	MODELS AFFECTED						
				F-28A	280	F-28C	280C	F-28F	280F	280FX
10▲	28-113139-1	Bonded Door Assy - LH	1							X
-20▲	28-113139-2	Bonded Door Assy - RH	1							X
30	4118278-23	. Hinge Post	4							X
40	ECD050-11	. Washer	A/R							X
50	4118283-11	. Hinge Bushing	4							X
60	MS20392-2C17	. Clevis Pin	4							X
70	AN381-2-10	. Cotter Pin	4							X
-75	MS17984C305	. Quick Release Pin (Alternate for MS20392-2C17 & AN381-2-10)	A/R							X
80	4118278-21	. Radius Block	4							X
90	MS21044N4	. Nut	4							X
100	4118284-13	. Hinge Doubler	4							X
110	MS27039-1-09	. Screw	16							X
120	NAS1149D0316H	. Washer	12							X
130	MS21042-3	. Nut	12							X
140	MS24694-S52	. Screw	8							X
150	28-113122-1	. Door Handle Assy - LH	1							X
-160	28-113122-2	. Door Handle Assy - RH	1							X
170	28-113122-3	. Outside Handle Assy (LH)	1							X
-175	ECD060-11	. Handle (LH) (Superseded by 28-113122-3)	1							X
-180	28-113122-4	. Outside Handle Assy (RH)	1							X
-185	ECD060-12	. Handle (RH) (Superseded by 28-113122-4)	1							X
190	4118265-21	. Bushing	1							X
200	28-113114-1	. Lower Door Cover Assy - LH	1							X
-210	28-113114-2	. Lower Door Cover Assy - RH	1							X
220	28-113118-11	. Upper Door Cover - LH	1							X
-230	28-113118-12	. Upper Door Cover - RH	1							X
240	MS24693-S48	. Screw	4							X
250	CB6009CR08-1P	. Click Bond Nutplate	12							X

ENSTROM F-28/280 SERIES ILLUSTRATED PARTS CATALOG

FIGURE 7-6. 280FX CABIN DOORS ASSEMBLY/INSTALLATION

ITEM NUMBER	PART NUMBER	DESCRIPTION	QTY PER ASSY	MODELS AFFECTED						
				F-28A	280	F-28C	280C	F-28F	280F	280FX
260	AN525-832R6	. Screw	10							X
270	MS18066-8	. Set Screw	1							X
-280	X1543HT	. Seal	A/R							X
-290	4119839-11	. Placard	1							X
300	MS16633-4012	. Retaining Ring	1							X
310	28-113113-13	. Cam Roller	1							X
320	28-113135-11	. Door Hinge - Upper LH	1							X
-330	28-113135-12	. Door Hinge - Upper RH	1							X
340	28-113136-11	. Door Hinge - Lower LH	1							X
-350	28-113136-12	. Door Hinge - Lower RH	1							X
360	AN525-10R10	. Screw	2							X
370	28-113113-11	. Cam Pin & Stud	1							X
380	28-113101-3	. Lower Bellcrank Assy - LH	1							X
-390	28-113101-4	. Lower Bellcrank Assy - RH	1							X
400	28-113120-11	. Shoulder Screw	2							X
410	28-113112-11	. Cam Lever Arm - LH	1							X
-420	28-113112-12	. Cam Lever Arm - RH	1							X
430	28-113140-1	. Push Pull Rod Weldment	1							X
440	AN315-3L	. LH Nut	1							X
450	ALJFL3T	. LH Rod End	1							X
-455	60685K31	. LH Rod End (Alternate for ALJFL3T)	2							X
460	MS21083N3	. Nut	2							X
470	MS21042-3	. Nut	1							X
480	28-113103-3	. Lower Doubler Assy - LH	1							X
-490	28-113103-4	. Lower Doubler Assy -RH	1							X
500	28-113101-1	. Upper Bellcrank Assy - LH	1							X
-510	28-113101-2	. Upper Bellcrank Assy - RH	1							X

ENSTROM F-28/280 SERIES ILLUSTRATED PARTS CATALOG

FIGURE 7-6. 280FX CABIN DOORS ASSEMBLY/INSTALLATION

ITEM NUMBER	PART NUMBER	DESCRIPTION	QTY PER ASSY	MODELS AFFECTED						
				F-28A	280	F-28C	280C	F-28F	280F	280FX
520	ALJF3T	. RH Rod End	1							X
-525	60685K31	. RH Rod End (Alternate for ALJF3T)	1							X
530	AN315-3R	. RH Nut	1							X
540	28-113103-1	. Upper Doubler Assy - LH	1							X
-550	28-113103-2	. Upper Doubler Assy - RH	1							X
560	28-113125-11	. Door Skin Doubler - LH	1							X
-570	28-113125-12	. Door Skin Doubler - RH	1							X
580	28-113124-11	. Door Skin - LH	1							X
-590	28-113124-12	. Door Skin - RH	1							X
600	28-113134-11	. LH Door Window	1							X
-610	28-113134-12	. RH Door Window	1							X
620	4118290-16	. Strike	2							X
-630	4118290-15	. Strike	2							X
640	28-113129-11	. Strike Guard	1							X
650	A10K166	. Rivnut	12							X
660	28-113128-11	. Door Guide	2							X

▲ Effectivity and eligibility 280FX S/N 2147, 2168, and subsequent.

Note: All quantities listed are per door.

ENSTROM F-28/280 SERIES ILLUSTRATED PARTS CATALOG

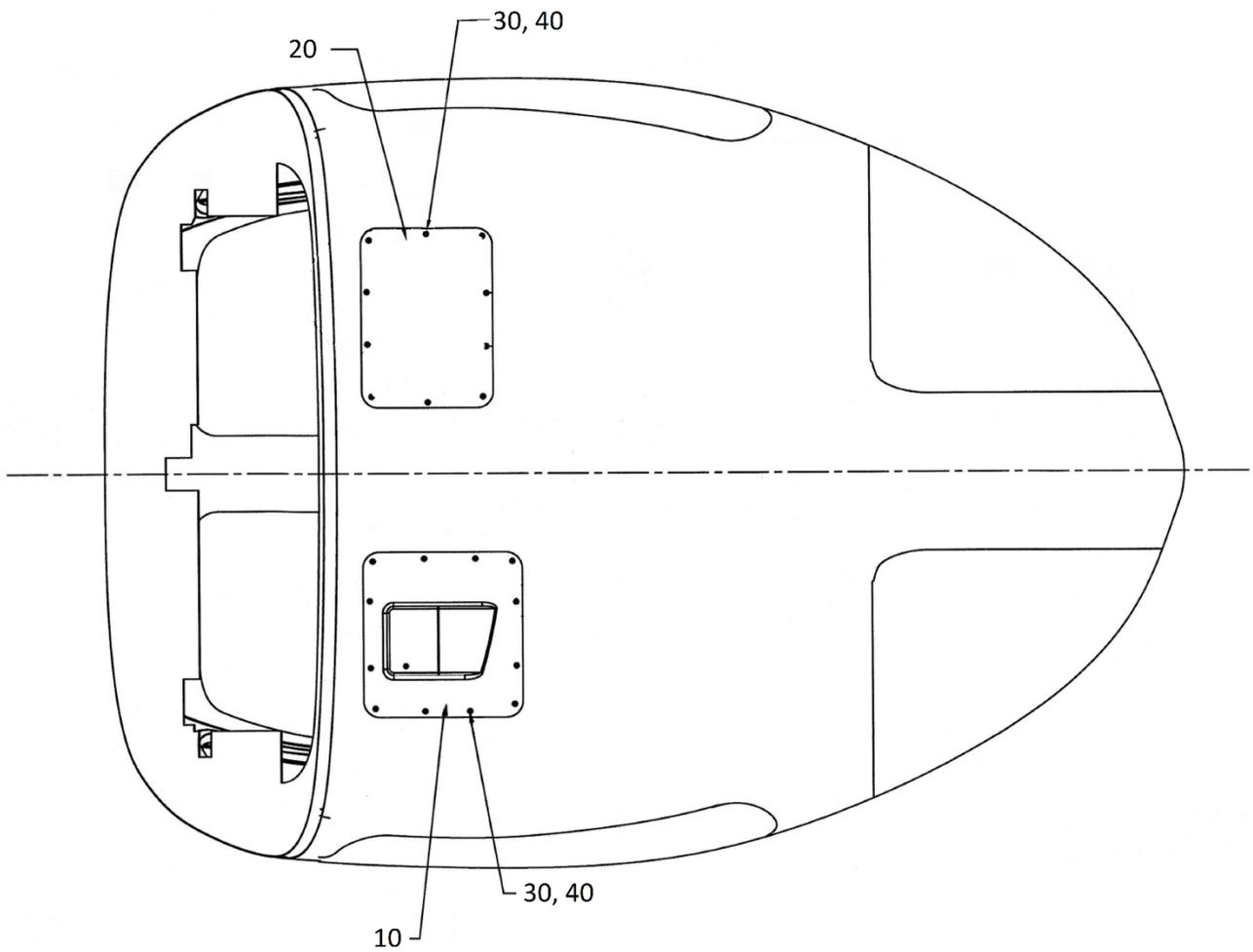

FIGURE 7-7. 280FX CABIN CLOSEOUT INSTALLATION

ENSTROM F-28/280 SERIES ILLUSTRATED PARTS CATALOG

FIGURE 7-7. 280FX CABIN CLOSEOUT INSTALLATION

ITEM NUMBER	PART NUMBER	DESCRIPTION	QTY PER ASSY	MODELS AFFECTED						
				F-28A	280	F-28C	280C	F-28F	280F	280FX
-▲	28-113055-1	Closeout Installation	REF							X
10	28-113054-1	. Closeout Assembly	1							X
20	28-113054-12	. Closeout	1							X
30	8 X 3/8	. Screw	22							X
40	A01787-8Z-1D	. Tinnerman Nut	22							X

▲ Effectivity and eligibility 280FX S/N 2168 and subsequent.

ENSTROM F-28/280 SERIES ILLUSTRATED PARTS CATALOG

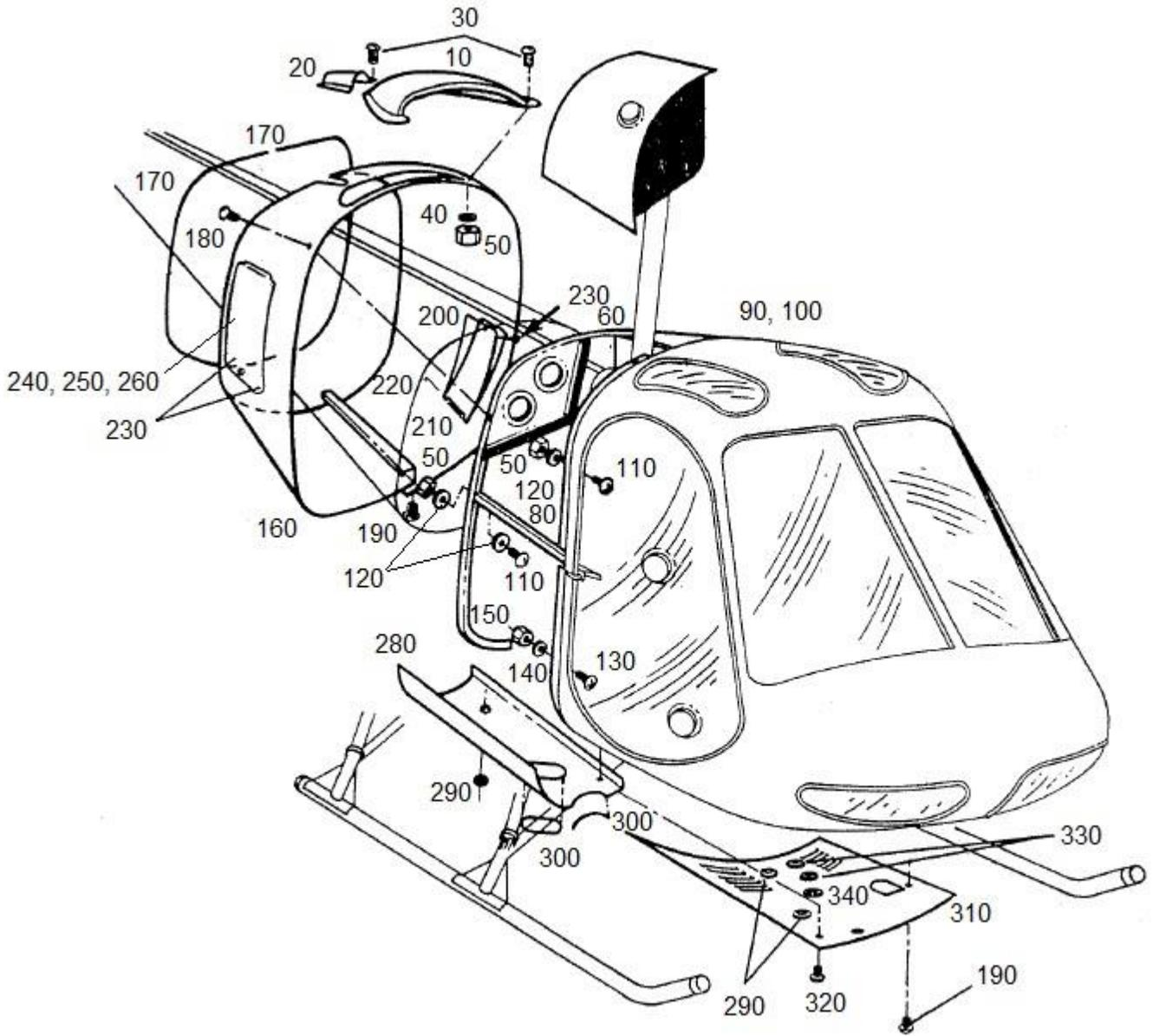

FIGURE 7-8. COWLING (F-28A, F-28C)

ENSTROM F-28/280 SERIES ILLUSTRATED PARTS CATALOG

FIGURE 7-8. COWLING (F-28A, F-28C)

ITEM NUMBER	PART NUMBER	DESCRIPTION	QTY PER ASSY	MODELS AFFECTED						
				F-28A	280	F-28C	280C	F-28F	280F	280FX
-	28-11400-1	Cowl Assembly	1	X	X	X	X	X	X	
10	28-11401-3	. Airscoop	1	X		X	X	X	X	
20	28-11402-1	. Fairing, Tail Rotor Drive Shaft	1	X	X	X	X	X	X	
30	AN525-832R8	. Screw	24	X	X	X	X	X	X	
30	AN526-832R8	. Screw (Superseded by AN525-832R8)	24	X	X	X	X	X	X	
40	NAS1149FN816P	. Washer	24	X	X	X	X	X	X	
40	AN960-8L	. Washer (Alternate)	24	X	X	X	X	X	X	
50	MS21044N08	. Nut	56	X	X	X	X	X	X	
50	AN365-832A	. Nut (Superseded by MS21044N08)	56	X	X	X	X	X	X	
60	28-11420-1	. Cowl Ring Assembly	1	X		X				
-70	28-11413-3	. Support L/H	1	X		X				
80	28-11413-4	. Support R/H	1	X		X				
90	28-11413-9	. Mount, Tank	1	X		X				
-90A	28-11413-10	. Mount, Tank	1	X		X				
100	28-11413-11	. Mount, Cowl	1	X		X				
-100A	28-11413-12	. Mount, Cowl	1	X		X				
-100B	28-11413-13	. Mount, Cowl	1	X		X				
110	MS27039-0806	. Screw	32	X		X				
110	AN525-832R6	. Screw (Superseded by MS27039-0806)	32	X		X				
120	NAS1149FN832P	. Washer	36	X		X				
120	AN960-8	. Washer (Alternate)	36	X		X				
130	AN536-632R6	. Screw	40	X		X				
140	NAS1149FN616P	. Washer	40	X		X				
140	AN960-6L	. Washer (Alternate)	40	X		X				
150	MS21044N06	. Nut	40	X		X				
150	AN365-632A	. Nut (Superseded by MS21044N06)	40	X		X				

ENSTROM F-28/280 SERIES ILLUSTRATED PARTS CATALOG

FIGURE 7-8. COWLING (F-28A, F-28C)

ITEM NUMBER	PART NUMBER	DESCRIPTION	QTY PER ASSY	MODELS AFFECTED						
				F-28A	280	F-28C	280C	F-28F	280F	280FX
160	28-11403-1	. Wraparound Cowl	1	X		X				
170	980-003	. Channel (X-397)	A/R	X		X				
180	AN526-832-8	. Screw	12	X		X				
190	#8x1/2	. Truss Head Screw Type B	21	X		X				
200	28-11442-1	. Door, Inspection	1	X		X				
210	MS20257-1	. Hinge, Piano	1	X		X				
220	MS20253-1	. Pin, Hinge	1	X		X				
230	82-12-120-16	. Stud, Wing	4	X		X				
240	43-13-1-24	. Spring, Ejector	4	X		X				
250	82-32-101-20	. Retainer, Split Ring	4	X		X				
260	82-46-101-39	. Washer, Wear	4	X		X				
-270	28-11405-1	. Side Cowl, L/H Bottom	1	X		X				
280	28-11405-2	. Side Cowl, R/H Bottom	1	X		X				
290	AN931-12-17	. Grommet	5	X		X				
300	980-001	. Channel (X-142)	A/R	X		X				
310	28-11409-1	. Cowl Panel, Bottom	1	X		X				
320	AN525-8R8	. Screw	7	X		X				
330	AN931-10-14	. Grommet	2	X		X				
340	AN931-8-13	. Grommet	3	X		X				

ENSTROM F-28/280 SERIES ILLUSTRATED PARTS CATALOG

|

INTENTIONALLY LEFT BLANK

ENSTROM F-28/280 SERIES ILLUSTRATED PARTS CATALOG

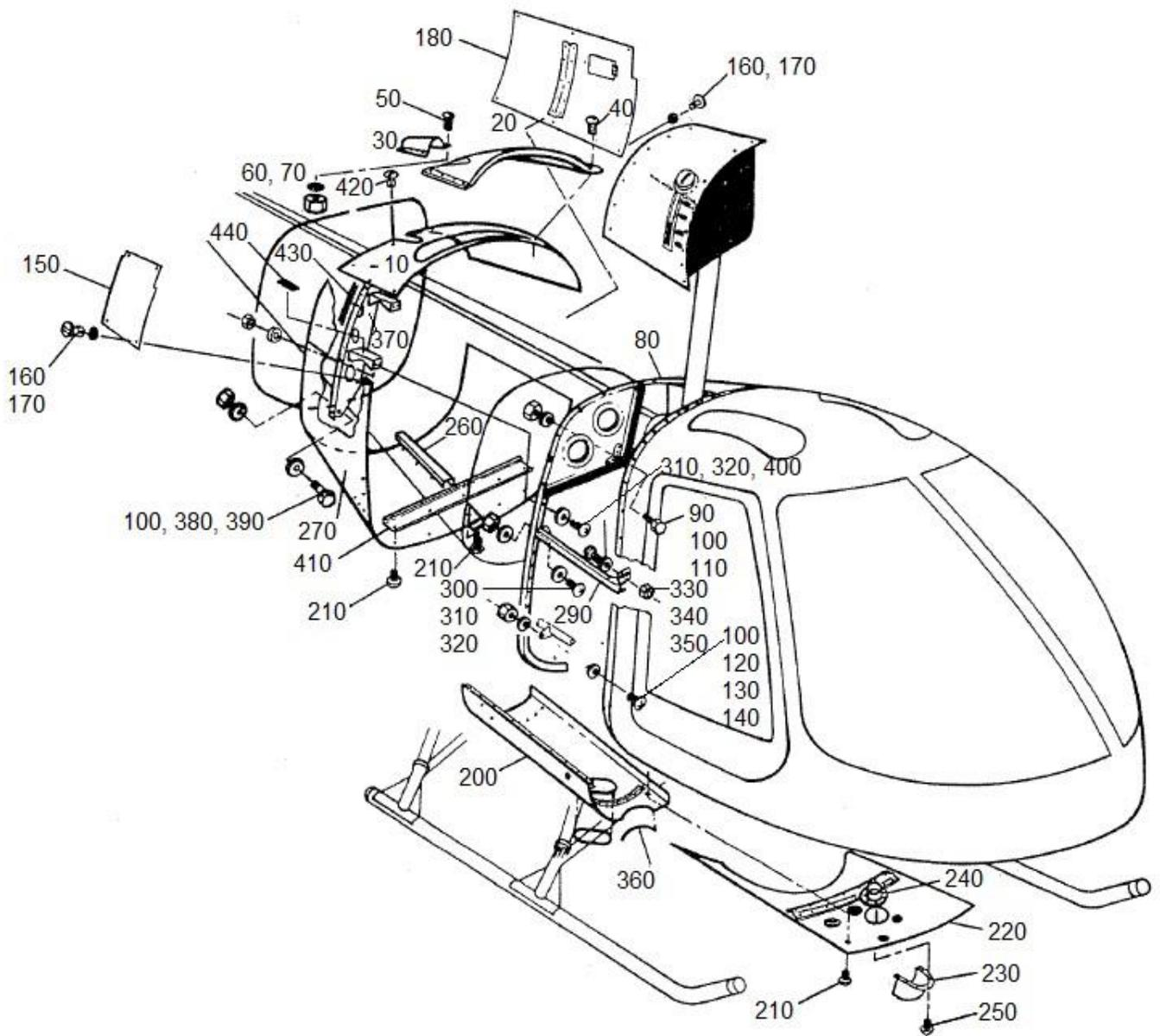

FIGURE 7-9. COWLING (280, 280C)

ENSTROM F-28/280 SERIES ILLUSTRATED PARTS CATALOG

FIGURE 7-9. COWLING (280, 280C)

ITEM NUMBER	PART NUMBER	DESCRIPTION	QTY PER ASSY	MODELS AFFECTED						
				F-28A	280	F-28C	280C	F-28F	280F	280FX
10	280-114501-1	Upper Cowling Assembly	1		X		X			
20*	280-114509-1	. Airscoop	1		X		X			
30	28-11402-1	. Fairing, Tail Rotor Drive Shaft	1		X		X			
40	MS20470AD3-4	. Rivet	A/R		X		X			
50	MS35206-228	. Screw	5		X		X			
50	AN526-632R6	. Screw (Superseded by MS35206-228)	5		X		X			
60	NAS1149FN616P	. Washer	5		X		X			
60	AN960-6L	. Washer (Alternate)	5		X		X			
70	MS21044N06	. Nut	5		X		X			
70	AN365-632A	. Nut (Superseded by MS21044N06)	5		X		X			
80	28-11460-3	. Aft Cowl Ring (F-28C-2)	1		X	X	X	X	X	X
90	NAS6603-4	. Bolt	2	X	X	X	X	X	X	X
90	AN3-5A	. Bolt (Superseded by NAS6603-4)	2	X	X	X	X	X	X	X
100	NAS1149F0332P	. Washer	A/R	X	X	X	X	X	X	X
100	AN960-10L	. Washer (Alternate)	A/R	X	X	X	X	X	X	X
110	MS21044N3	. Nut	2	X	X	X	X	X	X	X
110	AN365-1032A	. Nut (Superseded by MS21044N3)	2	X	X	X	X	X	X	X
120	AN520-10-9	. Screw	2	X	X	X	X	X	X	X
130	NAS1149F0363P	. Washer	A/R	X	X	X	X	X	X	X
130	AN960-10	. Washer (Alternate)	A/R	X	X	X	X	X	X	X
140	MS21083N3	. Nut	2		X		X			
140	AN364-1032A	. Nut (Superseded by MS21083N3)	2		X		X			
150	280-114504-1	. Step Cover Assembly	1		X		X			
160	AJ4-30	. Stud	10		X		X			
170	GA4-250	. Grommet	10		X		X			
180	280-114502-5	. Side Cowl Assembly	1		X		X			
-190	280-114503-3	. Lower Quarter Panel, L/H	1		X		X			
200	280-114503-4	. Lower Quarter Panel, R/H	1		X		X			

ENSTROM F-28/280 SERIES ILLUSTRATED PARTS CATALOG

FIGURE 7-9. COWLING (280, 280C)

ITEM NUMBER	PART NUMBER	DESCRIPTION	QTY PER ASSY	MODELS AFFECTED						
				F-28A	280	F-28C	280C	F-28F	280F	280FX
210	MS51861-35	. Screw	A/R		X		X			
210	AN530-8R8	. Screw (Superseded by MS51861-35)	A/R		X		X			
220	280-114503-1	. Lower Center Cowl	1		X		X			
230	28-12706-11	. Hot Air Deflector	1		X		X			
230	28-12706-1	. Hot Air Deflector (Replaced by 28-12706-11)	1		X		X			
240	28-12305-1	. Stub	1		X		X			
250	MS20470AD4-4	. Rivet	A/R		X		X			
260	280-114503-5	. Aft Cowl Assembly, L/H	1		X		X			
270	280-114503-6	. Aft Cowl Assembly, R/H	1		X		X			
-280	280-114500-17	. Channel, L/H	1		X		X			
290	280-114500-18	. Channel, R/H	1		X		X			
300	MS35206-245	. Screw	4		X		X			
300	AN515-8R8	. Screw (Superseded by MS35206-245)	4		X	X	X	X	X	X
310	NAS1149FN816P	. Washer	26		X	X	X	X	X	X
310	AN960-8L	. Washer (Alternate)	26		X	X	X	X	X	X
320	MS21044N08	. Nut	16		X	X	X	X	X	X
320	AN365-832A	. Nut (Superseded by MS21044N08)	16		X	X	X	X	X	X
330	AN525-1032-8	. Screw	2		X	X	X	X	X	X
340	NAS1149D0363J	. Washer	2		X	X	X	X	X	X
340	AN960PD10	. Washer (Alternate)	2		X	X	X	X	X	X
350	MS21044N3	. Nut	4		X	X	X	X	X	X
350	AN365-1032A	. Nut (Superseded by MS21044N3)	4		X	X	X	X	X	X
-	AN525-8R7	. Bolt	2		X	X	X	X	X	X
360	980-001	. Channel (X-142)	A/R		X	X	X	X	X	X
370**	280-114505-2	. Step Assembly Cowl	1		X	X	X	X	X	X
380	NAS66032	. Bolt	2		X	X	X	X	X	X

ENSTROM F-28/280 SERIES ILLUSTRATED PARTS CATALOG

FIGURE 7-9. COWLING (280, 280C)

ITEM NUMBER	PART NUMBER	DESCRIPTION	QTY PER ASSY	MODELS AFFECTED						
				F-28A	280	F-28C	280C	F-28F	280F	280FX
380	AN3-4A	. Bolt (Superseded by NAS66032)	2		X	X	X	X	X	X
390	AN364-W33A	. Nut	2		X	X	X	X	X	X
400	MS35206-245	. Screw	10		X	X	X	X	X	X
400	AN515-8R8	. Screw (Superseded by MS35206-245)	10		X	X	X	X	X	X
410	280-114508-1	. Aft Cowl Support	1		X	X	X	X	X	X
410**	280-114508-11	. Aft Cowl Support (Replaced by 280-114508-1)	1		X	X	X	X	X	X
420	82-11-120-16	. Stud	4		X	X	X	X	X	X
430	#4316	. 1/16" x 3/4" Tape	A/R		X	X	X	X	X	X
440	28-17006-13	. Non-Slip Surface Tape	2		X	X	X	X	X	X

* Early model 280C.

** Late model F-28C-2.

ENSTROM F-28/280 SERIES ILLUSTRATED PARTS CATALOG

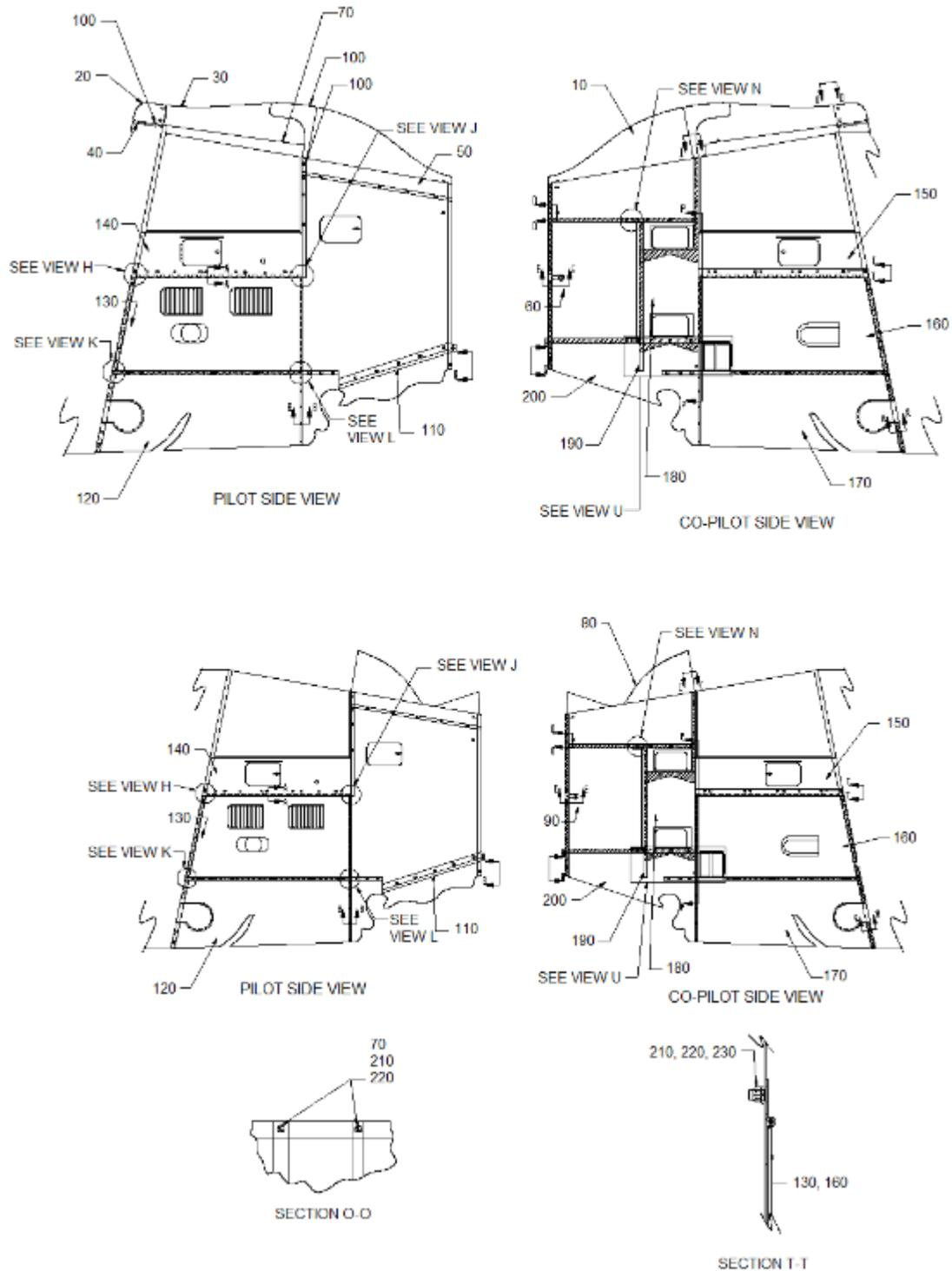
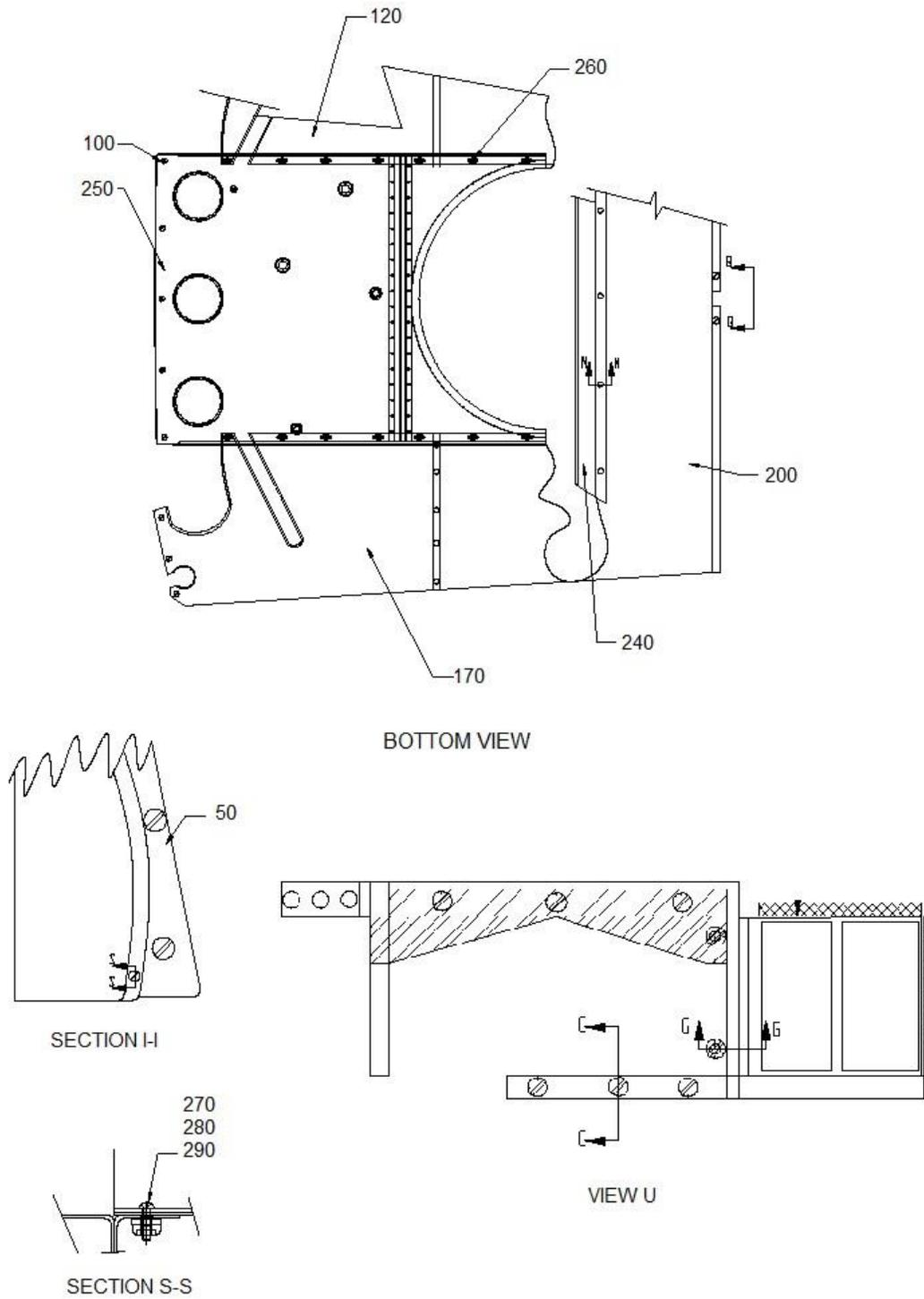

FIGURE 7-10. COWLING (F-28F, 280FX)

ENSTROM F-28/280 SERIES ILLUSTRATED PARTS CATALOG



Sheet 2 of 4

FIGURE 7-10. COWLING (F-28F, 280FX)

ENSTROM F-28/280 SERIES ILLUSTRATED PARTS CATALOG

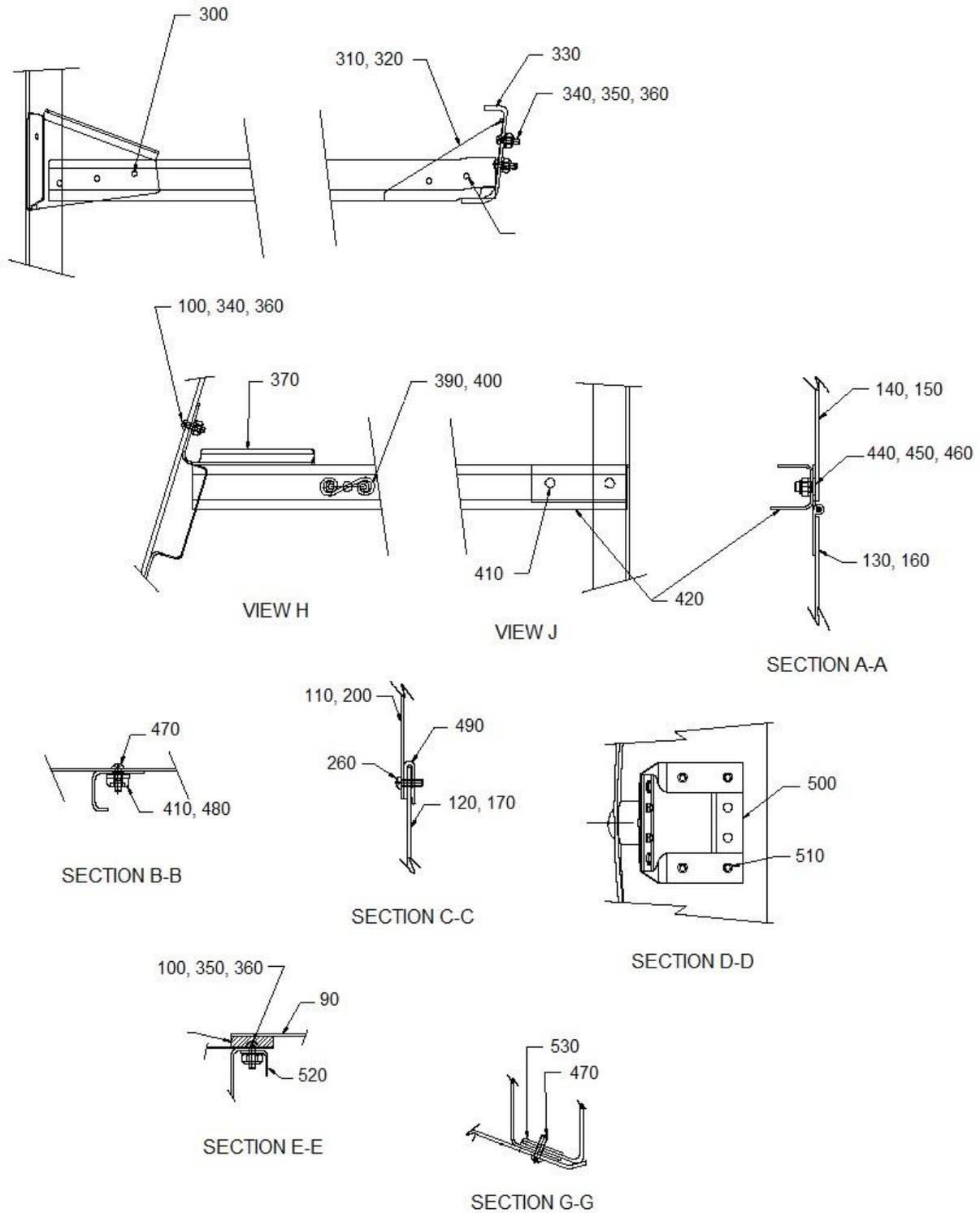

Sheet 3 of 4

FIGURE 7-10. COWLING (F-28F, 280FX)

ENSTROM F-28/280 SERIES ILLUSTRATED PARTS CATALOG

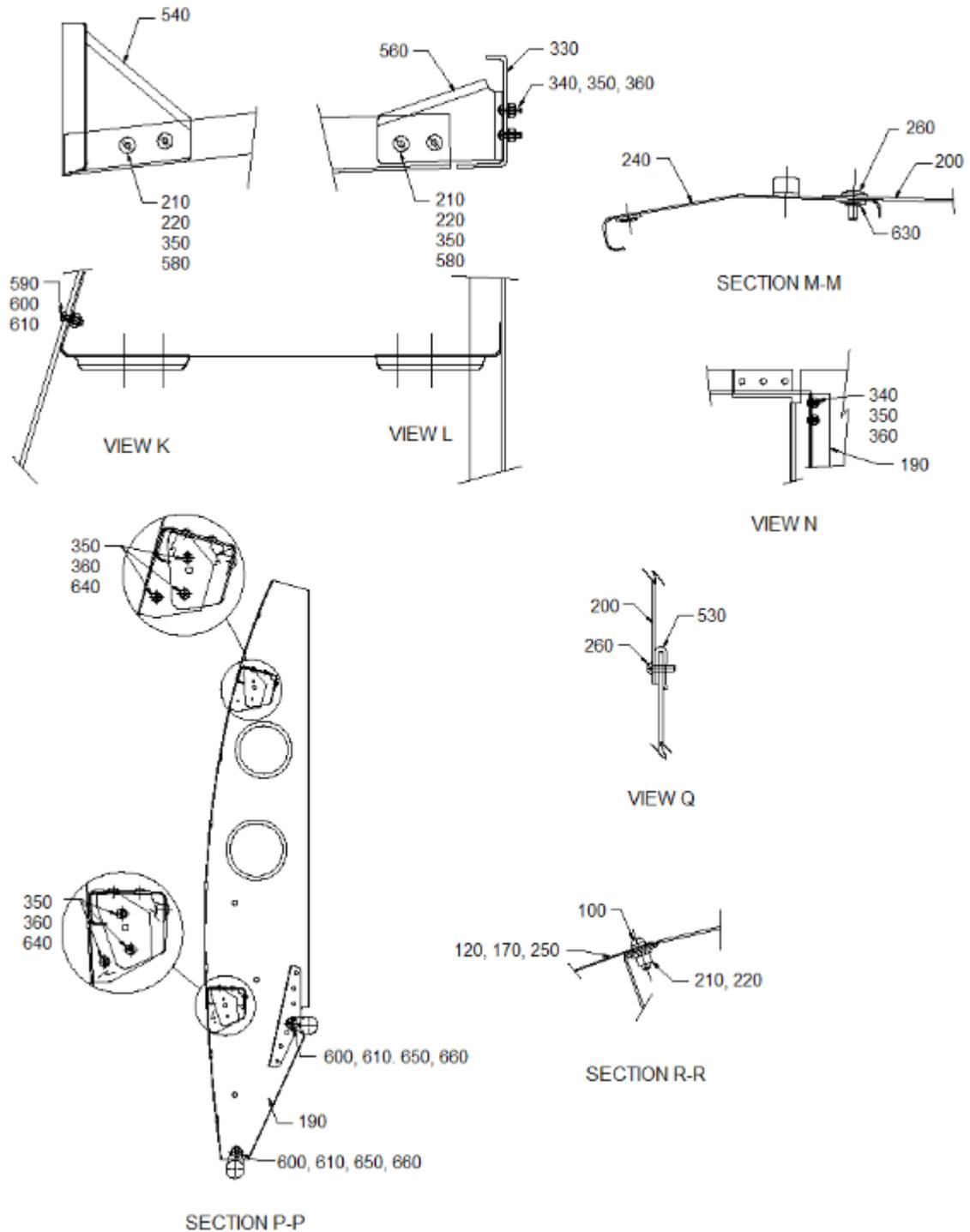

FIGURE 7-10. COWLING (F-28F, 280FX)

ENSTROM F-28/280 SERIES ILLUSTRATED PARTS CATALOG

FIGURE 7-10. COWLING (F-28F, 280FX)

ITEM NUMBER	PART NUMBER	DESCRIPTION	QTY PER ASSY	MODELS AFFECTED						
				F-28A	280	F-28C	280C	F-28F	280F	280FX
—*	28-114014-5	Cowl Installation	REF							X
10	28-114019-3	. Top Cowl & Air Scoop Assembly	1							X
20	28-114023-11	. Airscoop	1							X
30	28-114024-1	. Airduct	1							X
40	28-114026-3	. Nutplate Assembly	1							X
50	28-114022-1	. Panel Assembly	1							X
60	280-114507-3	. Baggage Door Assembly	1							X
70	AN525-832R10	. Screw	4							X
—**	28-114014-9	Cowl Installation	REF					X		
80	28-114019-5	. Top Cowl & Air Scoop Assembly	1					X		
90	280-114507-1	. Baggage Door Assembly	1					X		
100▲	AN525-832R8	. Screw	15					X		X
110	28-114011-5	. Side Cowl Assembly	1					X		X
120	28-114015-1	. Bottom Left Side Cowling Assembly	1					X		X
130	28-114017-1	. Left Side Cowl Assembly	1					X		X
140	280-114502-3	. Left Upper Panel Assembly	1					X		X
150	280-114502-4	. Right Upper Panel Assembly	1					X		X
160	28-114018-1	. Right Side Cowl Assembly	1					X		X
170	28-114015-2	. Bottom Right Side Cowling Assembly	1					X		X
180	28-114013-3	. Step Panel Assembly	1					X		X
190	280-114505-2	. Step Assembly	1					X		X
200	28-114012-1	. Cowl, Lower Panel Assembly	1					X		X
210◆	MS35333-40	. Lock Washer	21					X		X
220◆◇	S8P-150	. Plus Nut	21					X		X
230	MS24693-S51	. Screw	2					X		X
240	280-114508-1	. Aft Cowl Support Assembly	1					X		X
250	28-114016-7	. Center Skin Lower Assembly	1					X		X
260	8 X 1/2	. Screw	41					X		X

ENSTROM F-28/280 SERIES ILLUSTRATED PARTS CATALOG

FIGURE 7-10. COWLING (F-28F, 280FX)

ITEM NUMBER	PART NUMBER	DESCRIPTION	QTY PER ASSY	MODELS AFFECTED						
				F-28A	280	F-28C	280C	F-28F	280F	280FX
270	AN520-832R8	. Screw	2					X		X
280	MS20426AD3-5	. Rivet	2					X		X
290	MS21080-08K	. Nutplate	1					X		X
300	MS20470AD4-3	. Rivet	10					X		X
310	28-11413-5	. Left Aft Attaching Bracket	1					X		X
-320	28-11413-6	. Right Aft Attaching Bracket	1					X		X
330	28-11460-1	. Aft Cowl Ring Assembly and Installation	1					X		X
340	MS35206-244	. Screw	12					X		X
350	NAS1149FN816P	. Washer	44					X		X
360	MS21044N08	. Nut	22					X		X
370	280-114500-19	. Clip	1					X		X
-380	280-114500-20	. Clip	1					X		X
390	1219-4200-Z3Y	. Spring	8					X		X
400‡	MS20426A3-4	. Rivet	16					X		X
410	MS20426AD3-4	. Rivet	16					X		X
420	280-114500-17	. Channel	1					X		X
-430	280-114500-18	. Channel	1					X		X
440	MS24693-S25	. Screw	12					X		X
450	NAS1149FN616P	. Washer	1					X		X
460	MS21044N06	. Nut	12					X		X
470	8 X 1/2	. Screw	41					X		X
480	A06191-8Z-1D	. Tinnerman Nut	6					X		X
490	A01787-8Z-1D	. Tinnerman Nut	6					X		X
500	280-114501-5	. Vibration Mount Assembly	5					X		X
510	MS20470AD4-3.5	. Rivet	20					X		X
520	280-114500-13	. Catch	1					X		X
530	A01789-8Z-1D	. Tinnerman Nut	6					X		X
540	280-114500-21	. Bracket	1					X		X

ENSTROM F-28/280 SERIES ILLUSTRATED PARTS CATALOG

FIGURE 7-10. COWLING (F-28F, 280FX)

ITEM NUMBER	PART NUMBER	DESCRIPTION	QTY PER ASSY	MODELS AFFECTED						
				F-28A	280	F-28C	280C	F-28F	280F	280FX
-550	280-114500-22	. Bracket	1					X		X
560	280-114500-23	. Bracket	1					X		X
-570	280-114500-24	. Bracket	1					X		X
580	MS35206-246	. Screw	8					X		X
590	AN525-10R8	. Screw	2					X		X
600	NAS1149F0332P	. Washer	6					X		X
610	MS21044N3	. Nut	6					X		X
-620	AN3-6A	. Bolt	2					X		X
630	A06195-8Z-1D	. Tinnerman Nut	9					X		X
640	MS35206-245	. Screw	6					X		X
650	AN3-4A	. Bolt	2					X		X
660	NAS1149F0363P	. Washer	2					X		X

* Effectivity 280FX S/N 2172 and subsequent; eligibility 280FX S/N 2001 and subsequent.

** Effectivity F-28F S/N 833 and subsequent; eligibility F-28F S/N 509 and subsequent.

▲ Install 13 additional screws into 28-114014-5.

◆ Install 2 additional lock washers and plus nuts into 28-114014-5.

‡ CRR264SS-3-02 rivet with NAS1149FN316P washer is an acceptable alternate.

◇ In Section R-R and T-T, S8P-270 is an acceptable alternate to S8P-150.

ENSTROM F-28/280 SERIES ILLUSTRATED PARTS CATALOG

|

INTENTIONALLY LEFT BLANK

ENSTROM F-28/280 SERIES ILLUSTRATED PARTS CATALOG

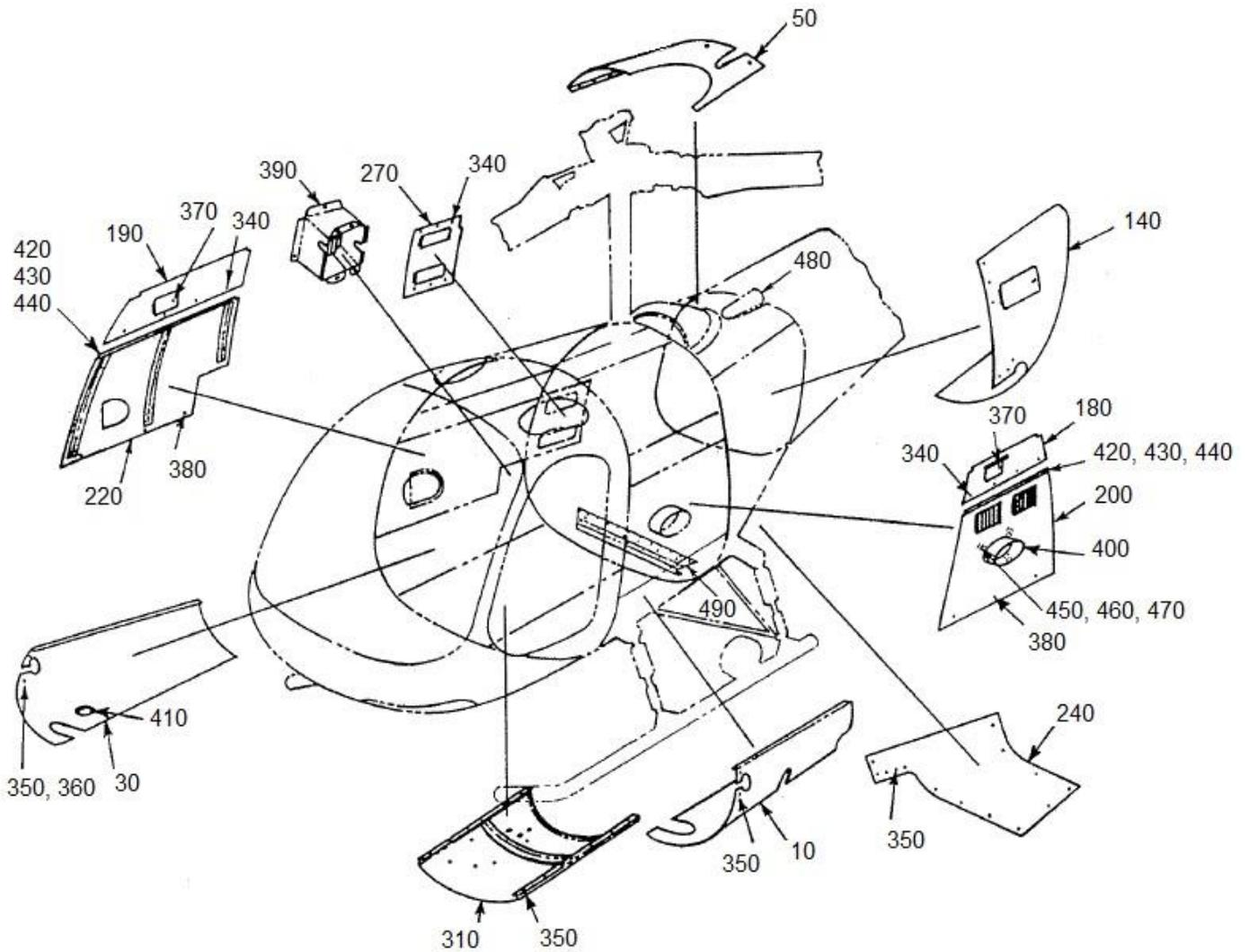

FIGURE 7-11. ENGINE COMPARTMENT ENCLOSURES

ENSTROM F-28/280 SERIES ILLUSTRATED PARTS CATALOG

FIGURE 7-11. ENGINE COMPARTMENT ENCLOSURES

ITEM NUMBER	PART NUMBER	DESCRIPTION	QTY PER ASSY	MODELS AFFECTED						
				F-28A	280	F-28C	280C	F-28F	280F	280FX
-	28-114014-1	Cowl Installation	REF			X	X	X	X	
-*	28-114014-3	Cowl Installation	REF							X
-◇	28-114014-5	Cowl Installation	REF							X
-‡	28-114014-7	Cowl Installation	REF					X		
-▲	28-114014-9	Cowl Installation	REF					X		
10	28-114015-1	. Bottom Left Side Cowling Assembly	1			X	X	X	X	X
-20	280-114503-3	. Bottom Left Side Cowling	1		X					
30	28-114015-2	. Bottom Right Side Cowling Assembly	1			X	X	X	X	X
-40	280-114503-4	. Bottom Right Side Cowling	1		X					
50	28-114010-11	. Top Skin	1			X	X	X	X	
-60	28-114010-12	. Channel	1		X	X	X	X	X	
-70	28-114501-1	. Top Skin	1		X					
-80	28-114509	. Air Scoop	1		X					
-90	28-11401-3	. Air Scoop	1			X	X	X	X	
-100	28-114019-3	. Top Cowl and Air Scoop Assembly	1							X
-110	28-114019-11	. . Top Skin	1							X
-120	28-114025-1	. . Air Scoop Aft	1							X
-130	28-114019-13	. . Channel	1							X
140	28-114011-5	. Side Cowl Assembly	1					X		X
-150	28-114011-17	. . Side Cowl	1		X	X	X	X	X	X
-160	28-114011-13	. . Stiffener	1			X	X	X	X	X
-170	28-114011-15	. Aft Side Cowl	1							X
180●	280-114502-3	. Left Upper Panel Assembly	1		X	X	X	X	X	X
190●	280-114502-4	. Right Upper Panel Assembly	1		X	X	X	X	X	X
200	28-114017-1	. Left Side Cowl Assembly	1			X	X	X	X	X
-210	280-114502-1	. Left Side Cowl Assembly	1		X					
220	28-114018-1	. Right Side Cowl Assembly	1			X	X	X	X	X
-230	28-114002-3	. Right Side Cowl Assembly	1		X					

ENSTROM F-28/280 SERIES ILLUSTRATED PARTS CATALOG

FIGURE 7-11. ENGINE COMPARTMENT ENCLOSURES

ITEM NUMBER	PART NUMBER	DESCRIPTION	QTY PER ASSY	MODELS AFFECTED						
				F-28A	280	F-28C	280C	F-28F	280F	280FX
240●	28-114012-11	. Lower Panel Cowl	1			X	X	X	X	X
-250	280-114503-5	. Aft Bottom Cowl, L/H	1		X					
-260	280-114503-6	. Aft Bottom Cowl, R/H	1		X					
270	28-114013-3	. Step Panel Assembly	1		X	X	X	X	X	X
-280	28-114013-17	. . Step Panel	1		X	X	X	X	X	X
-280	28-114013-11	. . Step Panel (Replaced by 28-114013-17)	1		X	X	X	X	X	X
-290	28-114013-12	. . Shim	2		X	X	X	X	X	X
-300	28-114013-13	. . Door	2		X	X	X	X	X	X
310	28-114016-7	. Center Skin Lower Assembly	1			X	X	X	X	X
310	28-114016-1	. Lower Center Cowl (Replaced by 28-14016-7)	1			X	X	X	X	X
-320	28-114016-3	. Bottom Center Cowl	1					X		
-330	280-114503-1	. Bottom Center Cowl	1		X					
340	82-11-120-16	. Stud	A/R			X	X	X	X	X
350	NK-525-8R8	. Screw	A/R			X	X	X	X	X
360	1/2 X 8R	. Screw	A/R			X	X	X	X	X
370	82-12-120-16	. Stud	A/R			X	X	X	X	X
380	85-140-16	. Stud	A/R			X	X	X	X	X
390	280-126003-1	. Duct Assembly - Exit Oil Cooler	1		X	X	X	X	X	X
400	28-114003-3	. Exhaust Outlet Shield Assembly	1		X	X	X	X	X	X
400	28-114003-1	. Exhaust Outlet Shield Assembly (Replaced by 28-114003-3)	1		X	X	X	X	X	X
410△	GS-3	. Grommet	A/R			X	X	X	X	X
420	MS24693-S25	. Screw	A/R			X	X	X	X	X
420	AN507-632R5	. Screw (Superseded by MS24693-S25)	A/R			X	X	X	X	X
430	AN960PD6L	. Washer	A/R			X	X	X	X	X
440	MS21083N06	. Lock Nut	A/R			X	X	X	X	X
440	AN364-632A	. Lock Nut (Superseded by MS21083N06)	A/R			X	X	X	X	X
450	MS27039-0807	. Screw	3			X	X	X	X	X

ENSTROM F-28/280 SERIES ILLUSTRATED PARTS CATALOG

FIGURE 7-11. ENGINE COMPARTMENT ENCLOSURES

ITEM NUMBER	PART NUMBER	DESCRIPTION	QTY PER ASSY	MODELS AFFECTED						
				F-28A	280	F-28C	280C	F-28F	280F	280FX
450	AN525-832R7	. Screw (Superseded by MS27039-0807)	3			X	X	X	X	X
460	NAS1149FN816P	. Washer	3			X	X	X	X	X
460	AN960-8L	. Washer (Alternate)	3			X	X	X	X	X
470	MS21083N08	. Lock Nut	3			X	X	X	X	X
470	AN364-832A	. Lock Nut (Superseded by MS21083N08)	3			X	X	X	X	X
480	28-11402-1	. Tail Rotor Shaft Fairing	1		X	X	X	X	X	
490	280-114508-1	. Support Lower Cowl	1		X	X	X	X	X	X
490	280-114508-11	. Support Lower Cowl (Replaced by 280-114508-1)	1		X	X	X	X	X	X

* Effectivity 280FX S/N 2001.

◇ Effectivity 280FX S/N 2172 and subsequent. Eligibility 280FX S/N 2001 and subsequent.

‡ Effectivity F-28F S/N 745 and subsequent.

▲ Effectivity F-28F S/N 833 and subsequent. Eligibility F-28F S/N 509 and subsequent.

● Used on F-28C-2 models.

△ Used on late model aircraft with relocated fuel strainer.

ENSTROM F-28/280 SERIES ILLUSTRATED PARTS CATALOG

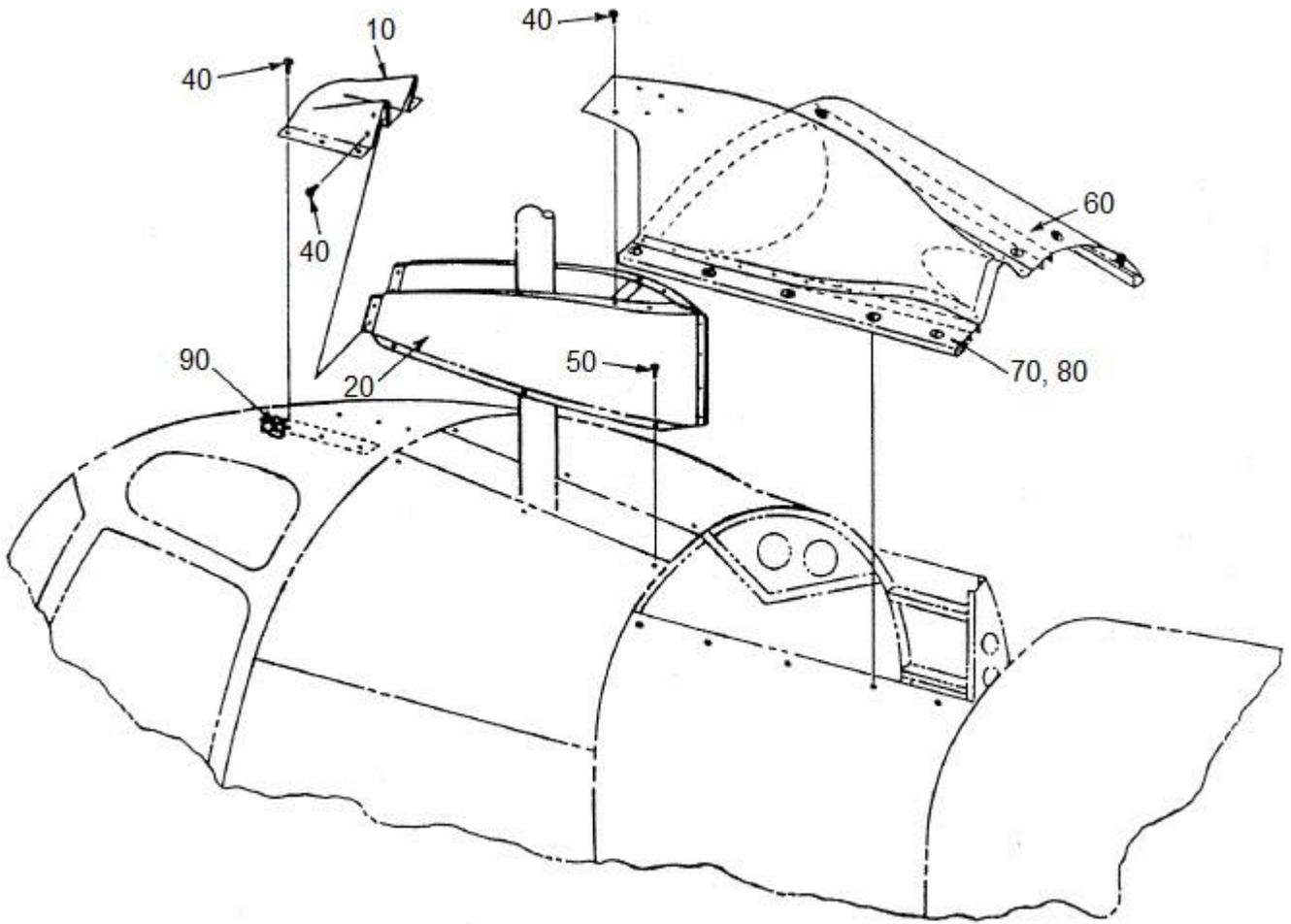

FIGURE 7-12. THREE-PIECE AIRSCOOP

ENSTROM F-28/280 SERIES ILLUSTRATED PARTS CATALOG

FIGURE 7-12. THREE-PIECE AIRSCOOP

ITEM NUMBER	PART NUMBER	DESCRIPTION	QTY PER ASSY	MODELS AFFECTED						
				F-28A	280	F-28C	280C	F-28F	280F	280FX
–	28-114014-5	Cowl Installation	REF							X
10	28-114023-11	. Airscoop	1							X
–	28-114024-1	. Airduct	1							X
20	28-114024-11	. . Center Airduct Panel, L/H	1							X
–30	28-114024-12	. . Center Airduct Panel, R/H	1							X
40	AN525-832R8	. Screw	19							X
40	AN526-832R8	. Screw (Superseded by AN525-832R8)	19							X
50	AN525-832R10	. Screw	4							X
50	AN526-832R10	. Screw (Superseded by AN525-832R10)	4							X
60**	28-114022-1	. Panel Assembly, R/H	1							X
–	28-114019-3	. Top Cowl & Air Scoop Assembly	1							X
70*	28-114019-15	. . Cowling Top	1							X
80**	28-114019-11	. . Top Panel	1							X
90	28-114026-3	. Nutplate Assembly	2							X

* Effectivity 280FX S/N 2005 and subsequent.

** Effectivity 280FX S/N 2001 through 2004.

ENSTROM F-28/280 SERIES ILLUSTRATED PARTS CATALOG

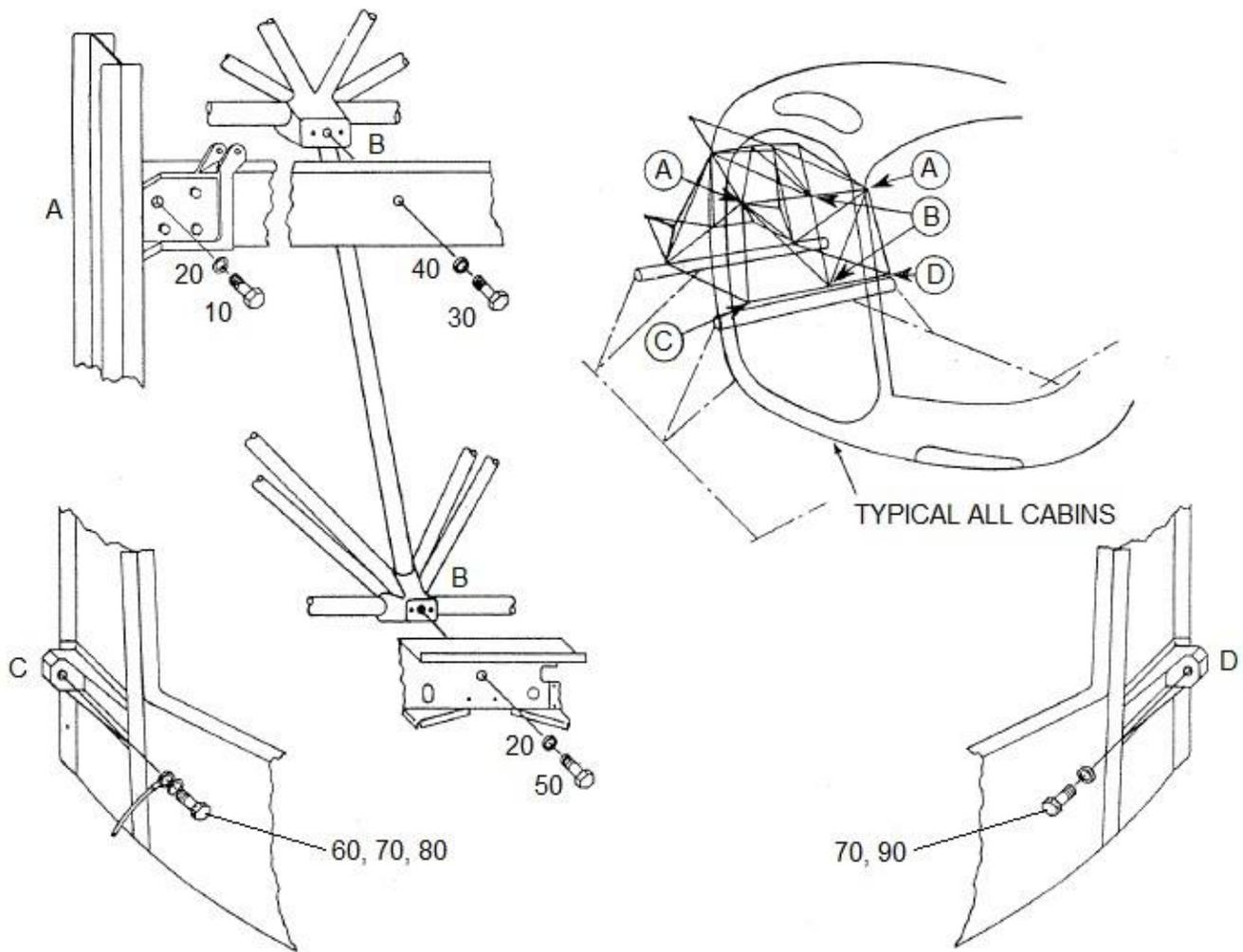

Sheet 1 of 2

FIGURE 7-13. CABIN INSTALLATION AND PYLON AND TAILCONE ASSEMBLY

ENSTROM F-28/280 SERIES ILLUSTRATED PARTS CATALOG

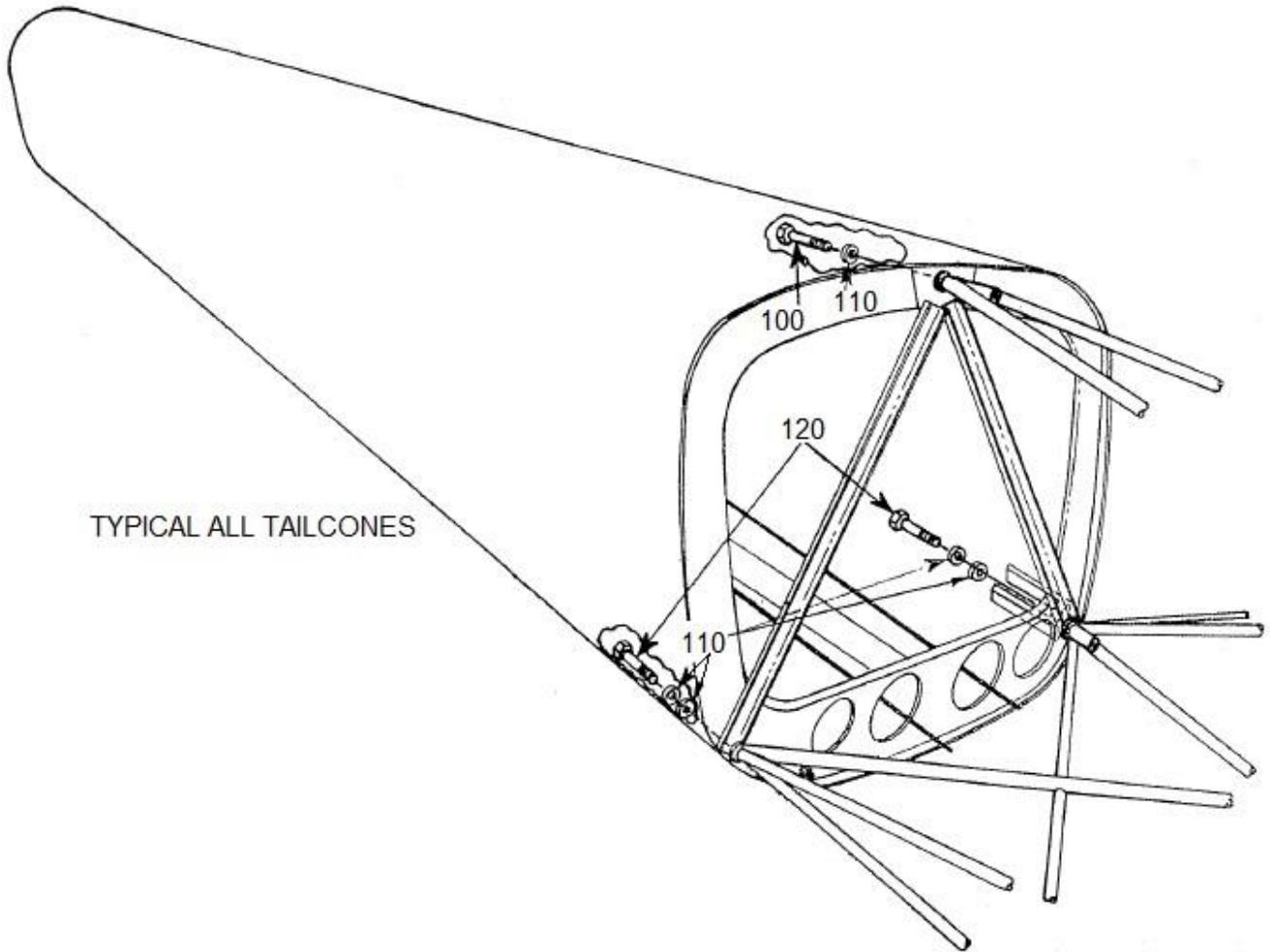

TYPICAL ALL TAILCONES

Sheet 2 of 2

FIGURE 7-13. CABIN INSTALLATION AND PYLON AND TAILCONE ASSEMBLY

ENSTROM F-28/280 SERIES ILLUSTRATED PARTS CATALOG

FIGURE 7-13. CABIN INSTALLATION AND PYLON AND TAILCONE ASSEMBLY

ITEM NUMBER	PART NUMBER	DESCRIPTION	QTY PER ASSY	MODELS AFFECTED						
				F-28A	280	F-28C	280C	F-28F	280F	280FX
-	28-11300	Cabin Installation	REF	X	X	X	X	X	X	X
10	NAS6604-7	. Bolt	2	X	X	X	X	X	X	X
10	AN4-7A	. Bolt (Superseded by NAS6604-7)	2	X	X	X	X	X	X	X
20	NAS1149F0463P	. Washer	3	X	X	X	X	X	X	X
20	AN960-416	. Washer (Alternate)	3	X	X	X	X	X	X	X
30	NAS6604-1	. Bolt	1	X	X	X	X	X	X	X
30	AN4-4A	. Bolt (Superseded by NAS6604-1)	1	X	X	X	X	X	X	X
40	NAS1149F0432P	. Washer	1	X	X	X	X	X	X	X
40	AN960-416L	. Washer (Alternate)	1	X	X	X	X	X	X	X
50	NAS6604-17	. Bolt	1	X	X	X	X	X	X	X
50	AN4-14A	. Bolt (Superseded by NAS6604-17)	1	X	X	X	X	X	X	X
60	NAS6605H9	. Bolt	1	X	X	X	X	X	X	X
60	AN5H10A	. Bolt (Superseded by NAS6605H9)	1	X	X	X	X	X	X	X
70	NAS1149F0563P	. Washer	2	X	X	X	X	X	X	X
70	AN960-516	. Washer (Alternate)	2	X	X	X	X	X	X	X
80	28-19006-24-1	. Wire	1	X	X	X	X	X	X	X
90	NAS6605H7	. Bolt	1	X	X	X	X	X	X	X
90	AN5H7A	. Bolt (Superseded by NAS6605H7)	1	X	X	X	X	X	X	X
-	280-112000-1	Pylon and Tailcone Assembly	REF	X	X	X	X			
-	280-112000-3	Pylon and Tailcone Assembly	REF							X
-	280-112000-5	Pylon and Tailcone Assembly	REF					X	X	X
100	MS20006H14	. Bolt	1	X	X	X	X	X	X	X
100	NAS146DH24	. Bolt (Superseded by MS20006H14)	1	X	X	X	X	X	X	X
110	MS20002-C6	. Washer	5	X	X	X	X	X	X	X
120	MS20006H12	. Bolt	2	X	X	X	X	X	X	X
120	NAS-146-DH-22	. Bolt (Superseded by MS20006H12)	2	X	X	X	X	X	X	X

ENSTROM F-28/280 SERIES ILLUSTRATED PARTS CATALOG

INTENTIONALLY LEFT BLANK

ENSTROM F-28/280 SERIES ILLUSTRATED PARTS CATALOG

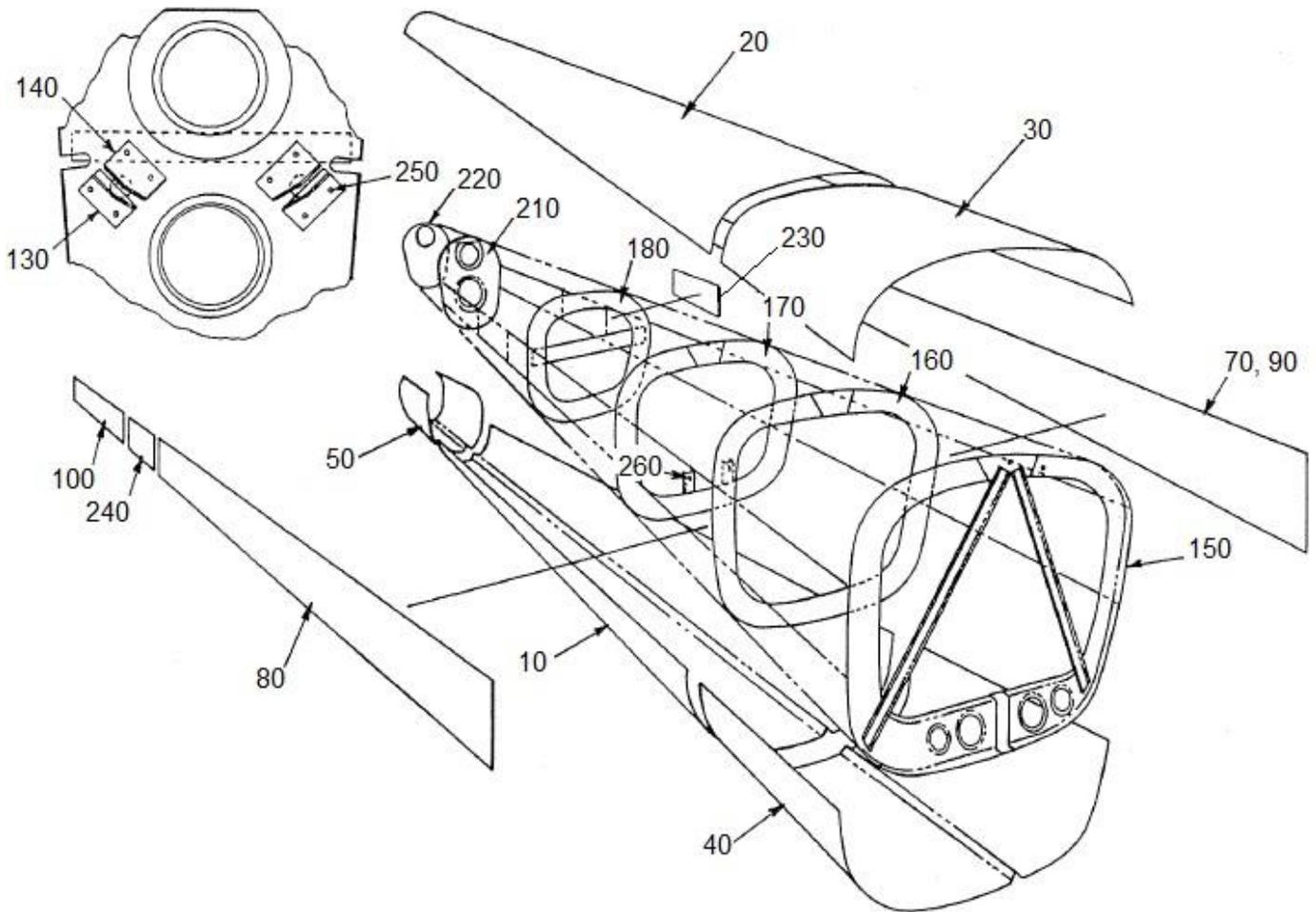

FIGURE 7-14. TAILCONE BULKHEAD AND SKIN ENCLOSURES

ENSTROM F-28/280 SERIES ILLUSTRATED PARTS CATALOG

FIGURE 7-14. TAILCONE BULKHEAD AND SKIN ENCLOSURES

ITEM NUMBER	PART NUMBER	DESCRIPTION	QTY PER ASSY	MODELS AFFECTED						
				F-28A	280	F-28C	280C	F-28F	280F	280FX
-	28-11236-1	Structure Fuselage Tailcone	REF	X	X	X	X	X	X	X
-	28-11236-5	Tailcone Assembly (With Pillow Blocks and Cover Assemblies)	REF							X
-	28-11201-996	. Fuselage Tailcone Skin	1	X	X	X	X	X	X	X
10	28-11201-6	. Skin Bottom Section	1	X	X	X	X	X	X	X
20	28-11201-5	. Skin Top Section	1	X	X	X	X	X	X	X
30	28-11201-3	. Skin Forward Top Section	1	X	X	X	X	X	X	X
40	28-11201-4	. Skin Forward Bottom Section	1	X	X	X	X	X	X	X
50	28-11201-7	. Skin Aft Bottom Section	1	X		X		X		X
-60	280-112001-13	. Skin Bottom Aft	1		X		X		X	
70	280-112001-11	. Skin, L/H Side	1				X		X	
80	280-112001-12	. Skin, RH Side	1				X	X	X	X
90	28-11201-8	. Skin, L/H Panel	1	X		X		X		X
100	28-11201-12	. Skin, R/H Panel	1	X		X		X		
-110	28-11236-31	. Skin, R/H	1					X		
-120	280-112001-15	. Skin, R/H	1		X		X		X	
130	28-11243-11	. Pulley Bracket, R/H	1					X	X	X
140	28-11242-11	. Pulley Bracket, R/H	1					X	X	X
150	28-11202-1	. Bulkhead Assembly	1	X	X	X	X	X	X	X
160	28-11203-1	. Bulkhead Assembly	1	X	X	X	X	X	X	X
170	28-11204-11	. Bulkhead Assembly	1	X	X	X	X	X	X	X
170	28-11204-1	. Bulkhead Assembly (Superseded by 28-11204-11)	1	X	X	X	X	X	X	X
-	28-11248-1	. Bulkhead Assembly	1	X	X	X	X	X	X	X
180	28-11205-11	. Bulkhead #4	1					X		X
180	28-11205-1	. Bulkhead #4 (Replaced by 28-11205-11)	1	X		X		X		
-190	280-112002-1	. Bulkhead	1		X		X		X	
-200	280-112002-3	. Bulkhead Assembly Center Aft	1					X		X
210	28-11206-5	. Bulkhead Assembly	1	X	X	X	X	X	X	X
210	28-11206-1	. Bulkhead Assembly (Superseded by 28-11206-5)	1	X	X	X	X	X	X	X

ENSTROM F-28/280 SERIES ILLUSTRATED PARTS CATALOG

FIGURE 7-14. TAILCONE BULKHEAD AND SKIN ENCLOSURES

ITEM NUMBER	PART NUMBER	DESCRIPTION	QTY PER ASSY	MODELS AFFECTED						
				F-28A	280	F-28C	280C	F-28F	280F	280FX
220	28-11207-3	. Bulkhead	1	X	X	X	X	X	X	X
220	28-11207-1	. Bulkhead (Superseded by 28-11207-3)	1	X	X	X	X	X	X	X
230	28-11225-11	. Access Plate, L/H	1	X	X	X	X	X	X	X
240	280-112006-11	. Access Door	1					X	X	X
250	MS20470AD4-4	. Rivet	8					X	X	X
260	NAS-1368-N8A	. Grommet	2	X	X	X	X	X	X	X

ENSTROM F-28/280 SERIES ILLUSTRATED PARTS CATALOG



INTENTIONALLY LEFT BLANK

ENSTROM F-28/280 SERIES ILLUSTRATED PARTS CATALOG

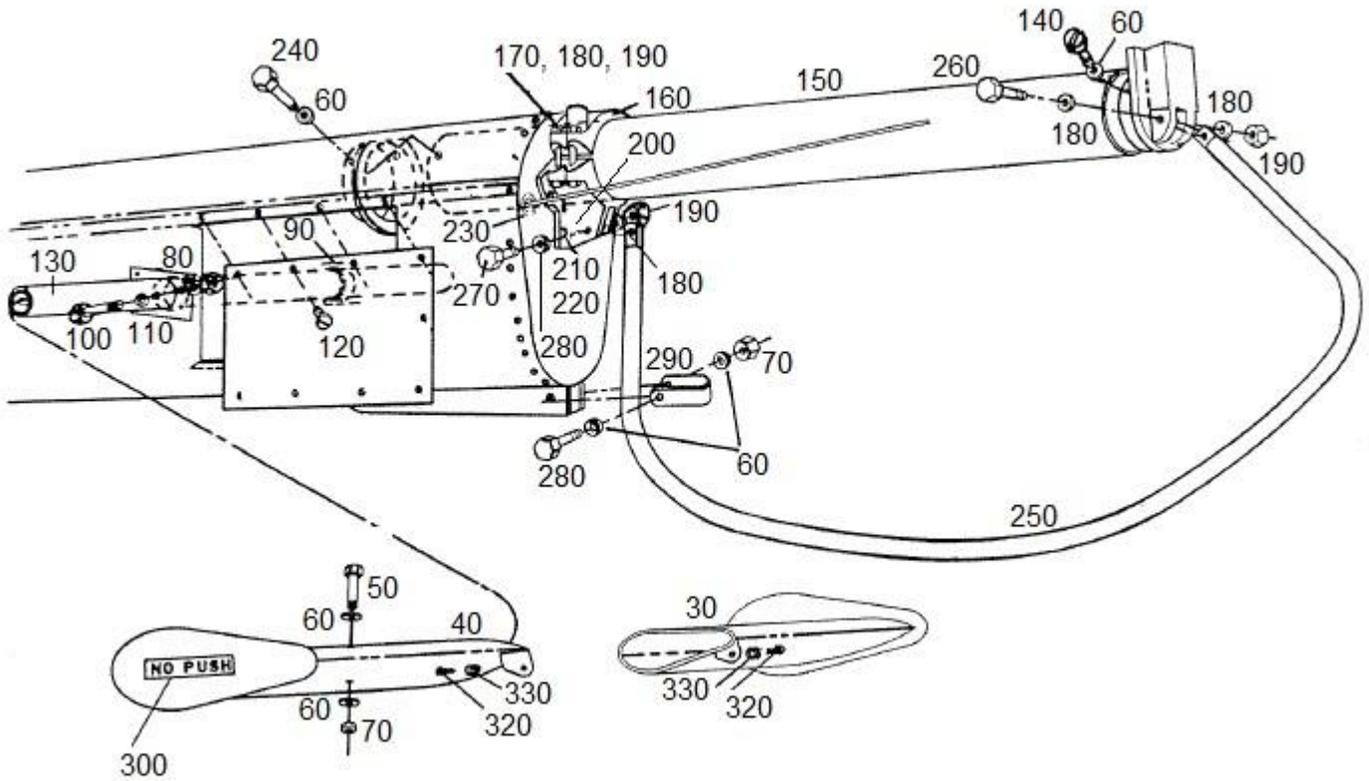

FIGURE 7-15. STABILIZER AND TAILCONE EXTENSION (F-28A, F-28C, F-28F)

ENSTROM F-28/280 SERIES ILLUSTRATED PARTS CATALOG

FIGURE 7-15. STABILIZER AND TAILCONE EXTENSION (F-28A, F-28C, F-28F)

ITEM NUMBER	PART NUMBER	DESCRIPTION	QTY PER ASSY	MODELS AFFECTED						
				F-28A	280	F-28C	280C	F-28F	280F	280FX
-	28-20000	Stabilizer Assembly	REF	X		X		X		
-10	28-20100-1	. Stabilizer Assembly, L/H	1	X						
-20	28-20100-2	. Stabilizer Assembly, R/H	1	X						
30	28-20100-6	. Stabilizer Assembly, R/H	1			X		X		
40	28-20100-7	. Stabilizer Assembly, L/H	1			X		X		
50	NAS6603-26	. Bolt	4	X		X		X		
50	AN3-20A	. Bolt (Superseded by NAS6603-26)	4	X		X		X		
60	NAS1149F0332P	. Washer	11	X		X		X		
60	AN960-10L	. Washer (Alternate)	11	X		X		X		
70	MS21044N3	. Nut	5	X		X		X		
70	AN365-1032A	. Nut (Superseded by MS21044N3)	5	X		X		X		
80	28-11221-1	. Bracket, L/H	1	X		X		X		
90	28-11221-2	. Bracket, R/H	1	X		X		X		
100	NAS6603-24	. Bolt	2	X		X		X		
100	AN3-17A	. Bolt (Superseded by NAS6603-24)	2	X		X		X		
110	NAS1149F0363P	. Washer	12	X		X		X		
110	AN960-10	. Washer (Equivalent)	12	X		X		X		
120	MS27039-0808	. Screw	9	X		X		X		
120	AN525-832R8	. Screw (Superseded by MS27039-0808)	9	X		X		X		
130	28-11222-1	. Stabilizer Spar	1	X		X		X		
140	NAS1101-3-10	. Screw	6	X	X	X	X	X	X	X
140	AN502-10-10	. Screw (Superseded by NAS1101-3-10)	6	X	X	X	X	X	X	X
-	28-11236-1	Structure Assembly Fuselage Tailcone	REF	X	X	X	X	X	X	X
150	28-11218-1	. Stinger Tube	1	X	X	X	X	X	X	X
160	28-11217-3	. Clamp	1	X	X	X	X	X	X	X
160	28-11217-1	. Clamp (Replaced by 28-11217-3)	1	X	X	X	X	X	X	X

ENSTROM F-28/280 SERIES ILLUSTRATED PARTS CATALOG

FIGURE 7-15. STABILIZER AND TAILCONE EXTENSION (F-28A, F-28C, F-28F)

ITEM NUMBER	PART NUMBER	DESCRIPTION	QTY PER ASSY	MODELS AFFECTED						
				F-28A	280	F-28C	280C	F-28F	280F	280FX
170	NAS6604-27	. Bolt	4	X	X	X	X	X	X	X
170	AN4-21A	. Bolt (Superseded by NAS6604-27)	4	X	X	X	X	X	X	X
180	NAS1149F0432P	. Washer	12	X	X	X	X	X	X	X
180	AN960-416L	. Washer (Alternate)	12	X	X	X	X	X	X	X
190	MS21044N4	. Nut	4	X	X	X	X	X	X	X
190	AN365-428A	. Nut (Superseded by MS21044N4)	4	X	X	X	X	X	X	X
200	28-11215-1	. Lower Clamp	1	X	X	X	X	X	X	X
210	MS20470AD4-7	. Rivet	4	X	X	X	X	X	X	X
220	MS20470AD4-6	. Rivet	3	X	X	X	X	X	X	X
230	NAS-1368-N8A	. Grommet	2	X	X	X	X	X	X	X
240	NAS6603-4	. Bolt	3	X	X	X	X	X	X	X
240	AN3-5A	. Bolt (Superseded by NAS6603-4)	3	X	X	X	X	X	X	X
-	28-17200-3	Tail Rotor Guard Installation	REF	X		X		X		X
-	28-17201-1	. Tail Rotor Guard Assembly	1	X		X		X		X
250	28-17202-1	. Tail Rotor Guard Tube	1	X		X		X		X
260	NAS6604-29	. Bolt	1	X		X		X		X
260	AN4-22A	. Bolt (Superseded by NAS6604-29)	1	X		X		X		X
270	NAS6604-25	. Bolt	1	X	X	X	X	X	X	X
270	AN4-20A	. Bolt (Superseded by NAS6604-25)	1	X	X	X	X	X	X	X
280	NAS6603-22	. Bolt	1	X	X	X	X	X	X	X
280	AN3-16A	. Bolt (Superseded by NAS6603-22)	1	X	X	X	X	X	X	X
290	28-17205-1	. Clamp	1	X		X		X		X
300	28-20107-11	. Placard - No Push (Red)	2	X		X		X		X
-310	28-20107-13	. Placard - No Push (White)	2	X		X		X		X
320	AN526-832R8	. Screw	2	X	X	X	X	X	X	X
330	NAS1149FN816P	. Washer	2	X	X	X	X	X	X	X
330	AN960-8L	. Washer (Alternate)	2	X	X	X	X	X	X	X

ENSTROM F-28/280 SERIES ILLUSTRATED PARTS CATALOG



INTENTIONALLY LEFT BLANK

ENSTROM F-28/280 SERIES ILLUSTRATED PARTS CATALOG

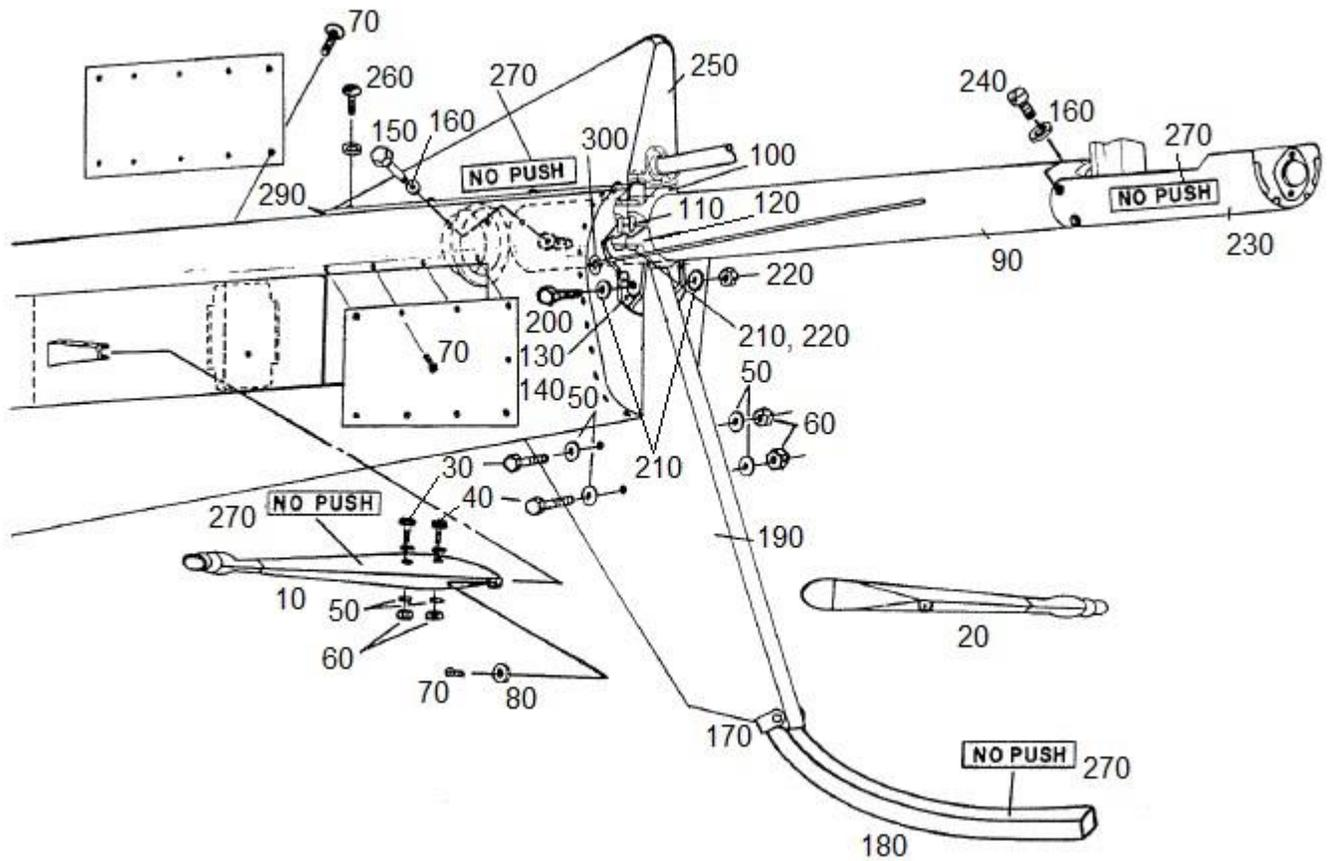

FIGURE 7-16. STABILIZER AND TAILCONE EXTENSION (280, 280C, 280F)

ENSTROM F-28/280 SERIES ILLUSTRATED PARTS CATALOG

FIGURE 7-16. STABILIZER AND TAILCONE EXTENSION (280, 280C, 280F)

ITEM NUMBER	PART NUMBER	DESCRIPTION	QTY PER ASSY	MODELS AFFECTED						
				F-28A	280	F-28C	280C	F-28F	280F	280FX
10	280-200000-1	. Horizontal Stabilizer, L/H	1		X		X		X	
20	280-200000-2	. Horizontal Stabilizer, R/H	1		X		X		X	
30	NAS6603-22	. Bolt	3		X		X		X	
30	AN3-16A	. Bolt (Superseded by NAS6603-22)	3		X		X		X	
40	NAS6603-24	. Bolt	3		X		X		X	
40	AN3-17A	. Bolt (Superseded by NAS6603-24)	3		X		X		X	
50	NAS1149D0316H	. Washer	12		X		X		X	
50	AN960D10L	. Washer (Alternate)	12		X		X		X	
60	MS21044N3	. Nut	6		X		X		X	
60	AN365-1032A	. Nut (Superseded by MS21044N3)	6		X		X		X	
70	AN526-832R8	. Screw	21		X		X		X	
80	NAS1149FN816P	. Washer	10		X		X		X	
80	AN960-8L	. Washer (Alternate)	10		X		X		X	
-	28-11236-1	Structure Assembly Fuselage Tailcone	REF	X	X	X	X	X	X	X
90	28-11218-1	. Extension Tube	1	X	X	X	X	X	X	X
100	28-11217-3	. Clamp	1	X	X	X	X	X	X	X
100	28-11217-1	. Clamp (Replaced by 28-11217-3)	1	X	X	X	X	X	X	X
110	NAS6604-27	. Bolt	4	X	X	X	X	X	X	X
110	AN4-21A	. Bolt (Superseded by NAS6604-27)	4	X	X	X	X	X	X	X
120	28-11215-1	. Clamp	1	X	X	X	X	X	X	X
130	MS20470AD4-7	. Rivet	4	X	X	X	X	X	X	X
140	MS20470AD4-6	. Rivet	3	X	X	X	X	X	X	X
150	NAS6603-4	. Bolt	3	X	X	X	X	X	X	X
150	AN3-5A	. Bolt (Superseded by NAS6603-4)	3	X	X	X	X	X	X	X
160	NAS1149F0332P	. Washer	9	X	X	X	X	X	X	X

ENSTROM F-28/280 SERIES ILLUSTRATED PARTS CATALOG

FIGURE 7-16. STABILIZER AND TAILCONE EXTENSION (280, 280C, 280F)

ITEM NUMBER	PART NUMBER	DESCRIPTION	QTY PER ASSY	MODELS AFFECTED						
				F-28A	280	F-28C	280C	F-28F	280F	280FX
160	AN960-10L	. Washer (Alternate)	9	X	X	X	X	X	X	X
170	280-201000-41	. Strap	1		X		X		X	
180	280-201000-33	. Stinger Tube	1		X		X		X	
190	280-201000-1	. Stabilizer	1		X		X		X	
200	NAS6604-25	. Bolt	1	X	X	X	X	X	X	X
200	AN4-20A	. Bolt (Superseded by NAS6604-25)	1	X	X	X	X	X	X	X
210	NAS1149F0432P	. Washer	10	X	X	X	X	X	X	X
210	AN960-416L	. Washer (Alternate)	10	X	X	X	X	X	X	X
220	MS21044N4	. Nut	5	X	X	X	X	X	X	X
220	AN365-428A	. Nut (Superseded by MS21044N4)	5	X	X	X	X	X	X	X
230	280-210002-1	. Light Support	1		X		X		X	
240	NAS1101-3-10	. Screw	6	X	X	X	X	X	X	X
240	AN502-10-10	. Screw (Superseded by NAS1101-3-10)	6	X	X	X	X	X	X	X
250	280-201002-11	. Stabilizer	1		X		X		X	
260	MS27039-0808	. Screw	8		X		X		X	
260	AN525-832R8	. Screw (Superseded by MS27039-0808)	8		X		X		X	
270	28-20107-11	. Placard - No Push (Red)	7		X		X		X	
-280	28-20107-13	. Placard - No Push (White)	7		X		X		X	
290	4508-1	. Foam Tape	A/R		X		X		X	
300	NAS-1368-N8A	. Grommet	2	X	X	X	X	X	X	X

ENSTROM F-28/280 SERIES ILLUSTRATED PARTS CATALOG

I

INTENTIONALLY LEFT BLANK

ENSTROM F-28/280 SERIES ILLUSTRATED PARTS CATALOG

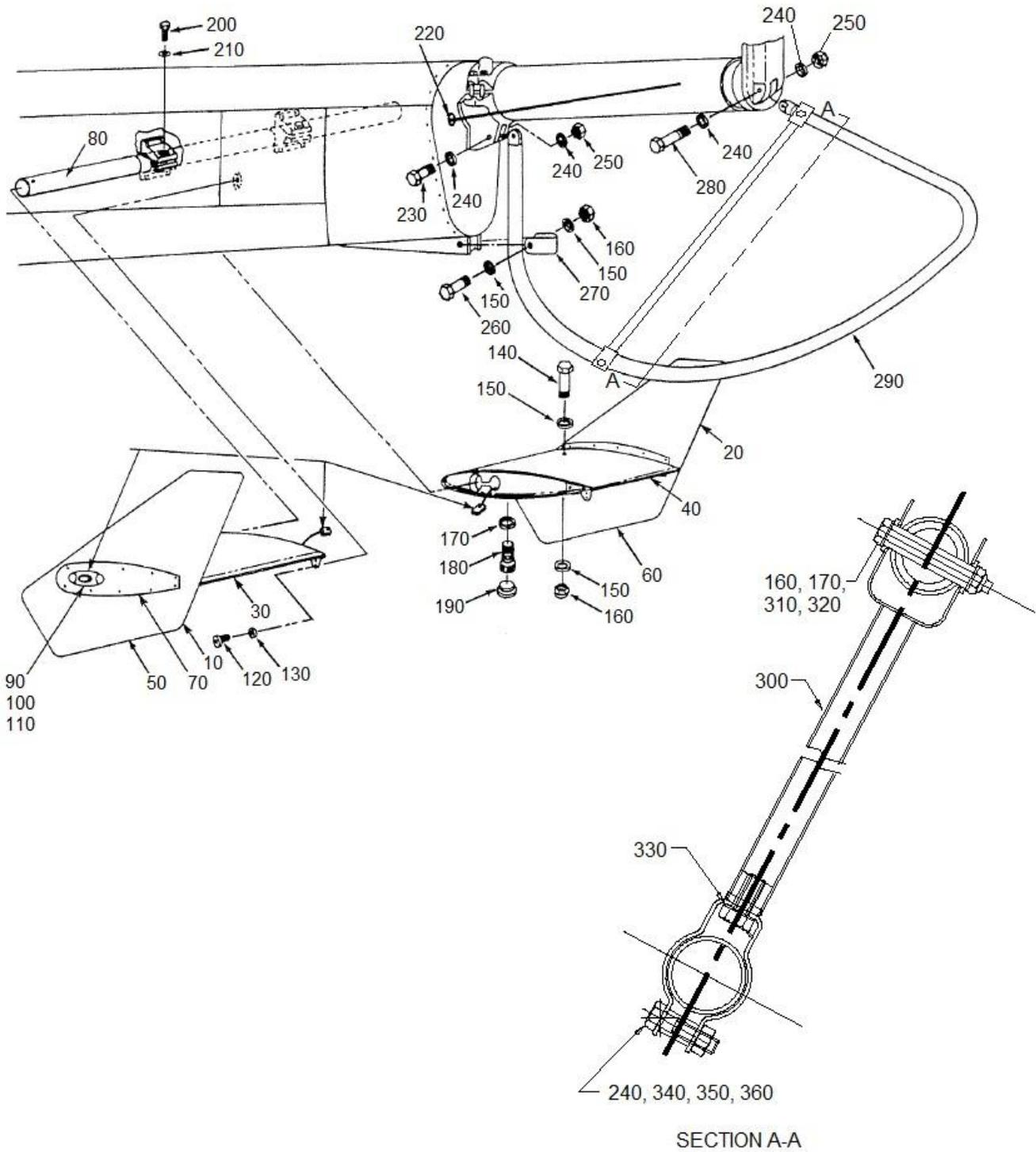

FIGURE 7-17. STABILIZER AND TAILCONE EXTENSION (F-28F, 280FX)

ENSTROM F-28/280 SERIES ILLUSTRATED PARTS CATALOG

FIGURE 7-17. STABILIZER AND TAILCONE EXTENSION (F-28F, 280FX)

ITEM NUMBER	PART NUMBER	DESCRIPTION	QTY PER ASSY	MODELS AFFECTED						
				F-28A	280	F-28C	280C	F-28F	280F	280FX
10	28-20119-3	. Stabilizer Installation, L/H	1					X		X
10	28-20119-1	. Stabilizer Installation, L/H (Superseded by 28-20119-3)	1					X		X
20	28-20119-4	. Stabilizer Installation, R/H	1					X		X
20	28-20119-2	. Stabilizer Installation, R/H (Superseded by 28-20119-4)	1					X		X
30	28-20111-911	. . Horizontal Stabilizer, L/H	1					X		X
30	28-20111-1	. . Horizontal Stabilizer, L/H (Superseded by 28-20111-911)	1					X		X
40	28-20111-912	. . Horizontal Stabilizer, R/H	1					X		X
40	28-20111-2	. . Horizontal Stabilizer, R/H (Superseded by 28-20111-912)	1					X		X
50	28-20112-15	. . Vertical Stabilizer, L/H	1					X		X
50	28-20112-1	. . Vertical Stabilizer, L/H (Superseded by 28-20112-15)	1					X		X
60	28-20112-16	. . Vertical Stabilizer, R/H	1					X		X
60	28-20112-2	. . Vertical Stabilizer, R/H (Superseded by 28-20112-16)	1					X		X
70	28-20116-11	. . Plate	2					X		X
80	28-11222-15	. . Spar	1					X		X
90	AN525-1032R12	. Screw	20					X		X
100	NAS1149D0316J	. Washer	40					X		X
100	AN960PD10L	. Washer (Alternate)	40					X		X
110	MS21083N3	. Nut	20					X		X
110	AN364-1032A	. Nut (Superseded by MS21083N3)	20					X		X
120	AN526-832R8	. Screw	2	X	X	X	X	X	X	X
130	NAS1149FN816P	. Washer	2	X	X	X	X	X	X	X
130	AN960-8L	. Washer (Alternate)	2	X	X	X	X	X	X	X
140	NAS6603-26	. . Bolt	2					X		X
140	AN3-20A	. . Bolt (Superseded by NAS6603-26)	2					X		X
150	NAS1149F0332P	. . Washer	6					X		X

ENSTROM F-28/280 SERIES ILLUSTRATED PARTS CATALOG

FIGURE 7-17. STABILIZER AND TAILCONE EXTENSION (F-28F, 280FX)

ITEM NUMBER	PART NUMBER	DESCRIPTION	QTY PER ASSY	MODELS AFFECTED						
				F-28A	280	F-28C	280C	F-28F	280F	280FX
150	AN960-10L	. . Washer (Alternate)	6					X		X
160	MS21044N3	. . Locknut	3					X		X
160	AN365-1032A	. . Locknut (Superseded by MS21044N3)	3					X		X
170	NAS1149F0463P	. . Washer	4					X		X
170	AN960-10	. . Washer (Replaced by NAS1149F0463P)	4					X		X
180	MS16998-44	. . Cap Screw	4					X		X
190	BPF-1/2	. . Cap Plug	4					X		X
200	NK4-7A	. Bolt	2					X		X
210	NAS1149D0463J	. Washer	2					X		X
210	AN960PD416	. Washer (Alternate)	2					X		X
-	28-17200-3	Tail Rotor Guard Installation	REF					X		X
220	NAS-1368-N8A	. Grommet	2	X		X		X		X
230	NAS6604-25	. Bolt	1	X		X		X		X
230	AN4-20A	. Bolt (Superseded by NAS6604-25)	1	X		X		X		X
240	NAS1149F0432P	. Washer	4	X		X		X		X
240	AN960-416L	. Washer (Alternate)	4	X		X		X		X
250	MS21044N4	. Nut	2	X		X		X		X
250	AN365-428A	. Nut (Superseded by MS21044N4)	2	X		X		X		X
260	NAS6603-22	. Bolt	1	X		X		X		X
260	AN3-16A	. Bolt (Superseded by NAS6603-22)	1	X		X		X		X
270	28-17205-1	. Clamp	1	X		X		X		X
-	28-17206-13	. Pad	A/R	X		X		X		X
280	NAS6604-29	. Bolt	1	X		X		X		X
280	AN4-22A	. Bolt (Superseded by NAS6604-29)	1	X		X		X		X
290	28-17201-3	. Tail Rotor Guard	1	X		X		X		X
300	28-17207-1	. Strut Assembly	1	X		X		X		X

ENSTROM F-28/280 SERIES ILLUSTRATED PARTS CATALOG

FIGURE 7-17. STABILIZER AND TAILCONE EXTENSION (F-28F, 280FX)

ITEM NUMBER	PART NUMBER	DESCRIPTION	QTY PER ASSY	MODELS AFFECTED						
				F-28A	280	F-28C	280C	F-28F	280F	280FX
310	NAS6603-24	. Bolt	1	X		X		X		X
310	AN3-17A	. Bolt (Superseded by NAS6603-24)	1	X		X		X		X
320	NAS73-3-108	. Bushing	1	X		X		X		X
330	28-17206-11	. Spacer	A/R	X		X		X		X
340	NAS6604-11	. Bolt	1	X		X		X		X
340	AN4-11A	. Bolt (Superseded by NAS6604-11)	1	X		X		X		X
350	28-17206-17	. Spacer	1	X		X		X		X
360	MS21083N4	. Nut	1	X		X		X		X
360	AN364-428A	. Nut (Superseded by MS21083N4)	1	X		X		X		X

ENSTROM F-28/280 SERIES ILLUSTRATED PARTS CATALOG

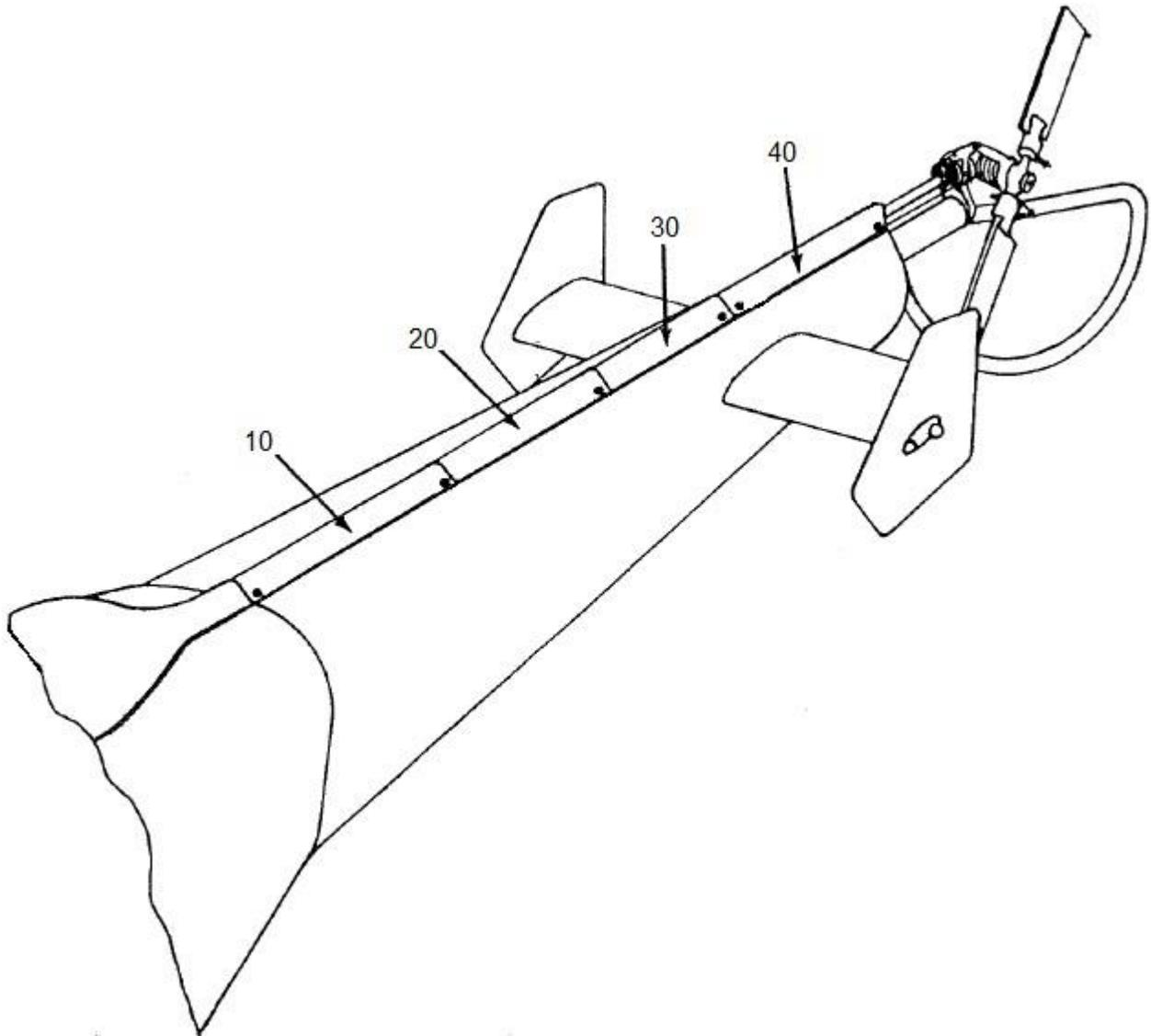

FIGURE 7-18. TAIL ROTOR DRIVE SHAFT COVER

ENSTROM F-28/280 SERIES ILLUSTRATED PARTS CATALOG

FIGURE 7-18. TAIL ROTOR DRIVE SHAFT COVER

ITEM NUMBER	PART NUMBER	DESCRIPTION	QTY PER ASSY	MODELS AFFECTED						
				F-28A	280	F-28C	280C	F-28F	280F	280FX
-	28-11236-5	Tailcone Assembly	REF							X
10	28-11239-1	. Cover Assembly - Shaft Tail Rotor	1							X
-	28-11239-11	.. Cover	1							X
-	82-19-160-16	.. Oval Head Screw	2							X
-	43-13-1-24	.. Spring Ejector	2							X
-	82-46-101-39	.. Wear Washer	2							X
-	82-32-101-20	.. Retainer	2							X
-	28-11239-27	.. Doubler	1							X
-	28-11239-35	.. Doubler	1							X
-	28-11239-37	.. Doubler	1							X
-	28-11227-13	.. Hinge	1							X
-	28-11227-17	.. Hinge	1							X
-	MS20426A3-3	.. Rivet	2							X
-	MS20426A3-4	.. Rivet	6							X
20	28-11239-3	. Cover Assembly - Shaft Tail Rotor	1							X
-	28-11239-13	.. Cover	1							X
-	82-19-160-16	.. Oval Head Screw	2							X
-	43-13-1-24	.. Spring Ejector	1							X
-	82-46-101-39	.. Wear Washer	1							X
-	82-32-101-20	.. Retainer	1							X
-	28-11239-37	.. Doubler	1							X
-	28-11239-39	.. Doubler	1							X
-	28-11239-21	.. Extension	1							X
-	28-11227-17	.. Hinge	1							X
-	28-11227-21	.. Hinge	1							X
-	MS20426A3-3	.. Rivet	4							X
-	MS20426A3-4	.. Rivet	4							X
-	5451	.. Teflon Tape	A/R							X

ENSTROM F-28/280 SERIES ILLUSTRATED PARTS CATALOG

FIGURE 7-18. TAIL ROTOR DRIVE SHAFT COVER

ITEM NUMBER	PART NUMBER	DESCRIPTION	QTY PER ASSY	MODELS AFFECTED						
				F-28A	280	F-28C	280C	F-28F	280F	280FX
30	28-11239-9	. Cover Assembly - Shaft Tail Rotor	1							X
-	28-11239-23	. . Cover	1							X
-	82-19-160-16	. . Oval Head Screw	1							X
-	43-13-1-24	. . Spring Ejector	1							X
-	82-46-101-39	. . Wear Washer	1							X
-	82-32-101-20	. . Retainer	1							X
-	28-11239-27	. . Doubler	1							X
-	28-11239-35	. . Doubler	1							X
-	28-11239-39	. . Doubler	1							X
-	28-11239-21	. . Extension	1							X
-	28-11227-13	. . Hinge	1							X
-	28-11227-21	. . Hinge	1							X
-	MS20426A3-3	. . Rivet	6							X
-	MS20426A3-4	. . Rivet	6							X
-	5451	. . Teflon Tape	A/R							X
40	28-11239-101	. Cover Assembly - Shaft Tail Rotor	1							X
-	28-11239-25	. . Cover	1							X
-	82-19-160-16	. . Oval Head Screw	2							X
-	43-13-1-24	. . Spring Ejector	2							X
-	82-46-101-39	. . Wear Washer	2							X
-	82-32-101-20	. . Retainer	2							X
-	28-11239-19	. . Extension	1							X
-	MS20426A3-3	. . Rivet	8							X
-	5451	. . Teflon Tape	A/R							X

ENSTROM F-28/280 SERIES ILLUSTRATED PARTS CATALOG

|

INTENTIONALLY LEFT BLANK

ENSTROM F-28/280 SERIES ILLUSTRATED PARTS CATALOG

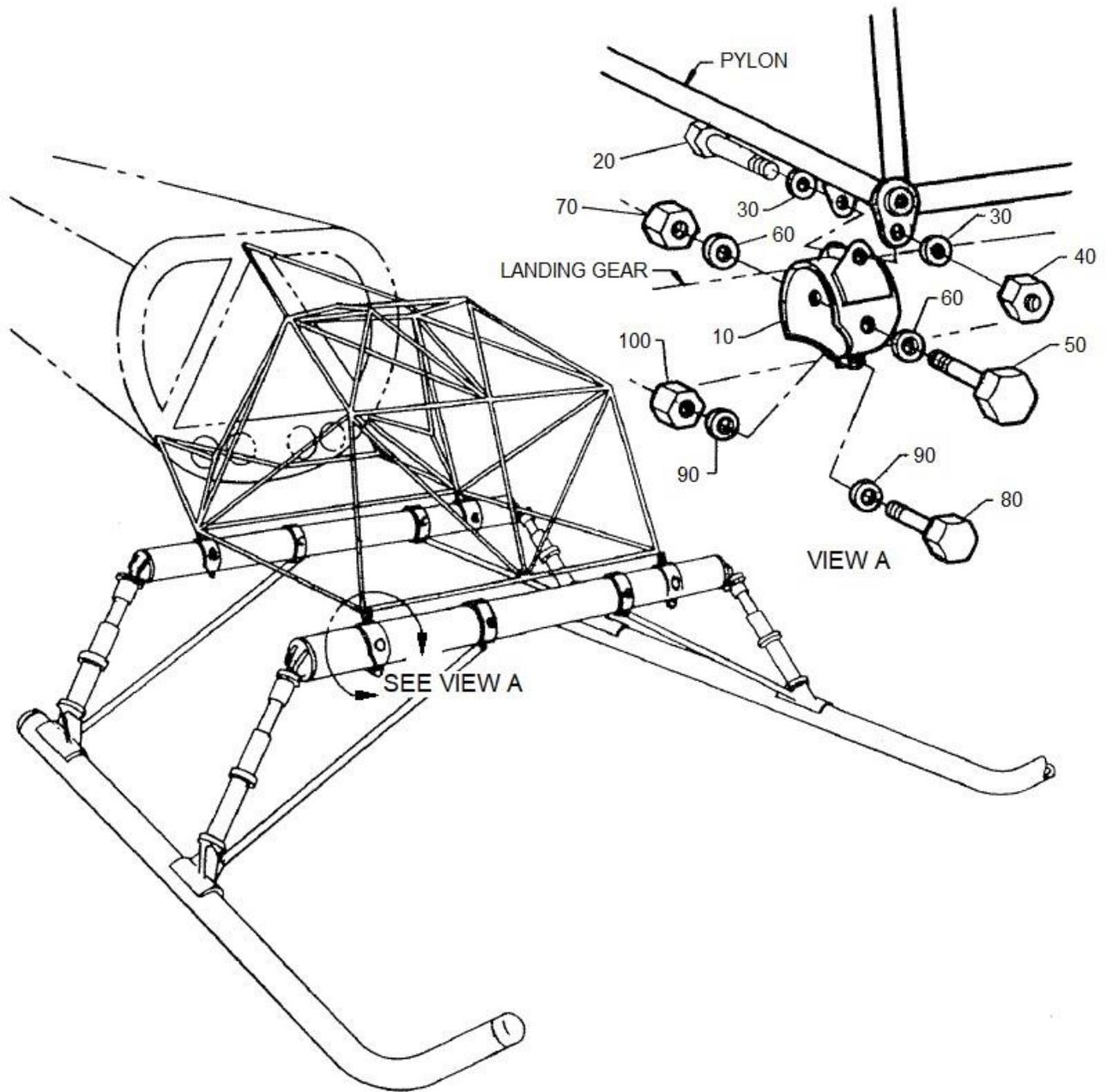

FIGURE 7-19. PYLON ASSEMBLY TO LANDING GEAR

ENSTROM F-28/280 SERIES ILLUSTRATED PARTS CATALOG

FIGURE 7-19. PYLON ASSEMBLY TO LANDING GEAR

ITEM NUMBER	PART NUMBER	DESCRIPTION	QTY PER ASSY	MODELS AFFECTED						
				F-28A	280	F-28C	280C	F-28F	280F	280FX
-	28-17100-903	Skid Gear Assembly	REF	X	X	X	X	X	X	X
-	28-17100-907	Skid Gear Assembly (Floats)	REF	X		X		X		
-	28-17100-923	Skid Gear Assembly (Heavy Duty)	REF	X	X	X	X	X	X	X
-	28-17100-927	Skid Gear Assembly (Heavy Duty/Floats)	REF	X		X		X		X
10	28-17132-1	. Landing Gear Leg Assembly, Left Fwd	1	X	X	X	X	X	X	X
20	28-17150-1	. Bolt	4	X	X	X	X	X	X	X
30	NAS1149F0663P	. Washer	8	X	X	X	X	X	X	X
30	AN960-616	. Washer (Alternate)	8	X	X	X	X	X	X	X
40	MS21083N6	. Nut	4	X	X	X	X	X	X	X
40	AN364-624A	. Nut (Superseded by MS21083N6)	4	X	X	X	X	X	X	X
-	28-17122-1	Cross Beam Assembly – Landing Gear	REF	X	X	X	X	X	X	X
50	28-17150-13	. Bolt	4	X	X	X	X	X	X	X
50	AN5-35A	. Bolt (Replaced by 28-17150-13)	4	X	X	X	X	X	X	X
60	NAS1149F0563P	. Washer	8	X	X	X	X	X	X	X
60	AN960-516	. Washer (Alternate)	8	X	X	X	X	X	X	X
70	MS21044N5	. Nut	4	X	X	X	X	X	X	X
70	AN365-524A	. Nut (Superseded by MS21044N5)	4	X	X	X	X	X	X	X
80	NAS6604-17	. Bolt	4	X	X	X	X	X	X	X
80	AN4-14A	. Bolt (Superseded by NAS6604-17)	4	X	X	X	X	X	X	X
90	NAS1149F0432P	. Washer	8	X	X	X	X	X	X	X
90	AN960-416L	. Washer (Alternate)	8	X	X	X	X	X	X	X
100	MS21044N4	. Nut	4	X	X	X	X	X	X	X
100	AN365-428A	. Nut (Superseded by MS21044N4)	4	X	X	X	X	X	X	X

ENSTROM F-28/280 SERIES ILLUSTRATED PARTS CATALOG

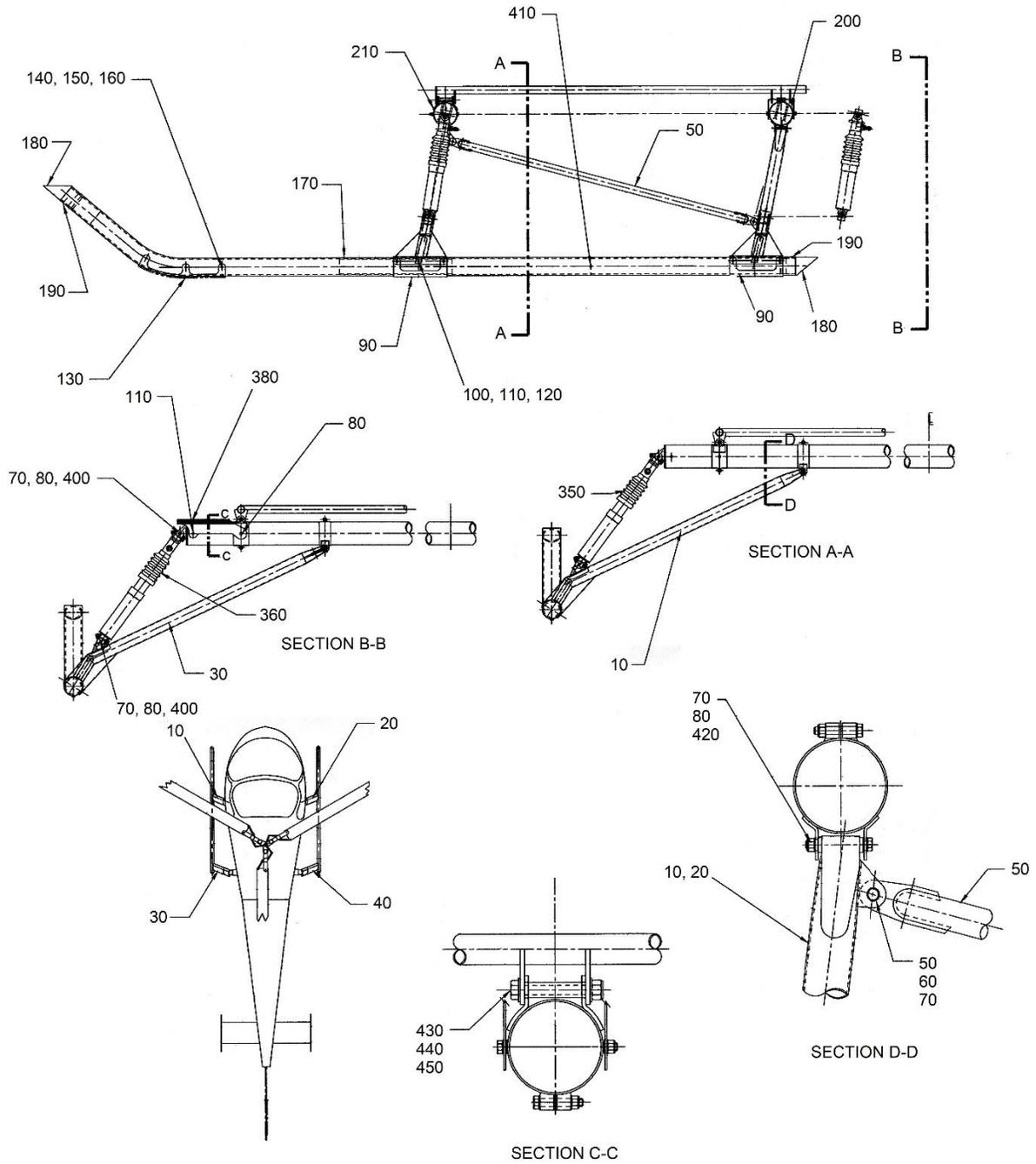
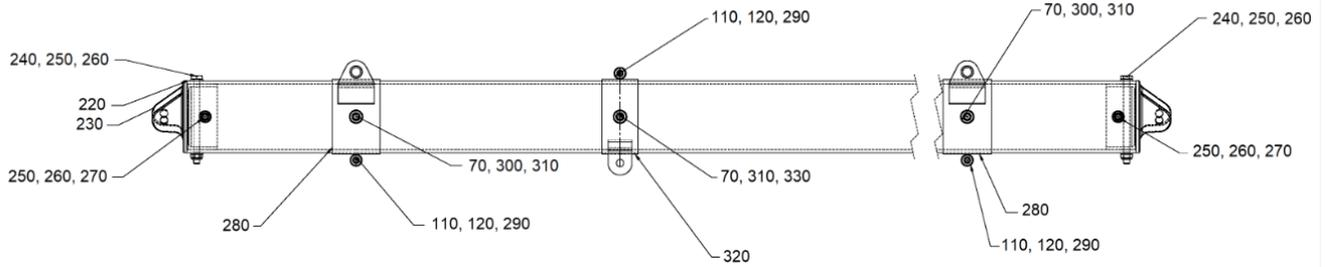
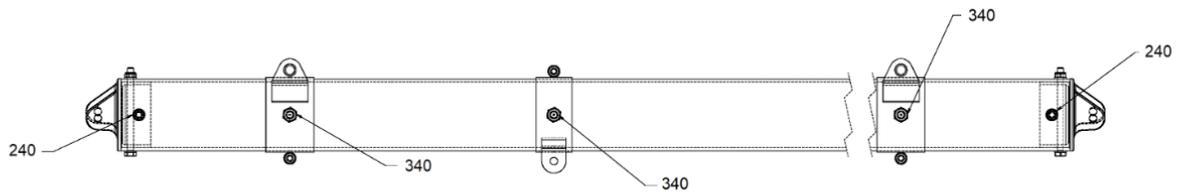

FIGURE 7-20. LANDING GEAR ASSEMBLY

ENSTROM F-28/280 SERIES ILLUSTRATED PARTS CATALOG



CROSS BEAM ASSEMBLY AFT



CROSS BEAM ASSEMBLY FWD

FIGURE 7-20. LANDING GEAR ASSEMBLY

ENSTROM F-28/280 SERIES ILLUSTRATED PARTS CATALOG

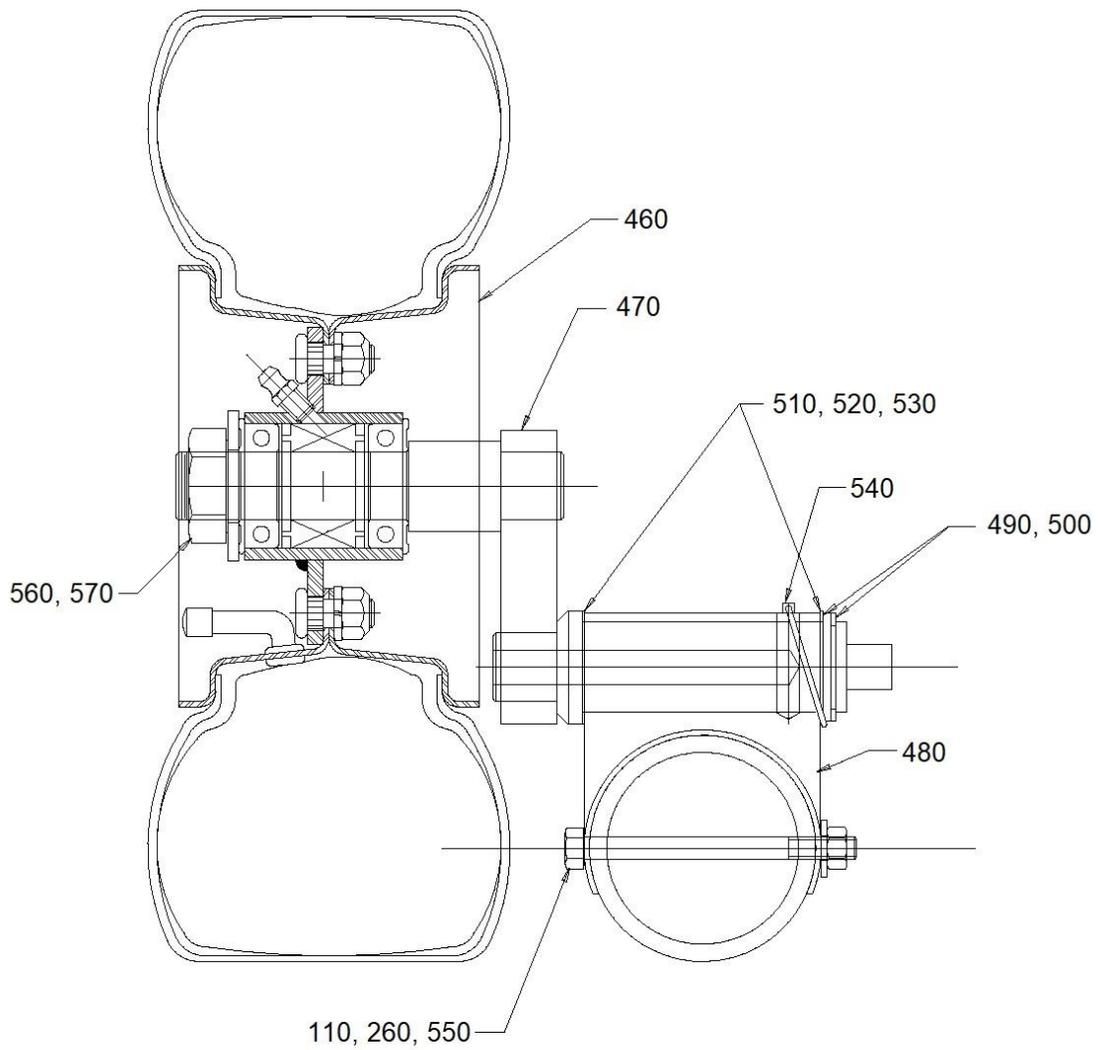

Sheet 3 of 3

FIGURE 7-20. LANDING GEAR ASSEMBLY

ENSTROM F-28/280 SERIES ILLUSTRATED PARTS CATALOG

FIGURE 7-20. LANDING GEAR ASSEMBLY

ITEM NUMBER	PART NUMBER	DESCRIPTION	QTY PER ASSY	MODELS AFFECTED						
				F-28A	280	F-28C	280C	F-28F	280F	280FX
-	28-17100-903	Skid Gear Assembly	REF	X	X	X	X	X	X	X
-	28-17100-907	Skid Gear Assembly (Floats)	REF	X		X		X		
-	28-17100-923	Skid Gear Assembly (Heavy Duty)	REF	X	X	X	X	X	X	X
-	28-17100-927	Skid Gear Assembly (Heavy Duty/Floats)	REF	X		X		X		X
10	28-17132-1	. Landing Gear Leg Assembly, Left Fwd	1	X	X	X	X	X	X	X
20	28-17132-2	. Landing Gear Leg Assembly, Right Fwd	1	X	X	X	X	X	X	X
30	28-17132-3	. Landing Gear Leg Assembly, Left Aft	1	X	X	X	X	X	X	X
40	28-17132-4	. Landing Gear Leg Assembly, Right Aft	1	X	X	X	X	X	X	X
50	28-17124-1	. Drag Strut	2	X	X	X	X	X	X	X
60	NAS6605-5	. Bolt	4	X	X	X	X	X	X	X
60	AN5-6A	. Bolt (Superseded by NAS6605-5)	4	X	X	X	X	X	X	X
70▲	MS21044N5	. Nut	A/R	X	X	X	X	X	X	X
70▲	AN365-524A	. Nut (Superseded by MS21044N5)	A/R	X	X	X	X	X	X	X
80	NAS1149F0532P	. Washer	4	X	X	X	X	X	X	X
80	AN960-516L	. Washer (Alternate)	4	X	X	X	X	X	X	X
90	28-22421-1	. Weldment	4	X	X	X	X	X	X	X
90	28-17111-1	. Wear Plate (Replaced by 28-22421-1)	4	X	X	X	X	X	X	X
-*	X-1567	. Wing Walk	A/R	X	X	X	X	X	X	
100	NAS6604-42	. Bolt	12	X	X	X	X	X	X	X
100	AN4-30A	. Bolt (Superseded by NAS6604-42)	12	X	X	X	X	X	X	X
110▲	NAS1149F0432P	. Washer	32	X	X	X	X	X	X	X
110▲	AN960-416L	. Washer (Alternate)	32	X	X	X	X	X	X	X
120▲	MS21044N4	. Nut	20	X	X	X	X	X	X	X
120▲	AN365-428A	. Nut (Superseded by MS21044N4)	20	X	X	X	X	X	X	X
130	28-17104-1	. Wear Plate Weldment	2	X	X	X	X	X	X	X
140	NAS6603-40	. Bolt	12	X	X	X	X	X	X	X

ENSTROM F-28/280 SERIES ILLUSTRATED PARTS CATALOG

FIGURE 7-20. LANDING GEAR ASSEMBLY

ITEM NUMBER	PART NUMBER	DESCRIPTION	QTY PER ASSY	MODELS AFFECTED						
				F-28A	280	F-28C	280C	F-28F	280F	280FX
140	AN3-27A	. Bolt (Superseded by NAS6603-40)	12	X	X	X	X	X	X	X
150	NAS1149F0363P	. Washer	24	X	X	X	X	X	X	X
150	AN960-10	. Washer (Alternate)	24	X	X	X	X	X	X	X
160	MS21044N3	. Nut	12	X	X	X	X	X	X	X
160	AN365-1032A	. Nut (Superseded by MS21044N3)	12	X	X	X	X	X	X	X
170	28-17102-3	. Skid Member Assembly	2	X	X	X	X	X	X	X
180*	ECD085-3	. End Cap Assembly (Option)	2	X	X	X	X	X	X	X
—*	ECD085-1	. . End Cap Assembly	2	X	X	X	X	X	X	X
—*	ECD085-13	. . . Cap	2	X	X	X	X	X	X	X
—*	732RTV	. Silicone Sealant (Used with ECD085 only)	A/R	X	X	X	X	X	X	X
—**	28-17159-11	. End Cap	4	X	X	X	X	X	X	
—	28-17106-1	. Skid Plug, Fwd (Replaced by 28-17159-11)	2	X	X	X	X	X	X	
—	28-17106-2	. Skid Plug, Aft (Replaced by 28-17159-11)	2	X	X	X	X	X	X	
190	6 X 3/8	. PK Screw	4	X	X	X	X	X	X	X
200	28-17122-1	. Cross Beam Assembly, Aft	1	X	X	X	X	X	X	X
210	28-17122-5	. Cross Beam Assembly, Fwd	1	X	X	X	X	X	X	X
220▲	28-17122-3	. . Cross Tube	2	X	X	X	X	X	X	X
230▲	28-17129-1	. . End Fitting	4	X	X	X	X	X	X	X
240▲	NAS6604-50	. . Bolt	6	X	X	X	X	X	X	X
240▲	AN4-34A	. . Bolt (Superseded by NAS6603-50)	6	X	X	X	X	X	X	X
250▲	NAS1149F0463P	. . Washer	16	X	X	X	X	X	X	X
260▲	MS21083N4	. . Nut	8	X	X	X	X	X	X	X
270●	NAS6604-56	. . Bolt	2	X	X	X	X	X	X	X
270●	AN4-37A	. . Bolt (Superseded by NAS6604-56)	2	X	X	X	X	X	X	X
280▲	28-17101-7	. . Clamp Weldment - Skid Gear	4	X	X	X	X	X	X	X
280▲	28-17101-1	. . Clamp Weldment – Skid Gear (Replaced by 28-17101-7)	4	X	X	X	X	X	X	X

ENSTROM F-28/280 SERIES ILLUSTRATED PARTS CATALOG

FIGURE 7-20. LANDING GEAR ASSEMBLY

ITEM NUMBER	PART NUMBER	DESCRIPTION	QTY PER ASSY	MODELS AFFECTED						
				F-28A	280	F-28C	280C	F-28F	280F	280FX
290▲	NAS6604-17	. . Bolt	8	X	X	X	X	X	X	X
290▲	AN4-14A	. . Bolt (Superseded by NAS6604-17)	8	X	X	X	X	X	X	X
300●	NAS6605-56	. . Bolt	2	X	X	X	X	X	X	X
300●	AN5-37A	. . Bolt (Superseded by NAS6605-56)	2	X	X	X	X	X	X	X
310▲	NAS1149F0563P	. . Washer	16	X	X	X	X	X	X	X
320▲	28-17121-1	. . Pivot Clamp Weldment	4	X	X	X	X	X	X	X
330●	NAS6605-52	. . Bolt	2	X	X	X	X	X	X	X
330●	AN5-35A	. . Bolt (Superseded by NAS6605-52)	2	X	X	X	X	X	X	X
340◆	28-17150-13	. . Bolt	4	X	X	X	X	X	X	X
350	28-17148-3	. Landing Gear Oleo	4		X		X		X	X
360	28-17148-5	. Landing Gear Oleo	4	X		X		X		
-	28-17123-1	. . Link	2	X	X	X	X	X	X	X
-370**	28-17148-7	. Landing Gear Oleo	4					X		
-**	28-17306-1	. . Link	2					X		
-	28-17135-11	. . Bolt	2	X	X	X	X	X	X	X
-	NAS1149F0532P	. . Washer	8	X	X	X	X	X	X	X
-	AN960-516L	. . Washer (Alternate)	8	X	X	X	X	X	X	X
-	MS21083N5	. . Nut	2	X	X	X	X	X	X	X
-	AN364-524A	. . Nut (Superseded by MS21083N5)	2	X	X	X	X	X	X	X
380	28-17166-1	. Cover - Aft Crosstube, L/H	1	X	X	X	X	X	X	X
-390	28-17166-2	. Cover - Aft Crosstube. R/H	1	X	X	X	X	X	X	X
400	NAS6605-23	. Bolt	8	X	X	X	X	X	X	X
400	AN5-17A	. Bolt (Superseded by NAS6605-23)	8	X	X	X	X	X	X	X
410	CCR274SS-3-04	. Rivet	2	X	X	X	X	X	X	X
420	NAS6605-29	. Bolt	4	X	X	X	X	X	X	X
420	AN5-22A	. Bolt (Superseded by NAS6605-29)	4	X	X	X	X	X	X	X

ENSTROM F-28/280 SERIES ILLUSTRATED PARTS CATALOG

FIGURE 7-20. LANDING GEAR ASSEMBLY

ITEM NUMBER	PART NUMBER	DESCRIPTION	QTY PER ASSY	MODELS AFFECTED						
				F-28A	280	F-28C	280C	F-28F	280F	280FX
430	28-17150-1	. Frame Attaching Bolt	4	X	X	X	X	X	X	X
440	MS21044N6	. Nut	4	X	X	X	X	X	X	X
450	NAS1149F0632P	. Washer	8	X	X	X	X	X	X	X
-	28-17000-1	Ground Handling Wheel/Axle Installation	REF	X	X	X	X	X	X	X
460	ECD083-1	. Wheel Assembly	2	X	X	X	X	X	X	X
470	28-17002-11	. Axle Assembly	2	X	X	X	X	X	X	X
480	28-17001-101	. Bracket Assembly (Weldment)	2	X	X	X	X	X	X	X
490	28-17004-1	. Washer	2	X	X	X	X	X	X	X
500	5108-100	. Retaining Ring	2	X	X	X	X	X	X	X
510	28-17000-11	. Shim .020"	A/R	X	X	X	X	X	X	X
520	28-17000-13	. Shim .025"	A/R	X	X	X	X	X	X	X
530	28-17000-15	. Shim .035"	A/R	X	X	X	X	X	X	X
540	KLIK-1185	. Detent Pin	2	X	X	X	X	X	X	X
540	BLDS4-13W/LT	. Detent Pin (Replaced by KLIK-1185)	2	X	X	X	X	X	X	X
550	NAS6604-40	. Bolt	6	X	X	X	X	X	X	X
550	AN4-27A	. Bolt (Superseded by NAS6604-40)	6	X	X	X	X	X	X	X
560	MS21083N12	. Nut	2	X	X	X	X	X	X	X
560	AN364-1216A	. Nut (Superseded by MS21083N12)	2	X	X	X	X	X	X	X
570	NAS1149C1290R	. Washer	2	X	X	X	X	X	X	X
570	AN960-C1216	. Washer (Alternate)	2	X	X	X	X	X	X	X

- * Used on aircraft equipped without floats.
- ** F-28F float installation only.
- ▲ Parts used in 28-17122-1 and 28-17122-5 assemblies.
- Part used in 28-17122-1 assembly.
- ◆ Part used in 28-17122-5 assembly.

ENSTROM F-28/280 SERIES ILLUSTRATED PARTS CATALOG

|

INTENTIONALLY LEFT BLANK

ENSTROM F-28/280 SERIES ILLUSTRATED PARTS CATALOG

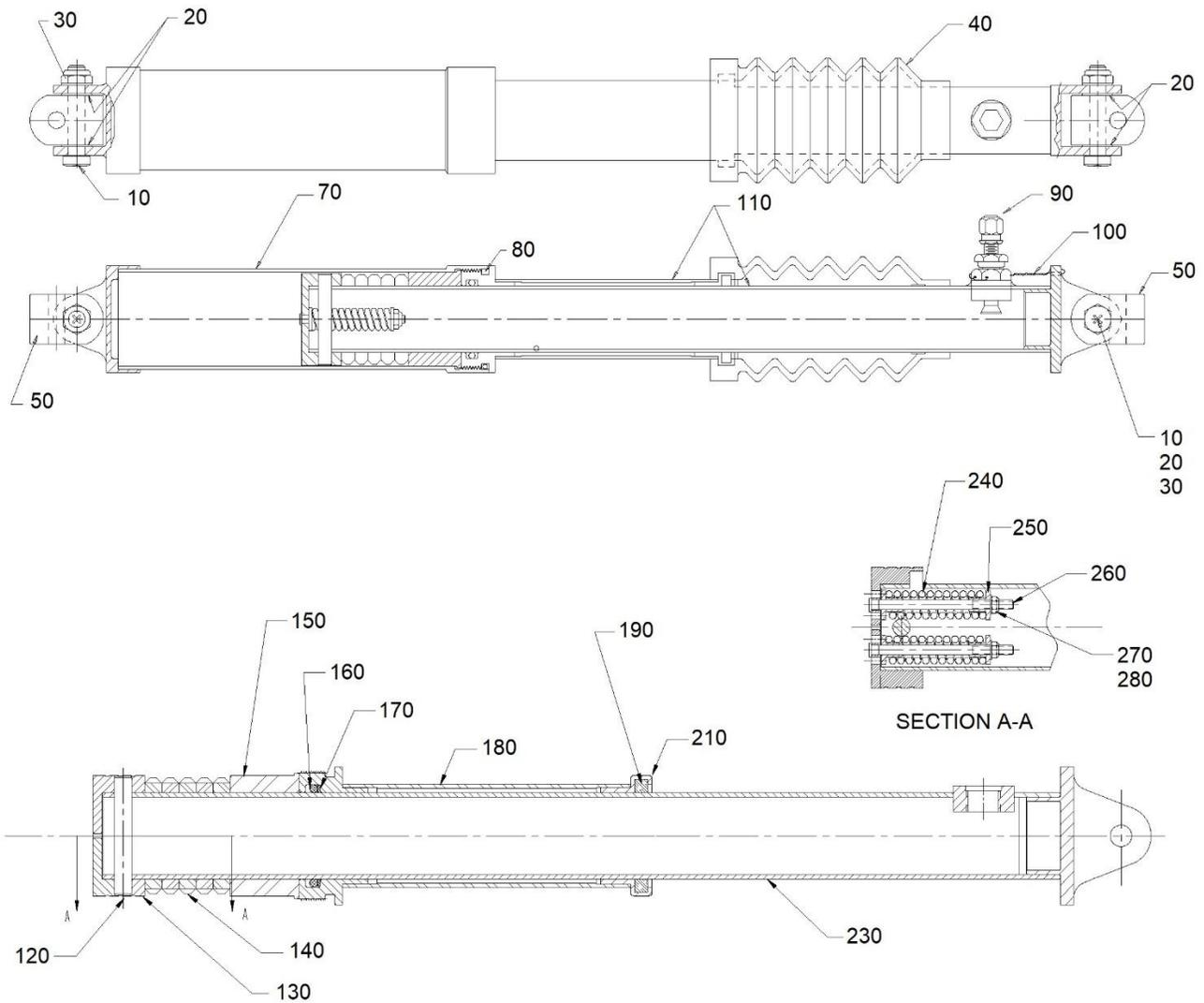

FIGURE 7-21. OLEO STRUT ASSEMBLY

ENSTROM F-28/280 SERIES ILLUSTRATED PARTS CATALOG

FIGURE 7-21. OLEO STRUT ASSEMBLY

ITEM NUMBER	PART NUMBER	DESCRIPTION	QTY PER ASSY	MODELS AFFECTED						
				F-28A	280	F-28C	280C	F-28F	280F	280FX
-	28-17148-1	Landing Gear Oleo Assembly (Obsolete)	REF	X	X	X	X	X	X	X
-	28-17148-2	Landing Gear Oleo Assembly (Float Installation) (Obsolete)	REF	X	X	X	X	X	X	
-	28-17148-3	Landing Gear Oleo Assembly	REF							X
-	28-17148-5	Landing Gear Oleo Assembly	REF	X	X	X	X	X	X	
-	28-17148-7	Landing Gear Oleo Assembly (Float Installation)	REF	X	X	X	X	X	X	X
10	28-17135-11	. Bolt	2	X	X	X	X	X	X	X
20	NAS1149F0532P	. Washer	8	X	X	X	X	X	X	X
20	AN960-516L	. Washer (Alternate)	8	X	X	X	X	X	X	X
30	MS21083N4	. Nut	2	X	X	X	X	X	X	X
30	AN364-524A	. Nut (Superseded by MS21083N4)	2	X	X	X	X	X	X	X
40	28-17158-1	. Strut Cover	1	X	X	X	X	X	X	
50	28-17123-1	. Link (Used with 28-17148-3 & 28-17148-5)	2	X	X	X	X	X	X	X
-60	28-17306-1	. Link (Used with 28-17148-7)	2	X	X	X	X	X	X	X
70	28-17140-1	. Cylinder Assembly	1	X	X	X	X	X	X	X
80*	2-131 N304-75	. O-Ring	1	X	X	X	X	X	X	X
-	471-RED	. Red Vinyl Tape	A/R	X	X	X	X	X	X	X
90	MS28889-2	. Strut Valve	1	X	X	X	X	X	X	X
100	MS20995C32	. Safety Wire	A/R	X	X	X	X	X	X	X
110	28-17147-7	. Piston Shaft Assembly	1	X	X	X	X	X	X	X
120	28-17147-3	. . Pin	1	X	X	X	X	X	X	X
130	28-17145-1	. . Piston	1	X	X	X	X	X	X	X
140	28-17151-1	. . Rebound Ring	5	X	X	X	X	X	X	X
150	28-17149-1	. . Spacer	1	X	X	X	X	X	X	X
160◇	MS28775-218	. . O-Ring	1	X	X	X	X	X	X	X
170	8-218-N300-9	. . Back-Up Ring	1	X	X	X	X	X	X	X
180	28-17144-5	. . Seal Housing Assembly	1	X	X	X	X	X	X	X
180	28-17144-1	. . Seal Housing Assembly (Replaced by 28-17144-5)	1	X	X	X	X	X	X	X

ENSTROM F-28/280 SERIES ILLUSTRATED PARTS CATALOG

FIGURE 7-21. OLEO STRUT ASSEMBLY

ITEM NUMBER	PART NUMBER	DESCRIPTION	QTY PER ASSY	MODELS AFFECTED						
				F-28A	280	F-28C	280C	F-28F	280F	280FX
190●	D1250	. . Wiper Seal	1	X	X	X	X	X	X	X
-200▲	28-17154-1	. . Wiper	1	X	X	X	X	X	X	X
210●	28-17153-13	. . Guide	1	X	X	X	X	X	X	X
-220▲	28-17153-1	. . Guide	1	X	X	X	X	X	X	X
230	28-17146-7	. . Piston Tube Assembly	1	X	X	X	X	X	X	X
230	28-17146-1	. . Piston Tube Assembly (Superseded by 28-17146-7)	1	X	X	X	X	X	X	X
240	28-17155-1	. . Valve Spring	2	X	X	X	X	X	X	X
250	28-17156-3	. . Valve Piston	4	X	X	X	X	X	X	X
250	28-17156-1	. . Valve Piston (Superseded by 28-17156-3)	4	X	X	X	X	X	X	X
260	28-17157-1	. . Shaft	2	X	X	X	X	X	X	X
270	NAS1149FN632P	. . Washer	2	X	X	X	X	X	X	X
270	AN960-6	. . Washer (Alternate)	2	X	X	X	X	X	X	X
280	MS21044N06	. . Nut	2	X	X	X	X	X	X	X
280	AN365-632A	. . Nut (Superseded by MS21044N06)	2	X	X	X	X	X	X	X

* MS28775-131 is an acceptable alternate.

◇ 2-218 is an acceptable alternate.

● For aircraft produced after 5/20/85 through 5/12/03, use D1250 wiper with 28-17153-13 guide.

▲ For aircraft produced prior to 5/20/85, use 28-17154-1 wiper with 28-17153-1 guide.

ENSTROM F-28/280 SERIES ILLUSTRATED PARTS CATALOG

|

INTENTIONALLY LEFT BLANK

ENSTROM F-28/280 SERIES ILLUSTRATED PARTS CATALOG

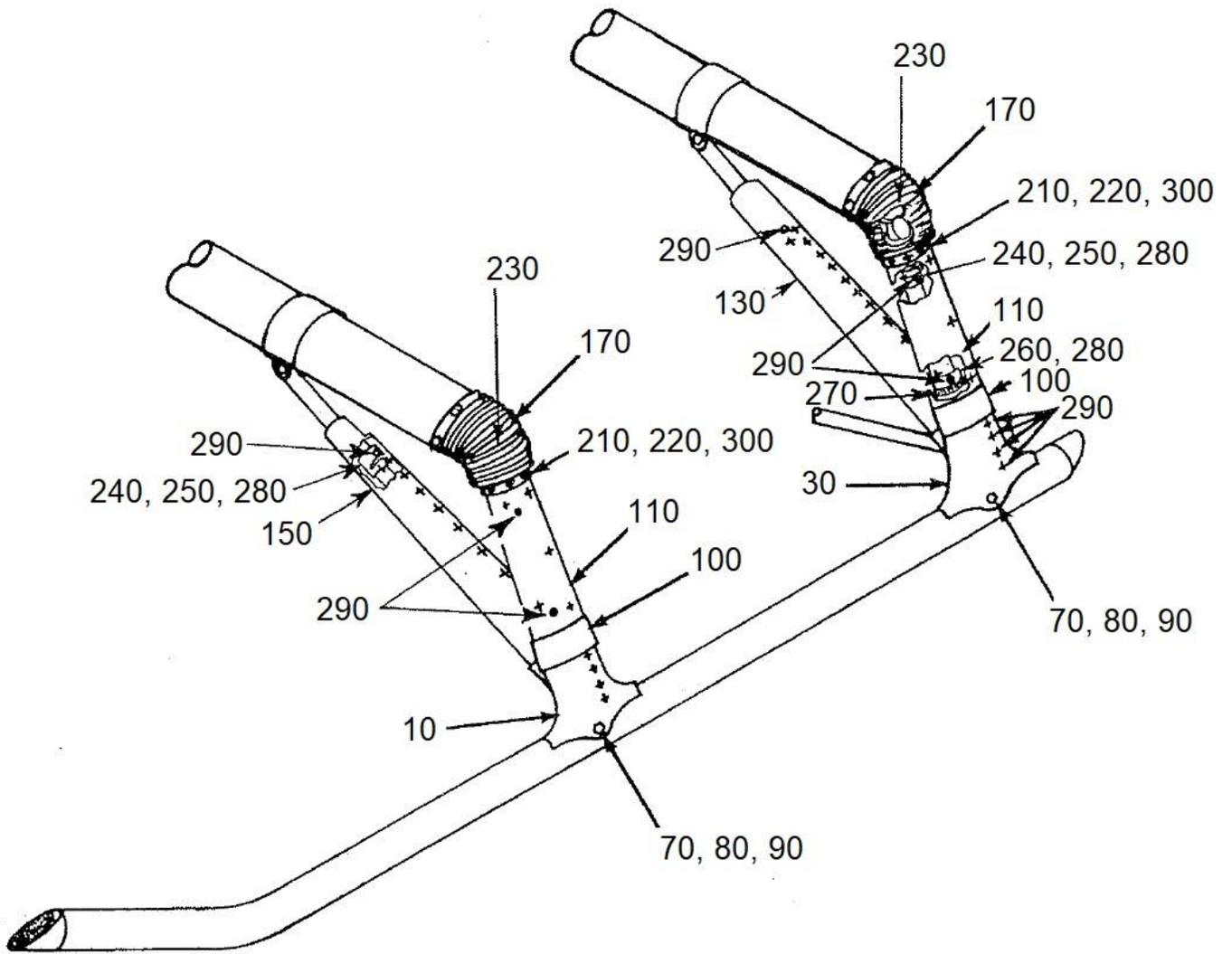

FIGURE 7-22. LANDING GEAR FAIRINGS

ENSTROM F-28/280 SERIES ILLUSTRATED PARTS CATALOG

FIGURE 7-22. LANDING GEAR FAIRINGS

ITEM NUMBER	PART NUMBER	DESCRIPTION	QTY PER ASSY	MODELS AFFECTED						
				F-28A	280	F-28C	280C	F-28F	280F	280FX
-	28-17142-1	Fairings Assembly (No Step)	REF							X
-	28-17142-3	Fairings Assembly (No Step & Oleo Extenders)	REF							X
-	28-17142-5	Fairings Assembly (Step)	REF							X
-	28-17142-7	Fairings Assembly (Step & Oleo Extenders)	REF							X
10*	28-17141-1	. Fairing, L/H	1							X
-20*	28-17141-2	. Fairing, R/H	1							X
30	28-17141-3	. Fairing, L/H	1							X
-40	28-17141-4	. Fairing, R/H	1							X
-50●	28-17141-5	. Fairing, L/H	1							X
-60●	28-17141-6	. Fairing, R/H	1							X
70	NAS6604-44	. Bolt	4							X
70	AN4-31A	. Bolt (Superseded by NAS6604-44)	4							X
80	NAS1149F0432P	. Washer	8							X
80	AN960-416L	. Washer (Alternate)	8							X
90	MS20365-425	. Nut	4							X
90	AN365-425	. Nut (Alternate)	4							X
100	28-17120-11	. Sleeve	4							X
110	28-17108-1	. Fairing, L/H	2							X
-120	28-17108-2	. Fairing, R/H	2							X
130	28-17139-1	. Fairing, Aft, L/H	1							X
-140	28-17139-2	. Fairing, Aft, R/H	1							X
150	28-17139-3	. Fairing, Fwd, L/H	1							X
-160	28-17139-4	. Fairing, Fwd, R/H	1							X
170	28-17119-15	. Boot	4							X
170	28-17119-11	. Boot, L/H (Replaced by 28-17119-15)	2							X
-180	28-17119-12	. Boot, R/H (Replaced by 28-17119-15)	2							X

ENSTROM F-28/280 SERIES ILLUSTRATED PARTS CATALOG

FIGURE 7-22. LANDING GEAR FAIRINGS

ITEM NUMBER	PART NUMBER	DESCRIPTION	QTY PER ASSY	MODELS AFFECTED						
				F-28A	280	F-28C	280C	F-28F	280F	280FX
-190	28-17119-13	. Boot, L/H (Replaced by 28-17119-15)	2							X
-200	28-17119-14	. Boot, R/H (Replaced by 28-17119-15)	2							X
210	28-17161-11	. Strap	4							X
220	28-17162-11	. Washer	4							X
230	28-17138-1	. Support	4							X
240	28-17113-13	. Clamp	8							X
250	20020S	. Clamp	8							X
260	28-17143-11	. Clamp	4							X
270	20024S	. Clamp	4							X
280	A01789-8Z1D	. Tinnerman Nut	A/R							X
280	A1787-8Z-1	. Tinnerman Nut (Superseded by A01789-8Z1D)	A/R							X
290	8 X 1/2	. Screw	A/R							X
300	8 X 3/8	. Screw	2							X

* Used in 28-17142-1 and 28-17142-3.

• Used in 28-17142-5 and 28-17142-7.

ENSTROM F-28/280 SERIES ILLUSTRATED PARTS CATALOG

|

INTENTIONALLY LEFT BLANK

ENSTROM F-28/280 SERIES ILLUSTRATED PARTS CATALOG

SECTION 12

TAIL ROTOR SYSTEM

TABLE OF CONTENTS

	Cover Page	12-1
	Table of Contents	12-1
12-1	Tail Rotor Transmission Assembly	12-3
12-2	Flex Coupling Installation	12-7
12-3	Tail Rotor Hanger Bearing Installation	12-11
12-4	Rotor Tachometer Assembly	12-13
12-5	Tail Rotor Blade Control Installation	12-17
12-6	Tail Rotor Pitch Link Assembly	12-29
12-7	Tail Rotor Mechanical Controls (Right Hand Gearbox)	12-33
12-8	Tail Rotor Mechanical Controls (Left Hand Gearbox)	12-37
12-9	28-15018-3 Tail Rotor Assembly	12-41
12-10	28-150000-7, -10 Tail Rotor Assembly	12-45
12-11	28-150050-2 Tail Rotor Assembly	12-49
12-12	28-150073-1, -5 Tail Rotor Assembly	12-53
12-13	28-150079-1, -5 Tail Rotor Assembly	12-57

ENSTROM F-28/280 SERIES ILLUSTRATED PARTS CATALOG

I

INTENTIONALLY LEFT BLANK

ENSTROM F-28/280 SERIES ILLUSTRATED PARTS CATALOG

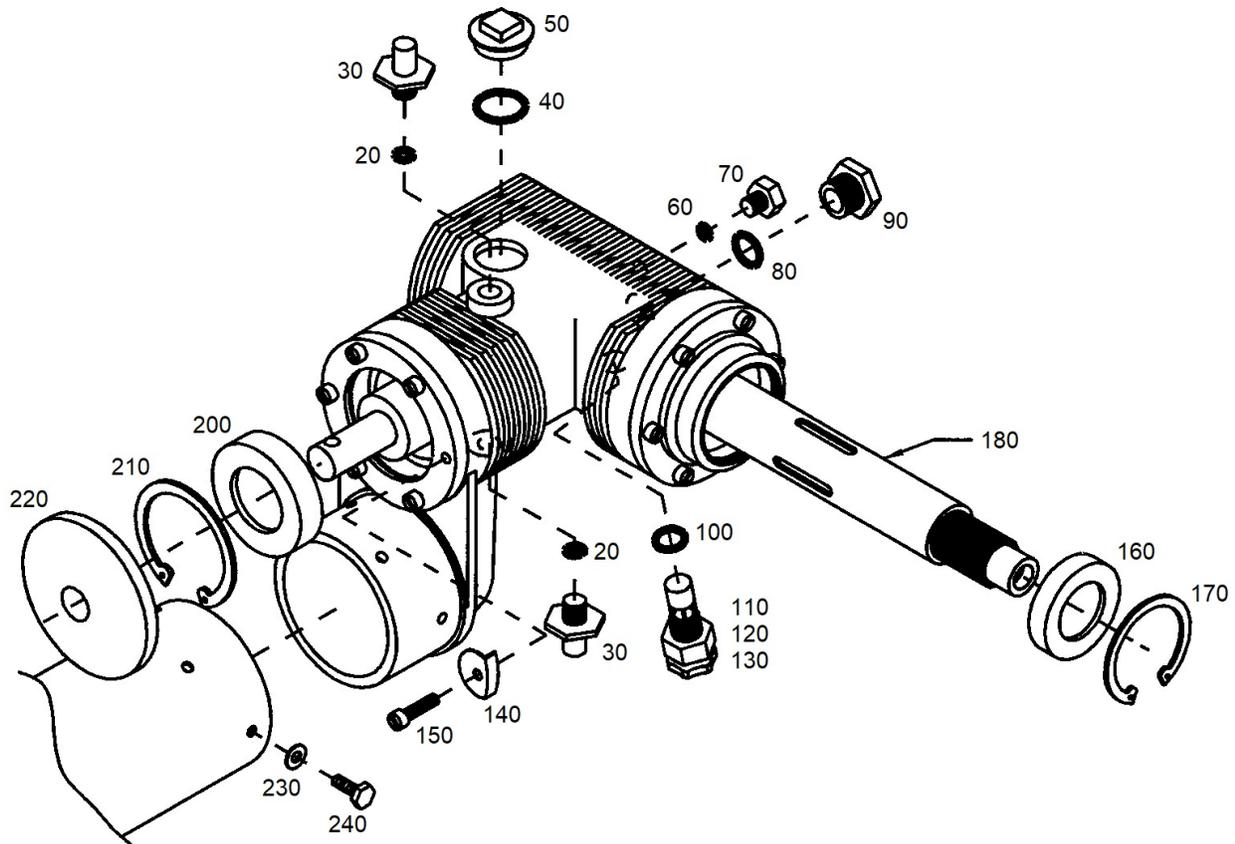

FIGURE 12-1. TAIL ROTOR TRANSMISSION ASSEMBLY

ENSTROM F-28/280 SERIES ILLUSTRATED PARTS CATALOG

FIGURE 12-1. TAIL ROTOR TRANSMISSION ASSEMBLY

ITEM NUMBER	PART NUMBER	DESCRIPTION	QTY PER ASSY	MODELS AFFECTED						
				F-28A	280	F-28C	280C	F-28F	280F	280FX
-10	28-13525-5	. Tail Rotor Transmission Assembly	1	X	X	X	X	X	X	
10A*	28-13525-7	. Tail Rotor Transmission Assembly	1					X		X
20	MS28778-3	.. O-Ring	2	X	X	X	X	X	X	X
30	28-135003-11	.. Bolt	2	X	X	X	X	X	X	X
30	28-135003-1	.. Bolt (Superseded by 28-135003-11)	2	X	X	X	X	X	X	X
40	MS28775-018	.. O-Ring	1	X	X	X	X	X	X	X
50	28-13515-3	.. Plug	1	X	X	X	X	X	X	X
60	MS28778-2	.. O-Ring	1	X	X	X	X	X	X	X
70	AN814-2DL	.. Plug	1	X	X	X	X	X	X	X
80	MS28775-113	.. O-Ring	1	X	X	X	X	X	X	X
90	S83BZ-2	.. Sight Plug	1	X	X	X	X	X	X	X
100	MS35769-9	.. Gasket	1	X	X	X	X	X	X	X
-110	CD7L	.. Chip Detector (Used with 28-13525-5)	1	X	X	X	X	X	X	
110A	K94RA	.. Chip Detector (Used with 28-13525-7)	1					X		X
120	M83248/1-008	.. O-Ring (Alternate)	1	X	X	X	X	X	X	X
130	21FA-540	.. Nut	1	X	X	X	X	X	X	X
140**	28-13531-11	.. Tab	2	X	X	X	X	X	X	X
150	NAS1351-3H10P	.. Screw	12	X	X	X	X	X	X	X
160	28-13532-11	.. Seal	1	X	X	X	X	X	X	X
170	N5000-175-PP	.. Retaining Ring	1	X	X	X	X	X	X	X
180	28-13511-11	.. Spacer	1	X	X	X	X	X	X	X
-190	28-13145-1	.. Placard	1	X	X	X	X	X	X	X
200‡	1539-001	. Seal	1	X	X	X	X	X	X	X
210‡	N5000-206-PP	. Retaining Ring	1	X	X	X	X	X	X	X
220‡	28-16399-13	. Slinger	1	X	X	X	X	X	X	X
230†	NAS1149F0332P	. Washer	6	X	X	X	X	X	X	X
230†	AN960-10L	. Washer (Alternate)	6	X	X	X	X	X	X	X

ENSTROM F-28/280 SERIES ILLUSTRATED PARTS CATALOG

FIGURE 12-1. TAIL ROTOR TRANSMISSION ASSEMBLY

ITEM NUMBER	PART NUMBER	DESCRIPTION	QTY PER ASSY	MODELS AFFECTED						
				F-28A	280	F-28C	280C	F-28F	280F	280FX
240†	NAS6603H1	. Bolt	6	X	X	X	X	X	X	X
240†	AN3H3A	. Bolt (Superseded by NAS6603H1)	6	X	X	X	X	X	X	X
-250†	MS20995C32	. Safety Wire	A/R	X	X	X	X	X	X	X

- * Available as a remanufactured part (-R).
- ** Omitted if retaining ring is present (Item 210).
- ‡ Part called out in P/N 28-13504-3 assembly.
- † Part called out in P/N 28-16398 installation.

ENSTROM F-28/280 SERIES ILLUSTRATED PARTS CATALOG

I

INTENTIONALLY LEFT BLANK

ENSTROM F-28/280 SERIES ILLUSTRATED PARTS CATALOG

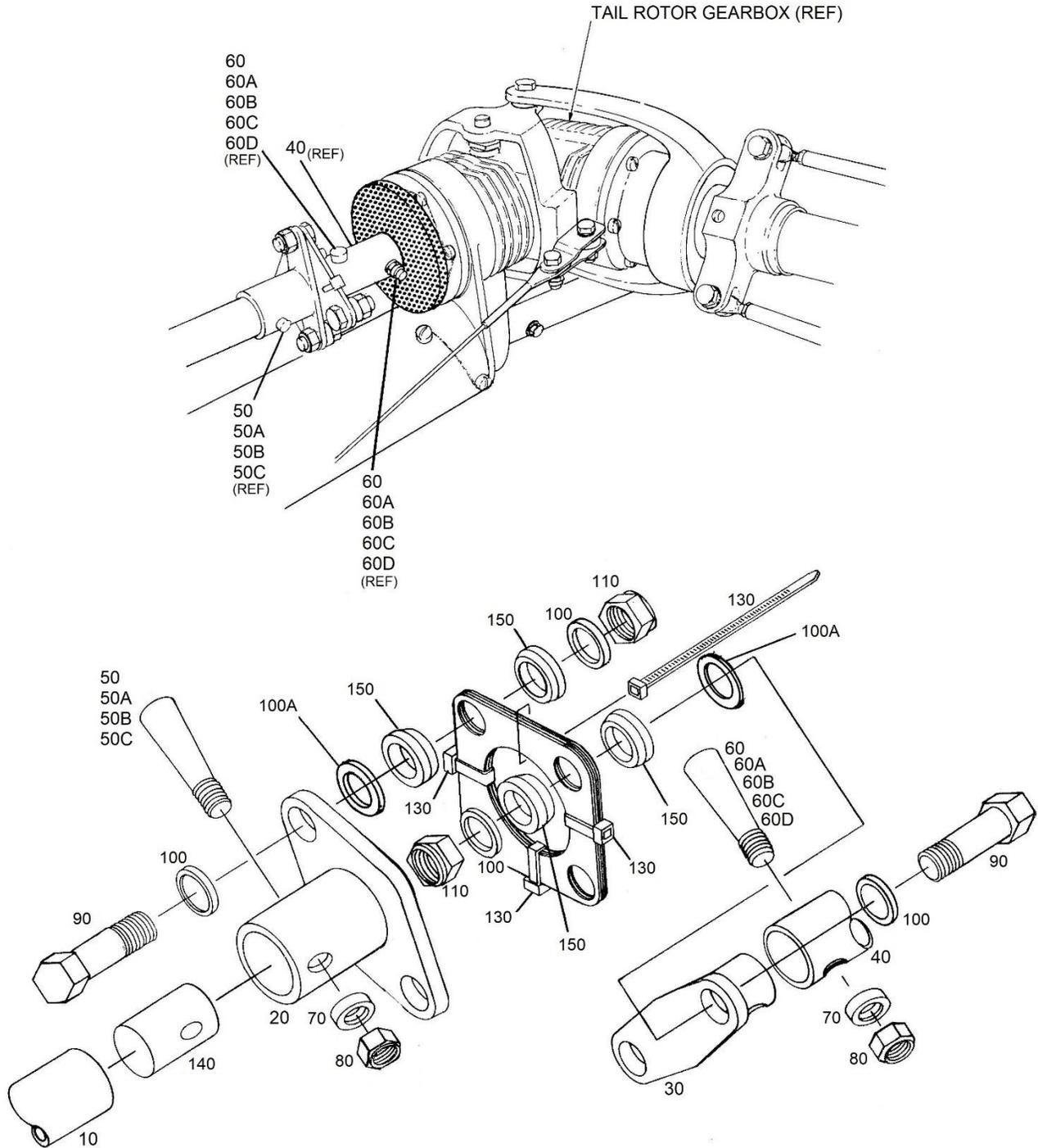

FIGURE 12-2. FLEX COUPLING INSTALLATION

ENSTROM F-28/280 SERIES ILLUSTRATED PARTS CATALOG

FIGURE 12-2. FLEX COUPLING INSTALLATION

ITEM NUMBER	PART NUMBER	DESCRIPTION	QTY PER ASSY	MODELS AFFECTED						
				F-28A	280	F-28C	280C	F-28F	280F	280FX
-5*	28-13617-903	Tail Rotor Drive Shaft Assembly	REF	X	X			X	X	X
-5A*	28-13617-905	Tail Rotor Drive Shaft Assembly	REF			X	X			
10	28-13618-1	. . Tail Rotor Drive Shaft	1	X	X	X	X	X	X	X
20**	28-13613-1	. . Coupling Hub	2	X	X	X	X	X	X	X
-20A	28-13613-901	. . Coupling Hub (Drilled)	2	X	X	X	X	X	X	X
30	28-13614-1	. Coupling Hub	1	X	X	X	X	X	X	X
-30A	28-13614-1DR	. Coupling Hub (Drilled)	1	X	X	X	X	X	X	X
40	28-13607-1	. Sleeve	1	X	X	X	X	X	X	X
50**	AN386-2-8A	. . Taper Pin (Head Dia. .296"/7.5 mm) (Grip 1.00"/25.4 mm)	2	X	X	X	X	X	X	X
50A	28-13623-11	. O/S Taper Pin (Head Dia. .305"/7.6 mm) (Grip 1.12"/28.4 mm)	A/R	X	X	X	X	X	X	X
50A	28-13600-6	. O/S Taper Pin (Superseded by 28-13623-11)	A/R	X	X	X	X	X	X	X
50B	28-13623-13	. O/S Taper Pin (Head Dia. .310"/7.8 mm) (Grip 1.12"/28.4 mm)	A/R	X	X	X	X	X	X	X
50B	28-13600-7	. O/S Taper Pin (Superseded by 28-13623-13)	A/R	X	X	X	X	X	X	X
50C	28-13623-17	. O/S Taper Pin (Head Dia. .318"/8 mm) (Grip 1.12"/28.4 mm)	A/R	X	X	X	X	X	X	X
50C	28-13600-8	. O/S Taper Pin (Superseded by 28-13623-17)	A/R	X	X	X	X	X	X	X
60	AN386-2-7A	. Taper Pin (Head Dia. .296"/7.5 mm) (Grip 1.00"/25.4 mm)	1	X	X	X	X	X	X	X
60A	28-13623-25	. O/S Taper Pin (Head Dia. .302"/7.6 mm) (Grip 1.00"/25.4 mm)	A/R	X	X	X	X	X	X	X
60A	28-13600-3	. O/S Taper Pin (Superseded by 28-13623-25)	A/R	X	X	X	X	X	X	X
60B	28-13623-27	. O/S Taper Pin (Head Dia. .307"/7.7 mm) (Grip 1.00"/25.4 mm)	A/R	X	X	X	X	X	X	X
60B	28-13600-4	. O/S Taper Pin (Superseded by 28-13623-27)	A/R	X	X	X	X	X	X	X

ENSTROM F-28/280 SERIES ILLUSTRATED PARTS CATALOG

FIGURE 12-2. FLEX COUPLING INSTALLATION

ITEM NUMBER	PART NUMBER	DESCRIPTION	QTY PER ASSY	MODELS AFFECTED						
				F-28A	280	F-28C	280C	F-28F	280F	280FX
60C	28-13623-29	. O/S Taper Pin (Head Dia. .314"/7.9 mm) (Grip 1.00"/25.4 mm)	A/R	X	X	X	X	X	X	X
60C	28-13600-5	. O/S Taper Pin (Superseded by 28-13623-29)	A/R	X	X	X	X	X	X	X
60D	28-13623-31	. O/S Taper Pin (Head Dia. .316"/8 mm) (Grip 1.00"/25.4 mm)	A/R	X	X	X	X	X	X	X
70	AN975-3	. . Washer	2	X	X	X	X	X	X	X
80**	MS21044N3	. . Nut	2	X	X	X	X	X	X	X
80**	AN365-1032A	. . Nut (Alternate)	3	X	X	X	X	X	X	X
90	NAS6604D7	. Bolt	4	X	X	X	X	X	X	X
90	AN4-7A	. Bolt (Superseded by NAS6604D7)	4	X	X	X	X	X	X	X
100	AN960C416L	. Washers	8	X	X	X	X	X	X	X
100A	AN960C416L	. Washers (For Alignment of Flex Plates)	A/R	X	X	X	X	X	X	X
110	MS21044N4	. Nut	4	X	X	X	X	X	X	X
110	AN365-428A	. Nut (Superseded by MS21044N4)	4	X	X	X	X	X	X	X
120Δ	28-01041-1	. Flex Pack Kit	1	X	X	X	X	X	X	X
120	28-01041-3	. Flex Pack Assembly	1	X	X	X	X	X	X	X
120	A005-1991	. Flex Pack (Superseded by 28-01041-3)	1	X	X	X	X	X	X	X
130	SST1.5I-M	. Cable Tie	4	X	X	X	X	X	X	X
140**	28-13619-1	. . Plug	2	X	X	X	X	X	X	X
150	28-13621-13	. Washer	8	X	X	X	X	X	X	X
150	28-13621-11	. Washer (Replaced by 28-13621-13)	8	X	X	X	X	X	X	X

ENSTROM F-28/280 SERIES ILLUSTRATED PARTS CATALOG

- * Drive shaft assembly including forward and aft hub assemblies. Included parts indented where noted by double dot.
- ** Quantity as ordered under P/N 28-13617-903/-905.
(Otherwise, Items 2 and 16 are Qty 1; Item 9 is Qty 3.)
- Special use only, as determined by Customer Service.
(Dimension to transmission input shaft .40"/.38".)
- Δ Kit includes P/N 28-01041-3 (Qty 1) and P/N 28-13621-13 (Qty 8).

ENSTROM F-28/280 SERIES ILLUSTRATED PARTS CATALOG

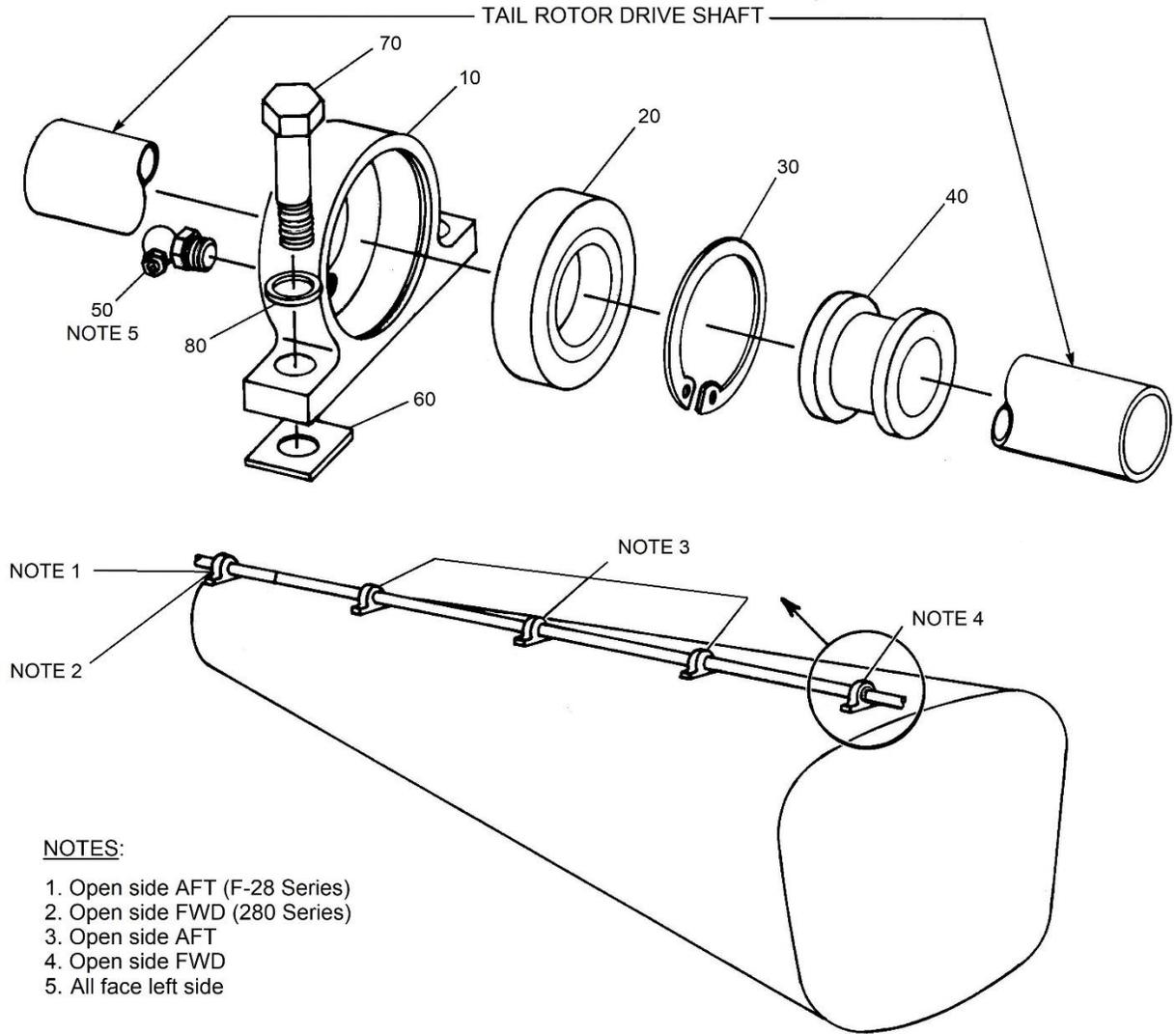

- NOTES:**
- 1. Open side AFT (F-28 Series)
 - 2. Open side FWD (280 Series)
 - 3. Open side AFT
 - 4. Open side FWD
 - 5. All face left side

FIGURE 12-3. TAIL ROTOR HANGER BEARING INSTALLATION

ENSTROM F-28/280 SERIES ILLUSTRATED PARTS CATALOG

FIGURE 12-3. TAIL ROTOR HANGER BEARING INSTALLATION

ITEM NUMBER	PART NUMBER	DESCRIPTION	QTY PER ASSY	MODELS AFFECTED						
				F-28A	280	F-28C	280C	F-28F	280F	280FX
-5	28-13617-902	. Bearing Housing Assembly	5	X	X	X	X	X	X	X
10	28-13611-1	. . Bearing Housing	1	X	X	X	X	X	X	X
20	ECD015-11	. . Bearing	1	X	X	X	X	X	X	X
30	N5000-187-ZD	. . Snap Ring	1	X	X	X	X	X	X	X
40	28-13606-1	. . Bushing	1	X	X	X	X	X	X	X
50	1637-B	. . Lube Fitting	1	X	X	X	X	X	X	X
-55*	28-11238-1	. Bracket Assembly	1							X
60	28-13605-3	. Shim .003	A/R	X	X	X	X	X	X	X
60	28-13605-4	. Shim .007	A/R	X	X	X	X	X	X	X
60	28-13605-5	. Shim .020	A/R	X	X	X	X	X	X	X
60	28-13605-6	. Shim .032	A/R	X	X	X	X	X	X	X
60	28-13605-7	. Shim .063	A/R	X	X	X	X	X	X	X
60	28-13605-8	. Shim .025	A/R	X	X	X	X	X	X	X
70	AN3-5A	. Bolt (Length AR)	8	X	X	X	X	X	X	X
70	NAS6603D4	. Bolt	2	X	X	X	X	X	X	X
70A**	AN3H5A	. Bolt (Length AR) (Superseded by NAS6603D4)	2	X	X	X	X	X	X	X
80	NAS1149C0332R	. Washer	10	X	X	X	X	X	X	X
80	AN960-C10L	. Washer (Alternate)	10	X	X	X	X	X	X	X

* Install under aft-most bearing housing on 280FX models for drive shaft cover.

** Installed at aft-most bearing housing.

ENSTROM F-28/280 SERIES ILLUSTRATED PARTS CATALOG

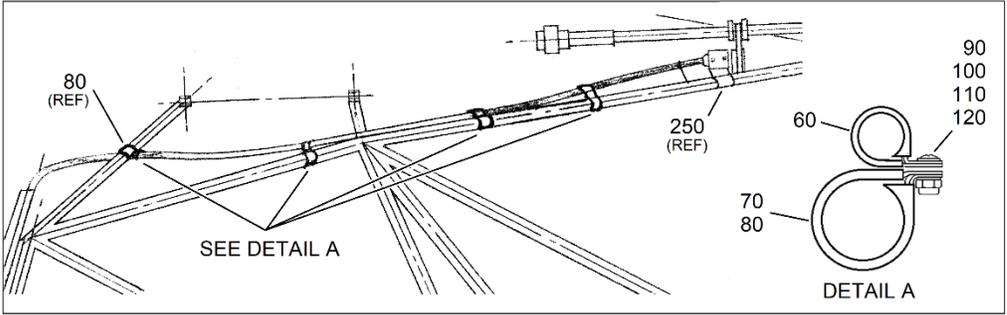
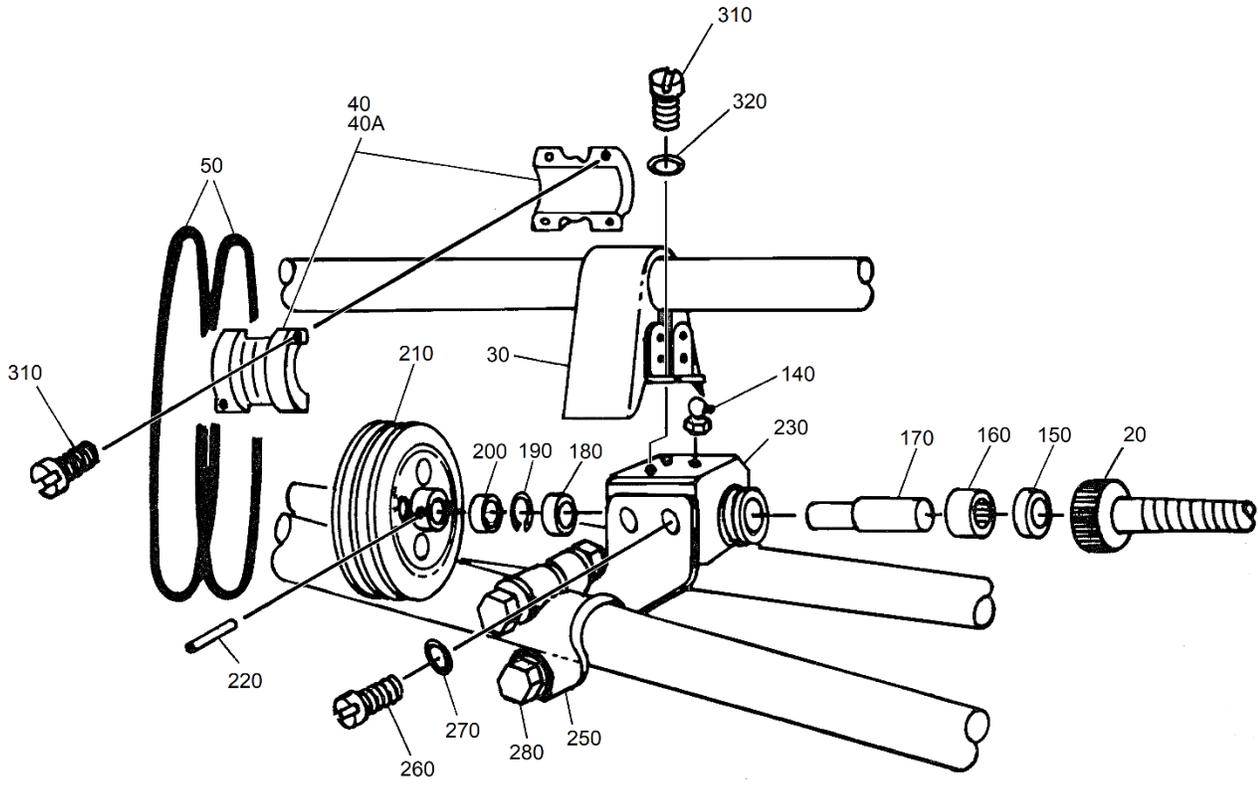

FIGURE 12-4. ROTOR TACHOMETER ASSEMBLY

ENSTROM F-28/280 SERIES ILLUSTRATED PARTS CATALOG

FIGURE 12-4. ROTOR TACHOMETER ASSEMBLY

ITEM NUMBER	PART NUMBER	DESCRIPTION	QTY PER ASSY	MODELS AFFECTED						
				F-28A	280	F-28C	280C	F-28F	280F	280FX
-10	28-18020-1	Tach Drive Assembly	REF	X	X			X	X	X
-10A	28-18020-3	Tach Drive Assembly (Inactive)	REF			X	X			
20	ECD108-3	. Rotor Tach Cable	1	X	X	X	X	X	X	X
20	12528Y-A164	. Rotor Tach Cable (Superseded by ECD108-3)	1	X	X	X	X	X	X	X
30*	28-18031-3	. Cover	1	X	X	X	X	X	X	X
30	28-18031-1	. Cover (Replaced by 28-18031-3)	1	X	X	X	X	X	X	X
40	28-18027-1	. Driver Pulley	1	X	X			X	X	X
40A	28-180010-11	. Driver Pulley (Inactive)	1			X	X			
50	NAS1611-333A	. O-Ring	2	X	X	X	X	X	X	X
60	MS21919WDG-5	. Clamp	4	X	X	X	X	X	X	X
70	MS21919WDG-14	. Clamp	3	X	X	X	X	X	X	X
80	MS21919WDG-12	. Clamp	1	X	X	X	X	X	X	X
90	MS35206-245	. Screw	4	X	X	X	X	X	X	X
90	AN515-8R8	. Screw (Superseded by MS35206-245)	4	X	X	X	X	X	X	X
100	NAS1149FN832P	. Washer	8	X	X	X	X	X	X	X
100	AN960-8	. Washer (Alternate)	8	X	X	X	X	X	X	X
110	AN935-8	. Lock Washer	4	X	X	X	X	X	X	X
120	MS35649-282	. Nut	4	X	X	X	X	X	X	X
120	AN340-832	. Nut (Superseded by MS35649-282)	4	X	X	X	X	X	X	X
-130	28-18020-5	. Tach Assembly	REF	X	X	X	X	X	X	X
140	1911-B1	. . Lube Fitting	1	X	X	X	X	X	X	X
150	1886	. . Seal, Type TC	1	X	X	X	X	X	X	X
150	B-44-28-2	. . Seal, Type B (Alternate)	1	X	X	X	X	X	X	X
160	B-710	. . Bearing	1	X	X	X	X	X	X	X

ENSTROM F-28/280 SERIES ILLUSTRATED PARTS CATALOG

FIGURE 12-4. ROTOR TACHOMETER ASSEMBLY

ITEM NUMBER	PART NUMBER	DESCRIPTION	QTY PER ASSY	MODELS AFFECTED						
				F-28A	280	F-28C	280C	F-28F	280F	280FX
170	28-18024-5	. . Shaft Assembly	1	X	X	X	X	X	X	X
170	28-18024-1	. . Shaft Assembly (Superseded by 28-18024-5)	1	X	X	X	X	X	X	X
180	ECD066-1	. . Bearing	1	X	X	X	X	X	X	X
190	N5000-62-PP	. . Snap Ring	1	X	X	X	X	X	X	X
200	28-18034-1	. . Spacer	1	X	X	X	X	X	X	X
210	28-18030-1	. . Driven Pulley	1	X	X	X	X	X	X	X
220	79012-062-0500	. . Roll Pin	1	X	X	X	X	X	X	X
230	28-18026-3	. . Tach Housing, Output	1	X	X	X	X	X	X	X
230	28-18026-1	. . Tach Housing, Output (Superseded by 28-18026-3)	1	X	X	X	X	X	X	X
-240	28-18020-7	. Tach and Bracket Assembly	REF	X	X	X	X	X	X	X
250	28-18028-1	. . Tach Bracket	1	X	X	X	X	X	X	X
260	NK501-10-6	. . Screw	4	X	X	X	X	X	X	X
260	NP501-10-6	. . Screw (Alternate)	4	X	X	X	X	X	X	X
270	NAS1149F0363P	. . Washer	4	X	X	X	X	X	X	X
270	AN960-10	. . Washer (Alternate)	4	X	X	X	X	X	X	X
280	NAS6603-12	. . Bolt	4	X	X	X	X	X	X	X
280	AN3-11A	. . Bolt (Superseded by NAS6603-12)	4	X	X	X	X	X	X	X
-290	NAS1149F0363P	. . Washer	8	X	X	X	X	X	X	X
-300	MS21044N3	. . Nut	4	X	X	X	X	X	X	X
310	NK500-8-X	. Screw (Length A/R)	6	X	X	X	X	X	X	X
310	NP500-8-X	. Screw (Length A/R) (Alternate)	6	X	X	X	X	X	X	X
320	NAS1149FN832P	. Washer	2	X	X	X	X	X	X	X
320	AN960-8	. Washer (Alternate)	2	X	X	X	X	X	X	X

* Effective F-28F S/N 883 and subsequent, 280FX S/N 2147 and subsequent. Eligibility all S/N.

ENSTROM F-28/280 SERIES ILLUSTRATED PARTS CATALOG

I

INTENTIONALLY LEFT BLANK

ENSTROM F-28/280 SERIES ILLUSTRATED PARTS CATALOG

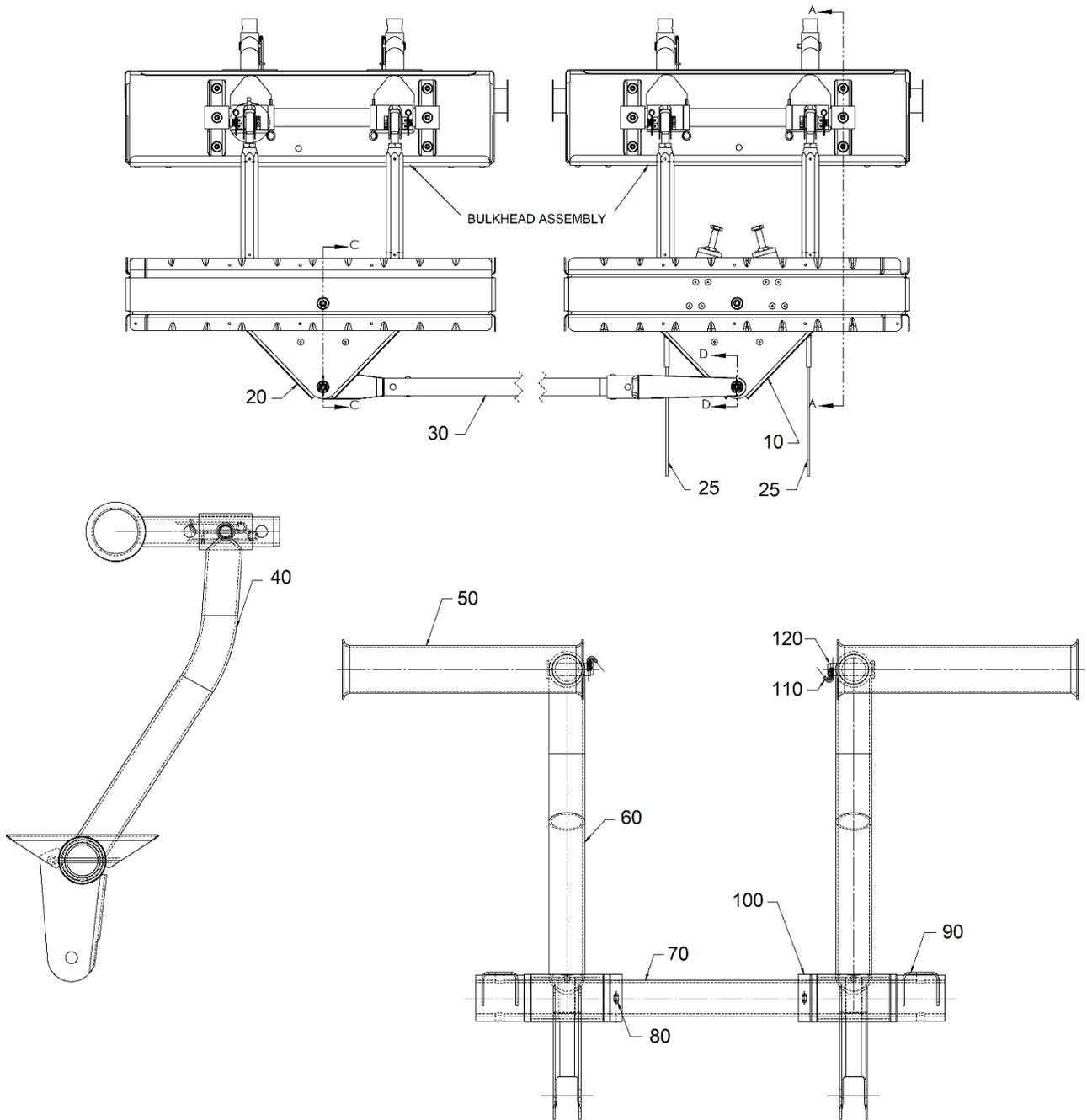

FIGURE 12-5. TAIL ROTOR BLADE CONTROL INSTALLATION

ENSTROM F-28/280 SERIES ILLUSTRATED PARTS CATALOG

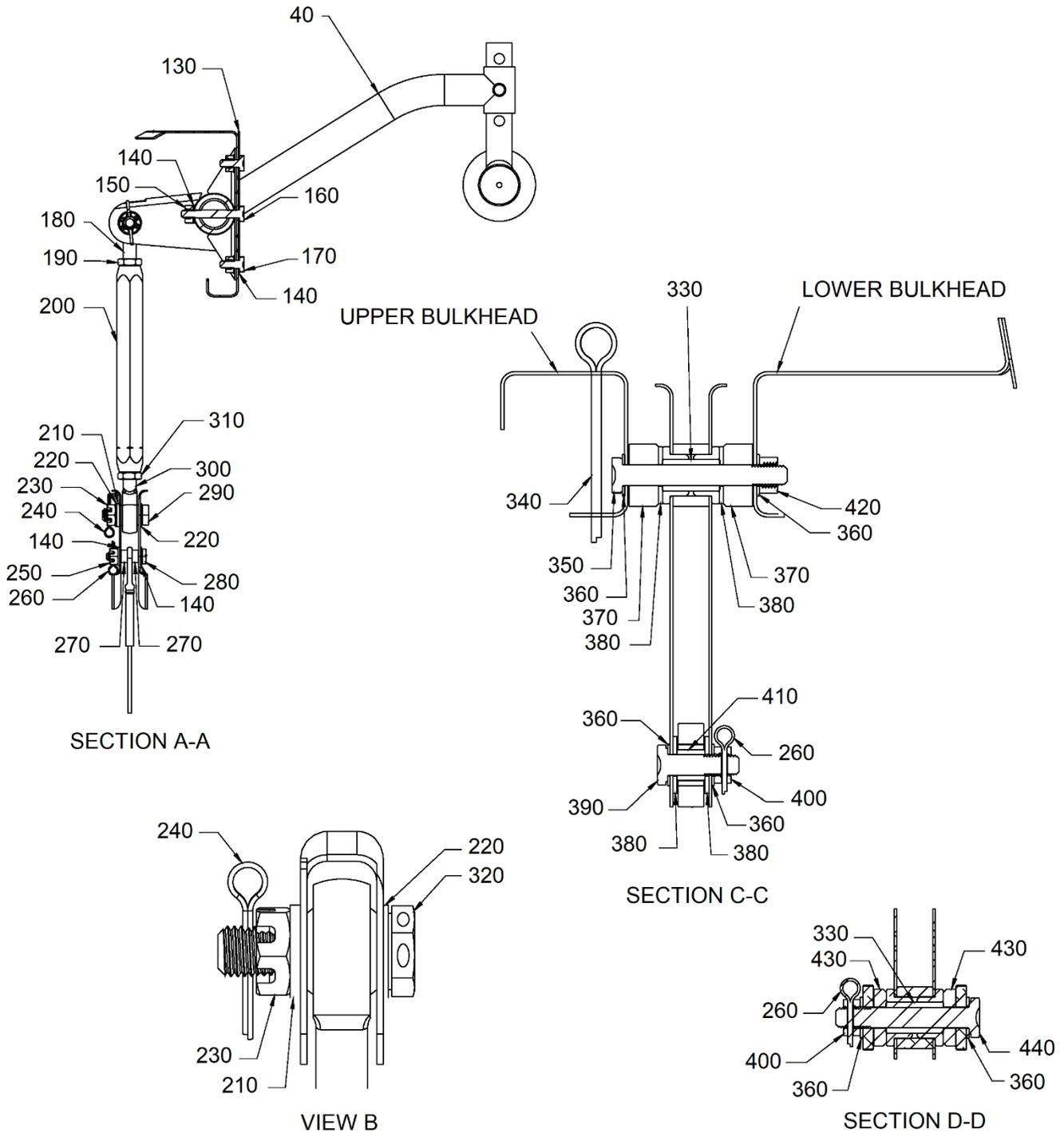
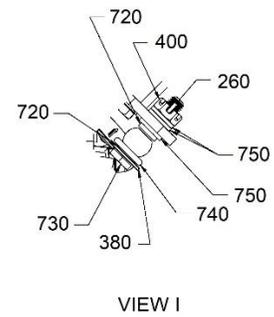
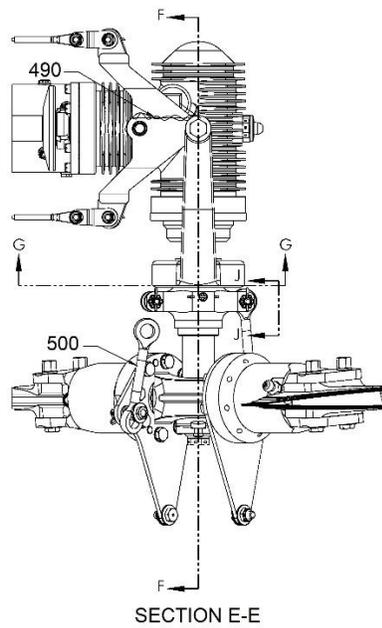
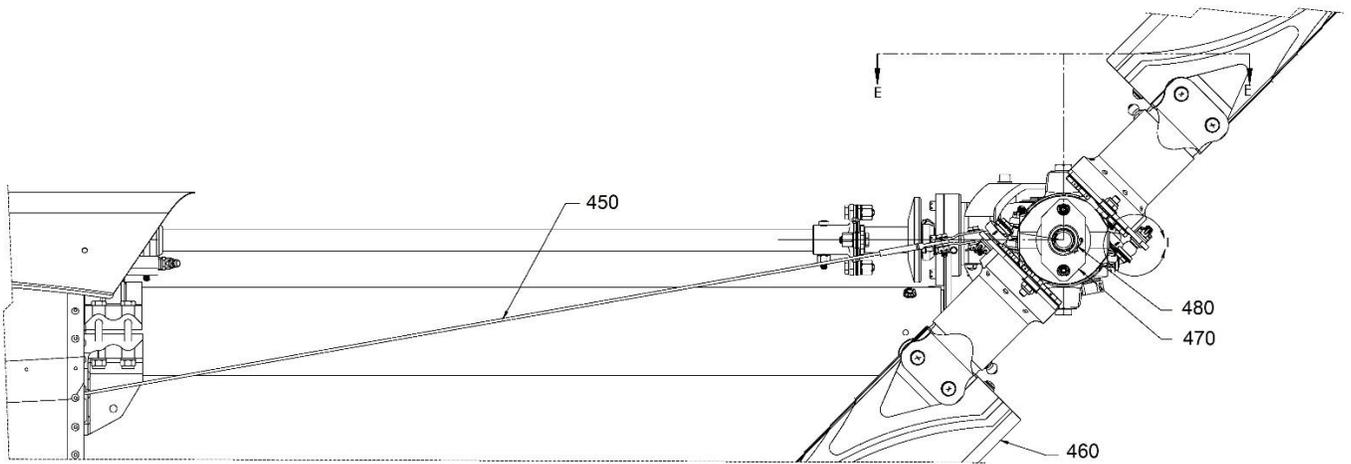

FIGURE 12-5. TAIL ROTOR BLADE CONTROL INSTALLATION

ENSTROM F-28/280 SERIES ILLUSTRATED PARTS CATALOG



Sheet 3 of 6

FIGURE 12-5. TAIL ROTOR BLADE CONTROL INSTALLATION

ENSTROM F-28/280 SERIES ILLUSTRATED PARTS CATALOG

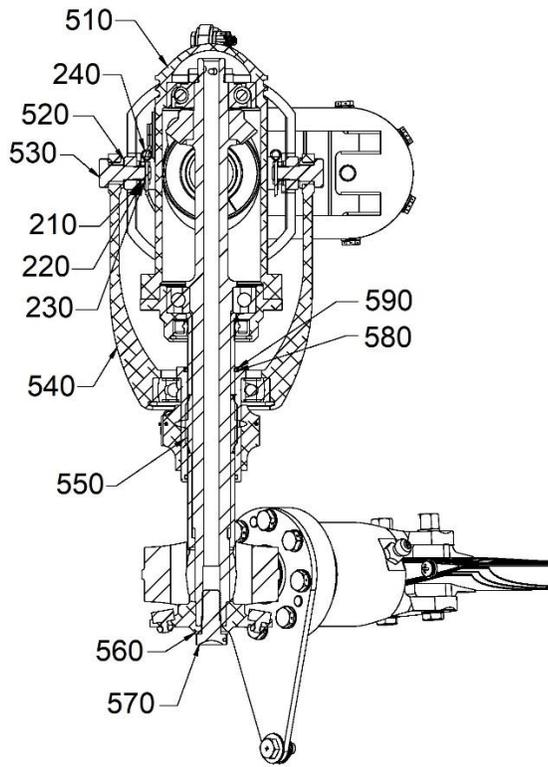

SECTION F-F

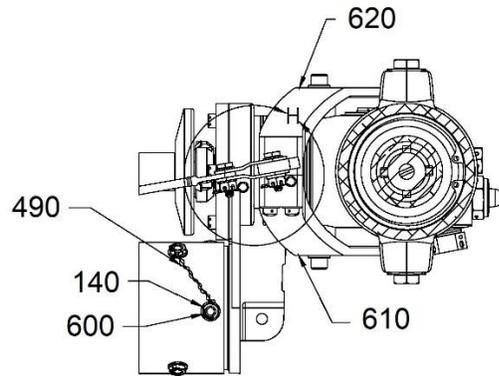

SECTION G-G

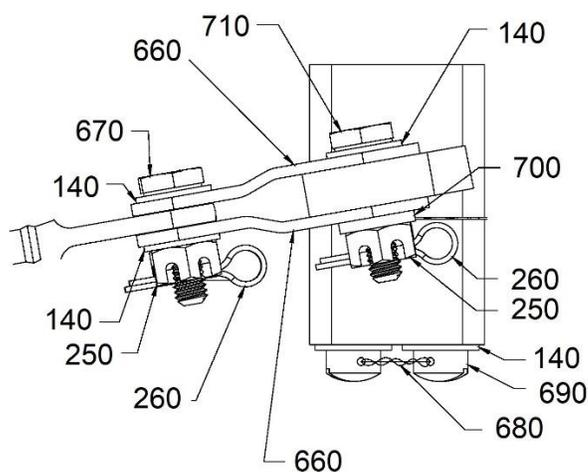
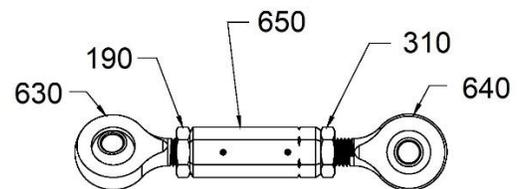

VIEW H

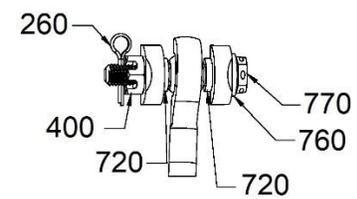

SECTION J-J

FIGURE 12-5. TAIL ROTOR BLADE CONTROL INSTALLATION

ENSTROM F-28/280 SERIES ILLUSTRATED PARTS CATALOG

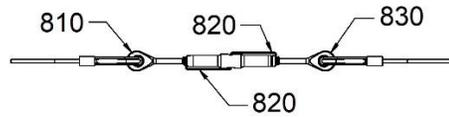
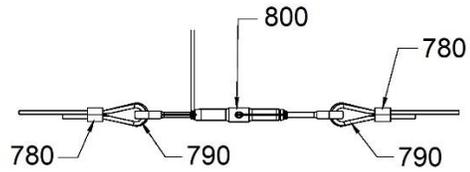
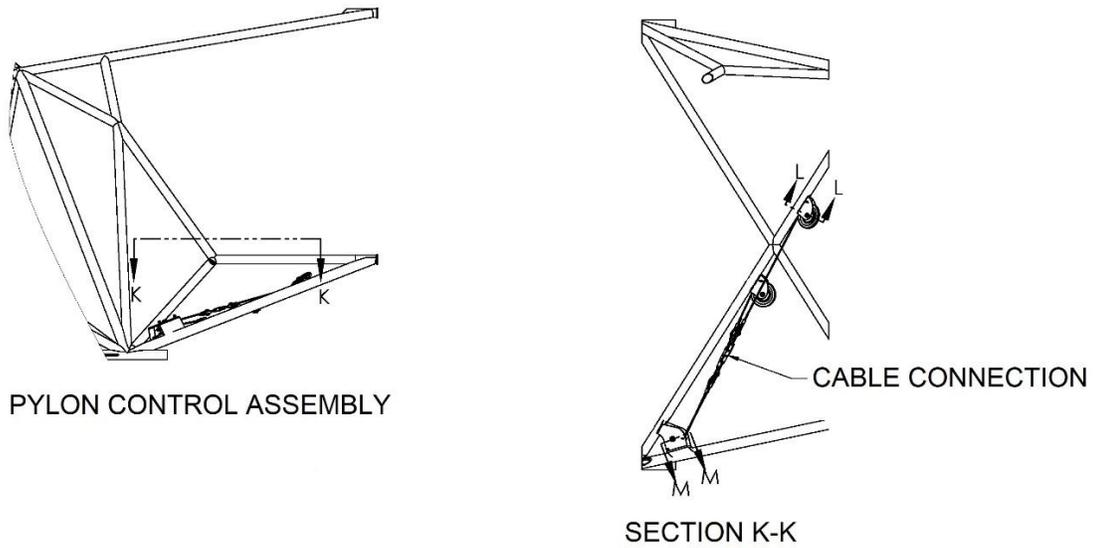

CABLE CONNECTION (2 PLACES)

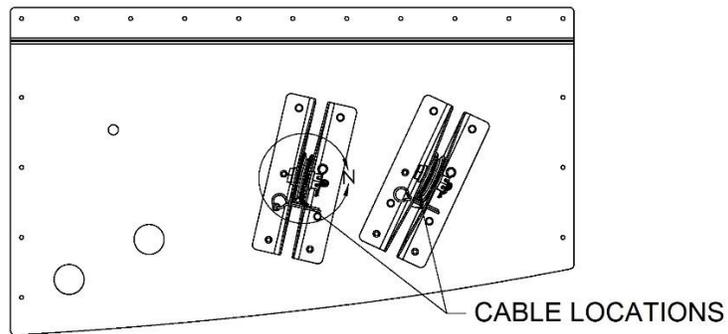

VIEW SHOWING PULLEYS IN SEAT STRUCTURE

FIGURE 12-5. TAIL ROTOR BLADE CONTROL INSTALLATION

ENSTROM F-28/280 SERIES ILLUSTRATED PARTS CATALOG

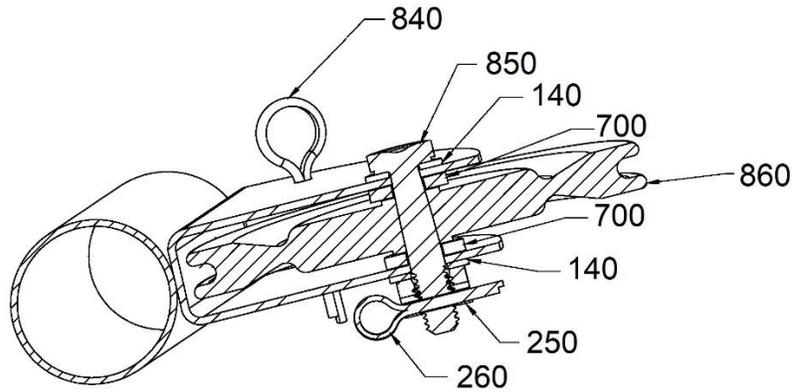

SECTION L-L

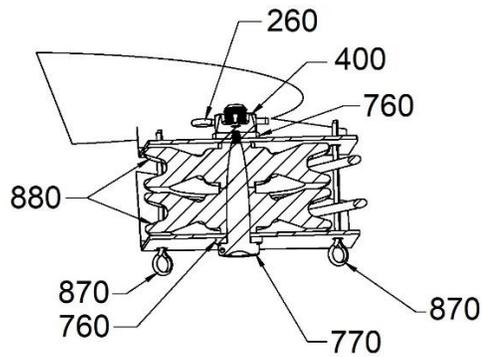

SECTION M-M

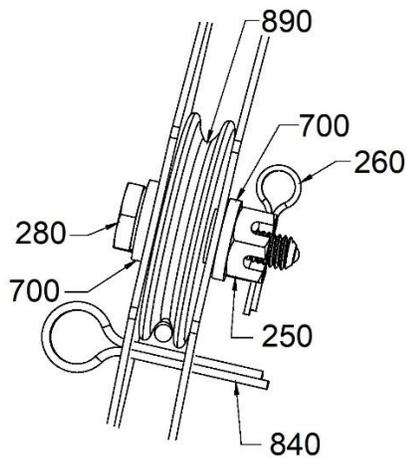

VIEW N

FIGURE 12-5. TAIL ROTOR BLADE CONTROL INSTALLATION

ENSTROM F-28/280 SERIES ILLUSTRATED PARTS CATALOG

FIGURE 12-5. TAIL ROTOR BLADE CONTROL INSTALLATION

ITEM NUMBER	PART NUMBER	DESCRIPTION	QTY PER ASSY	MODELS AFFECTED						
				F-28A	280	F-28C	280C	F-28F	280F	280FX
–	28-16398-103	Tail Rotor Blade Control Installation	REF	X	X	X	X	X	X	X
10	28-16338-1	. Bellcrank Assembly	1	X	X	X	X	X	X	X
–	28-16153-1	.. Spacer	2	X	X	X	X	X	X	X
–	28-16156-1	.. Bushing	4	X	X	X	X	X	X	X
–	28-16338-3	.. Bellcrank	2	X	X	X	X	X	X	X
–	28-16338-5	.. Stop Block	2	X	X	X	X	X	X	X
–	MS20470AD4-11	.. Rivet	12	X	X	X	X	X	X	X
20	28-16338-2	. Bellcrank Assembly	1	X	X	X	X	X	X	X
–	28-16153-1	.. Spacer	1	X	X	X	X	X	X	X
–	28-16156-1	.. Bushing	2	X	X	X	X	X	X	X
–	28-16338-5	.. Stop Block	2	X	X	X	X	X	X	X
–	28-16338-7	.. Bellcrank	2	X	X	X	X	X	X	X
–	MS20470AD4-11	.. Rivet	12	X	X	X	X	X	X	X
25	4150008-5	. Cable Assembly	2	X	X	X	X	X	X	X
30	28-16339-1	. Tie Rod Assembly	1	X	X	X	X	X	X	X
–	28-16339-3	.. Bushing Oilite		X	X	X	X	X	X	X
–	28-16339-4	.. Flat End Fitting		X	X	X	X	X	X	X
–	28-16339-5	.. Tube		X	X	X	X	X	X	X
–	28-16339-6	.. Filler Plug		X	X	X	X	X	X	X
–	28-16339-7	.. Forked End Fitting		X	X	X	X	X	X	X
–	MS20470AD4-19	.. Rivet		X	X	X	X	X	X	X
40*◆	28-16334-1	. Tail Rotor Control Pedal Assembly	2	X	X	X	X	X	X	X
–40A**	28-16334-5	. Tail Rotor Control Pedal Assembly (Removable)	A/R	X	X	X	X	X	X	X
–40B†▼	28-16334-7	. Tail Rotor Control Pedal Assembly	A/R	X	X	X	X	X	X	X
–40C△	28-16334-9	. Tail Rotor Control Pedal Assembly (Removable)	A/R	X	X	X	X	X	X	X
50	28-16322-7	.. Foot Support Assembly (Used with 28-16334-1 and 28-16334-5)	2	X	X	X	X	X	X	X

ENSTROM F-28/280 SERIES ILLUSTRATED PARTS CATALOG

FIGURE 12-5. TAIL ROTOR BLADE CONTROL INSTALLATION

ITEM NUMBER	PART NUMBER	DESCRIPTION	QTY PER ASSY	MODELS AFFECTED						
				F-28A	280	F-28C	280C	F-28F	280F	280FX
50	28-16322-1	. . Foot Support Assembly (Replaced by 28-16322-7)	2	X	X	X	X	X	X	X
-50A	28-16322-9	. . Foot Support Assembly (Used with 28-16334-7 and 28-16334-9)	2	X	X	X	X	X	X	X
60	28-16321-1	. . Pedal Leg Assembly (Used with 28-16334-1)	2	X	X	X	X	X	X	X
-60A	28-16321-101	. . Pedal Leg (Removable) (Used with 28-16334-5)	2	X	X	X	X	X	X	X
-60B	28-16321-103	. . Pedal Leg (Removable) (Used with 28-16334-9)	2	X	X	X	X	X	X	X
-60C	28-16321-105	. . Pedal Leg Assembly (Used with 28-16334-7)	2	X	X	X	X	X	X	X
70	28-16334-3	. . Shaft	1	X	X	X	X	X	X	X
80	MS24665-304	. . Cotter Pin	2	X	X	X	X	X	X	X
90	28-16355-1	. . Support Bushing Assembly	2	X	X	X	X	X	X	X
100	28-16341-1	. . Spacer	2	X	X	X	X	X	X	X
110	AN416-1	. . Pin - Retaining Safety	2	X	X	X	X	X	X	X
120	MS20392-3C25	. . Clevis Pin	2	X	X	X	X	X	X	X
130	28-11392-1	. Shield	4	X	X	X	X	X	X	X
-	#1357	. Adhesive	A/R	X	X	X	X	X	X	X
140	NAS1149F0332P	. Washer	48	X	X	X	X	X	X	X
150	MS21083N3	. Nut	12	X	X	X	X	X	X	X
160	NAS6603-17	. Bolt	4	X	X	X	X	X	X	X
170	NAS6603-2	. Bolt	8	X	X	X	X	X	X	X
180 [∞]	HMLVV5M	. Rod End	4	X	X	X	X	X	X	X
190	AN316-5L	. Nut	4	X	X	X	X	X	X	X
-	VC-3	. Thread Locker	A/R	X	X	X	X	X	X	X
200	28-16154-1	. Push-Pull Rod	4	X	X	X	X	X	X	X
210	NAS1149F0563P	. Washer	10	X	X	X	X	X	X	X
220	NAS1149F0532P	. Washer	14	X	X	X	X	X	X	X
230	MS17826-5	. Nut	10	X	X	X	X	X	X	X
240	MS24665-153	. Cotter Pin	10	X	X	X	X	X	X	X

ENSTROM F-28/280 SERIES ILLUSTRATED PARTS CATALOG

FIGURE 12-5. TAIL ROTOR BLADE CONTROL INSTALLATION

ITEM NUMBER	PART NUMBER	DESCRIPTION	QTY PER ASSY	MODELS AFFECTED						
				F-28A	280	F-28C	280C	F-28F	280F	280FX
250	MS17825-3	. Nut	10	X	X	X	X	X	X	X
260	MS24665-151	. Cotter Pin	17	X	X	X	X	X	X	X
270	28-16349-1	. Spacer	4	X	X	X	X	X	X	X
280	NAS6603D8	. Bolt	4	X	X	X	X	X	X	X
290	NAS6205-8D	. Bolt	4	X	X	X	X	X	X	X
300	HMVV5M	. Rod End	4	X	X	X	X	X	X	X
310	AN316-5R	. Nut	4	X	X	X	X	X	X	X
320	NAS6605D9	. Bolt	4	X	X	X	X	X	X	X
330	28-16157-3	. Spacer	3	X	X	X	X	X	X	X
340	MS24665-377	. Cotter Pin	2	X	X	X	X	X	X	X
350	NAS6604-25	. Bolt	2	X	X	X	X	X	X	X
360	NAS1149F0432P	. Washer	8	X	X	X	X	X	X	X
370	28-16342-1	. Spacer	4	X	X	X	X	X	X	X
380	ECD050-11	. Washer	8	X	X	X	X	X	X	X
390	NAS6604D7	. Bolt	1	X	X	X	X	X	X	X
400	MS17825-4	. Nut	7	X	X	X	X	X	X	X
410	28-16348-1	. Spacer	1	X	X	X	X	X	X	X
420	MS21083N4	. Nut	2	X	X	X	X	X	X	X
430	28-16340-1	. Spacer	2	X	X	X	X	X	X	X
440	NAS6604D19	. Bolt	1	X	X	X	X	X	X	X
450	28-16351-1	. Cable Eye Assembly	2	X	X	X	X	X	X	X
-	MS20668-3	. . Eye End	1	X	X	X	X	X	X	X
460	28-150079-5	. Rotor Assembly	1	X	X	X	X	X	X	X
470	28-15030-1	. Teetering Stop Assembly	1	X	X	X	X	X	X	X
-	MS21083N06	. . Nut	2	X	X	X	X	X	X	X
-	28-15028-1	. . Mount Plate	1	X	X	X	X	X	X	X
-	16-1	. . Bumper	2	X	X	X	X	X	X	X
480	MS20995-C41	. Safety Wire	A/R	X	X	X	X	X	X	X
490	MS20995-C32	. Safety Wire	A/R	X	X	X	X	X	X	X
500	28-16391-5	. Pitch Link Assembly	2	X	X	X	X	X	X	X

ENSTROM F-28/280 SERIES ILLUSTRATED PARTS CATALOG

FIGURE 12-5. TAIL ROTOR BLADE CONTROL INSTALLATION

ITEM NUMBER	PART NUMBER	DESCRIPTION	QTY PER ASSY	MODELS AFFECTED						
				F-28A	280	F-28C	280C	F-28F	280F	280FX
-	ECD030-11	. . Bearing	2	X	X	X	X	X	X	X
-	28-16391-13	. . Pitch Link	1	X	X	X	X	X	X	X
510	28-13525-7	. Tail Rotor Gearbox Assembly	1	X	X	X	X	X	X	X
520	28-16308-1	. Washer	2	X	X	X	X	X	X	X
530	28-16310-2	. Bolt	2	X	X	X	X	X	X	X
540	28-16396-2	. Bearing and Retainer Assembly	1	X	X	X	X	X	X	X
-	W1819-020	. . Wave Spring Washer	2	X	X	X	X	X	X	X
-	TS-023	. . Seal	1	X	X	X	X	X	X	X
-	MS24665-155	. . Cotter Pin	2	X	X	X	X	X	X	X
-	5002-268-PP	. . Retaining Ring	1	X	X	X	X	X	X	X
-	ECD016-11	. . Bearing	1	X	X	X	X	X	X	X
-	28-16392-13	. . Retainer Pitch Link	1	X	X	X	X	X	X	X
-	28-16397-11	. . Pin	2	X	X	X	X	X	X	X
-	28-16394-11	. . Bearing	1	X	X	X	X	X	X	X
-	28-16331-1	. . Bearing Housing	1	X	X	X	X	X	X	X
550	28-16395-1	. Key	4	X	X	X	X	X	X	X
560	NAS1149F0763P	. Washer	1	X	X	X	X	X	X	X
570	NAS6607H5	. Bolt	1	X	X	X	X	X	X	X
580	TS-023	. Seal	1	X	X	X	X	X	X	X
590	28-16374-1	. Retainer	1	X	X	X	X	X	X	X
600	NAS6603H1	. Bolt	6	X	X	X	X	X	X	X
610	28-16314-1	. Control Bracket	1	X	X	X	X	X	X	X
620	28-16313-1	. Control Bracket	1	X	X	X	X	X	X	X
630	ECD030-11	. Rod End Bearing	1	X	X	X	X	X	X	X
640	01-691-04	. Rod End Bearing	1	X	X	X	X	X	X	X
650	28-16345-1	. Barrel	1	X	X	X	X	X	X	X
660	28-16352-1	. Control Link	4	X	X	X	X	X	X	X
670	NAS6603D5	. Bolt	2	X	X	X	X	X	X	X
680	MS20995-C25	. Safety Wire	A/R	X	X	X	X	X	X	X

ENSTROM F-28/280 SERIES ILLUSTRATED PARTS CATALOG

FIGURE 12-5. TAIL ROTOR BLADE CONTROL INSTALLATION

ITEM NUMBER	PART NUMBER	DESCRIPTION	QTY PER ASSY	MODELS AFFECTED						
				F-28A	280	F-28C	280C	F-28F	280F	280FX
690	AN503-10-18	. Screw	4	X	X	X	X	X	X	X
700	NAS1149F0363P	. Washer	10	X	X	X	X	X	X	X
710	NAS6603D7	. Bolt	2	X	X	X	X	X	X	X
720	28-16353-5	. Spacer	8	X	X	X	X	X	X	X
730	NAS6604D15	. Bolt	2	X	X	X	X	X	X	X
740	MS28775-111	. O-Ring	2	X	X	X	X	X	X	X
750	NAS1149C0463R	. Washer	6	X	X	X	X	X	X	X
760	NAS1149F0463P	. Washer	4	X	X	X	X	X	X	X
770	NAS6604D17	. Bolt	3	X	X	X	X	X	X	X
780●	428-3-VG	. Sleeve	4	X	X	X	X	X	X	X
780	18-2-G	. Sleeve (Replaced by 428-3-VG)	4	X	X	X	X	X	X	X
790	AN100C-4	. Thimble	4	X	X	X	X	X	X	X
800▲	MS21251-B3S	. Barrel	2	X	X	X	X	X	X	X
810	MS21255-3LS	. Eye End	2	X	X	X	X	X	X	X
820	MS21256-1	. Clip	4	X	X	X	X	X	X	X
830	MS21255-3RS	. Eye End	2	X	X	X	X	X	X	X
840	MS24665-300	. Cotter Pin	4	X	X	X	X	X	X	X
850	NAS6603D9	. Bolt	2	X	X	X	X	X	X	X
860	MS24566-2B	. Pulley	2	X	X	X	X	X	X	X
870	AN210-2B	. Pulley (Superseded by MS24566-2B)	2	X	X	X	X	X	X	X
870	MS24665-157	. Cotter Pin	2	X	X	X	X	X	X	X
880	MS24566-3B	. Pulley	2	X	X	X	X	X	X	X
880	AN210-3B	. Pulley (Superseded by MS24566-3B)	2	X	X	X	X	X	X	X
890	MS24566-1B	. Pulley	2	X	X	X	X	X	X	X
890	AN210-1B	. Pulley (Superseded by MS24566-1B)	2	X	X	X	X	X	X	X

* Preferred optional chrome installation on the pilot side.

◆ Acceptable alternate optional chrome installation on the co-pilot side per customer build order.

ENSTROM F-28/280 SERIES ILLUSTRATED PARTS CATALOG

- █ ** Preferred optional chrome installation on the co-pilot side.
- █ † Painted flat black preferred installation on the pilot side.
- █ ▼ Acceptable alternate on the co-pilot per customer build order.
- █ Δ Painted flat black preferred installation on the co-pilot side.
- █ ∞ ARTL5E rod end is an acceptable alternate.
- █ ● MS51844-83 sleeve is an acceptable alternate.
- █ ▲ MS21251-B3L barrel may be substituted for MS21251-B3S.

ENSTROM F-28/280 SERIES ILLUSTRATED PARTS CATALOG

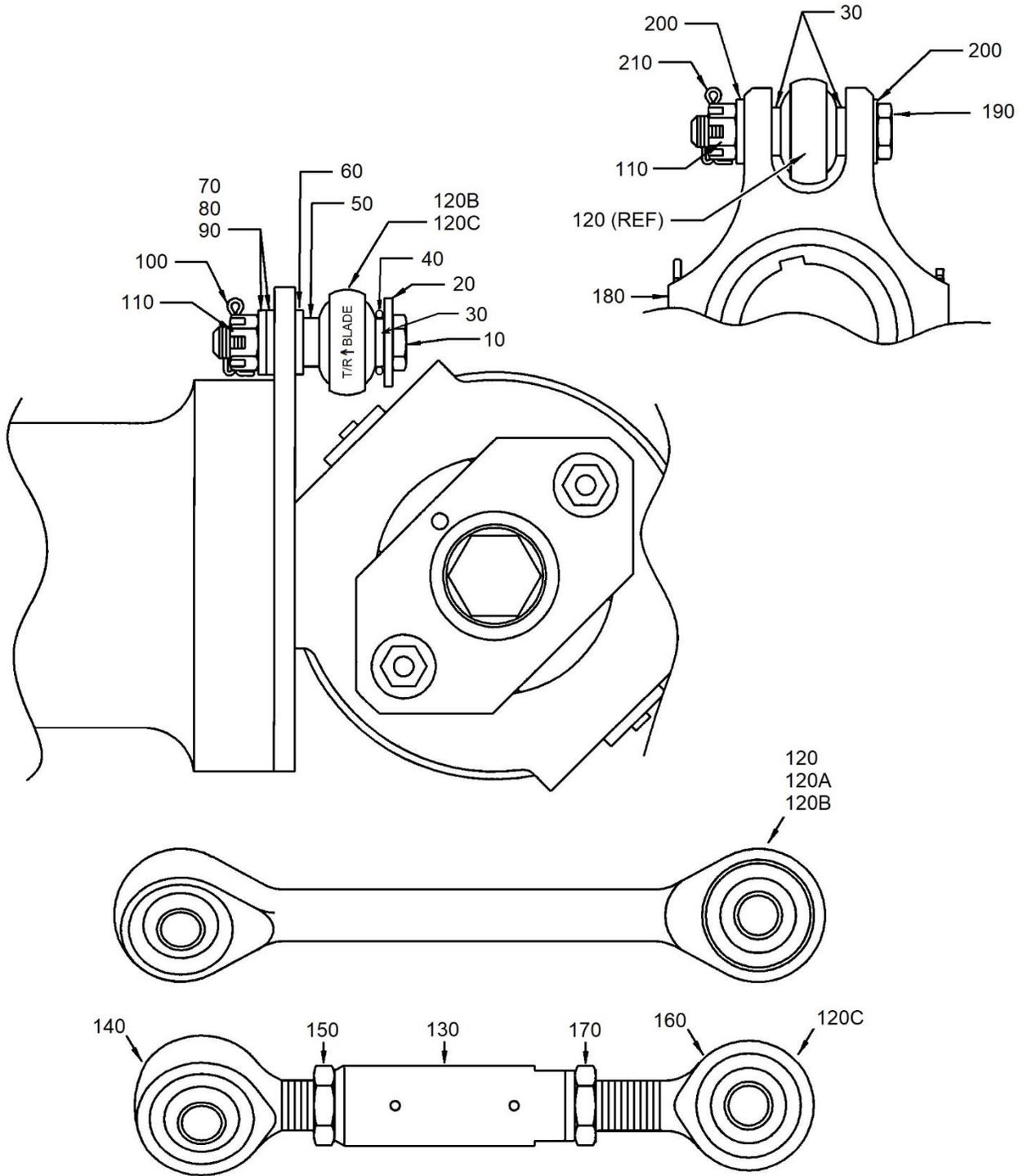

FIGURE 12-6. TAIL ROTOR PITCH LINK ASSEMBLY

ENSTROM F-28/280 SERIES ILLUSTRATED PARTS CATALOG

FIGURE 12-6. TAIL ROTOR PITCH LINK ASSEMBLY

ITEM NUMBER	PART NUMBER	DESCRIPTION	QTY PER ASSY	MODELS AFFECTED						
				F-28A	280	F-28C	280C	F-28F	280F	280FX
-5	28-16398	Tail Rotor Gear Box with Controls	REF	X	X	X	X	X	X	X
10	NAS6604D15	. Bolt	2	**	**	X	X	X	X	X
10	AN4-13	. Bolt (Superseded by NAS6604D15)	2	**	**	X	X	X	X	X
20	ECD050-11	. Washer	2	**	**	X	X	X	X	X
30	28-16353-5	. Spacer	6	**	**	X	X	X	X	X
40	MS28775-111	. O-Ring	2	**	**	X	X	X	X	X
50	28-16353-3	. Spacer	2	**	**	X	X	X	X	X
60	NAS1149C0463R	. Washer	2	**	**	X	X	X	X	X
60	AN960-416	. Washer (Do not use; Replaced by NAS1149C0463R)	2	**	**	X	X	X	X	X
70*	NAS1149C0463R	. Washer	A/R	**	**	X	X	X	X	X
70	AN960-416	. Washer (Do not use; Replaced by NAS1149C0463R)	A/R	**	**	X	X	X	X	X
80*	NAS1149C0432R	. Washer	A/R	**	**	X	X	X	X	X
90*	ECD050-11	. Washer	A/R	**	**	X	X	X	X	X
90*	1/4 Harper	. Washer (Superseded by ECD050-11)	A/R	**	**	X	X	X	X	X
100	MS24665-1013	. Cotter Pin	2	**	**	X	X	X	X	X
100	AN381-2-8	. Cotter Pin (Superseded by MS24665-1013)	2	**	**	X	X	X	X	X
110	MS17825-4	. Nut	4	**	**	X	X	X	X	X
110	F12NE4753-048	. Nut (Superseded by MS17825-4)	4	**	**	X	X	X	X	X
120‡	28-16391-5	. Tail Rotor Pitch Link Assembly (Preferred)	2	**	**	X	X	X	X	X
120A	28-16391-3	. Tail Rotor Pitch Link Assembly (Inactive)	2	**	**	X	X	X	X	X
120B	28-16391-1	. Tail Rotor Pitch Link Assembly (Inactive)	2	**	**	X	X	X	X	X
120C	28-16398-901	. Tail Rotor Pitch Link Assembly (Alternate)	2	X	X	X	X	X	X	X

ENSTROM F-28/280 SERIES ILLUSTRATED PARTS CATALOG

FIGURE 12-6. TAIL ROTOR PITCH LINK ASSEMBLY

ITEM NUMBER	PART NUMBER	DESCRIPTION	QTY PER ASSY	MODELS AFFECTED						
				F-28A	280	F-28C	280C	F-28F	280F	280FX
130	28-16345-1	. . Barrel	1	X	X	X	X	X	X	X
140	11-691-04	. . Rod End	1	X	X	X	X	X	X	X
150	AN316-5L	. . Nut	1	X	X	X	X	X	X	X
160	01-691-04	. . Rod End	1	X	X	X	X	X	X	X
170	AN316-5R	. . Nut	1	X	X	X	X	X	X	X
180	28-16392-13	. Pitch Change Retainer	1	X	X	X	X	X	X	X
190	NAS6604D17	. Bolt	2	X	X	X	X	X	X	X
190	AN4-14	. Bolt (Superseded by NAS6604D17)	2	X	X	X	X	X	X	X
200	NAS1149F0463P	. Washer	4	X	X	X	X	X	X	X
210	MS24665-151	. Cotter Pin	2	X	X	X	X	X	X	X
210	AN381-2-8	. Cotter Pin (Superseded by MS24665-151)	2	X	X	X	X	X	X	X

* As required for balance.

** Eligible on F-28A and 280 models if updated to left side tail rotor system in accordance with SIL 0159.

‡ Effectivity F-28F S/N 831 and subsequent and 280FX 2142 and subsequent. Retrofittable to F-28 series S/N 509 and subsequent and 280 series 2001 and subsequent.

ENSTROM F-28/280 SERIES ILLUSTRATED PARTS CATALOG

I

INTENTIONALLY LEFT BLANK

ENSTROM F-28/280 SERIES ILLUSTRATED PARTS CATALOG

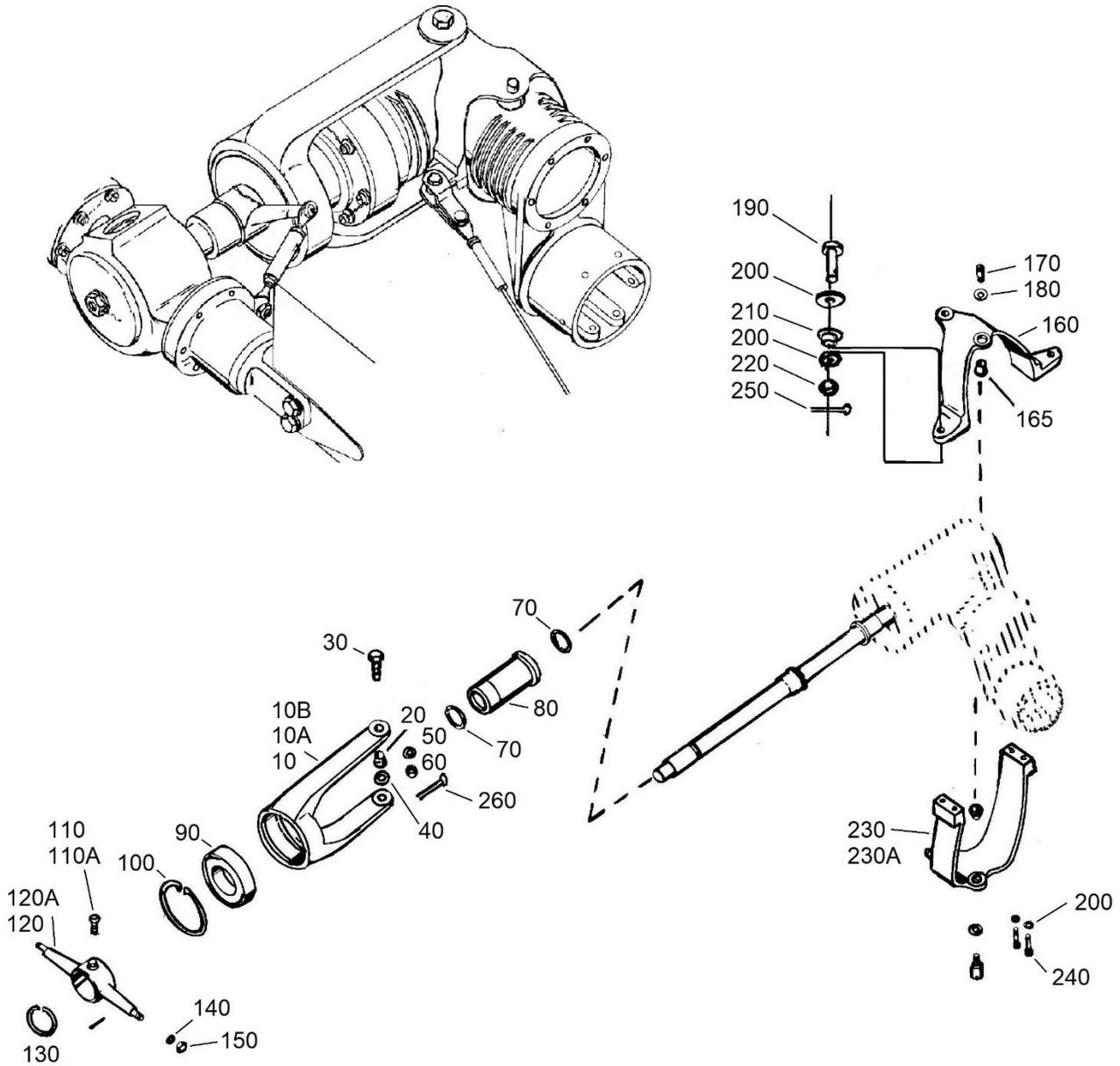

FIGURE 12-7. TAIL ROTOR MECHANICAL CONTROLS (RIGHT HAND GEARBOX)

ENSTROM F-28/280 SERIES ILLUSTRATED PARTS CATALOG

FIGURE 12-7. TAIL ROTOR MECHANICAL CONTROLS (RIGHT HAND GEARBOX)

ITEM NUMBER	PART NUMBER	DESCRIPTION	QTY PER ASSY	MODELS AFFECTED						
				F-28A	280	F-28C	280C	F-28F	280F	280FX
-5	28-16300	Tail Rotor Gearbox, Blades, and Controls Installation	REF	X	X					
10	28-16301-4	. Bearing Housing Assembly	1	X	X					
10A*	28-16301-7	. Bearing Housing Assembly	1	X	X					
10B	28-16331-1	. Bearing Housing Assembly	1	X	X					
20	28-16311-1	. Bushing	2	X	X					
30	28-16310-2	. Bolt	2	X	X					
40	28-16308-1	. Washer	2	X	X					
50	NAS1149F0532P	. Washer	2	X	X					
50	AN960-516L	. Washer (Alternate)	2	X	X					
-55	NAS1149F0563P	. Washer	2	X	X					
-55	AN960-516	. Washer (Alternate)	2	X	X					
60	MS17825-5	. Nut	2	X	X					
60	F12NE-4753-054	. Nut (Superseded by MS17825-5)	2	X	X					
70	TS-023	. Seal	2	X	X					
80	28-16302-1	. Bearing-Control, Pitch	1	X	X					
90	ECD016-11	. Bearing	1	X	X					
100	N5000-268-PP	. Snap Ring	1	X	X					
110	28-16307-1	. Bolt	2	X	X					
110A*	28-16324	. Bolt	2	X	X					
120	28-16320-1	. Retainer - Pitch Link	1	X	X					
120A*	28-16325-2	. Retainer - Pitch Link	1	X	X					
130	5102-137-PP	. Snap Ring	1	X	X					
140	ECD050-11	. Washer	2	X	X					
140	1/4 Harper	. Washer (1/4 ID x 11/16 OD x .050) (Superseded by ECD050-11)	2	X	X					

ENSTROM F-28/280 SERIES ILLUSTRATED PARTS CATALOG

FIGURE 12-7. TAIL ROTOR MECHANICAL CONTROLS (RIGHT HAND GEARBOX)

ITEM NUMBER	PART NUMBER	DESCRIPTION	QTY PER ASSY	MODELS AFFECTED						
				F-28A	280	F-28C	280C	F-28F	280F	280FX
150	MS17825-4	. Nut	2	X	X					
150	F12NE-4753-048	. Nut (Superseded by MS17825-4)	2	X	X					
160**▲	28-16313-1	. Bracket	1	X	X					
160A**†	28-16317-1R	. Bracket	1	X	X					
165	28-16311-1	. Bushing	2	X	X					
170	28-16309-1	. Bolt	2	X	X					
180	28-16308-1	. Washer	2	X	X					
190	NAS6603D6	. Bolt	2	X	X					
190	AN3-6	. Bolt (Superseded by NAS6603D6)	2	X	X					
200	NAS1149F0332P	. Washer	8	X	X					
200	AN960-10L	. Washer (Alternate)	8	X	X					
210	28-16319-1	. Bushing (Used in Item 160)	2	X	X					
220	MS17825-3	. Nut	2	X	X					
220	F12NE-4753-02	. Nut (Superseded by MS17825-3)	2	X	X					
230**▲	28-16314-1	. Bracket	1	X	X					
230A**†	28-16315-1R	. Bracket	1	X	X					
240	AN503-10-8	. Screw	4	X	X					
250	MS24665-151	. Cotter Pin	6	X	X					
250	AN381-2-8	. Cotter Pin (Superseded by MS24665-151)	6	X	X					

– Not illustrated.

* Preferred components.

** 28-16315-1R and 28-16317-1R may be replaced on F28A, 280, and early "C" models with 28-16314-1 and 28-16313-1 (-110A and -120A are used together -110 and -120 are used together).

▲ Must be replaced/purchased as a matched set.

† Must be replaced/purchased as a matched set.

ENSTROM F-28/280 SERIES ILLUSTRATED PARTS CATALOG

I

INTENTIONALLY LEFT BLANK

ENSTROM F-28/280 SERIES ILLUSTRATED PARTS CATALOG

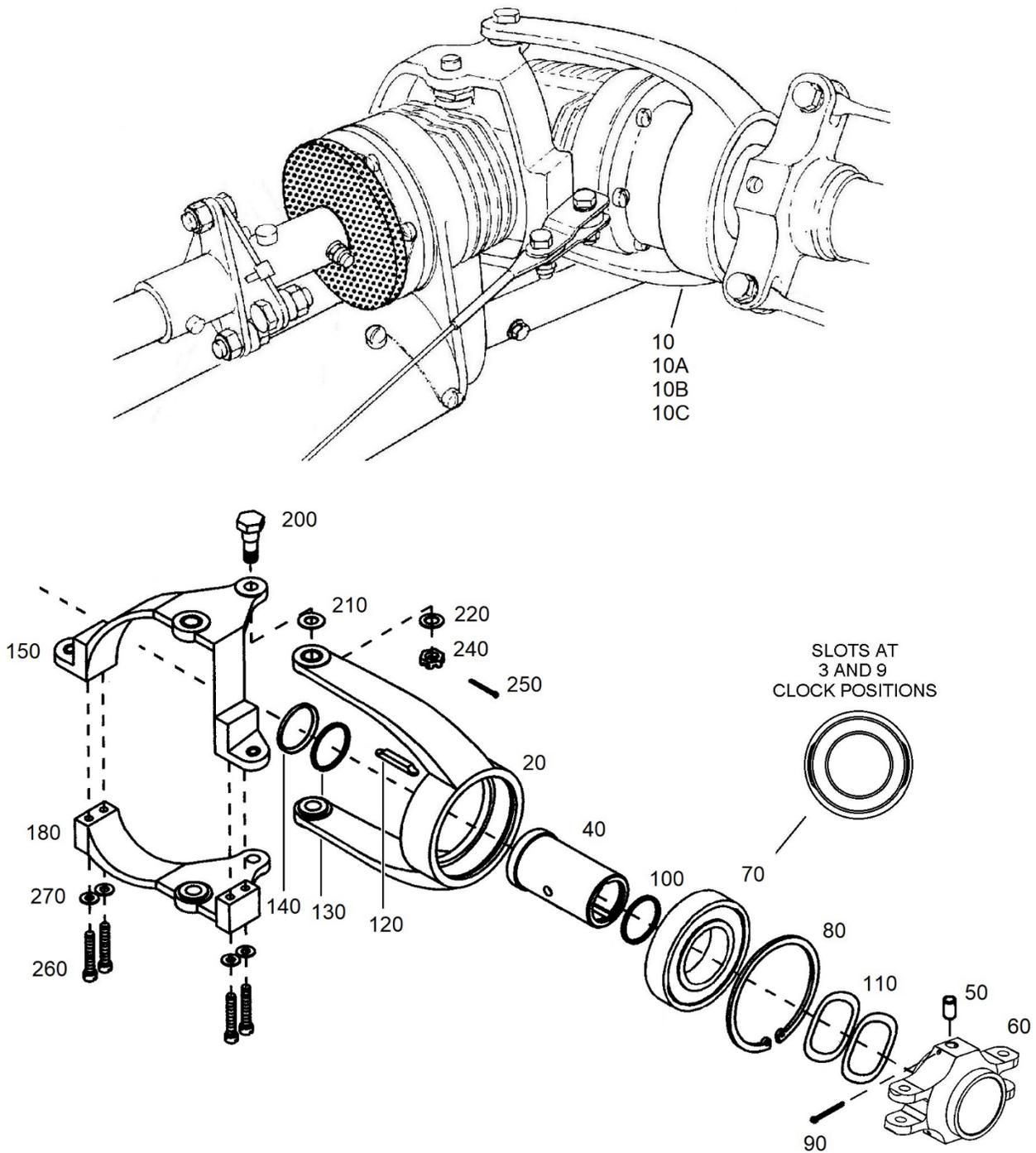

FIGURE 12-8. TAIL ROTOR MECHANICAL CONTROLS (LEFT HAND GEARBOX)

ENSTROM F-28/280 SERIES ILLUSTRATED PARTS CATALOG

FIGURE 12-8. TAIL ROTOR MECHANICAL CONTROLS (LEFT HAND GEARBOX)

ITEM NUMBER	PART NUMBER	DESCRIPTION	QTY PER ASSY	MODELS AFFECTED						
				F-28A	280	F-28C	280C	F-28F	280F	280FX
-5	28-16398	Tail Rotor Gearbox, Blades, and Controls Installation	REF			X	X	X	X	X
-5A	28-16380	Tail Rotor Gearbox, Blades, and Controls Installation	REF	X	X	X	X			
10	28-16396-2	. Bearing Housing and Pitch Link Retainer Assembly	1	X	X	X	X	X	X	X
10A	28-16301-3	. Bearing Housing and Pitch Link Retainer Assembly	1	X	X	X	X			
10B	28-16301-4	. Bearing Housing and Pitch Link Retainer Assembly	1	X	X	X	X			
10C	28-16301-7	. Bearing Housing and Pitch Link Retainer Assembly	1	X	X	X	X			
20	28-16331-1	. . Bearing Housing Assembly	1	X	X	X	X	X	X	X
-30	28-16311-1	. . . Bushing	2	X	X	X	X	X	X	X
40	28-16394-2	. . Bearing	1	X	X	X	X	X	X	X
50	28-16397-11	. . Pin	2	X	X	X	X	X	X	X
60*	28-16392-13	. . Retainer, Pitch Link	1	*	*	X	X	X	X	X
70	ECD016-11	. . Bearing	1	X	X	X	X	X	X	X
80	N5002-268-PP	. . Retaining Ring	1	X	X	X	X	X	X	X
90	MS24665-155	. . Cotter Pin	2	X	X	X	X	X	X	X
90	AN381-2-16	. . Cotter Pin (Superseded by MS24665-155)	2	X	X	X	X	X	X	X
100	TS-023	. . Seal	1	X	X	X	X	X	X	X
110	W1819-020	. . Wave Spring Washer	2	X	X	X	X	X	X	X
120	28-16395-1	. Key	2	X	X	X	X	X	X	X
130	TS-023	. Seal	1	X	X	X	X	X	X	X
140	28-16374-1	. Seal Retainer	1	X	X	X	X	X	X	X
150	28-16313-1	. Control Bracket, Top	1	X	X	X	X	X	X	X
-160	28-16319-1	. . Bushing	2	X	X	X	X	X	X	X
-170	28-16311-1	. . Bushing	1	X	X	X	X	X	X	X
180	28-16314-1	. Control Bracket, Bottom	1	X	X	X	X	X	X	X
-190	28-16311-1	. . Bushing	1	X	X	X	X	X	X	X

ENSTROM F-28/280 SERIES ILLUSTRATED PARTS CATALOG

FIGURE 12-8. TAIL ROTOR MECHANICAL CONTROLS (LEFT HAND GEARBOX)

ITEM NUMBER	PART NUMBER	DESCRIPTION	QTY PER ASSY	MODELS AFFECTED						
				F-28A	280	F-28C	280C	F-28F	280F	280FX
200	28-16310-2	. Bolt	2	X	X	X	X	X	X	X
210	28-16308-1	. Washer	2	X	X	X	X	X	X	X
220	NAS1149F0532P	. Washer	2	X	X	X	X	X	X	X
220	AN960-516L	. Washer (Alternate)	2	X	X	X	X	X	X	X
-230	NAS1149F0563P	. Washer	2	X	X	X	X	X	X	X
-230	AN960-516	. Washer (Alternate)	2	X	X	X	X	X	X	X
240	MS17825-5	. Nut	2	X	X	X	X	X	X	X
240	F12NE-4753-054	. Nut (Superseded by MS17825-5)	2	X	X	X	X	X	X	X
250	MS24665-151	. Cotter Pin	2	X	X	X	X	X	X	X
250	AN381-2-10	. Cotter Pin (Superseded by MS24665-151)	2	X	X	X	X	X	X	X
260	AN503-10-18	. Screw	4	X	X	X	X	X	X	X
270	NAS1149F0332P	. Washer	4	X	X	X	X	X	X	X
270	AN960-10L	. Washer (Alternate)	4	X	X	X	X	X	X	X
-280	MS20995C20	. Safety Wire	A/R	X	X	X	X	X	X	X

- Not illustrated.

* Effective if converted to left side tail rotor installation in accordance with SIL 0159.

ENSTROM F-28/280 SERIES ILLUSTRATED PARTS CATALOG

I

INTENTIONALLY LEFT BLANK

ENSTROM F-28/280 SERIES ILLUSTRATED PARTS CATALOG

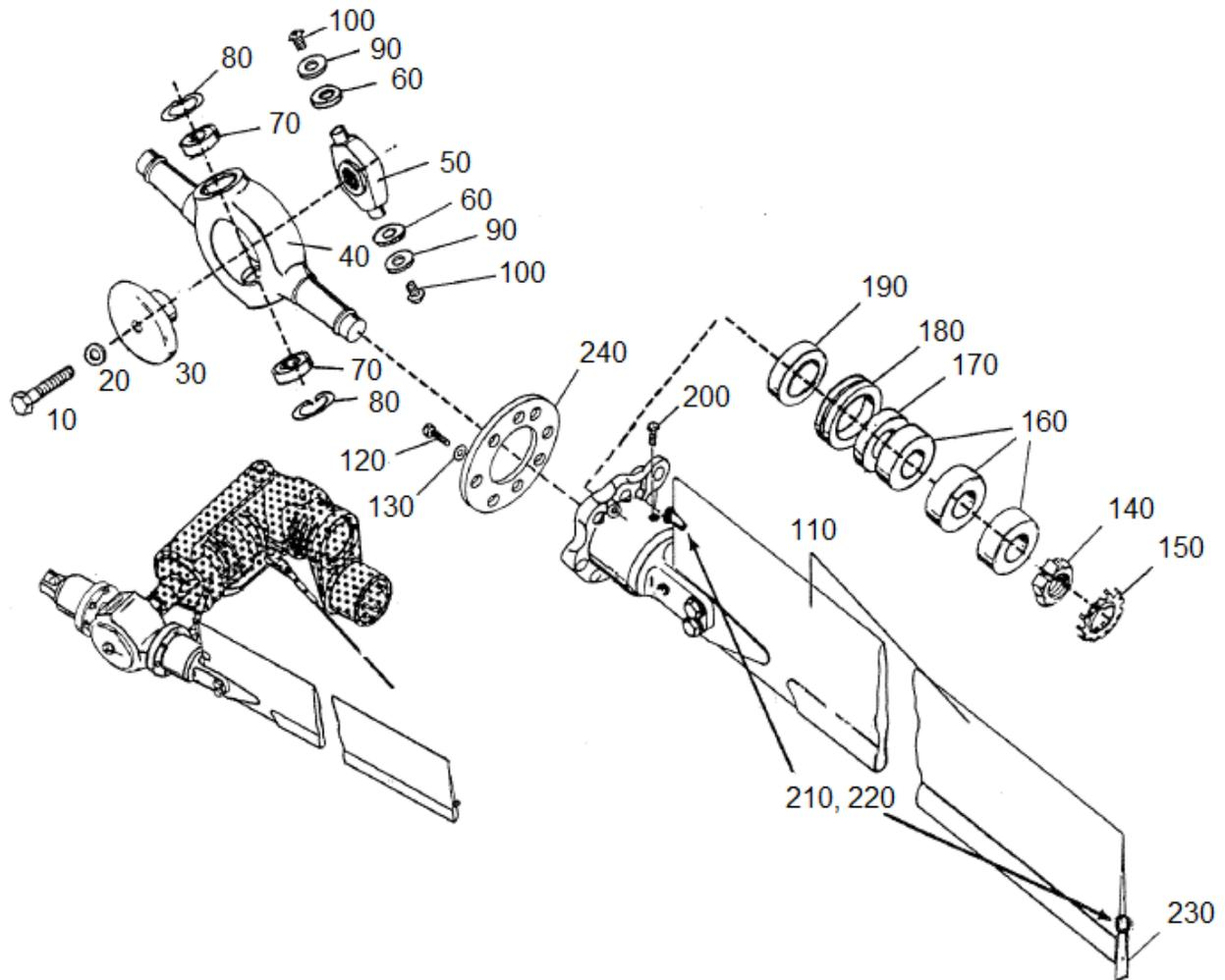

FIGURE 12-9. 28-15018-3 TAIL ROTOR ASSEMBLY

ENSTROM F-28/280 SERIES ILLUSTRATED PARTS CATALOG

FIGURE 12-9. 28-15018-3 TAIL ROTOR ASSEMBLY

ITEM NUMBER	PART NUMBER	DESCRIPTION	QTY PER ASSY	MODELS AFFECTED						
				F-28A	280	F-28C	280C	F-28F	280F	280FX
-	28-16300	Tail Rotor Blades, Gearbox, & Controls Installation	REF	X	X					
10	NAS6607-5	. Bolt	1	X	X					
10	AN7H-7A	. Bolt (Superseded by NAS6607-5)	1	X	X					
20	NAS1149F0763P	. Washer	1	X	X					
20	AN960-716	. Washer (Alternate)	1	X	X					
30	28-15002-1	. Teeter Stop	1	X	X					
-	28-15018-3	. Tail Rotor Assembly	1	X	X					
40	28-15202-13	.. Spindle	1	X	X					
50	28-15206-1	.. Hub	1	X	X					
60	28-15203-3	.. Shim, .001"	A/R	X	X					
60	28-15203-4	.. Shim, .002"	A/R	X	X					
60	28-15203-5	.. Shim, .003"	A/R	X	X					
60	28-15203-6	.. Shim, .005"	A/R	X	X					
70●	KRP8A-H	.. Bearing	2	X	X					
80*	N5000-112-PP	.. Snap Ring	2	X	X					
90	28-14120-11	.. Washer	2	X	X					
100	MS21262-6	.. Screw	2	X	X					
110†▲	28-15017-1	.. Blade and Grip Assembly	2	X	X					
120	NAS6604H1	.. Bolt	16	X	X					
120	AN4H-4A	.. Bolt (Superseded by NAS6604H1)	16	X	X					
130	NAS1149F0463P	.. Washer	16	X	X					
130	AN960-416	.. Washer	16	X	X					
140	SL1N-4	.. Nut	2	X	X					
150	SL61W-4	.. Lock Washer	2	X	X					
160◇	7203BTVPUO	.. Bearing Set (3 pc)	2	X	X					
160	ABEC-3	.. Bearing Set (3 pc) (Alternate)	2	X	X					
160	Q30203DT	.. Bearing Set (Replaced by 7203BTVPUO)	2	X	X					

ENSTROM F-28/280 SERIES ILLUSTRATED PARTS CATALOG

FIGURE 12-9. 28-15018-3 TAIL ROTOR ASSEMBLY

ITEM NUMBER	PART NUMBER	DESCRIPTION	QTY PER ASSY	MODELS AFFECTED						
				F-28A	280	F-28C	280C	F-28F	280F	280FX
170	28-15005-1	.. Spacer	2	X	X					
180◇	28-15027-10	.. Spacer	2	X	X					
190	KP-16B	.. Bearing	2	X	X					
200	AN526-1032-6	.. Screw	2	X	X					
-	1641	.. Lube Fitting	2	X	X					
210	MS35206-249	.. Screw	4	X	X					
210	AN515-8-16	.. Screw (Superseded by MS35206-249)	4	X	X					
220	NAS1149FN832P	.. Washer	A/R	X	X					
220	AN960-8	.. Washer (Alternate)	A/R	X	X					
230	28-17308-1	.. Strike Indicator	2	X	X					
240†▲	28-15013-1	.. Plate	2	X	X					

• Alternate is KP8A.

* Alternate is 28-14121-11.

† Item 110 and Item 240 are used together for right hand installation only.

▲ 28-150021-11 and 28-150023-1 are preferred replacement parts and for right or left hand installation.

◇ Available as Kit 28-01023-1.

ENSTROM F-28/280 SERIES ILLUSTRATED PARTS CATALOG

I

INTENTIONALLY LEFT BLANK

ENSTROM F-28/280 SERIES ILLUSTRATED PARTS CATALOG

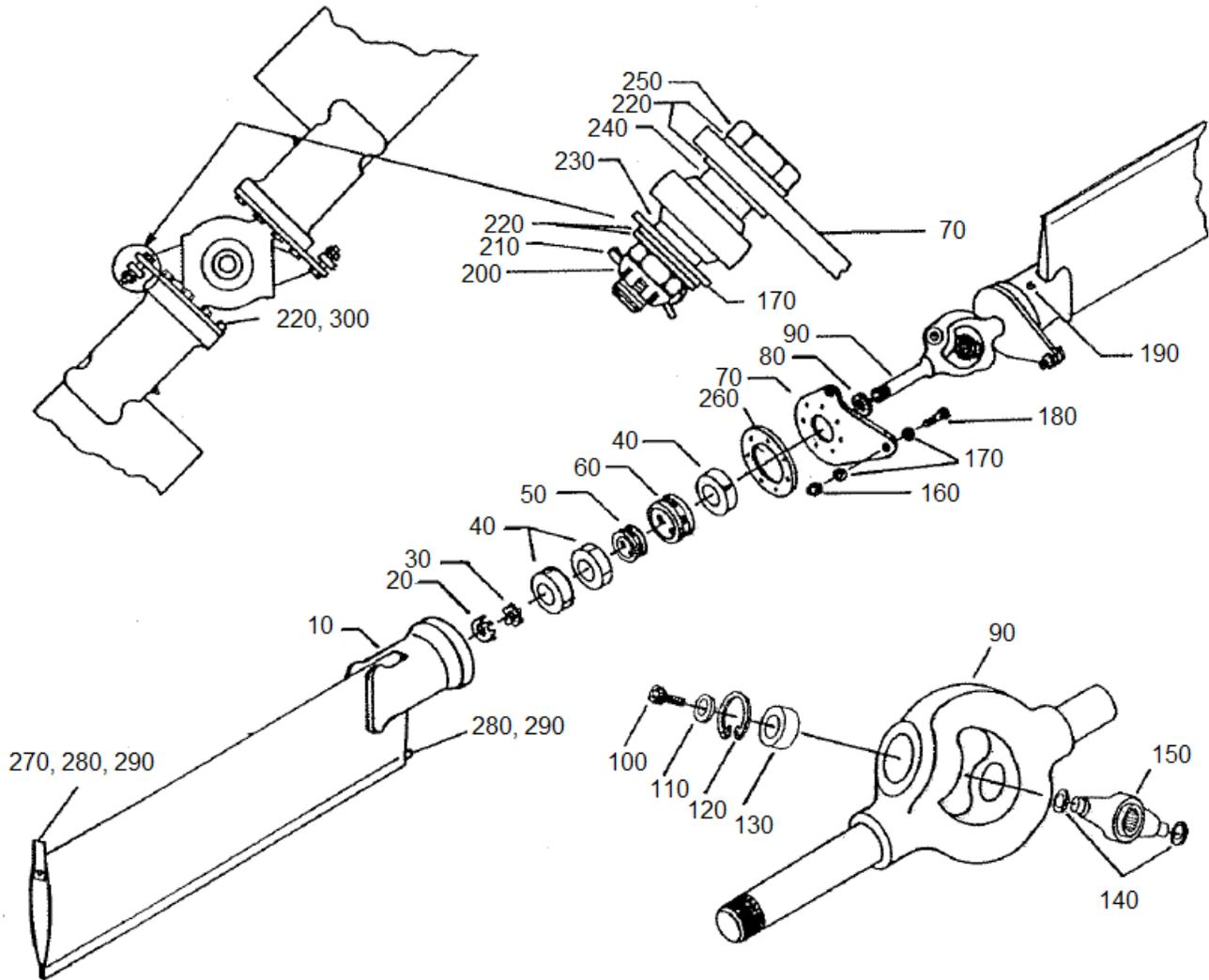

FIGURE 12-10. 28-150000-7, -10 TAIL ROTOR ASSEMBLY

ENSTROM F-28/280 SERIES ILLUSTRATED PARTS CATALOG

FIGURE 12-10. 28-150000-7, -10 TAIL ROTOR ASSEMBLY

ITEM NUMBER	PART NUMBER	DESCRIPTION	QTY PER ASSY	MODELS AFFECTED						
				F-28A	280	F-28C	280C	F-28F	280F	280FX
-	28-150000-7	Tail Rotor Assembly	REF			X	X			
-	28-150000-10	Tail Rotor Assembly	REF			X	X			
10	28-150001-5	. Blade & Grip Assembly	1			X	X			
20	SL61W-5P	. Lock Washer	2			X	X			
30	SL61N-5P	. Lock Nut	2			X	X			
40	ECD035-11	. Bearing Set (3 pc)	2			X	X			
40	304R	. Bearing Set (3 pc) (Alternate)	2			X	X			
40	7304DT	. Bearing Set (3 pc) (Alternate)	2			X	X			
50	28-150016-11	. Spacer	2			X	X			
60	28-150015-11	. Spacer	2			X	X			
70▲	28-150046-1	. Pitch Arm	2			X	X			
-70A*	28-150060-11	. Pitch Arm	2			X	X			
80	28-150026-11	. Spacer	2			X	X			
90	28-150014-14	. Spindle	1			X	X			
100	MS21262-6	. Screw	2			X	X			
110	28-14120-11	. Washer	2			X	X			
120	28-14121-11	. Snap Ring	2			X	X			
130	KRP8A-H	. Bearing	2			X	X			
130	KRP8A-C	. Bearing (Superseded by KRP8A-H)	2			X	X			
140	28-15203-1	. Shim Set	2			X	X			
150	28-15206-1	. Hub	1			X	X			
160	MS21083N4	. Nut	2			X	X			
160	AN364-428A	. Nut (Superseded by MS21083N4)	2			X	X			
170	ECD050-11	. Washer	4			X	X			
170	1/4 Harper	. Washer (Alternate)	4			X	X			
180	NAS6604-1	. Bolt	2			X	X			
180	AN4-4A	. Bolt (Superseded by NAS6604-1)	2			X	X			
190	1650	. Lube Fitting	2			X	X			

ENSTROM F-28/280 SERIES ILLUSTRATED PARTS CATALOG

FIGURE 12-10. 28-150000-7, -10 TAIL ROTOR ASSEMBLY

ITEM NUMBER	PART NUMBER	DESCRIPTION	QTY PER ASSY	MODELS AFFECTED						
				F-28A	280	F-28C	280C	F-28F	280F	280FX
-	28-16380	Tail Rotor Blades, Gearbox & Controls Installation	REF			X	X			
200	MS17825-4	. Nut	2			X	X			
200	F12-NE-4753-048	. Nut	2			X	X			
210	MS24665-151	. Cotter Pin	2			X	X			
210	AN381-2-8	. Cotter Pin (Superseded by MS24665-151)	2			X	X			
220	NAS1149F0463P	. Washer	A/R			X	X			
220	AN960-416	. Washer (Alternate)	A/R			X	X			
230	28-16353-4	. Spacer	2			X	X			
240	28-16353-3	. Spacer	2			X	X			
250	NAS6604D15	. Bolt	2			X	X			
250	AN4-13	. Bolt (Superseded by NAS6604D15)	2			X	X			
260▲	28-150048-1	. Plate	2			X	X			
270	28-17308-1	. Strike Indicator	2			X	X			
280	MS35207-10-16	. Screw	4			X	X			
280	AN515-10-16	. Screw (Superseded by MS35207-10-16)	4			X	X			
290	NAS1149F0363P	. Washer	A/R			X	X			
290	AN960-10	. Washer (Alternate)	A/R			X	X			
300	NAS6604H3	. Bolt	16			X	X			
300	AN4H-5A	. Bolt (Superseded by NAS6604H3)	16			X	X			
-	MR-18	. Bearing	2			X	X			
-*	28-150033-1	. Bumper	2			X	X			
-*	28-150063-11	. Bearing Sleeve	2			X	X			
-*	28-150055	. Bearing Retainer	2			X	X			

▲ Items included in 28-150000-7 only.

* Items included in 28-150000-10 only.

ENSTROM F-28/280 SERIES ILLUSTRATED PARTS CATALOG

I

INTENTIONALLY LEFT BLANK

ENSTROM F-28/280 SERIES ILLUSTRATED PARTS CATALOG

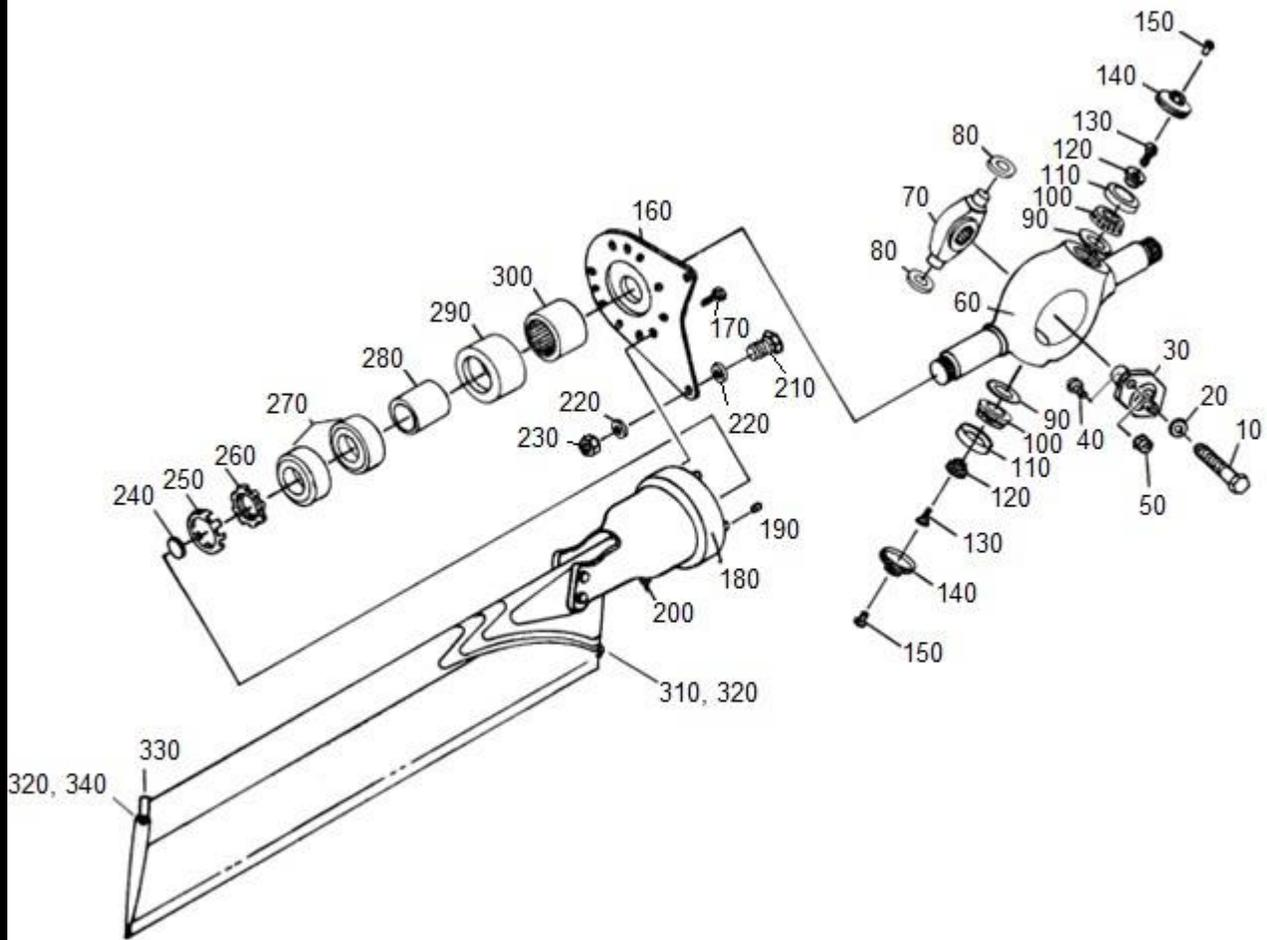

F-28C All S/Ns
280C All S/Ns
F-28F Prior to S/N 803
280F All S/Ns
280FX Prior to S/N 2078

FIGURE 12-11. 28-150050-2 TAIL ROTOR ASSEMBLY

ENSTROM F-28/280 SERIES ILLUSTRATED PARTS CATALOG

FIGURE 12-11. 28-150050-2 TAIL ROTOR ASSEMBLY

ITEM NUMBER	PART NUMBER	DESCRIPTION	QTY PER ASSY	MODELS AFFECTED						
				F-28A	280	F-28C	280C	F-28F	280F	280FX
—*	28-150050-2	Tail Rotor Assembly	REF			X	X	X	X	X
10	NAS6607-5	. Bolt	1			X	X	X	X	X
10	AN7H-7A	. Bolt (Superseded by NAS6607-5)	1			X	X	X	X	X
20	NAS1149F0763P	. Washer	1			X	X	X	X	X
20	AN960-716	. Washer (Alternate)	1			X	X	X	X	X
—	28-15030-1	. Teeter Stop Assembly	1			X	X	X	X	X
30	28-15028-1	. . Mount Plate	1			X	X	X	X	X
40	16-1	. . Bumper	2			X	X	X	X	X
50	MS21083N06	. . Nut	2			X	X	X	X	X
50	AN364-632A	. . Nut (Superseded by MS21083N06)	2			X	X	X	X	X
60	28-150064-11	. Spindle	1			X	X	X	X	X
70	28-150051-1	. Hub	1			X	X	X	X	X
80	MS20002-C6	. Washer (Used with 28-160062-11)	2			X	X	X	X	X
90	28-150062-13	. Shield	2			X	X	X	X	X
90	28-150062-11	. Shield (Replaced by 28-150062-13)	2			X	X	X	X	X
100	A2126	. Bearing Cone	2			X	X	X	X	X
110	A2037	. Bearing Cup	2			X	X	X	X	X
120	28-150053-1	. Spacer	2			X	X	X	X	X
130	NK509-8R6	. Screw	2			X	X	X	X	X
140	28-150066-11	. Retention Cap	2			X	X	X	X	X
150	1885	. Lube Fitting	2			X	X	X	X	X
160	28-150060-11	. Pitch Arm	2			X	X	X	X	X
170	NAS6604H1	. Bolt	16			X	X	X	X	X
170	AN4H-4A	. Bolt (Superseded by NAS6604H1)	16			X	X	X	X	X
—	MS20995C32	. Safety Wire	24"			X	X	X	X	X
180	28-150001-5	. Tail Rotor Blade & Grip Assembly	2			X	X	X	X	X
190	28-150044-5	. . Dowel	6			X	X	X	X	X
200	1650	. Lube Fitting	2			X	X	X	X	X

ENSTROM F-28/280 SERIES ILLUSTRATED PARTS CATALOG

FIGURE 12-11. 28-150050-2 TAIL ROTOR ASSEMBLY

ITEM NUMBER	PART NUMBER	DESCRIPTION	QTY PER ASSY	MODELS AFFECTED						
				F-28A	280	F-28C	280C	F-28F	280F	280FX
210	NAS6604H3	. Bolt	2			X	X	X	X	X
210	AN4H-5A	. Bolt (Superseded by NAS6604H3)	2			X	X	X	X	X
220	ECD050-11	. Washer	4			X	X	X	X	X
220	1/4 Harper	. Washer (Alternate)	4			X	X	X	X	X
230	MS21083N4	. Nut	2			X	X	X	X	X
230	AN364-428A	. Nut (Superseded by MS21083N4)	2			X	X	X	X	X
240	28-15033-5	. Bumper	2			X	X	X	X	X
240	28-15033-11	. Bumper (Replaced by 28-15033-5)	2			X	X	X	X	X
250	SL61W-5P	. Lock Washer	2			X	X	X	X	X
260	SL61N-5P	. Nut	2			X	X	X	X	X
270	ECD002-13	. Bearing Set (2)	2			X	X	X	X	X
270	7304DT	. Bearing Set (2) (Alternate)	2			X	X	X	X	X
280	28-150063-11	. Bearing Sleeve	2			X	X	X	X	X
290	28-150055-1	. Bearing Retainer	2			X	X	X	X	X
300	MR-18	. Bearing	2			X	X	X	X	X
310	AN520-10-16	. Screw	2			X	X	X	X	X
320	NAS1149F0363P	. Washer	A/R			X	X	X	X	X
320	AN960-10	. Washer (Alternate)	A/R			X	X	X	X	X
330	28-17308-1	. Strike Tab	2			X	X	X	X	X
340	AN520-10-40	. Screw	2			X	X	X	X	X

* May upgrade to latest production in accordance with SIL 0141. If aircraft has incorporated SIL 0141, see Figure 12-10.

ENSTROM F-28/280 SERIES ILLUSTRATED PARTS CATALOG

|

INTENTIONALLY LEFT BLANK

ENSTROM F-28/280 SERIES ILLUSTRATED PARTS CATALOG

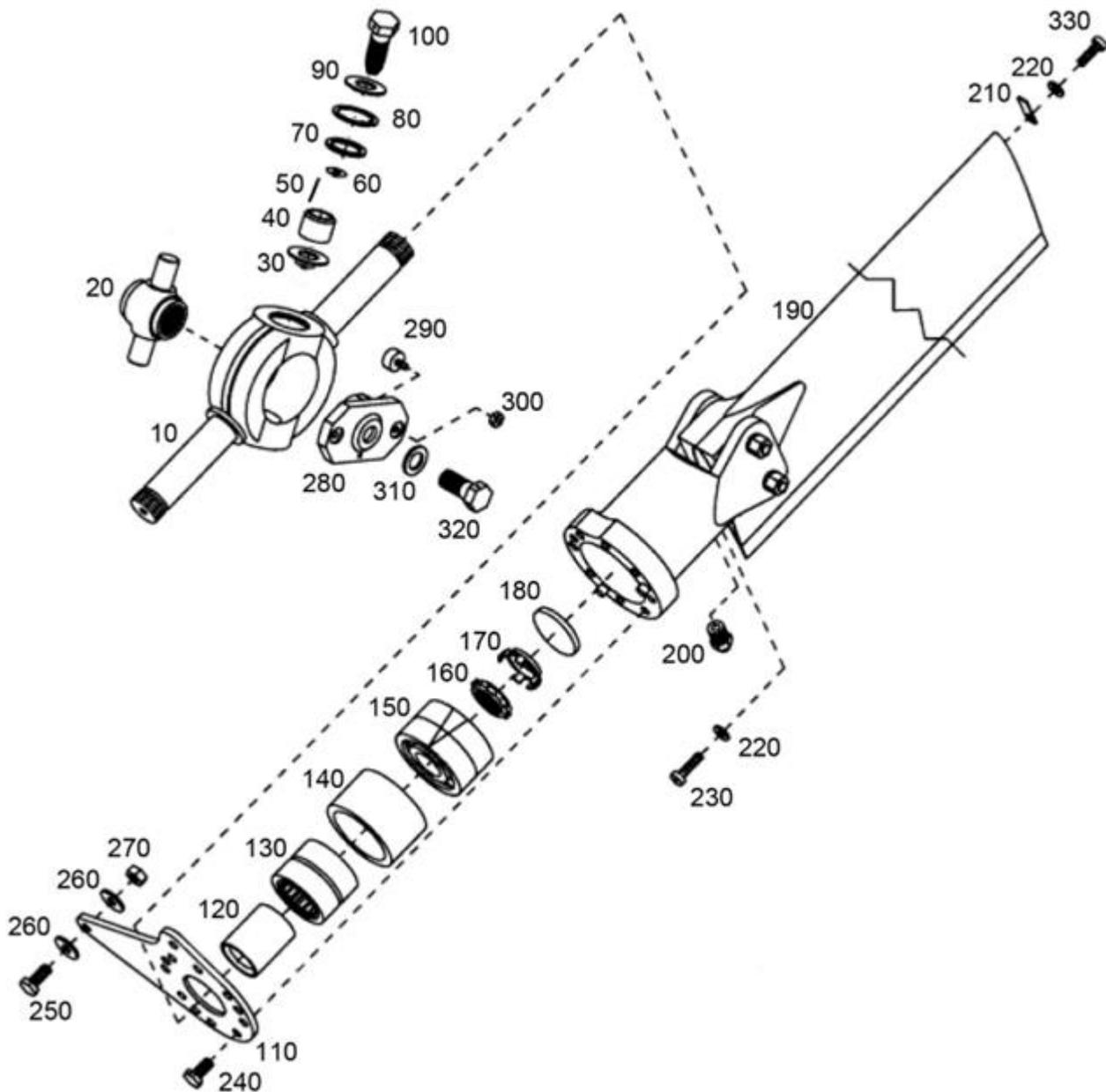

FIGURE 12-12. 28-150073-1, -5 TAIL ROTOR ASSEMBLY

ENSTROM F-28/280 SERIES ILLUSTRATED PARTS CATALOG

FIGURE 12-12. 28-150073-1, -5 TAIL ROTOR ASSEMBLY

ITEM NUMBER	PART NUMBER	DESCRIPTION	QTY PER ASSY	MODELS AFFECTED						
				F-28A	280	F-28C	280C	F-28F	280F	280FX
-*	28-150073-1	Tail Rotor Assembly	REF			X	X	X	X	X
-*	28-150073-5	Tail Rotor Assembly	REF			X	X	X	X	X
10	28-150074-13	. Spindle	1			X	X	X	X	X
10	28-150074-11	. Spindle (Alternate)	1			X	X	X	X	X
20	28-150067-11	. Hub	1			X	X	X	X	X
-20A●	28-150067-13	. Hub	1			X	X	X	X	X
30	959-3	. Wiper	2			X	X	X	X	X
-30A●	28-150075-11	. Shield	2			X	X	X	X	X
40	28-150070-11	. Spherical Bearing	2			X	X	X	X	X
-40A●	28-150070-13	. Spherical Bearing	2			X	X	X	X	X
50	MS16555-618	. Pin	2			X	X	X	X	X
60	28-150072-1	. Shim, .001"	A/R			X	X	X	X	X
60	28-150072-2	. Shim, .002"	A/R			X	X	X	X	X
60	28-150072-3	. Shim, .003"	A/R			X	X	X	X	X
60	28-150072-5	. Shim, .005"	A/R			X	X	X	X	X
60	28-150072-7	. Shim, .0075"	A/R			X	X	X	X	X
60	28-150072-10	. Shim, .010"	A/R			X	X	X	X	X
60	28-150072-20	. Shim, .020"	A/R			X	X	X	X	X
70	28-150072-21	. Retainer Plate	2			X	X	X	X	X
80	N5002-100	. Snap Ring	2			X	X	X	X	X
90	28-150072-11	. Washer	2			X	X	X	X	X
100▲	NP138BS1032-N-8Z	. Bolt	2			X	X	X	X	X
110	28-150060-11	. Pitch Arm	2			X	X	X	X	X
120	28-150063-11	. Bearing Sleeve	2			X	X	X	X	X
130	ECD001-11	. Bearing	2			X	X	X	X	X
140	28-150055-1	. Bearing Retainer	2			X	X	X	X	X
150	ECD002-11	. Bearing Assembly (Set)	2			X	X	X	X	X
160	SL61N-5P	. Nut	2			X	X	X	X	X
170	SL61W-5P	. Lock Washer	2			X	X	X	X	X

ENSTROM F-28/280 SERIES ILLUSTRATED PARTS CATALOG

FIGURE 12-12. 28-150073-1, -5 TAIL ROTOR ASSEMBLY

ITEM NUMBER	PART NUMBER	DESCRIPTION	QTY PER ASSY	MODELS AFFECTED						
				F-28A	280	F-28C	280C	F-28F	280F	280FX
180	28-15033-5	. Bumper	2			X	X	X	X	X
190	28-150001-5	. Tail Rotor Blade and Grip Assembly	2			X	X	X	X	X
200	1650	. Lube Fitting	2			X	X	X	X	X
210	28-17308-1	. Strike Tab	2			X	X	X	X	X
220	NAS1149F0363P	. Washer	A/R			X	X	X	X	X
220	AN960-10	. Washer (Alternate)	A/R			X	X	X	X	X
230	AN520-10-16	. Screw	2			X	X	X	X	X
240	NAS6604H1	. Bolt	16			X	X	X	X	X
240	AN4H-4A	. Bolt (Superseded by NAS6604H1)	16			X	X	X	X	X
-	MS20995C32	. Lockwire	A/R			X	X	X	X	X
250	NAS6604-3	. Bolt	2			X	X	X	X	X
250	AN4-5A	. Bolt (Superseded by NAS6604-3)	2			X	X	X	X	X
260	ECD050-11	. Washer	4			X	X	X	X	X
260	1/4 Harper	. Washer (Alternate)	4			X	X	X	X	X
270	MS21083N4	. Nut	2			X	X	X	X	X
270	AN364-428A	. Nut (Superseded by MS21083N4)	2			X	X	X	X	X
-	28-15030-1	. Teeter Stop Assembly	1			X	X	X	X	X
280	28-15028-1	. . Mount Plate	1			X	X	X	X	X
290	16-1	. . Bumper	2			X	X	X	X	X
300	MS21083N06	. . Nut	2			X	X	X	X	X
300	AN364-632A	. . Nut (Superseded by MS21083N06)	2			X	X	X	X	X
310	NAS1149F0763P	. Washer	1			X	X	X	X	X
310	AN960-716	. Washer (Alternate)	1			X	X	X	X	X
320	NAS6607-5	. Bolt	1			X	X	X	X	X
320	AN7H-7A	. Bolt (Superseded by NAS6607-5)	1			X	X	X	X	X
330	AN520-10-40	. Screw	2			X	X	X	X	X

ENSTROM F-28/280 SERIES ILLUSTRATED PARTS CATALOG

- Parts used with 28-150073-5 only.
- ▲ NAS6603-2 and Loctite is an acceptable alternate.
- * May upgrade to latest production in accordance with SIL 0141. If aircraft has incorporated SIL 0141, see Figure 12-10.

ENSTROM F-28/280 SERIES ILLUSTRATED PARTS CATALOG

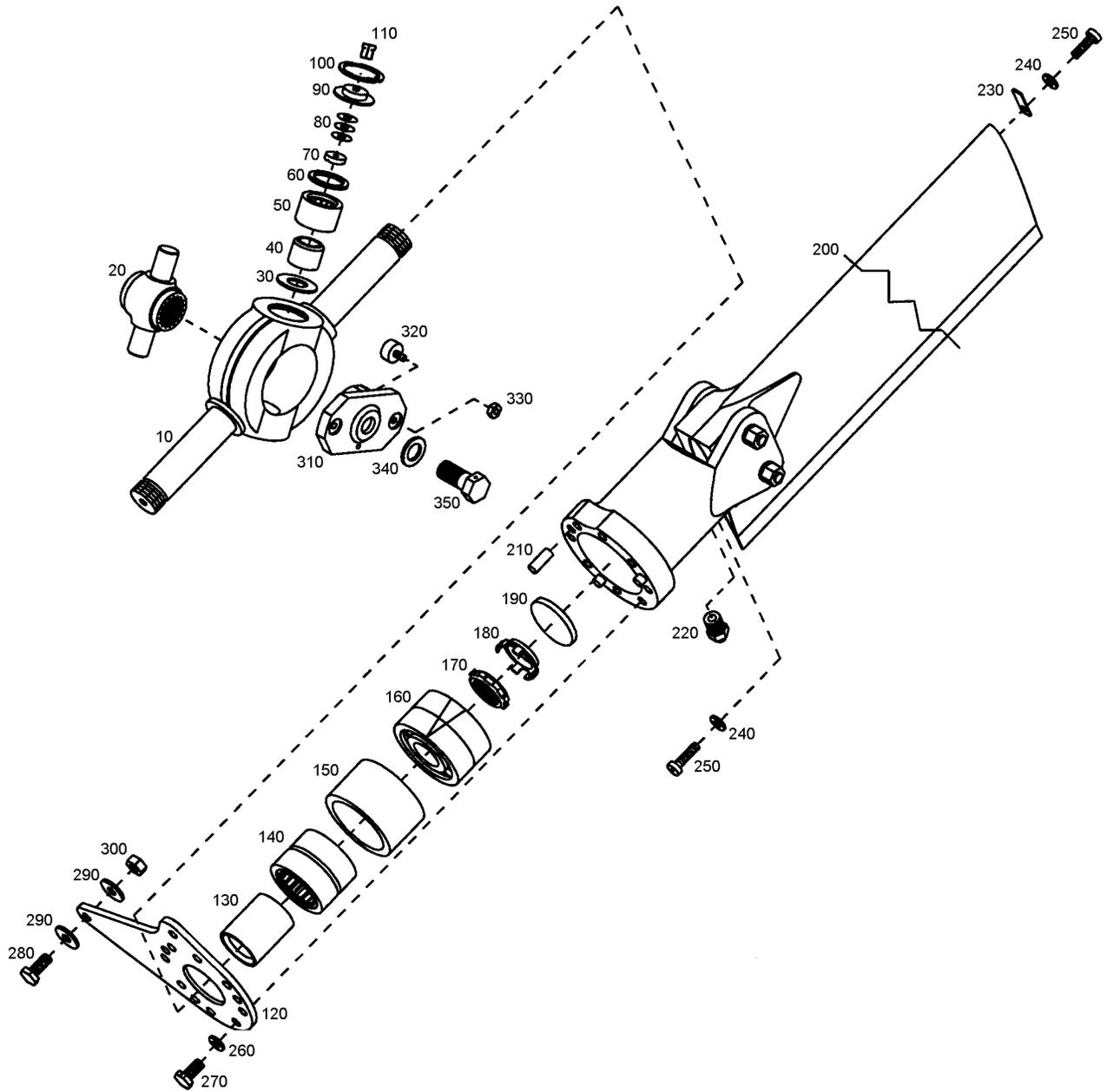

FIGURE 12-13. 28-150079-1, -5 TAIL ROTOR ASSEMBLY

ENSTROM F-28/280 SERIES ILLUSTRATED PARTS CATALOG

FIGURE 12-13. 28-150079-1, -5 TAIL ROTOR ASSEMBLY

ITEM NUMBER	PART NUMBER	DESCRIPTION	QTY PER ASSY	MODELS AFFECTED						
				F-28A	280	F-28C	280C	F-28F	280F	280FX
-Δ	28-150079-1	Tail Rotor Assembly	REF			X	X	X	X	X
-	28-150079-5	Tail Rotor Assembly	REF			X	X	X	X	X
-	28-150077-1	. Spindle Assembly	1			X	X	X	X	X
-	28-150077-11	. Spindle Assembly (Alternate)	1			X	X	X	X	X
10◆	28-150074-13	. Spindle	1			X	X	X	X	X
20◆	28-150067-15	. Hub	1			X	X	X	X	X
30◆	28-150076-17	. Washer	2			X	X	X	X	X
40◆	28-150076-15	. Journal	2			X	X	X	X	X
50◆	B-1210	. Bearing	2			X	X	X	X	X
60◆	28-150076-19	. Seal	2			X	X	X	X	X
70◆	28-150076-13	. Thrust Bumper	2			X	X	X	X	X
80◆	28-150078-10	. Shim, .010"	A/R			X	X	X	X	X
80◆	28-150078-12	. Shim, .002"	A/R			X	X	X	X	X
80◆	28-150078-13	. Shim, .003"	A/R			X	X	X	X	X
80◆	28-150078-15	. Shim, .005"	A/R			X	X	X	X	X
90◆	28-150076-1	. End Plate	2			X	X	X	X	X
90◆	28-150076-21	. End Plate (Replaced by 28-150076-1)	2			X	X	X	X	X
100◆	N5002-100	. Retaining Ring	2			X	X	X	X	X
110	1877	. Grease Fitting	2			X	X	X	X	X
120◆	28-150060-11	. Pitch Arm	2			X	X	X	X	X
130◆	28-150063-11	. Sleeve	2			X	X	X	X	X
-130A◆▼	28-150063-13	. Sleeve	2			X	X	X	X	X
140◆	ECD001-11	. Bearing	2			X	X	X	X	X
150◆	28-150055-13	. Bearing Retainer	2			X	X	X	X	X
150◆	28-150055-1	. Bearing Retainer (Replaced by 28-150055-13)	2			X	X	X	X	X
-150A◆▼	28-150055-15	. Bearing Retainer	2			X	X	X	X	X
160◆	ECD002-13	. Bearing	2			X	X	X	X	X
160◆	ECD002-11	. Bearing (Replaced by ECD002-13)	2			X	X	X	X	X

ENSTROM F-28/280 SERIES ILLUSTRATED PARTS CATALOG

FIGURE 12-13. 28-150079-1, -5 TAIL ROTOR ASSEMBLY

ITEM NUMBER	PART NUMBER	DESCRIPTION	QTY PER ASSY	MODELS AFFECTED						
				F-28A	280	F-28C	280C	F-28F	280F	280FX
170♦	SL61N-5F	. Nut	2			X	X	X	X	X
170♦	SL61N-5P	. Nut (Alternate)	2			X	X	X	X	X
180♦	SL61W-5P	. Lock Washer	2			X	X	X	X	X
190	28-15033-5	. Bumper	2			X	X	X	X	X
200	28-150001-5	. Tail Rotor Blade and Grip Assembly	2			X	X	X	X	X
210	28-150044-5	. . Dowel	3			X	X	X	X	X
220	1650	. Lube Fitting	2			X	X	X	X	X
230	28-17308-1	. Strike Indicator	2			X	X	X	X	X
240	NAS1149F0316P	. Washer	A/R			X	X	X	X	X
240	AN960-10	. Washer (Superseded by NAS1149F0316P)	A/R			X	X	X	X	X
-	NAS1149F0332P	. Washer	A/R			X	X	X	X	X
-	AN960-10L	. Washer (Superseded by NAS1149F0332P)	A/R			X	X	X	X	X
250*	MS35207-262	. Screw	4			X	X	X	X	X
250*	MS35207-AR	. Screw (Replaced by MS35207-262)	4			X	X	X	X	X
260	NAS1149F0432P	. Washer	16			X	X	X	X	X
260	AN960-416L	. Washer (Alternate)	16			X	X	X	X	X
270	NAS6604H1	. Bolt	16			X	X	X	X	X
270	AN4H4A	. Bolt (Superseded by NAS6604H1)	16			X	X	X	X	X
-	MS20995C32	. Safety Wire	A/R			X	X	X	X	X
280	NAS6604-3	. Bolt	2			X	X	X	X	X
280	AN4-5A	. Bolt (Superseded by NAS6604-3)	2			X	X	X	X	X
290	ECD050-17	. Washer	4			X	X	X	X	X
290	ECD050-11	. Washer (Alternate)	4			X	X	X	X	X
290	1/4 Harper	. Flat Washer, 1/4 X 11/16 (Alternate)	4			X	X	X	X	X
300	MS21083N4	. Nut	2			X	X	X	X	X

ENSTROM F-28/280 SERIES ILLUSTRATED PARTS CATALOG

FIGURE 12-13. 28-150079-1, -5 TAIL ROTOR ASSEMBLY

ITEM NUMBER	PART NUMBER	DESCRIPTION	QTY PER ASSY	MODELS AFFECTED						
				F-28A	280	F-28C	280C	F-28F	280F	280FX
300	AN364-428A	. Nut (Superseded by MS21083N4)	2			X	X	X	X	X
-	28-15030-1	Teeter Stop Assembly	REF			X	X	X	X	X
310	28-15028-1	. Mount Plate	1			X	X	X	X	X
320	16-1	. Bumper	2			X	X	X	X	X
330	MS21083N06	. Nut	2			X	X	X	X	X
330	AN364-632A	. Nut (Superseded by MS21083N06)	2			X	X	X	X	X
340	NAS1149F0763P	. Washer	1			X	X	X	X	X
340	AN960-716	. Washer (Alternate)	1			X	X	X	X	X
350	NAS6607-5	. Bolt	1			X	X	X	X	X
350	AN7H7A	. Bolt (Superseded by NAS6607-5)	1			X	X	X	X	X
-**	28-150079-901	. Tail Rotor Spindle Assembly	1			X	X	X	X	X

△ Effectivity F-28F S/N 818 and subsequent, 280FX S/N 2111 and subsequent; Eligibility F-28F S/N 509 and subsequent, 280FX S/N /2001 and subsequent; and helicopters modified by SIL 0141.

▼ Parts used with 28-150079-5 only.

* Length as required.

** Replaces Kit 28-010se56-1.

◆ Items included in Kit 28-150079-901.