



SERVICE INFORMATION LETTER

SERVICE INFORMATION LETTER NO. T-027

Revision 4

Page 1 of 6

Revision 4 replaces AN960-416 washers (cad plated carbon steel) with NAS1149C0463R washers (passivated stainless steel). (Revision 4 supersedes SIL T-027 Revision 3.)

DATE: November 10, 2017

1. SUBJECT: Tail Rotor P/C Link Installation Inspection

2. MODEL: 480 and 480B

3. EFFECTIVITY: All

4. BACKGROUND:

Enstrom has determined a corrective action for premature wear on the tail rotor pitch change link rod end bearings. The premature wear is caused by excessive rotational movement of the pitch link. In addition, Enstrom has received a report of damage to the pitch arm at the pitch change link attachment. In this instance, the bolt hole wore to the extent that tail rotor performance was compromised. The damage has been attributed to missing hardware for attaching the pitch change link to the pitch arm, which led to loss of torque.

The original release of this Service Information Letter (SIL) revised the method of attachment to reduce the rotational movement of the pitch change links and provided information on incorporating the modification as an owner/operator option. Revision 1 supersedes the original release and recommends the inspection of the tail rotor pitch change link installation for proper hardware, modification of the installation hardware, if necessary, and inspection of the required torque during the next scheduled inspection. Compliance with Revision 1 is recommended regardless of the response to the original SIL.

Revision 2 incorporates content originally documented in SIL T-020 and introduces a pitch change link assembly upgrade. Enstrom initially released a fixed length tail rotor pitch change link assembly (P/N 28-16391-1) for service that significantly reduces the costs and man-hours related to tail rotor pitch change link maintenance. This P/N has been upgraded to P/N 28-16391-5. The P/N 28-16391-5 is manufactured with one rod end canted 5°. (NOTE: P/N 28-16391-3, a preceding intermediate upgrade with the canted 5° rod end, is inactive.)

November 10, 2017

As a result of recent evaluations concerning loosening hardware, Revision 3 incorporates additional inspection criteria pertaining to hardware condition.

Revision 4 incorporates information on required washer replacement.

The inspections set forth in this SIL are currently stated in the applicable maintenance manual and are reiterated to emphasize the importance of performing periodic inspections as recommended in the maintenance manual.

Technical aspects of this SIL are FAA Approved.

5. COMPLIANCE:

In order to preclude damage to components in the tail rotor rotating controls, Enstrom recommends inspecting the tail rotor rotating controls for proper hardware, modifying the installation hardware, if necessary, and checking the torque of the pitch change link attachment hardware in accordance with the procedure provided in paragraph 5.1.

CAUTION

Do not mix the installation of P/N 28-16391-3 or P/N 28-16391-5 pitch change link assemblies with either P/N 28-16391-1 or P/N 28-16398-901. Install a set (2 each) of the pitch link assemblies, P/N 28-16391-5, during the initial installation.

NOTE

The installation may have a combination of P/N 28-16391-3 and P/N 28-16391-5 pitch change link assemblies.

For owners/operators who implemented the original issue of SIL T-020 and want to upgrade to the new tail rotor pitch change link, P/N 28-16391-5 is a direct replacement for the pitch link assembly P/N 28-16391-1.

For owners/operators who did not implement the original issue of SIL T-020 and want to upgrade to the new tail rotor pitch link, P/N 28-16391-5 is also a direct replacement for the pitch link assembly, P/N 28-16398-901.

For owners/operators who implemented the upgrade to P/N 28-16391-3 tail rotor pitch change link assembly, P/N 28-16391-5 is a direct replacement for P/N 28-16391-3.

5.1. INSPECTION PROCEDURE:

5.1.1 Inspect both tail rotor pitch link change installations for proper and secure installation hardware in accordance with Figure 1.

5.1.2 If a pitch change link installation does not have proper and secure installation hardware, proceed to step 5.1.4.

November 10, 2017

- 5.1.3 If a pitch change link installation has proper and secure installation hardware, verify torque (55-75 in-lbs/6.2-8.5 Nm). If torque is adequate, no additional inspection is required. If the torque is inadequate, proceed to step 5.1.4.
- 5.1.4 Disconnect the applicable pitch change link (10) from the tail rotor pitch arm. Keep the bolt and washer stack up together.
- 5.1.4.1 Inspect the bolt, spacers, O-ring, and washers for wear. Pay particular attention to the washer surfaces for any distinct wear pattern through the cad-plate and extending into the base material.
- 5.1.5 Inspect the pitch change link for cracks, corrosion, bends, and damage. Corrosion, nicks, or scratches in the barrel or rod end outer race not exceeding 0.010"/0.25 mm deep may be burnished out. Replace the rod end or barrel if cracked or if damage exceeds 0.010"/0.25 mm deep.
- 5.1.6 Inspect the rod ends for excessive play. Replace the rod end if its axial play exceeds 0.005"/0.13 mm.
- 5.1.7 Inspect the pitch arm for damage. Replace the pitch arm if cracks are detected or the pitch link bolt hole exceeds 0.251"/6.38 mm diameter. Edge nicks may not exceed 0.005"/0.13 mm deep. Polish and blend locally to a maximum 0.008"/0.20 mm deep.
- 5.1.8 Connect the pitch change link (10) to the pitch arm with the hardware in the following sequence: bolt (1) (bolt head installed in the direction of rotation), Harper washer (2), thin spacer (3), O-ring (4), pitch change link rod end (10), thick spacer (5), washer (6), pitch arm, washer(s) (7), and nut (9). Torque the nuts (55-75 in-lbs/6.2-8.5 Nm) and install new cotter pin (8).

NOTE

The pre-existing spacer may have been wider or narrower than the replacement spacer. Adjust the number of washers under the nut to account for the dimensional difference.

NOTE

Any modification must be made to both sides to maintain the dynamic balance of the tail rotor.

- 5.1.9 Repeat the inspection for the second pitch link assembly.
- 5.1.10 If any changes are made to the tail rotor rotating controls assembly hardware as a result of incorporating missing hardware, dynamically balance the tail rotor assembly.

November 10, 2017

5.2. REPLACEMENT PROCEDURE:

5.2.1 Remove and install the tail rotor pitch change link assemblies in accordance with the applicable maintenance instructions for each model aircraft and in accordance with step 5.1.8 above. **NOTE:** The P/N 28-16391-5 (and P/N 28-16391-3) tail rotor pitch link assembly has the label “T/R↑BLADE” etched on the rod end that is canted 5°. This end must attach to the tail rotor and the arrow must point toward the tail rotor blade (see photo in Figure 1).

5.2.2 Return tail rotor pitch link assemblies, P/N 28-16391-3 or P/N 28-16391-5, with worn bearings to Enstrom for exchange.

5.3. PARTS: See Figure 1.

Enstrom has established an exchange program for pitch link assemblies, P/N 28-16391-3 or P/N 28-16391-5, with worn bearings. Contact Customer Service for more information.

6. SPECIAL TOOLS: None

7. MAN-HOURS: Inspection: 5 minutes

8. WARRANTY: Per Enstrom Helicopter Warranty policy.

9. WEIGHT CHANGE: None

10. LOG BOOK ENTRY: As required for maintenance actions.

11. REPETITIVE ACTION:

Inspect the tail rotor assembly at every 100 hour/annual inspection as recommended in Section 4 of the maintenance manual. During the scheduled inspections, perform the detailed tail rotor assembly inspections listed in paragraphs 9-47 and 12-123 of the maintenance manual.

Per the requirements of SDB T-055, contact Enstrom Customer Service to report any finding of loose hardware. Also, provide available information regarding the condition of the hardware, if removed and inspected in accordance with this SIL.

November 10, 2017

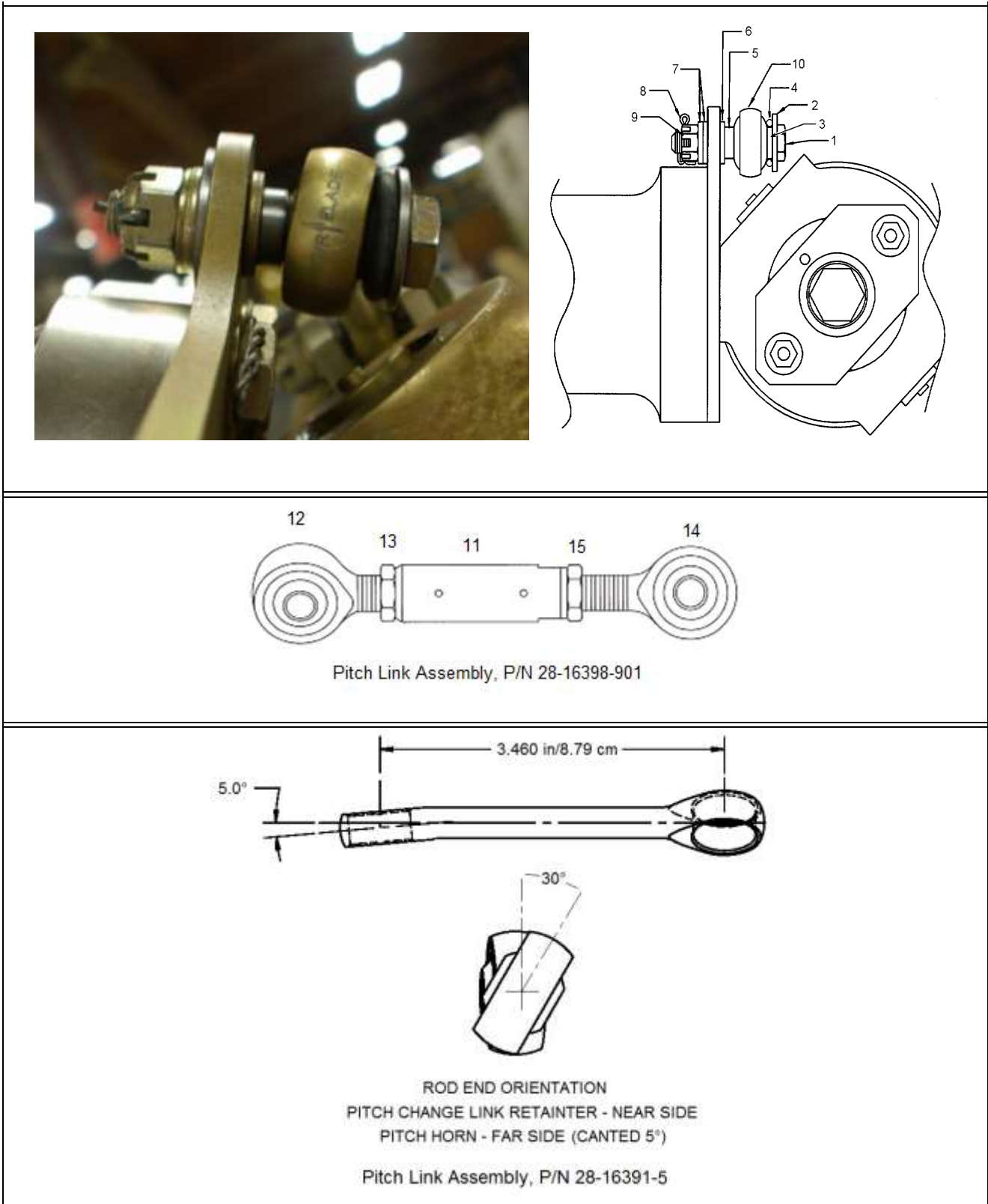

Figure 1. Tail Rotor Rotating Controls

November 10, 2017

Figure 1. Tail Rotor Rotating Controls

ITEM NUMBER	PART NUMBER	DESCRIPTION	QTY PER ASSY
1	AN4-13	. Bolt	2
2	ECD050-11	. Washer, Flat	2
3	28-16353-5	. Spacer (0.072 +0.002/-0.000)	2
4	MS28775-111	. O-Ring	2
5	28-16353-3	. Spacer (0.125 +0.010/-0.000)	2
6	NAS1149C0463R	. Washer	2
7*	NAS1149C0463R	. Washer	A/R
7*	NAS1149C0432R	. Washer	A/R
7*	ECD050-11	. Washer, Flat	A/R
8	MS24665-1013	. Cotter Pin	2
9	MS17825-4	. Nut	2
10	28-16391-1	. Pitch Change Link Assembly (Alternate)	2
10**	28-16391-3	. Pitch Change Link Assembly (Inactive)	2
10**	28-16391-5	. Pitch Change Link Assembly (Preferred)	2
10	28-16398-901	. Pitch Change Link Assembly (Alternate)	2
11	28-16345-1	. . Barrel	1
12	11-691-04	. . Rod End	1
13	AN316-5L	. . Nut	1
14	01-691-04	. . Rod End	1
15	AN316-5R	. . Nut	1

* Use as required for dynamically balancing the tail rotor. Each AN960 washer is to be replaced with its equivalent size NAS1149C04XXR washer.

** Install each pitch change link assembly with the rod end labeled T/R↑BLADE on the tail rotor pitch horn side with arrow pointing toward the tail rotor blade.