

**ENSTROM F-28F/280FX OPERATOR'S
MANUAL**

AND

FAA APPROVED

ROTORCRAFT FLIGHT MANUAL

SUPPLEMENT

GARMIN GMA 350Hc

* * * * *

REPORT NO. 28-AC-080

HELICOPTER SERIAL NO. _____

HELICOPTER REGISTRATION NO. _____

* * * * *

**THIS SUPPLEMENT MUST BE CARRIED IN THE
HELICOPTER AT ALL TIMES IF EQUIPPED WITH THE
GMA 350HC INSTALLATION. CHAPTERS 1, 2, 3, AND 4
ARE FAA APPROVED.**

FAA APPROVED 
for: ACTING MANAGER, SOUTHWEST FLIGHT TEST SECTION,
AIR-713
FEDERAL AVIATION ADMINISTRATION
FT. WORTH, TX
DATE 03/28/2019

PROPRIETARY

The information contained herein is proprietary to The Enstrom Helicopter Corporation and shall not be reproduced or disclosed in whole or in part for any PURPOSE except when such user possesses direct, written authorization from Enstrom Helicopter Corporation

INTENTIONALLY LEFT BLANK

FAA Approved: Mar 28/19

Report No. 28-AC-080

Jan 15/19

This electronic document is not linked to a subscription for revision control or distribution. Refer to the Optional Equipment Supplement Publications Status link under the Technical Support Page of the Enstrom Helicopter website for the current revision level of the Rotorcraft Flight Manual Supplement.

LOG OF REVISIONS

Rev. No.	Date	FAA Approved
-	Mar 28/19	D. Barbini
1	May 21/19	R. Nelson

**Approved by the Manager,
Southwest Flight Test Section, AIR-713
Federal Aviation Administration
Ft. Worth, TX**

FAA Approved: May 21/19
Report No. 28-AC-080

Rev. 1
May 15/19

EASA LOG OF REVISIONS

Rev. No.	Date	EASA Approved	FAA Approval on Behalf of EASA
-	NOT EASA APPROVED		
1	Jul 11/19	FAA/EASA T.I.P.*	M. Javed

* Section 3.5.12 T.I.P. Revision 6

ROTORCRAFT FLIGHT MANUAL SUPPLEMENT

GARMIN GMA 350Hc

TABLE OF CONTENTS

<u>CHAPTER</u>	<u>DESCRIPTION</u>	<u>PAGE</u>
	Supplement Cover Page	
	Log of Revisions	i
	Table of Contents.....	iii
	List of Figures.....	iv
	List of Tables	iv
	List of Effective Pages	v
	INTRODUCTION	INTRO-1
CHAPTER 1	OPERATING LIMITATIONS	
1-1	General	1-1
1-2	Placards	1-1
CHAPTER 2	NORMAL PROCEDURES	
2-1	General	2-1
CHAPTER 3	EMERGENCY PROCEDURES	
3-1	General	3-1
CHAPTER 4	PERFORMANCE DATA	
4-1	General	4-1
CHAPTER 5	RESERVED	
CHAPTER 6	WEIGHT/BALANCE AND LOADING	
6-1	General	6-1
CHAPTER 7	SYSTEM DESCRIPTION AND OPERATION	
7-1	System Description.....	7-1
7-2	General Operation	7-3
7-3	Power-Up.....	7-3
7-4	Controls	7-4
7-5	Transceivers	7-4
7-6	Receivers	7-5
7-7	Marker Beacon Receiver	7-5
7-8	Intercom System.....	7-5

ROTORCRAFT FLIGHT MANUAL SUPPLEMENT**GARMIN GMA 350Hc**

CHAPTER 7	SYSTEM DESCRIPTION AND OPERATION	
7-9	Volume Adjustment.....	7-5
7-10	Entertainment Inputs.....	7-6
7-11	Bluetooth	7-7
7-12	Recorder.....	7-7
7-13	Voice Recognition	7-7
7-14	3D Audio	7-7

LIST OF FIGURES

<u>FIGURE</u>	<u>DESCRIPTION</u>	<u>PAGE</u>
7-1	GMA 350Hc Installation	7-2
7-2	GMA 350Hc System Block Diagram.....	7-3
7-3	GMA 350Hc Controls.....	7-4

LIST OF TABLES

<u>TABLE</u>	<u>DESCRIPTION</u>	<u>PAGE</u>
Intro-1	List of Abbreviations.....	INTRO-1
7-1	GMA 350Hc Controls.....	7-8

LIST OF EFFECTIVE PAGES

<u>PAGE</u>	<u>DATE</u>
i	May 15/19
ii	May 15/19
iii	May 15/19
iv	Jan 15/19
v	May 15/19
vi	Jan 15/19
INTRO-1	Jan 15/19
INTRO-2	Jan 15/19
1-1	May 15/19
1-2	Jan 15/19
2-1	Jan 15/19
2-2	Jan 15/19
3-1	Jan 15/19
3-2	Jan 15/19
4-1	Jan 15/19
4-2	Jan 15/19
6-1	Jan 15/19
6-2	Jan 15/19
7-1	May 15/19
7-2	May 15/19
7-3	May 15/19
7-4	Jan 15/19
7-5	Jan 15/19
7-6	Jan 15/19
7-7	May 15/19
7-8	Jan 15/19
7-9	Jan 15/19
7-10	Jan 15/19

INTENTIONALLY LEFT BLANK

INTRODUCTION

Intro-1. General

This supplement contains the operating instructions, procedures, and limitations for the Garmin GMA 350Hc Audio Panel Installation.

The supplement is divided into two basic parts, the FAA approved RFM Supplement and Supplemental Data provided by the Enstrom Helicopter Corporation (Enstrom). Chapters 1, 2, 3, and 4 make up the FAA approved RFM Supplement. It is required by Federal Regulations that this supplement be carried in the helicopter at all times if the GMA 350Hc is installed.

For additional information regarding the supplement format and text emphasis or definitions, refer to the Basic Flight Manual.

Abbreviations noted in this supplement are listed in Table Intro-1.

Table Intro-1. List of Abbreviations

AUX	Auxiliary
CRSR	Cursor
COM	Communication
FAA	Federal Aviation Administration
ICS	Intercom System
MAN	Manual
MKR	Marker
MIC	Microphone
MUS	Music
NAV	Navigation
PA	Public Announcement
PASS	Passenger
PTT	Press to Talk

Table Intro-1. List of Abbreviations

RFM	Rotorcraft Flight Manual
SPKR	Speaker
SQ	Squelch
VOL	Volume

CHAPTER 1. OPERATING LIMITATIONS

1-1. General

1. Refer to the basic RFM.
2. The GMA 350H/350Hc Pilot's Guide, Document Number 190-01134-14, Revision L or later revision, should be referred to for operating instructions and must be kept accessible to the flight crew at all times.

1-2. Placards

1. If marker beacon is not configured, a placard in close proximity to the GMA 350Hc or within view of the pilot on the instrument panel must state:

MARKER BEACON NOT ENABLED

NOTE

Voice Recognition is not authorized for helicopters registered in countries that recognize approvals granted by EASA.

NOTE

The following placard applies only to helicopters registered in countries that recognize approvals granted by EASA.

2. A placard in close proximity to the GMA 350Hc or within view of the pilot on the instrument panel must state:

VOICE COMMANDS DISABLED

INTENTIONALLY LEFT BLANK

CHAPTER 2. NORMAL PROCEDURES

2-1. General

Refer to the basic RFM.

INTENTIONALLY LEFT BLANK

CHAPTER 3. EMERGENCY PROCEDURES

3-1. General

If there is a failure of the GMA 350Hc or when power is not applied, a fail-safe circuit connects the pilot's headset and microphone directly to the COM1 transceiver.

INTENTIONALLY LEFT BLANK

CHAPTER 4. PERFORMANCE DATA

4-1. General

Refer to the basic RFM.

INTENTIONALLY LEFT BLANK

CHAPTER 6. WEIGHT/BALANCE AND LOADING

6-1. General

This installation is included in the basic aircraft weight. Refer to the basic RFM.

INTENTIONALLY LEFT BLANK

CHAPTER 7. SYSTEM DESCRIPTION AND OPERATION

7-1. System Description

NOTE

Voice Recognition is not authorized for helicopters registered in countries that recognize approvals granted by EASA.

1. The GMA 350Hc audio panel provides audio selector functions of microphone and receiver audio selection. The audio panel includes ICS, night vision compatible green annunciation and backlighting, a front panel entertainment/telephone jack, and marker beacon receiver (if configured). Special features of the GMA 350Hc include Voice Recognition, 3D audio capability, and Bluetooth®.
2. The components of the GMA 350Hc installation include the GMA 350Hc audio panel unit located in the radio panel, and entertainment jack (**GMA PLAY**) and the marker beacon sensitivity (**MKR SENS**) toggle switch located on the left side of the radio panel (Figure 7-1) and marker beacon antenna (if configured). The GMA 350Hc installation does not include an external speaker/PA system.
3. The system block diagram is shown in Figure 7-2.
4. Power to the GMA 350Hc system is provided via the avionics master (**AVI MASTER**). Power to the GMA 350Hc audio panel is provided via the **AUDIO PANEL** circuit breaker (5 amp) located on the left side of the lower panel (Figure 7-1).
5. The marker beacon receiver (if configured) detects three marker beacon signals (outer, middle, and inner). The corresponding marker beacon tone is heard. The signal sensitivity can be set with the **MKR SENS** toggle switch (Figure 1). The GMA 350Hc does not have a discrete marker beacon display. Depending on the aircraft configuration, it may be displayed on other avionic equipment.

6. Refer to the GMA 350H/350Hc Pilot's Guide for additional information on the features of the GMA 350Hc (para. 1-2).
7. For night operation, brightness can be adjusted with the **PNL LTS DIMMER** (Figure 7-1).

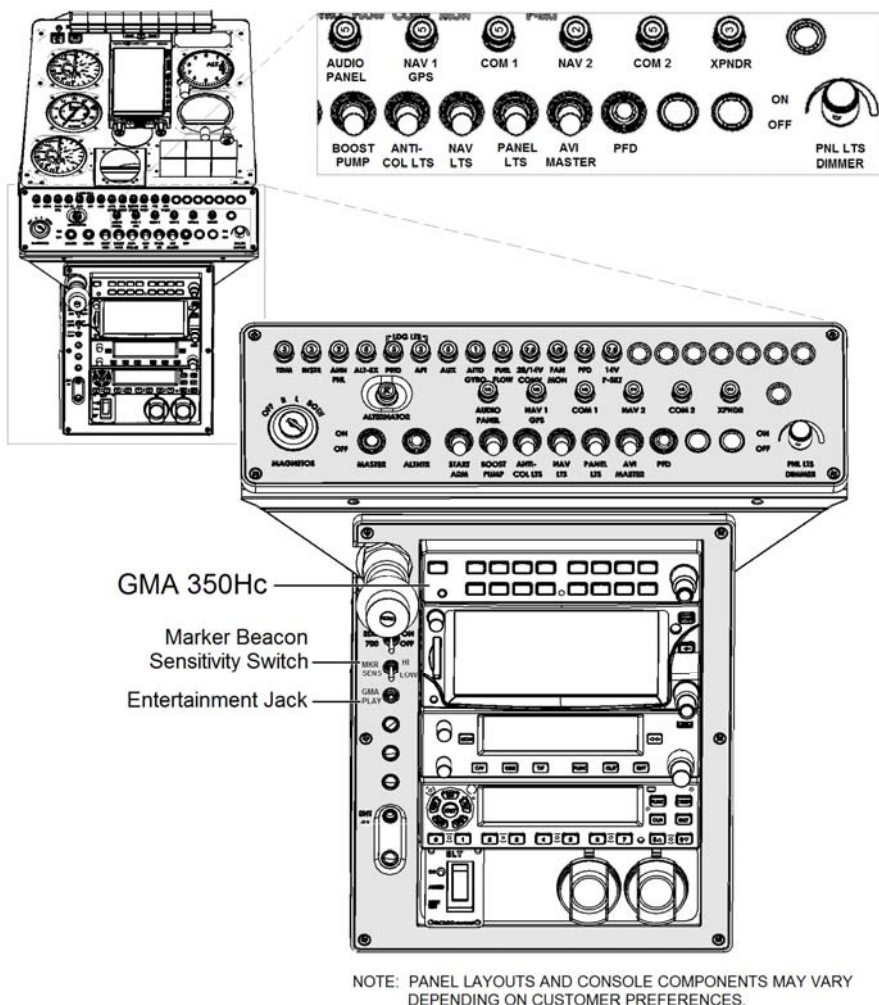

Figure 7-1. GMA 350Hc Installation

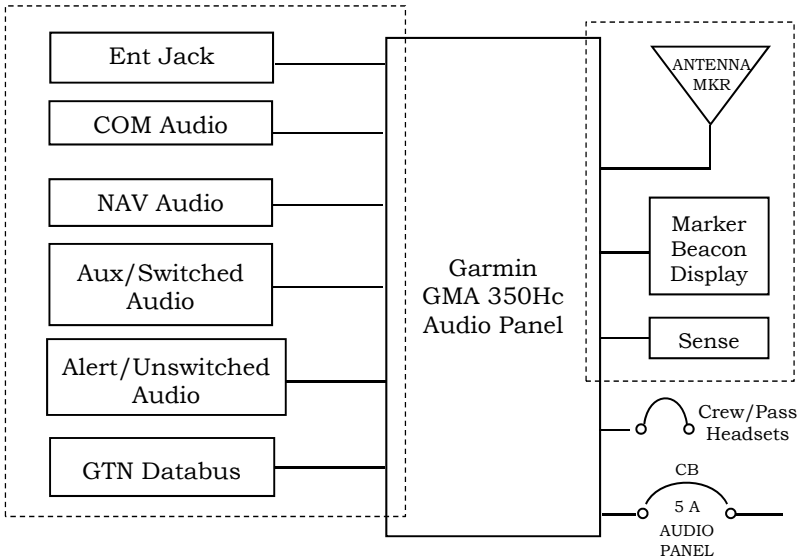

Figure 7-2. GMA 350Hc System Block Diagram (system options indicated with dashed outline)

7-2. General Operation

The following content covers basic operational procedures. Refer to the GMA 350H/350Hc Pilot's Guide for additional operational procedures (para. 1-2).

7-3. Power-Up

1. The GMA 350Hc is powered on when the avionics master switch (**AVI MASTER**) is turned on.
2. The GMA 350Hc performs a self-test during power-up. All audio panel annunciator lights will illuminate for approximately two seconds during the self-test.
3. After a complete self-test, most of the settings are restored to those in use before the unit was last turned off.

7-4. Controls

The audio panel controls are shown in Figure 7-3. The functions of the audio panel controls are summarized in Table 7-1. When a key is selected, the annunciator above the key is illuminated.



Figure 7-3. GMA 350Hc Controls

7-5. Transceivers

1. Press the **COM1**, **COM2**, or **COM3** key to select audio from the respective COM receiver.
2. Press the **MIC1**, **MIC2**, or **MIC3** key to transmit from the respective transmitter. The related COM receiver is simultaneously selected. The other COM receiver(s) can be added by pressing the respective key(s). During COM transmission, the active transceiver key annunciator flashes.
3. Select a second **MIC** key to transmit over separate radios (Split-COM operation). During Split-COM operation, the pilot transmits on the lower-numbered COM and the copilot transmits on the higher-numbered COM. Also, during Split-COM transmission, the respective **MIC** annunciator flashes when the PTT is pressed. Press one of the **MIC** keys to cancel Split-COM operation.
4. Press and hold **COM1** or **COM2** to enable/disable monitored COM muting during reception of audio from the COM radio selected for transmission. The aural message “**Monitor Mute Enabled/Disabled**” is heard.

7-6. Receivers

1. Press the NAV1 and/or NAV2 keys to select audio for the respective navigation radio source.

7-7. Marker Beacon Receiver (If Configured)

1. Press the **MKR/MUTE** key to activate marker beacon audio. The **MKR/MUTE** annunciator will illuminate during reception. Press the **MKR/MUTE** key twice to deactivate marker beacon audio.
2. During marker beacon audio reception, press the **MKR/MUTE** key to mute the audio. The **MKR/MUTE** annunciator remains lit, but the current marker tone is silenced. Audio muting deactivates automatically and marker beacon audio is heard when the next marker beacon signal is received.
3. Toggle the **MKR SENS** to **HI** or **LO** to select the desired audio sensitivity.

7-8. Intercom System

1. Press the **PILOT**, **COPLT**, and/or **PASS** keys to distribute audio as required. The associated annunciators illuminate indicating shared intercom audio.
 - a. If an annunciator is not lit, that position is isolated from the others. Refer to the GMA 350H/350Hc Pilot's Guide for selecting various isolate configurations.

7-9. Volume Adjustment



Turning the outer **VOL** control knob activates and moves the cursor (flashing green annunciator) to select the audio source for volume adjustment. Turning the inner **VOL** control knob adjusts the volume or manual squelch for the selected audio source. The cursor will cancel after a few seconds if there is no input and default to the **PILOT** key. Likewise, pressing the **VOL** knob while the cursor is flashing cancels the cursor. If the **VOL** knob is pressed twice, Blue-Select Mode will be activated.

Press the **VOL** knob again to cancel Blue-Select Mode. Blue-Select Mode is explained in paragraph 7-11.

Volume adjustment for the audio functions is as follows:

1. Intercom Volume
 - a. Turn the **CRSR** knob to activate and/or move the cursor over **PILOT**, **COPLT**, or **PASS**. Turn the **VOL** knob to adjust the intercom volume for the listener.
2. Manual Squelch
 - a. Turn the **CRSR** knob to activate and/or move the cursor over **MAN SQ**. Turn the **VOL** knob to adjust the ICS squelch threshold.
3. Marker Beacon, Music, and Aux Volume
 - a. Turn the **CRSR** knob to activate and/or move the cursor over **MKR**, **AUX**, , or **MUS**. Turn the **VOL** knob to adjust the volume of the selected source.

7-10. Entertainment Inputs

1. Press the  key to enable audio from a telephone or entertainment device connected to the front panel jack or one of the jacks on the copilot side pedestal.
2. Press the **MUS** key to toggle entertainment audio.
3. Distribution of the entertainment inputs using Blue-Select Mode is discussed in paragraph 7-11.
4. Telephone and entertainment audio is always muted during alerts. At any other time, muting can be enabled or disabled by pressing and holding the **MUS** or  key for two seconds. The aural message “**Mute 1 Music Enabled/Disabled**”, or “**Tel Mute Enabled/Disabled**” or “**Bluetooth Mute Enabled/Disabled**” is heard.

7-11. Bluetooth

1. Pairing a Bluetooth device:
 - a. Press and hold the inner knob for two seconds. The Bluetooth Annunciator flashes to indicate the unit is discoverable and the aural message “**Bluetooth discoverable**” is heard. Once paired, the Bluetooth annunciator turns steady green and the aural message “**Bluetooth paired**” is heard.
2. Assigning an Audio Source to the Bluetooth Device:
 - a. Press the  or **MUS** key until the annunciator turns blue. The key annunciator cycles OFF-GREEN-BLUE. GREEN selects the wired source. BLUE selects the Bluetooth source.

Refer to the GMA 350H/350Hc Pilot’s Guide for additional Bluetooth operation.

7-12. Recorder

The GMA 350Hc contains a digital clearance recorder that records up to 2.5 minutes of the selected COM radio signal. Refer to the GMA 350H/350Hc Pilot’s Guide for recorder operation.

7-13. Voice Recognition

NOTE



Voice Recognition is not authorized for helicopters registered in countries that recognize approvals granted by EASA.

The GMA 350Hc contains a Voice Recognition feature that allows the pilot or copilot to control the GMA 350Hc using spoken commands. This feature is activated by holding the cyclic trigger switch at the first detent. Refer to the GMA 350H/350Hc Pilot’s Guide for Voice Recognition operation.

7-14. 3D Audio

The GMA 350Hc features 3D Audio processing that is useful when multiple audio sources are present. Refer to the GMA 350H/350Hc Pilot’s Guide for 3D Audio operation.

Table 7-1. GMA 350Hc Controls

1	MRK MUTE	1. Selects the marker beacon receiver audio 2. Mutes the marker beacon receiver audio
2	COM1	1. Selects audio from #1 COM receiver 2. Press and hold to enable/disable monitored COM muting
3	COM2	1. Selects audio from #2 COM receiver 2. Press and hold to enable/disable monitored COM muting
4	COM3	1. Selects audio from #3 COM receiver 2. Press and hold to enable/disable monitored COM muting
5	NAV1	Selects audio from #1 NAV receiver
6	AUX	Selects audio from AUX inputs
7		1. Assigns the Bluetooth device to the  audio source 2. Press  until it cycles OFF to GREEN to BLUE (see also Note 1)
8	MUS	1. Assigns the Bluetooth device to the MUS audio source (see also Note 1) 2. Press the MUS key until the annunciator turns blue
9	MAN SQ	Select/deselect manual squelch
10	--	Indicates volume/squelch setting
11	--	Front panel entertainment/telephone jack
12	MIC1	Selects #1 transmitter (COM1 receive)
13	MIC2	Selects #2 transmitter (COM2 receive)
14	MIC3	Selects #3 transmitter (COM3 receive)
15	NAV2	Selects audio from #2 NAV receiver
16	PILOT	Controls the pilot ICS
17	COPLT	Controls the copilot ICS
18	PASS	Controls the passenger ICS
19	SPKR	(Not available)
20	CRSR	Activates and/or moves cursor (turn outer knob)

21	VOL	1. Turn inner knob to control volume or squelch of the selected source 2. Press and Hold for two seconds to enable the GMA 350Hc as discoverable for pairing (see Item 22)
22	--	A flashing blue annunciator indicates the unit is discoverable. A solid blue annunciator indicates an active Bluetooth connection.
Notes 1. See the GMA 350Hc Pilot's Guide for additional information regarding GREEN and BLUE annunciation and audio source selection.		

INTENTIONALLY LEFT BLANK