



PROPER CLEANING AND SERVICE OF CLUTCH SUPPORT AND INTERNAL DRIVE SHAFT SUPPORT BEARINGS.

BACKGROUND: To ensure proper servicing and cleaning of the overrunning clutch and internal drive shaft systems after failure of the ECD4014 or ECD4017 bearings.

PROCEDURE:

- 5-1. In the event of an ECD4014 or ECD4017 bearing failure, (overrunning clutch support bearing and internal drive shaft support bearings), it is important to change both bearings and perform the proper cleaning procedures.
- 5-2. If an ECD4014 or ECD4017 bearing is replaced due to damage to the bearing and if there is metal contamination present, both bearings must be changed.
- 5-3. In addition, the following steps must be taken to ensure that the system has been cleaned of all metal contamination.
 - A. Remove the overrunning clutch assembly, the internal drive shaft, the oil reservoir and associated oil lines between the clutch assembly and the reservoir.
 - B. Clean the engine internal PTO drive shaft and the engine bearing pads making sure to remove all traces of metal contamination.





Customer Support Work aid Document

Aircraft Type: TURBINE
Effectivity: ALL
Model (S): ALL

- C. Disassemble the sprag clutch assembly in accordance with the instructions in section 11-7 of the TH-28/480 Maintenance manual and the instructions in the Sprag Clutch Maintenance Work Aid Document

- a. Clean the clutch sprag assembly in accordance with the instructions in the Sprag Clutch Maintenance Work Aid Document.



- b. Clean inside the clutch housing and shaft assembly.
c. Assemble the clutch assembly and install a new ECD4014 bearing in accordance with instructions in the Sprag Clutch Maintenance Work Aid Document and section 11-7 in the maintenance manual.

- D. Disassemble the internal drive shaft assembly in accordance with section 11-7 of the TH-28/480 Maintenance manual.

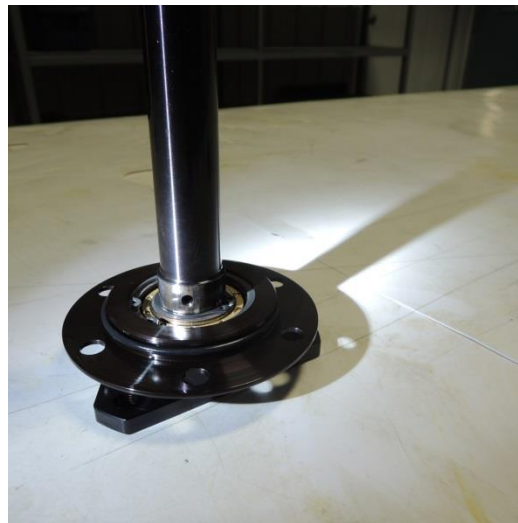



Customer Support Work aid Document

Aircraft Type: TURBINE
Effectivity: ALL
Model (S): ALL

- d. Clean the shaft and housing assembly paying particular attention to the inside of the drive shaft assembly.
- e. A brush for cleaning the inside of the drive shaft can be fabricated from a small piece of scotch brite and some 041 safety wire.



- f. Pay particular attention to the inside of the drive shaft assembly and the lubrication passage holes at the coupling end of the shaft.
- g. Assemble the internal drive shaft with a new ECD4017 bearing in accordance with section 11-7 of the maintenance manual.

E. Internally clean the reservoir and flush the oil lines to remove all traces of contamination.

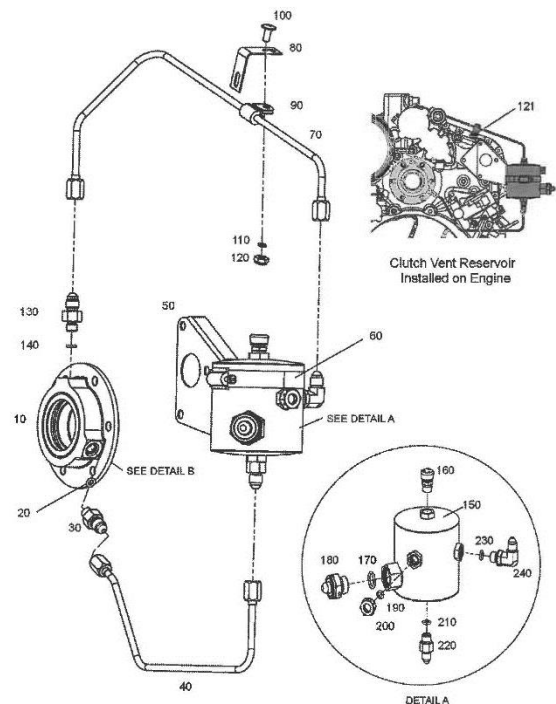



ENSTROM
HELICOPTER CORPORATION

2209 22nd Street EnstromHelicopter.com
Menominee, Michigan P 906-863-1200
49858 USA f 906-863-6821

Customer Support Work aid Document

Aircraft Type: TURBINE
Effectivity: ALL
Model (S): ALL

- F. Install the Clutch, internal drive shaft, and reservoir in accordance with sections 11-4 through 11-14 of the maintenance manual.
- G. Service the overrunning clutch system in accordance with section 4-10 of the maintenance manual.