



# SERVICE INFORMATION LETTER

---

---

SERVICE INFORMATION LETTER NO.0153

Page 1 of 12

DATE: February 15, 2002

1. SUBJECT: Tail Rotor Assembly, P/N 28-150000, Configurations
2. MODEL: F-28C, 280C, F-28F, 280F, and 280FX
3. EFFECTIVITY: All serial numbers
4. BACKGROUND:

There are three approved configurations of the 28-150000 Tail Rotor Assembly (Refer to Figures 1 and 2):

The 28-150000-7 Tail Rotor Assembly is a two bladed, wide cord, teetering, delta hinged rotor system. The tail rotor assembly consists of two blade and grip assemblies each mounted on a common spindle by a set of 3 thrust bearings with the inboard bearing thrust load reversed. This assembly is teeter-mounted on a center hub by non-lubricated slide bearings.

The 28-150000-9 Tail Rotor Assembly is similar to 28-150000-7 Tail Rotor Assembly except for the retention plate used on the blade and grip assemblies.

The 28-150000-10 Tail Rotor Assembly is similar to 28-150000-9 Tail Rotor Assembly except the blade and grip assemblies are mounted on the common spindle with a matched pair of DT thrust bearings and one needle bearing.

One of the problems with the 28-150000-7 and -9 tail rotor assemblies is excessive wear on the inboard thrust bearing of the ECD035-11 bearing set. A complete ECD035-11 bearing set must be installed when the inboard thrust bearing is replaced even though the outboard thrust bearings are normally in serviceable condition. Modification of the 28-150000-7 or -9 tail rotor assembly to a 28-150000-10 tail rotor assembly improves serviceability and significantly reduces the cost of maintaining the tail rotor assembly.

This Service Information Letter (SIL) provides instructions for changing the tail rotor assembly to a 28-150000-10 configuration and current part number information for the 28-150000-7, -9, and -10 tail rotor assemblies.

February 15, 2002

**5. COMPLIANCE:**

Use the procedure in paragraph 5-1 to modify the tail rotor assembly from a -7 or -9 configuration to a -10 configuration.

**NOTE**

Both feathering axes of the tail rotor assembly must have the same part number configuration.

Refer to paragraph 5-2 for the latest part number information for the 28-150000-7, -9, and -10 configurations.

**5-1. MODIFICATION:**

A. 28-150000-7 and -9 DISASSEMBLY: (Refer to Figure 1)

**NOTE**

Except for the following specific procedures, perform all maintenance in accordance with the applicable aircraft maintenance manual.

1. Remove the tail rotor assembly from the aircraft.
2. Secure the tail rotor assembly in a vise equipped with brass jaw protectors. Clamp the tail rotor assembly by the flat surfaces of the spindle so that the blade and grip assembly pointed down can be rotated.

**NOTE**

The following procedures are for the blade and grip assembly pointed down as installed in the vise.

3. Remove the lock wire from the bolts (22) in the retention plate (8) and remove the bolts.
4. Remove the grease fitting (18) from the blade grip and loosen the nuts on the bolts securing the tail rotor blade in the blade grip.

**CAUTION**

Do not tap on the root of the blade during the removal process or remove the blade from the blade grip.

**WARNING**

**Use caution when removing or installing the heated blade and grip assemblies to prevent injury.**

**WARNING**

**Use protective gloves when handling heated parts.**

5. Using a heat gun, heat the blade grip to approximately 250EF/121EC.
6. Remove the blade and grip assembly (16) by pulling on the blade with one hand and tapping on the blade bolt nuts with a nylon hammer.
7. Remove the lock washer (15) by prying up on the tabs with a screw driver.
8. Remove the nut (14) from the spindle using tool T-0056.

**NOTE**

The thrust bearings are matched sets.

9. Remove the outboard thrust bearings (11) from the spindle.
  10. Remove the spacers (12 & 13) from the spindle.
  11. Remove the inboard thrust bearing (11) from the spindle.
  12. Remove the retention plates (8 & 9) (-7 assembly only) from the spindle.
  13. Remove the spacer (10) from the spindle.
  14. Rotate the tail rotor assembly in the vise and disassemble the opposite side of the tail rotor assembly.
- B. 28-150000-10 ASSEMBLY: (Refer to Figure 2)

**NOTE**

Except for the following specific procedures, perform all maintenance in accordance with the applicable aircraft maintenance manual.

**NOTE**

The retention plate (8) used on the -10 assembly is the same as on the -9 assembly.

1. Install the retention plate (8) on the spindle with the machined clearance surface of the plate facing outboard (toward the blade grip).
2. Install the bearing sleeve (9) onto the spindle.

**NOTE**

The "shouldered end" of the retainer faces outboard toward the thrust bearings.

3. Press the bearing (10) into the bearing retainer (11) and install on the bearing sleeve.

**NOTE**

The two outboard thrust bearings of the ECD035-11 bearing set (-7 and -9 assembly) are the same as the ECD002-11 bearing set. If the outboard bearings from the ECD035-11 bearing set are serviceable, they may be used in place of the ECD002-11 bearing set.

4. Install the thrust bearings (12) in matched sets with the closed side of the bearing facing inboard toward the hub. This side of the bearing will also have the word "thrust" imprinted on the face of the outer race. Most of these bearing sets will be scribed with a "V" on the outer races pointing toward the center hub.
5. Install the retaining nut (13) using tool T-0056 and torque to 80-90 ft-lbs/109.1-122.7 Nm.

**NOTE**

The torque on the retaining nut is significantly increased from previous torque requirements in the applicable maintenance manuals.

6. Align and install the lock washer (14).
7. Install the bumper (15) onto the end of the spindle.
8. Lubricate the O.D. of the bearings with a mixture of STP and 30 Weight oil. Apply a small amount of Lubriplate (L0067-001) onto the end of the bumper.

**WARNING**

**Use caution when removing or installing the heated blade and grip assemblies to prevent injury.**

**WARNING**

**Use protective gloves when handling heated parts.**

9. Using a heat gun, heat the blade grip to approximately 250EF/121EC.

**NOTE**

The following two steps should be performed quickly before the blade grip cools appreciably.

10. Lubricate the bore of the blade grip with the STP and oil mixture. Slide the blade and grip assembly onto the spindle. Align the pitch link hole in the retention plate to the leading edge of the blade. Align the dowel pins to the center holes in the retention plate (the holes are located in sets of three).
11. Start three bolts (22) into the grip and alternately tighten the bolts 1 to 2 turns to pull the grip and the retention plate together.
12. Install the remaining bolts (22). After the blade and grip assembly has cooled, torque the bolts to 50-70 in-lbs/5.7-8.0 Nm and lock wire (MS20995C32) in pairs.
13. Re-heat the blade grip and tap the blade grip outboard to move it to the maximum CF (centrifugal force) position.
14. Torque the blade retention bolt nuts to 70 in-lbs/8.0 Nm for 1/4 inch bolts or 140 in-lbs/15.9 Nm for 5/16 inch bolts after the blade grip has cooled.
15. Install the grease fitting (18) into the grip and lubricate the grip until grease purges from the retention plate around the spindle.

**NOTE**

Enstrom recommends lubricating the tail rotor blade grips with grease conforming to MIL-PRF-81322 (formerly MIL-G-81322). Refer to SIL 0137 for other approved lubricants for the tail rotor assembly.

16. Rotate the tail rotor assembly in the vise and assemble the opposite side.

February 15, 2002

- 17. Statically balance the tail rotor.
- 18. Install the tail rotor assembly.
- 19. Dynamically balance the tail rotor assembly.

5.2. PARTS:

- a. Refer to Figure 1 for 28-150000-7 and -9 tail rotor assemblies and Figure 2 for a 28-150000-10 tail rotor assembly.
- b. Refer to the following table for consumable items.

Description	Part Number	Quantity
Lock wire	MS20995C32	As Required (A/R)
Lubriplate, 630-AA	L0067-001	A/R
Engine Oil, 30 Weight	No Part Number (NPN)	A/R
STP®	NPN	A/R

6. SPECIAL TOOLS:

Description	Part Number
Tail Rotor Input Nut Socket	T-0056

- 7. MAN-HOURS: 4 Man-hours for modifying the tail rotor assembly to 28-15000-10 configuration.
- 8. WARRANTY: Per Enstrom warranty policy
- 9. WEIGHT CHANGE: Add 1.0 pound at station 320.0 when converting from a 28-150000-7, or -9 tail rotor assembly to a 28-150000-10 tail rotor assembly.
- 10. LOG BOOK ENTRY: Enter compliance with this SIL when converting the tail rotor assembly from 28-150000-7, or -9 to 28-150000-10 configuration.
- 11. REPETITIVE INSPECTION:  
Inspect tail rotor assembly in accordance with the applicable aircraft maintenance manual.

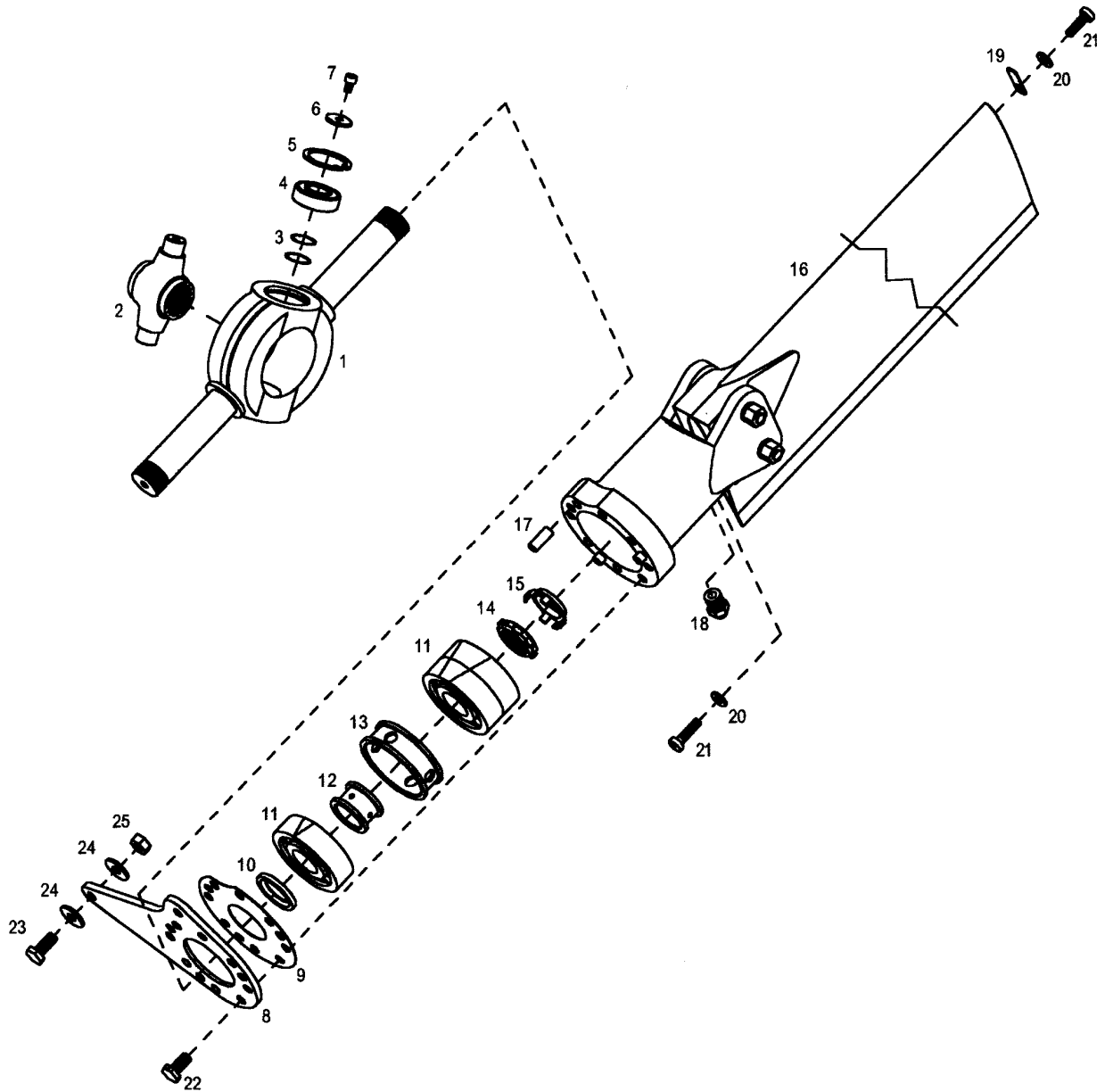

Figure 1. Tail Rotor Assembly, P/N 28-150000-7, & -9

February 15, 2002

FIGURE 1. TAIL ROTOR ASSEMBLY, P/N 28-150000-7, &amp; -9

ITEM NUMBER	PART NUMBER	DESCRIPTION	QTY PER ASSY	MODELS AFFECTED						
				F28A	280	F28C	280C	F28F	280F	280FX
-	28-150000-7	. Tail Rotor Assembly	1			X	X	X	X	X
-	28-150000-9	. Tail Rotor Assembly	1			X	X	X	X	X
1	28-150014-13	. . Spindle	1			X	X	X	X	X
2	28-15206-1	. . Hub	1			X	X	X	X	X
3	28-15203-3	. . Shim, .001"	A/R			X	X	X	X	X
3	28-15203-4	. . Shim, .002"	A/R			X	X	X	X	X
3	28-15203-5	. . Shim, .003"	A/R			X	X	X	X	X
3	28-15203-6	. . Shim, .005"	A/R			X	X	X	X	X
3	28-15203-7	. . Shim, .0005"	A/R			X	X	X	X	X
4	KRP8A-H	. . Bearing	2			X	X	X	X	X
5	N5000-112-PP	. . Retaining Ring	2			X	X	X	X	X
6	28-14120-11	. . Washer	2			X	X	X	X	X
7	MS21262-6	. . Screw	2			X	X	X	X	X
8	28-150046-1	. . Retention Plate (-7 Assembly)	2			X	X	X	X	X
8	28-150060-11	. . Retention Plate (-9 Assembly)	2			X	X	X	X	X
9	28-150048-1	. . Retention Plate (-7 Assembly)	2			X	X	X	X	X
10	28-150026-1	. . Spacer	2			X	X	X	X	X
11	ECD035-11	. . Bearing Set	2			X	X	X	X	X
12	28-150016-11	. . Spacer	2			X	X	X	X	X
13	28-150015-11	. . Spacer	2			X	X	X	X	X
14	SL61N-5P	. . Nut	2			X	X	X	X	X
15	SL61W-5P	. . Washer	2			X	X	X	X	X
16	28-150001-5	. . Tail Rotor Blade and Grip Assembly	2			X	X	X	X	X
17	28-150044-5	. . . Dowel Pin	3			X	X	X	X	X
18	1650	. . Lube Fitting	2			X	X	X	X	X
19	28-17308-1	. . Strike Tab	2			X	X	X	X	X
20	AN960-10*	. . Washer	A/R			X	X	X	X	X
20	AN960-10L*	. . Washer	A/R			X	X	X	X	X
20	AN960D10*	. . Washer	A/R			X	X	X	X	X



February 15, 2002

FIGURE 1. TAIL ROTOR ASSEMBLY, P/N 28-150000-7, &amp; -9

ITEM NUMBER	PART NUMBER	DESCRIPTION	QTY PER ASSY	MODELS AFFECTED						
				F28A	280	F28C	280C	F28F	280F	280FX
20	AN960D10L*	. . Washer	A/R			X	X	X	X	X
21	AN520-10-"X" **	. . Screw	4			X	X	X	X	X
22	AN4H-4A	. . Bolt	16			X	X	X	X	X
23	AN4-4A	. . Bolt	2			X	X	X	X	X
24	¼ Harper	. . Harper Washer	4			X	X	X	X	X
25	AN364-428A	. . Nut	2			X	X	X	X	X

\* Use as required for statically and dynamically balancing the tail rotor assembly.

\*\* Adjust length as required for statically and dynamically balancing the tail rotor assembly.

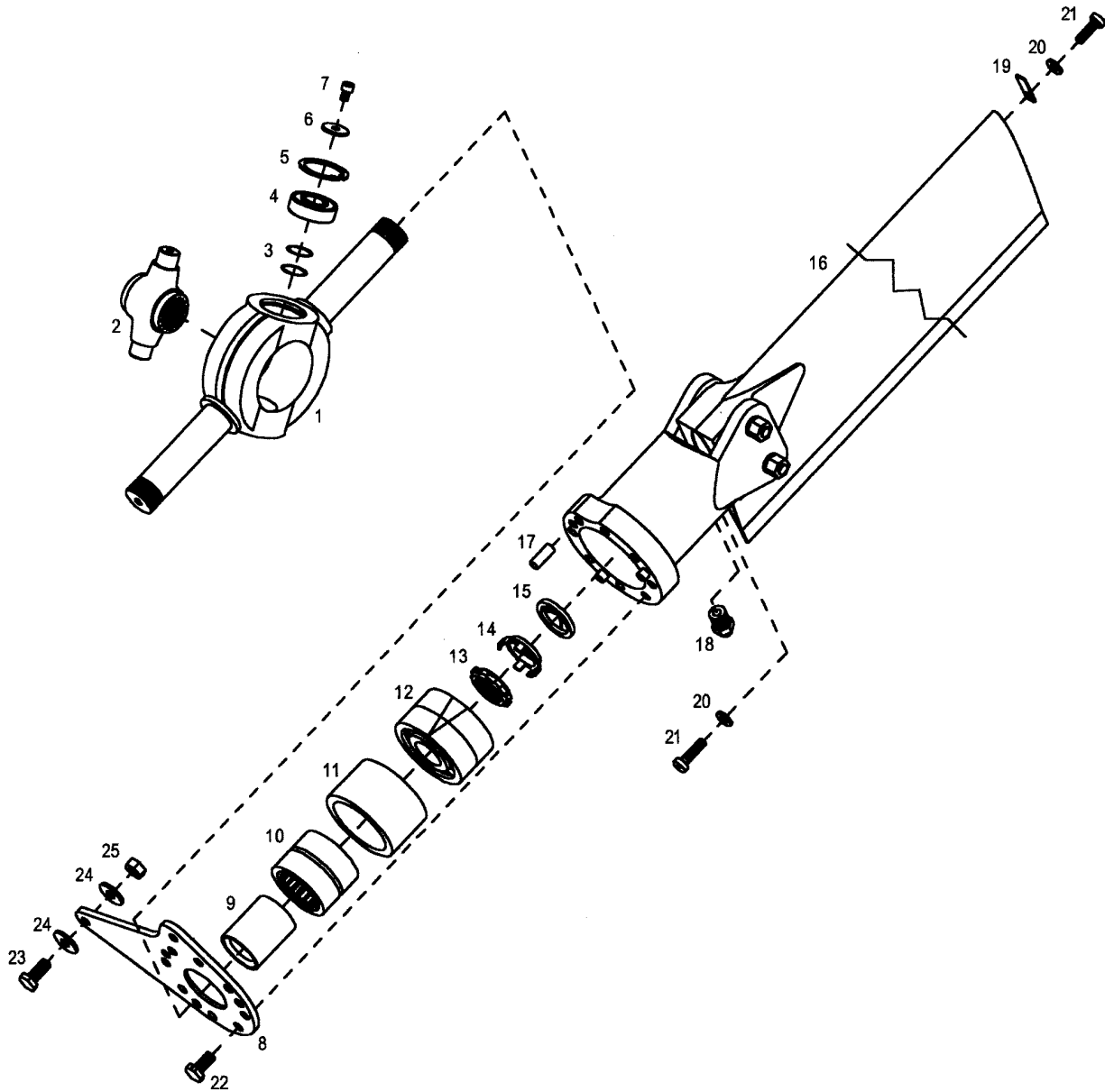

Figure 2. Tail Rotor Assembly, P/N 28-150000-10

February 15, 2002

FIGURE 2. TAIL ROTOR ASSEMBLY, P/N 28-150000-10

ITEM NUMBER	PART NUMBER	DESCRIPTION	QTY PER ASSY	MODELS AFFECTED						
				F28A	280	F28C	280C	F28F	280F	280FX
-	28-150000-10	. Tail Rotor Assembly	1			X	X	X	X	X
1	28-150014-13	. . Spindle	1			X	X	X	X	X
2	28-15206-1	. . Hub	1			X	X	X	X	X
3	28-15203-3	. . Shim, .001"	A/R			X	X	X	X	X
3	28-15203-4	. . Shim, .002"	A/R			X	X	X	X	X
3	28-15203-5	. . Shim, .003"	A/R			X	X	X	X	X
3	28-15203-6	. . Shim, .005"	A/R			X	X	X	X	X
3	28-15203-7	. . Shim, .0005"	A/R			X	X	X	X	X
4	KRP8A-H	. . Bearing	2			X	X	X	X	X
5	N5000-112-PP	. . Retaining Ring	2			X	X	X	X	X
6	28-14120-11	. . Washer	2			X	X	X	X	X
7	MS21262-6	. . Screw	2			X	X	X	X	X
8	28-150060-11	. . Retention Plate	2			X	X	X	X	X
9	28-150063-13	. . Bearing Sleeve	2			X	X	X	X	X
10	ECD001-15	. . Bearing	2			X	X	X	X	X
11	28-150055-13	. . Bearing Retainer	2			X	X	X	X	X
12	ECD002-11	. . Bearing Set	2			X	X	X	X	X
13	SL61N-5P	. . Nut	2			X	X	X	X	X
14	SL61W-5P	. . Washer	2			X	X	X	X	X
15	28-15033-15	. . Bumper	2			X	X	X	X	X
16	28-150001-5	. . Tail Rotor Blade and Grip Assembly	2			X	X	X	X	X
17	28-150044-5	. . . Dowel Pin	3			X	X	X	X	X
18	1650	. . Lube Fitting	2			X	X	X	X	X
19	28-17308-1	. . Strike Tab	2			X	X	X	X	X
20	AN960-10*	. . Washer	A/R			X	X	X	X	X
20	AN960-10L*	. . Washer	A/R			X	X	X	X	X
20	AN960D10*	. . Washer	A/R			X	X	X	X	X
20	AN960D10L*	. . Washer	A/R			X	X	X	X	X
21	AN520-10-"X" **	. . Screw	4			X	X	X	X	X

February 15, 2002

FIGURE 2. TAIL ROTOR ASSEMBLY, P/N 28-150000-10

ITEM NUMBER	PART NUMBER	DESCRIPTION	QTY PER ASSY	MODELS AFFECTED						
				F28A	280	F28C	280C	F28F	280F	280FX
22	AN4H-4A	. . Bolt	16			X	X	X	X	X
23	AN4-4A	. . Bolt	2			X	X	X	X	X
24	¼ Harper	. . Harper Washer	4			X	X	X	X	X
25	AN364-428A	. . Nut	2			X	X	X	X	X

\* Use as required for statically and dynamically balancing the tail rotor assembly.

\*\* Adjust length as required for statically and dynamically balancing the tail rotor assembly.