



SERVICE INFORMATION LETTER

SERVICE INFORMATION LETTER NO. 0110

REVISION B

Page 1 of 3

DATE: March 18, 1993

SUBJECT: Swashplate Lubrications

MODELS: F28A, 280, F28C, F28C-2, and 280C Models Manufactured Prior to January, 1981

REFERENCE: Enstrom Service Bulletin No. 0035 "Upper Swash Plate Bearing" and FAA Airworthiness Directive 76-06-11

The requirement for hand packing of the upper and lower swashplate bearing can be eliminated incorporating the following modification.

The upper swashplate bearing housing P/N 28-16108-1, and the lower swashplate bearing housing P/N 28-16361-1, have been modified for a grease fitting installation. This modification also includes, as an integral part, special bearing shields that will prevent water entering the bearing assemblies during flight or outside storage.

NOTE: This WILL NOT delete the use of the hub cover on helicopters that are parked or stored outside and exposed to the elements.

This modification will allow for easy servicing of these bearings and assure the operator the maximum service life of this assembly with minimal maintenance man-hours. It is therefore recommended that this modification be installed at the operator's earliest convenience or at the next 100 hour inspection.

NOTE: Those craft in compliance with this Service Information Letter No. 0110 Revision A, are exempt from FAA Airworthiness Directive 76-06-11 and Enstrom Service Directive Bulletin No. 0035.

For swashplate disassembly and assembly instructions, refer to the F28A or 280 Enstrom Maintenance Manual pages MM-11-14 thru MM-11-20. Refer to Maintenance Manual illustration, Fig. A and A-1 and the following, for modification instructions. Except as noted below, reassembly of the swashplate assemblies is unchanged.

1. Parts called out for removal and installation are as follows: (Ref. MM-11-17)
 - (a) Remove item (47); replace with P/N 28-16106-2
 - (b) Remove item (36); replace with P/N 28-16108-2
 - (c) Remove item (2); replace with P/N 28-16361-1
 - (d) Bearings, items (29) and (48), should be inspected for serviceability (i.e., smooth and tight). If found acceptable, may be reinstalled and replaced on condition per this Service Letter.

NOTE: Before bearing installation, the plastic bearing shield on one side of both bearings must be removed.

2. On reassembly, install the following during assembly sequence. (Ref. MM-11-17 or MM-11-16). Note that on bearing installation, the side with the shield removed must be on top.
 - (a) With bearing (48) installed in bearing housing (36) place bearing shield over bearing and secure by pressing spacer (47) into bearing.
 - (b) Install seal retainer P/N 28-16389-2 (Ref. Fig. A) between shims and bearing retainer (46).
 - (c) Install lower bearing shield P/N 28-16387-1 between spacer P/N 28-16228-1 (Ref. Fig. A) and bearing housing (2).
 - (d) Install lube fittings P/N 1911B-1 in upper and lower bearing housings as shown in Fig. A-1.

These bearings can be serviced with Exxon ANDOK-B or any MIL-G-18709A type grease.

The following parts list is required to complete this modification and may be ordered through Enstrom Customer Service.

ITEM	PART NUMBER	PART NAME	QTY
1	28-16108-2	Bearing Housing - Upper	1
2	28-16106-2	Spacer - Upper	1
3	28-16386-1	Bearing Shield - Upper	1
4	28-16389-2	Seal Retainer - Upper	1
5	28-16381-1	Bearing Shield - Lower	1
6	28-16361-1	Bearing Housing - Lower	1
7	*Z993L13X3B	Bearing	1
8	**5201SBKZZ-ABEC	Bearing	1
9	1911B-1	Lube Fitting	2

NOTE: Alternate lower bearing housing can be a modified 28-16122-1, EO. 1-R

* Alternate bearing No. SKF 6013-RS - Enstrom part No. ECD013-13

** Enstrom part No. is ECD013-13

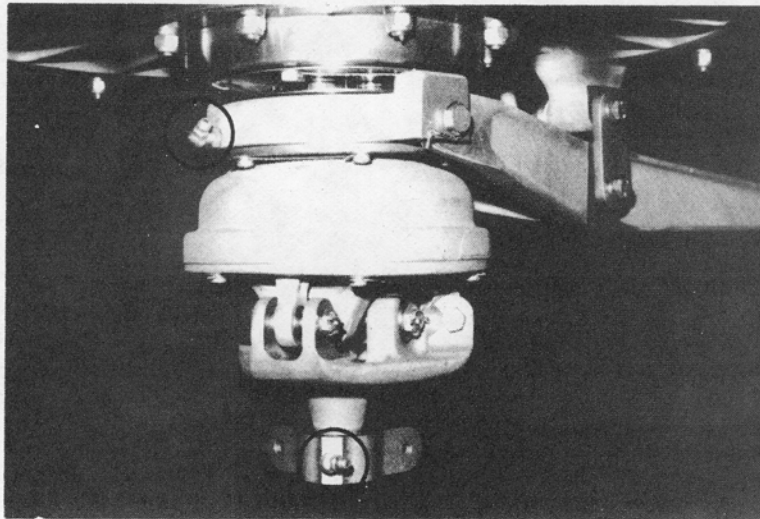
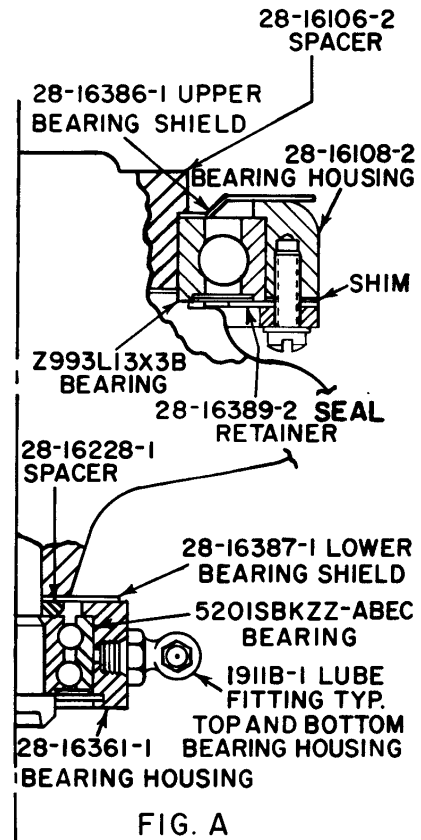

FIG. A-1



NOTE: OPEN SIDE OF BEARINGS ON TOP FOR GREASE ENTRANCE.