



# SERVICE INFORMATION LETTER

---

---

SERVICE INFORMATION LETTER NO. 0091

Rev. A - Supercedes 0091 Page 1 & 2

Page 1 of 3

Date: September 26, 1980

Subject: Modification to Engine Starting System

Models F-28C prior to S/N 480 (except S/N 465); 280C prior to S/N 1183 (except S/N 1172)

Effectivity: As noted below

To improve the reliability of the starter and the starting characteristics of the Enstrom helicopter, the Bendix Model D2000 magneto has been replaced with Bendix Model D2200 magneto (P/N LW-385144-112) or 3000 series (P/N LW-682605-17) which utilize the electric retard (shower of sparks) starting system. The shower of sparks system provides more reliable starting and reduces the possibility of engine kick back, which has damaged some starter Bendix assemblies.

All Enstrom turbocharged helicopters may be retrofitted to the shower of sparks starting system. it is recommended that this modification be made at the next scheduled magneto replacement or overhaul. When this modification has been completed, a log book entry must be made and the engine plate will be changed to read "E1BD". New nameplates are available from Lycoming. Refer to Lycoming Service Instruction I304B before ordering.

Installation instruction for the new electrical panel and components are attached.

Bendix Special Instruction No. 214 for installation of breaker bushing in existing harness cover on the D2000/3000 series magnetos, is also included with kit 19-R0122. This change is a cost reduction allowing operator to use existing harness and cover.

All parts required for this modification may be purchased from Enstrom Customer Service. Specify kit No. 19-R0122.

INSTALLATION OF MODIFICATION TO THE ENGINE STARTING SYSTEM

1. Disconnect wires from the components on the 28-19004-1 standard mount plate (Ref. figure 1).
2. Remove 28-19004-1 mount plate and attached components.
3. Remove all components and hardware from 28-19004-1 mount plate.
4. Assemble 28-19016-1 mount plate and components (Ref. figure 2, page 3, and drawing 28-19122, dated 6/25/80, supplied with kit).
5. Relocate fuel line clamp and wire harness clamps (2) (Ref. figure 2).
  - (a) Disassemble clamp assembly and discard smallest harness clamp (retain larger harness clamp for reassembly).
  - (b) Slide fuel line clamp DOWN 3.75 inches. and use it as a guide to drill the new installation hole in the fire wall.
  - (c) Seal original mounting hole drilled in the firewall with (1) AN515-8R6 screw, (2) AN960-8L washers, and (1) AN363-832 nut. Install with bolt head on cabin side of firewall.
6. Separate existing wire harness back to the "P" leads 20-1 and 21-1 on the magneto.

NOTE: Remove wire 40-10 over voltage relay ground (figure 3).
7. Cut 20-1 and 21-1 approximately 6 inches away from the "P" lead terminal.

NOTE: Number the remaining wire bundle ends of these wires with the same numbers.
8. Renumber the 6 inch "P" lead pigtails 20-3 and 21-3 respectively.
9. Splice (use CSN-346 splice provided) wires 20-1 and 20-2 (supplied with wire harness P/N 28-19121) to 20-3.
10. Splice (use CSN-346 splice provided) wires 21-1 and 21-2 (supplied with wire harness P/N 28-19121) to 21-3.
11. Solder furnished retard lead terminal wire to 22-1 in wire harness P/N 28-19121.
12. Tie and clamp 28-19121 harness with existing main wire harness.
13. Install 28-19016-1 mount plate (Ref. figure 2).
14. Terminate wires per figure 3 and drawing 28-19122 supplied with kit.

NOTE: Wire 40-2 is grounded on the same lug as 40-4.

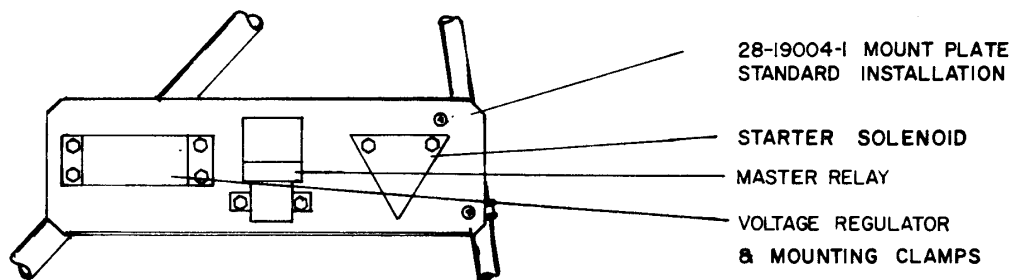

OLD INSTALLATION

FIG. 1

REPLACED BY THIS INSTALLATION.

① ADD WIRE BUNDLE 28-19121-1 PER SCHEMATIC BELOW.

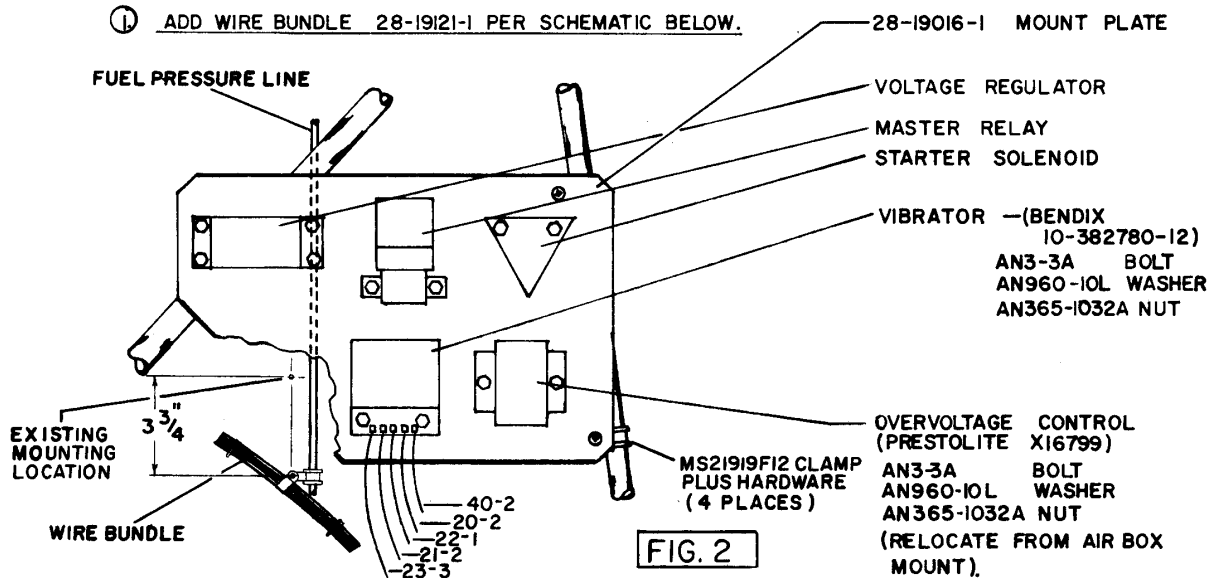

FIG. 2

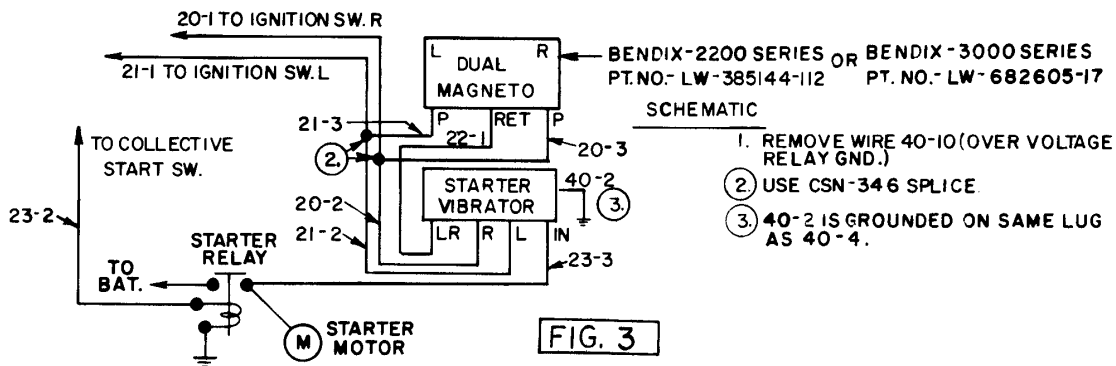
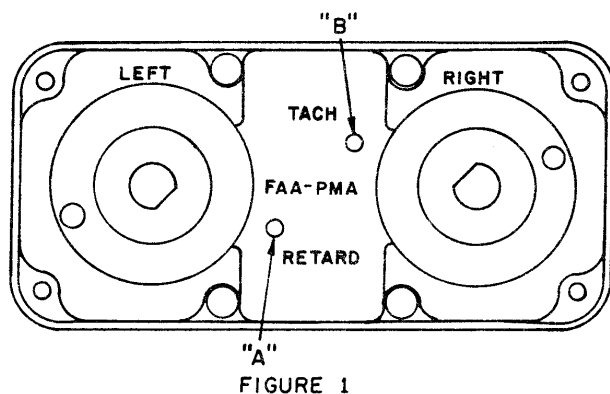

FIG. 3

Subject: Installation of Retard Breaker and/or Tachometer Breaker Bushings in D-2000/3000 Series Magneto Harness Cover.

Retard Bushing P/N 10-157155. Tachometer Bushing P/N 10-157154. This procedure is applicable to 4, 6, and 8 cylinder Harness Covers.



ASSEMBLY INSTRUCTIONS

- Step (1) Note recess in harness cover (Fig. 1) identified retard "A" or tach "B", drill hole diameter  $.344 \pm .005$  using an 11/32 drill bit.
- (2) To protect the magnesium housing, prior to pressing the bushing into the drilled hole place a support against the inside top of the harness cover. It is suggested that the support be a piece of pipe 6" long with an inside diameter of 9/16" cut square at both ends. Insure that the wall of the pipe is thick enough to support the cover when pressing, at least 1/8" thick.
- (3) Set the knurled end of the bushing into the hole, do not press bushing without first complying with Step #2.
- (4) Support pipe and harness cover on the arbor press pad. Insure that the inside diameter of the pipe surrounds the bushing to give support as the bushing is pressed into the cover. Place a wood block on the threaded end of the bushing and press until the bushing flange is seated against the harness cover.
- (5) Turn the harness cover upside down and rest threaded top of the bushing on the wood block to protect the threads. Holding the harness cover level, use a tapered drift of appropriate size to flair the bushing until the bushing is tight in the cover.
- (6) After flairing, use a drift of suitable size and peen over the flair of the bushing to the cover. CAUTION: Over flairing may deform the inside diameter of the bushing.
- (7) After completion of Step #6, visually inspect the bushing flange to insure that it is flush against the top of the harness cover 360 degrees.