



SERVICE DIRECTIVE BULLETIN

SERVICE NOTE NO. 0034

Page 1 of 2

Date: January 22, 1976

Subject: Copilot's Tail Rotor Pedal Clearance with the Defroster Installation Mount Bolt

Model: F-28A Only

Effectivity: Serial No. 75 thru 160

One occurrence has been reported of the copilot's left tail rotor pedal interference with the defroster mount bolt.

An immediate inspection per the outlined procedure is to be accomplished:

1. Push the tail rotor pedals to the full left position.
2. Push the inboard copilot's pedal laterally toward the center of the helicopter to take up system tolerances.
3. Maintaining hand pressure to the left, move the inboard or left tail rotor pedal aft to the stop. The minimum clearance is illustrated on page two, Figure No. 1, of this service note.
4. Items 1, 2, and 3 are to be repeated with the tail rotor pedal in all six of the foot adjustment positions.

F-28A helicopters of record with defroster systems installed are:

Serial Numbers 75, 107, 108, 114, 128, 132, 141, 144, 146, 147

It is required that all F-28A helicopters with serial numbers beginning with 75 and through 160 be inspected per this service note.

If any interferences are found, contact Enstrom Customer Service Department for replacement foot supports (2 required).

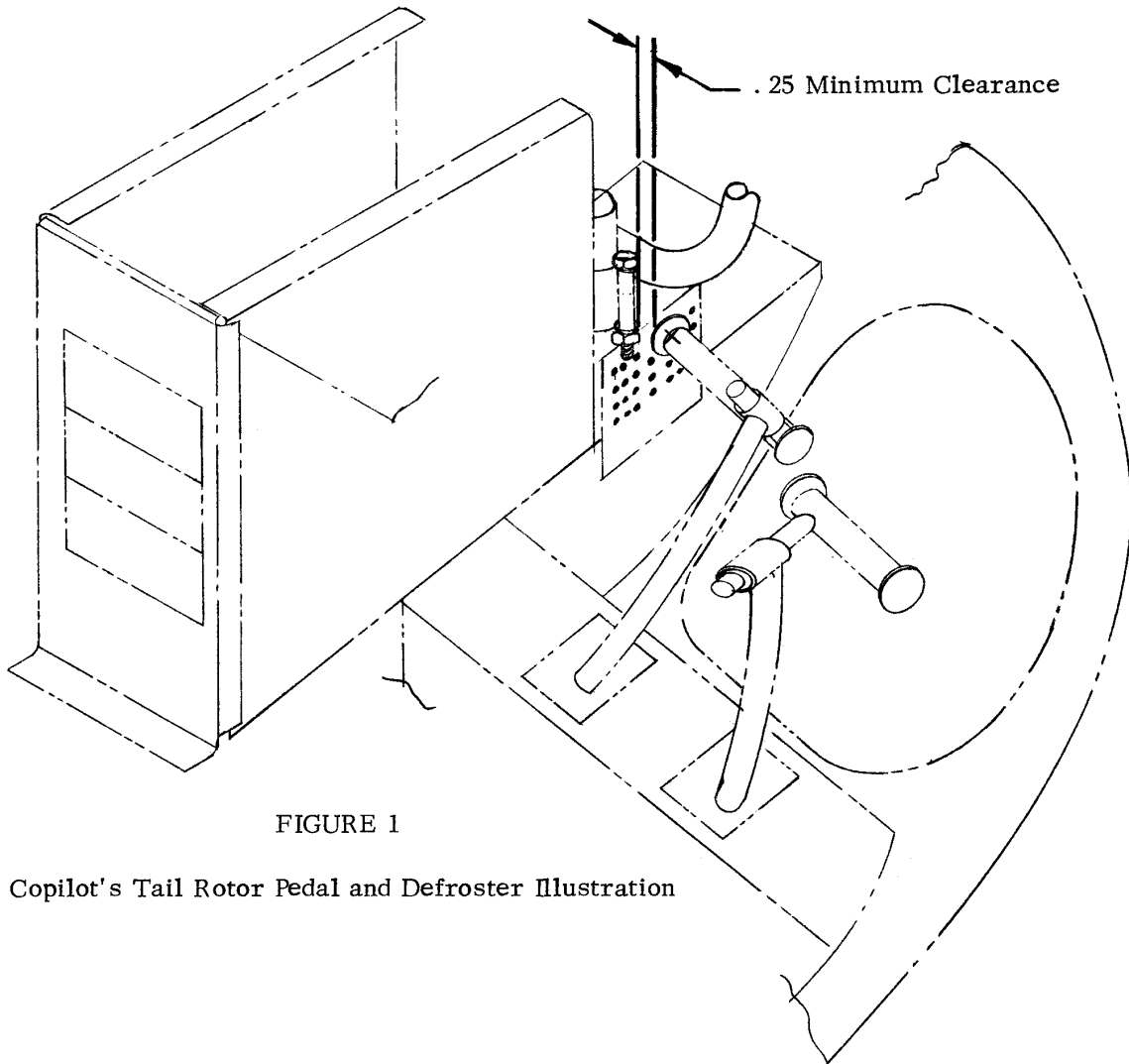

FIGURE 1

Copilot's Tail Rotor Pedal and Defroster Illustration