

### Record of Revisions

Revision Number	Issue Date	Date Inserted	By
22	7/16/15	9/24/15	JW
23	4/28/16	5/24/16	JW
24	5/2/19	7/15/19	JW

**Maintain this record in the front of the manual.**

This electronic document is not linked to a subscription for revision control or distribution. Refer to the Technical Publications Status link under the Technical Support Page of the Enstrom Helicopter website for the current revision level of the 480B Rotorcraft Flight Manual.



**ENSTROM 480B OPERATOR'S MANUAL**  
**AND**  
**FAA APPROVED**  
**ROTORCRAFT FLIGHT MANUAL**

\* \* \* \* \*

REPORT NO. 28-AC-023

TYPE CERTIFICATE NO. H1CE

HELICOPTER SERIAL NO. \_\_\_\_\_

HELICOPTER REGISTRATION NO. \_\_\_\_\_

\* \* \* \* \*

**THIS MANUAL MUST BE CARRIED IN THE  
HELICOPTER AT ALL TIMES. CHAPTERS 1, 2,  
3, 4, AND 5 ARE FAA APPROVED.**

FAA APPROVED BY: \_\_\_\_\_

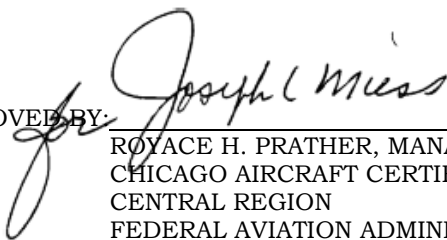

ROYACE H. PRATHER, MANAGER  
CHICAGO AIRCRAFT CERTIFICATION OFFICE  
CENTRAL REGION  
FEDERAL AVIATION ADMINISTRATION

FAA APPROVAL DATE: \_\_\_\_\_

FEB 9 2001

THE ENSTROM HELICOPTER CORPORATION  
2209 22<sup>ND</sup> STREET  
MENOMINEE, MICHIGAN 49858-3515

**INTENTIONALLY LEFT BLANK**

**LOG OF REVISIONS**

Rev. No.	Date	FAA Approved
1	April 10/02	Joseph C. Miess
2	Sept 05/03	Joseph C. Miess
3	Feb 2/04	Joseph C. Miess
4	Sep 9/04	Joseph C. Miess
5	Sep 27/04	Joseph C. Miess
6	Apr 11/05	Joseph C. Miess
7	Jun 6/06	Joseph C. Miess
8	Sep 17/06	Joseph C. Miess
9	Mar 6/07	Joseph C. Miess
10	Apr 11/07	Joseph C. Miess
11	Dec 5/07	Joseph C. Miess
12	Feb 14/08	Joseph C. Miess
13	Apr 23/08	Joseph C. Miess
14	Apr 16/10	Joseph C. Miess
15	Jul 16/10	Joseph C. Miess
16	Sep 20/10	Joseph C. Miess
17	Jan 25/11	Joseph C. Miess
18	Jul 15/11	M. W. Anderson
19	Jan 18/12	Joseph C. Miess
20	Jul 3/12	Joseph C. Miess
21	Jan 14/13	Joseph C. Miess
22	Aug 17/15	Ronald D. McElroy
23	May 19/16	Ronald D. McElroy
24	May 21/19	Ryan Nelson

**Approved by the Manager,  
Southwest Flight Test Section, AIR-713  
Federal Aviation Administration  
Ft. Worth, TX**

FAA Approved: May 21/19  
Report No. 28-AC-023

Rev. 24  
May 2/19

**EASA LOG OF REVISIONS**

Rev. No.	Date	EASA Approved	FAA Approval on Behalf of EASA
1	Sep 28/03	*	N/A
2	Sep 28/03	*	N/A
3	May 29/05	2005-4677	N/A
4	May 30/05	2005-4682	N/A
5	May 29/05	2005-4678	N/A
6	Jun 1/05	Decision 2004/04/CF	N/A
7	Jun 6/06	Decision 2004/04/CF	N/A
8	Sep 17/06	Decision 2004/04/CF	N/A
9	Aug 2/07	EASA.IM.R.C.01427	N/A
10	Jan 18/08	EASA.IM.R.C.01426	N/A
11	Apr 17/08	EASA.IM.R.C.01442	N/A
12	NOT EASA APPROVED (SUPP. #10, EFIS)		
13	NOT EASA APPROVED (SUPP. #10, EFIS)		
14	Apr 4/13	EASA 10044309	N/A
15	Mar 7/13	EASA 10043956	N/A
16	Jan 27/14	EASA 10045751	N/A
17	Aug 28/13	FAA/EASA T.I.P. **	G. J. Michalik
18	May 8/14	EASA 10044744	N/A
19	Aug 28/13	FAA/EASA T.I.P. **	G. J. Michalik
20	Oct 10/13	FAA/EASA T.I.P. **	G. J. Michalik
21	Jan 27/14	EASA 10045751	N/A
22	May 1/17	FAA/EASA T.I.P. **	M. Javed
23	May 1/17	FAA/EASA T.I.P. **	M. Javed
24	Jul 11/19	FAA/EASA T.I.P. ***	M. Javed

\* Article 3, Commission Regulation (EU) 748/2012

\*\* Section 3.2 T.I.P. Revision 5

\*\*\* Section 3.5.12 T.I.P. Revision 6

FAA Approved: May 21/19  
Report No. 28-AC-023Rev. 24  
May 2/19

**LOG OF SUPPLEMENTS**

Sup. No.	Description	Date	FAA Approved
1	Cargo Hook	Feb 9/01	Joseph C. Miess
2	Snow Shoes	Feb 9/01	Joseph C. Miess
3	External Fuel Filter	Feb 9/01	Joseph C. Miess
4	Baggage Box Extension	Feb 9/01	Joseph C. Miess
5	Camera Door	Feb 9/01	Joseph C. Miess
6	Emergency Floats	Sep 5/03	Joseph C. Miess
7	Air Conditioning	Sep 9/04	Joseph C. Miess
8	Nose Positioned Camera Mount	Jun 6/06	Joseph C. Miess
9	Searchlight	Jun 6/06	Joseph C. Miess
10	EFIS	Feb 14/08	Joseph C. Miess

APPROVED FOR THE MANAGER  
 CHICAGO AIRCRAFT CERTIFICATION OFFICE  
 CENTRAL REGION  
 FEDERAL AVIATION ADMINISTRATION

**EASA LOG OF SUPPLEMENTS**

Sup. No.	Description	Date	EASA Approved	FAA Approval on Behalf of EASA
1	Cargo Hook	Sep 28/03	*	N/A
2	Snow Shoes	Sep 28/03	*	N/A
3	External Fuel Filter	Sep 28/03	*	N/A
4	Baggage Box Extension	Sep 28/03	*	N/A
5	Camera Door	Sep 28/03	*	N/A
6	Emergency Floats	May 29/05	2005-4677	N/A
7	Air Conditioning	May 30/05	2005-4682	N/A
8	Nose Positioned Camera Mount	Jun 6/06	Decision 2004/04/CF	N/A
9	Searchlight	Jun 6/06	Decision 2004/04/CF	N/A
10	EFIS	NOT APPROVED		

\* Article 3, Commission Regulation (EU) 748/2012



## TABLE OF CONTENTS

<u>SECTION</u>	<u>DESCRIPTION</u>	<u>PAGE</u>
	Manual Cover	
	Log of Revisions .....	i
	Log of Supplements.....	iii
	Table of Contents .....	v
	Log of Page Effectivity.....	vii
	INTRODUCTION.....	INTRO-1
CHAPTER 1	OPERATING LIMITATIONS .....	1-1
CHAPTER 2	NORMAL PROCEDURES .....	2-1
CHAPTER 3	EMERGENCY PROCEDURES .....	3-1
CHAPTER 4	PERFORMANCE DATA .....	4-1
CHAPTER 5	OPTIONAL EQUIPMENT SUPPLEMENTS .....	5-0-1
CHAPTER 6	WEIGHT/BALANCE AND LOADING ..	6-1
CHAPTER 7	HELICOPTER AND SYSTEMS DESCRIPTION AND OPERATION.....	7-1
CHAPTER 8	HANDLING, SERVICING, AND MAINTENANCE .....	8-1
CHAPTER 9	SUPPLEMENTAL INFORMATION.....	9-1
CHAPTER 10	ABBREVIATED CHECKLIST.....	10-1

**INTENTIONALLY LEFT BLANK**

**LIST OF EFFECTIVE PAGES**

<u>PAGE</u>	<u>DATE</u>	<u>PAGE</u>	<u>DATE</u>
i	May 2/19	1-14	Apr 10/02
ii	May 2/19	1-15	Apr 10/02
iii	Feb 1/08	1-16	Apr 10/02
iv	May 2/19	1-16.1	Jul 12/10
v	Apr 16/10	1-16.2	May 2/19
vi	Apr 16/10	1-17	Jun 30/04
vii	May 2/19	1-18	Jun 30/04
viii	May 2/19	1-19	Jun 30/04
ix	May 2/19	1-20	Jun 30/04
x	May 2/19	1-21	Jun 30/04
xi	May 2/19	1-22	Jun 30/04
xii	May 2/19	1-23	Jul 3/12
xiii	May 2/19	1-24	Jul 3/12
xiv	Jul 3/12	1-25	Jul 3/12
INTRO-1	Feb 9/01	1-26	Jul 16/15
INTRO-2	Feb 9/01	1-27	Feb 9/01
INTRO-3	May 2/19	1-28	Feb 9/01
INTRO-4	May 2/19	1-29	Feb 9/01
INTRO-5	May 2/19	1-30	Feb 9/01
INTRO-6	Feb 9/01	1-31	Feb 9/01
INTRO-7	Apr 10/02	1-32	Feb 9/01
INTRO-8	Apr 10/02	1-33	Nov 21/12
INTRO-9	Apr 10/02	1-34	Nov 21/12
INTRO-10	Apr 10/02	2-1	May 2/19
1-1	May 2/19	2-2	Apr 16/10
1-2	May 2/19	2-3	Apr 16/10
1-3	May 2/19	2-4	Jul 3/12
1-4	May 2/19	2-5	Jul 3/12
1-5	Feb 9/01	2-6	Jul 3/12
1-6	Apr 16/10	2-7	Jul 3/12
1-7	Apr 16/10	2-8	Jul 3/12
1-8	Jul 16/15	2-9	Apr 16/10
1-9	Jul 3/12	2-10	Jul 3/12
1-10	Apr 16/10	2-11	Jul 3/12
1-11	Apr 28/16	2-12	Jul 3/12
1-12	Apr 16/10	2-13	Apr 16/10
1-13	Apr 28/16	2-14	Apr 28/16

**LIST OF EFFECTIVE PAGES**

<u>PAGE</u>	<u>DATE</u>	<u>PAGE</u>	<u>DATE</u>
2-15	Apr 28/16	3-9	Feb 9/01
2-16	May 2/19	3-10	Feb 9/01
2-17	May 2/19	3-11	Feb 9/01
2-18	Apr 16/10	3-12	Feb 9/01
2-19	Jun 14/11	3-13	Feb 2/04
2-20	Apr 16/10	3-14	Feb 2/04
2-21	Apr 16/10	3-15	Feb 9/01
2-22	Apr 16/10	3-16	Feb 9/01
2-23	Apr 16/10	3-17	Feb 9/01
2-24	Apr 16/10	3-18	Feb 9/01
2-25	Apr 16/10	3-19	Feb 2/04
2-26	Apr 16/10	3-20	Feb 2/04
2-27	Apr 16/10	3-21	Apr 10/02
2-28	Apr 16/10	3-22	Apr 10/02
2-29	Apr 16/10	3-23	Apr 16/10
2-30	Apr 28/16	3-24	Sep 5/03
2-31	Apr 16/10	3-25	Apr 16/10
2-32	Apr 16/10	3-26	Feb 9/01
2-33	Apr 16/10	3-27	Feb 9/01
2-34	Apr 16/10	3-28	Feb 9/01
2-35	Apr 16/10	3-29	Feb 9/01
2-36	Apr 16/10	3-30	Feb 9/01
2-37	Apr 16/10	3-31	Apr 10/02
2-38	Apr 16/10	3-32	Apr 10/02
2-39	Apr 16/10	3-33	Apr 10/02
2-40	Apr 16/10	3-34	Apr 10/02
2-41	Apr 16/10	3-35	Apr 10/02
2-42	Apr 16/10	3-36	Apr 10/02
2-43	Apr 16/10	3-37	Mar 17/05
2-44	Apr 16/10	3-38	Jul 16/15
3-1	Feb 9/01	3-39	Jul 12/10
3-2	Jul 12/10	3-40	Jul 12/10
3-3	Nov 21/12	3-41	Jul 12/10
3-4	Feb 9/01	3-42	Nov 21/12
3-5	Feb 9/01	3-43	Nov 21/12
3-6	Feb 9/01	3-44	Nov 21/12
3-7	Feb 9/01	4-1	May 22/06
3-8	Feb 9/01	4-2	May 22/06

**LIST OF EFFECTIVE PAGES**

<u>PAGE</u>	<u>DATE</u>	<u>PAGE</u>	<u>DATE</u>
4-3	May 22/06	4-40	Feb 2/04
4-4	May 22/06	4-41	Feb 9/01
4-5	Feb 9/01	4-42	Feb 9/01
4-6	Feb 9/01	4-43	Feb 9/01
4-7	Feb 9/01	4-44	Feb 9/01
4-8	Feb 9/01	4-45	Feb 9/01
4-9	Feb 9/01	4-46	Feb 9/01
4-10	Feb 9/01	5-0-1	Feb 1/08
4-11	May 22/06	5-0-2	Feb 1/08
4-12	May 22/06	5-1-1	Feb 9/01
4-13	May 22/06	5-1-2	Feb 9/01
4-14	May 22/06	5-1-3	Apr 16/10
4-15	Feb 9/01	5-1-4	Feb 2/04
4-16	Feb 9/01	5-1-5	Feb 9/01
4-17	Apr 11/07	5-1-6	Feb 9/01
4-18	Apr 11/07	5-1-7	Jul 16/15
4-19	Feb 2/04	5-1-8	Jul 16/15
4-20	Feb 2/04	5-1-9	Feb 9/01
4-21	Apr 11/07	5-1-10	Feb 9/01
4-22	Apr 11/07	5-1-11	Feb 9/01
4-23	Feb 9/01	5-1-12	Feb 9/01
4-24	Feb 9/01	5-1-13	Feb 2/04
4-25	Feb 9/01	5-1-14	Feb 2/04
4-26	Feb 9/01	5-2-1	Sep 5/07
4-27	Nov 21/12	5-2-2	Sep 5/07
4-28	Feb 9/01	5-2-3	Sep 5/07
4-29	Feb 9/01	5-2-4	Sep 5/07
4-30	Feb 9/01	5-2-5	Feb 9/01
4-31	Feb 9/01	5-2-6	Feb 9/01
4-32	Feb 9/01	5-2-7	Feb 9/01
4-33	Feb 9/01	5-2-8	Feb 9/01
4-34	Feb 9/01	5-2-9	Feb 2/04
4-35	Feb 9/01	5-2-10	Feb 2/04
4-36	Feb 9/01	5-3-1	Feb 9/01
4-37	Feb 9/01	5-3-2	Feb 9/01
4-38	Feb 9/01	5-3-3	Feb 9/01
4-39	Feb 2/04	5-3-4	Feb 9/01

**LIST OF EFFECTIVE PAGES**

<u>PAGE</u>	<u>DATE</u>	<u>PAGE</u>	<u>DATE</u>
5-3-5	Feb 9/01	5-7-3	Apr 16/10
5-3-6	Feb 9/01	5-7-4	Apr 16/10
5-3-7	Feb 9/01	5-7-5	Apr 16/10
5-3-8	Feb 9/01	5-7-6	Apr 16/10
5-3-9	Feb 9/01	5-7-7	Apr 16/10
5-3-10	Feb 9/01	5-7-8	Apr 16/10
5-4-1	Feb 9/01	5-7-9	Jun 30/04
5-4-2	Feb 9/01	5-7-10	Jun 30/04
5-4-3	Feb 2/04	5-7-11	Apr 16/10
5-4-4	Jul 16/15	5-7-12	Apr 16/10
5-4-5	Feb 9/01	5-7-13	Apr 16/10
5-4-6	Feb 9/01	5-7-14	Apr 16/10
5-4-7	Feb 9/01	5-7-15	Apr 16/10
5-4-8	Feb 9/01	5-7-16	Apr 16/10
5-4-9	Feb 9/01	5-7-17	Apr 16/10
5-4-10	Feb 9/01	5-7-18	Apr 16/10
5-5-1	Sep 5/07	5-8-1	May 22/06
5-5-2	Sep 5/07	5-8-2	May 22/06
5-5-3	Sep 5/07	5-8-3	May 22/06
5-5-4	Sep 5/07	5-8-4	Apr 16/10
5-5-5	Feb 2/04	5-8-5	May 22/06
5-5-6	Feb 2/04	5-8-6	May 22/06
5-5-7	Feb 9/01	5-8-7	May 22/06
5-5-8	Feb 9/01	5-8-8	May 22/06
5-5-9	Feb 9/01	5-8-9	May 22/06
5-5-10	Feb 9/01	5-8-10	May 22/06
5-6-1	May 22/06	5-9-1	May 22/06
5-6-2	May 22/06	5-9-2	May 2/19
5-6-3	Apr 28/16	5-9-3	May 2/19
5-6-4	May 22/06	5-9-4	May 22/06
5-6-5	May 22/06	5-9-5	May 22/06
5-6-6	May 22/06	5-9-6	May 22/06
5-6-7	May 22/06	5-9-7	May 22/06
5-6-8	May 22/06	5-9-8	May 22/06
5-6-9	May 22/06	5-9-9	May 22/06
5-6-10	Jul 16/15	5-9-10	May 22/06
5-7-1	Apr 16/10	5-9-11	May 22/06
5-7-2	Jun 30/04	5-9-12	May 2/19

**LIST OF EFFECTIVE PAGES**

<u>PAGE</u>	<u>DATE</u>	<u>PAGE</u>	<u>DATE</u>
5-9-13	May 2/19	6-9	Nov 21/12
5-9-14	May 22/06	6-10	Feb 9/01
5-10-1	Feb 1/08	6-11	Feb 9/01
5-10-2	Jan 25/11	6-12	Feb 9/01
5-10-3	Apr 22/08	6-13	Nov 21/12
5-10-4	Apr 22/08	6-14	Apr 28/16
5-10-5	Feb 1/08	6-15	Nov 21/12
5-10-6	Feb 1/08	6-16	Feb 9/01
5-10-7	Feb 1/08	6-17	Feb 9/01
5-10-8	Feb 1/08	6-18	Aug 29/11
5-10-9	Feb 1/08	6-19	Feb 9/01
5-10-10	Apr 22/08	6-20	Jun 14/11
5-10-11	Jan 25/11	6-21	Feb 9/01
5-10-12	Feb 1/08	6-22	Feb 9/01
5-10-13	Feb 1/08	6-23	Feb 9/01
5-10-14	Feb 1/08	6-24	Feb 9/01
5-10-15	Feb 1/08	6-25	Apr 10/02
5-10-16	Feb 1/08	6-26	Jun 14/11
5-10-17	Apr 22/08	7-1	Nov 21/12
5-10-18	Feb 1/08	7-2	Apr 16/10
5-10-19	Feb 1/08	7-3	Jul 12/10
5-10-20	Feb 1/08	7-4	May 2/19
5-10-21	Apr 22/08	7-4.1	Apr 10/02
5-10-22	Apr 16/10	7-4.2	Apr 10/02
5-10-23	Feb 1/08	7-5	Feb 9/01
5-10-24	Feb 1/08	7-6	Feb 9/01
5-10-25	Feb 1/08	7-7	Feb 9/01
5-10-26	Jan 25/11	7-8	Feb 9/01
5-10-27	Jan 25/11	7-9	Apr 16/10
5-10-28	Jan 25/11	7-10	Apr 16/10
6-1	Jul 3/12	7-11	Sep 8/04
6-2	Feb 9/01	7-12	Jan 25/11
6-3	Feb 9/01	7-12.1	Jan 25/11
6-4	Feb 9/01	7-12.2	Jan 25/11
6-5	Apr 10/02	7-12.3	Jan 25/11
6-6	Jul 3/12	7-12.4	Jan 25/11
6-7	Jul 3/12	7-13	Jul 12/10
6-8	Jul 3/12	7-14	Jul 12/10

### LIST OF EFFECTIVE PAGES

<u>PAGE</u>	<u>DATE</u>	<u>PAGE</u>	<u>DATE</u>
7-15	Jul 12/10	7-48	Jun 14/11
7-15.1	Jul 3/12	7-49	Jun 14/11
7-15.2	Jul 12/10	7-50	Jun 14/11
7-16	Nov 21/12	7-51	Apr 16/10
7-17	Nov 21/12	7-52	Apr 16/10
7-18	Feb 9/01	7-53	Apr 16/10
7-19	Apr 11/07	7-54	Feb 9/01
7-20	Apr 11/07	7-55	Apr 10/02
7-21	Feb 9/01	7-56	Nov 21/12
7-22	Jan 25/11	7-57	Jul 3/12
7-23	Jan 25/11	7-58	Jul 12/10
7-24	Jan 25/11	7-59	Jul 12/10
7-25	Jan 25/11	7-60	May 2/19
7-26	Jan 25/11	7-61	May 2/19
7-27	Jan 25/11	7-62	Apr 10/02
7-28	Jan 25/11	7-62.1	Jan 25/11
7-28.1	Jan 25/11	7-62.2	Jul 12/10
7-28.2	Jan 25/11	7-63	Jul 12/10
7-29	Nov 21/12	7-64	Jul 12/10
7-30	Feb 9/01	7-65	Jun 14/11
7-31	Apr 10/02	7-66	Feb 9/01
7-32	Jul 16/15	7-67	Aug 29/11
7-33	Jan 25/11	7-68	Apr 28/16
7-34	Jan 25/11	7-69	Jan 25/11
7-35	Jan 25/11	7-70	Jan 25/11
7-36	Feb 9/01	7-70.1	Jan 25/11
7-37	Jul 3/12	7-70.2	Jan 25/11
7-38	Jul 3/12	7-71	Jan 25/11
7-39	Feb 9/01	7-72	Jan 25/11
7-40	Feb 9/01	7-73	Jul 16/15
7-41	Feb 9/01	7-74	Jul 12/10
7-42	Feb 9/01	7-75	Jul 12/10
7-43	Apr 10/02	7-76	May 2/19
7-44	Apr 10/02	8-1	Aug 11/06
7-45	Feb 9/01	8-2	Aug 11/06
7-46	Feb 9/01	8-3	Sep 5/03
7-47	Feb 9/01	8-4	Jul 16/15



**LIST OF EFFECTIVE PAGES**

<u>PAGE</u>	<u>DATE</u>	<u>PAGE</u>	<u>DATE</u>
8-5	Aug 10/10	10-4	Apr 16/10
8-6	Aug 10/10	10-5	Apr 16/10
8-7	Feb 9/01	10-6	Apr 16/10
8-8	Feb 9/01	10-7	Apr 28/16
8-9	Feb 9/01	10-8	Apr 16/10
8-10	Feb 9/01	10-9	Apr 16/10
8-11	Aug 11/06	10-10	Apr 16/10
8-12	Jun 14/11	10-11	Apr 16/10
8-12.1	Jun 14/11	10-12	Apr 16/10
8-12.2	Jun 14/11	10-13	Apr 28/16
8-13	Jul 3/12	10-14	Apr 28/16
8-14	Aug 11/06	10-15	Apr 16/10
8-15	Jun 14/11	10-16	Apr 16/10
8-16	Aug 11/06	10-17	Apr 28/16
8-17	Feb 9/01	10-18	Apr 28/16
8-18	Feb 9/01	10-19	Apr 16/10
8-19	Jul 3/12	10-20	Apr 16/10
8-20	Aug 10/10	10-21	Apr 16/10
8-21	Jul 16/15	10-22	Apr 16/10
8-22	Jul 16/15	10-23	Apr 16/10
8-23	Jul 3/12	10-24	Apr 16/10
8-24	Jul 3/12	10-25	Apr 16/10
8-25	Apr 16/10	10-26	Apr 16/10
8-26	Apr 16/10	10-27	Apr 16/10
8-27	Feb 9/01	10-28	Apr 16/10
8-28	Feb 9/01	10-29	Apr 16/10
9-1	Apr 16/10	10-30	Apr 16/10
9-2	Sep 8/04	10-31	Apr 16/10
9-3	Feb 9/01	10-32	Apr 28/16
9-4	Feb 9/01	10-33	Apr 28/16
9-5	Feb 9/01	10-34	Apr 28/16
9-6	Apr 16/10	10-35	Apr 28/16
9-7	Apr 16/10	10-36	Apr 28/16
9-8	Sep 8/04		
10-1	Apr 16/10		
10-2	Apr 16/10		
10-3	Apr 16/10		

**INTENTIONALLY LEFT BLANK**

## INTRODUCTION

### TABLE OF CONTENTS

<u>PARAGRAPH</u>	<u>DESCRIPTION</u>	<u>PAGE</u>
	Table of Contents.....	INTRO-1
INTRO-1	General .....	INTRO-3
INTRO-2	Warnings, Cautions, and Notes .....	INTRO-3
INTRO-3	Descriptions .....	INTRO-4
INTRO-4	Table of Contents.....	INTRO-4
INTRO-5	Reporting of Errors .....	INTRO-4
INTRO-6	Explanation of Change Symbols .....	INTRO-4
INTRO-7	Use of Words Shall, Should, and May .....	INTRO-5
INTRO-8	Definitions of Abbreviations .....	INTRO-6

### LIST OF TABLES

<u>TABLE NO.</u>	<u>DESCRIPTION</u>	<u>PAGE</u>
INTRO-1	List of Abbreviations .....	INTRO-6

**INTENTIONALLY LEFT BLANK**

## INTRODUCTION

### INTRO-1. General

This manual contains the operating instructions, procedures and limitations for the Enstrom 480B helicopter. The manual is divided into two basic parts, the FAA approved Rotorcraft Flight Manual (RFM) and Supplemental Data Provided by The Enstrom Helicopter Corporation (Enstrom). Chapters 1, 2, 3, 4, and 5 make up the FAA approved RFM. It is required by Federal Regulations that this manual be carried in the helicopter at all times.

Chapter 5, *Optional Equipment Supplements*, contains the optional equipment supplements incorporated into this basic RFM. Refer to the Enstrom Helicopter Corporation web site and the Technical Support page for a listing of other approved Enstrom 480B Optional Equipment Supplements not contained in this basic RFM. The pilot is responsible for determining if other additional optional equipment supplements are to be carried in the helicopter.

### INTRO-2. Warnings, Cautions, and Notes

Warnings, Cautions, and Notes emphasize important and critical instructions and are used for the following conditions:

#### WARNING

**An operating procedure, practice, etc. which, if not correctly followed, could result in personal injury or loss of life.**

#### CAUTION

**An operating procedure, practice, etc. which, if not strictly observed, could result in damage to or destruction of equipment.**

## NOTE

**An operating procedure, practice, etc., which is essential and requires additional information.**

### INTRO-3. Description

This manual contains the best operating instructions and procedures for the 480B helicopter under most circumstances. The observance of limitations, performance and weight and balance data provided is mandatory. The observance of procedures is mandatory except when modification is required because of multiple emergencies, adverse weather, terrain, etc. Your flying experience is recognized, and therefore, basic flight principles are not included. **THIS MANUAL SHALL BE CARRIED IN THE HELICOPTER AT ALL TIMES.**

### INTRO-4. Table of Contents

The table of contents lists every titled paragraph, figure, and table contained in this manual.

### INTRO-5. Reporting of Errors

Every effort is made to keep this publication current and error free. However, we cannot correct an error unless we know of its existence. You are encouraged to report errors, omissions, and recommendations for improving this publication by contacting The Enstrom Helicopter Corporation.

### INTRO-6. Explanation of Change Symbols

Except as noted below, changes to the text and tables, including new material on added pages, are indicated by a vertical line in the margin. The vertical line will extend close to the entire area of the material affected. Symbols show current changes only. Change symbols are not utilized to indicate changes in the following:

1. Indexes, figures, and tabular data where the change cannot be readily identified.
2. Blank space resulting from the deletion of text, illustration, or a table.
3. Correction of minor errors, such as spelling, punctuation, relocation of material, etc. unless such correction changes the meaning of the material.

### **INTRO-7. Use of Words, Shall, Should, and May**

Within this technical manual, the word "shall" is used to indicate a mandatory requirement. The word "should" is used to indicate a nonmandatory but preferred method of accomplishment. The word "may" is used to indicate an acceptable method of accomplishment.

## **INTRO-8. Definitions of Abbreviations**

Table INTRO-1 provides definitions for abbreviations used in this manual. The same abbreviation applies for either singular or plural applications.

**TABLE INTRO-1. LIST OF ABBREVIATIONS**

<u>ABBREVIATION</u>	<u>DEFINITION</u>
ABS	Absolute
AGL	Above Ground Level
AH	Amp Hour
ALT	Altitude
B.L.	Butt Line
C	Celsius
CAS	Calibrated Airspeed
CG	Center of Gravity
C.L.	Center Line
CONF	Configuration
CONT	Continuous
END	Endurance
F	Fahrenheit
FAA	Federal Aviation Administration
FLT	Flight
FPM	Feet per Minute
F.S.	Fuselage Station
FT	Foot
FT/MIN	Feet per Minute
FWD	Forward



**TABLE INTRO-1. LIST OF ABBREVIATIONS**

GAL	Gallon
GAL/HR	Gallon per Hour
GW	Gross Weight
HR	Hour
Hz	Hertz (Cycles per Second)
IAS	Indicated Airspeed
IGE	In Ground Effect
IN	Inch
IN HG	Inches of Mercury
ISA	International Standard Atmosphere
KCAS	Knots Calibrated Airspeed
KIAS	Knots Indicated Airspeed
KTAS	Knots True Airspeed
km	Kilometer
KT	Knot
l	Liter
LB	Pound
LB/HR	Pound per Hour
MAX	Maximum
MB	Millibars
MIN	Minimum
MIN	Minute

**TABLE INTRO-1. LIST OF ABBREVIATIONS**

N <sub>1</sub>	Gas Producer Turbine Speed
N <sub>2</sub>	Power Turbine Speed
NICAD	Nickel Cadmium
NO.	Number
NM	Nautical Mile
OAT	Outside Air Temperature
OGE	Out of Ground Effect
PRESS	Pressure
PSI	Pounds per Square Inch
R/C	Rate of Climb
R/D	Rate of Decent
REV.	Revision
RFM	Rotorcraft Flight Manual
RPM	Revolutions per Minute
SHP	Shaft Horsepower
SPEC	Specification
STA	Station
SQ FT	Square Feet
SUP.	Supplement
TAS	True Airspeed
TEMP	Temperature
TOT	Turbine Outlet Temperature
TRQ	Torque

**TABLE INTRO-1. LIST OF ABBREVIATIONS**

V <sub>D</sub>	Maximum Design Dive Speed
VDC	Volts, Direct Current
V <sub>H</sub>	Maximum Level Flight Airspeed at Maximum Continuous Power
V <sub>NE</sub>	Velocity Never Exceed  (Airspeed Limitation)
V <sub>Y</sub>	Best Rate of Climb Airspeed
WT	Weight
XMSN	Transmission

**INTENTIONALLY LEFT BLANK**

## CHAPTER 1. OPERATING LIMITATIONS

### TABLE OF CONTENTS

<u>SECTION</u>	<u>DESCRIPTION</u>	<u>PAGE</u>
	Table of Contents .....	1-1
Section I	Introduction .....	1-3
Paragraph 1-1	Purpose.....	1-3
1-2	General .....	1-3
1-3	Operational Limits.....	1-3
Section II	General .....	1-3
Paragraph 1-4	Kinds of Operation .....	1-3
1-5	Minimum Crew Requirements ....	1-4
Section III	Helicopter & System Limits .....	1-5
Paragraph 1-6	Instrument Markings .....	1-5
1-7	Rotor Limitations .....	1-5
1-8	Transmission Limits.....	1-5
1-9	Engine Limits .....	1-6
1-10	Starter Limits .....	1-9
Section IV	Operation Limits .....	1-17
Paragraph 1-11	Airspeed Limits .....	1-17
1-12	Altitude Limits .....	1-18
1-13	Load Limits .....	1-23
1-14	Maneuvers .....	1-23
1-15	Environmental .....	1-24
1-16	Restrictions in Use of Anti-torque Pedals.....	1-25
1-17	Placards .....	1-25

### LIST OF FIGURES

<u>FIGURE NO.</u>	<u>DESCRIPTION</u>	<u>PAGE</u>
1-1	Instrument Markings.....	1-11
1-2	Maximum Allowable Torque and $N_2$ ..	1-16.2
1-3	Airspeed Operating Limits .....	1-19
1-4	$V_{NE}$ Envelopes.....	1-22
1-5	$V_{NE}$ Placards .....	1-27

**LIST OF TABLES**

<u>TABLE NO.</u>	<u>DESCRIPTION</u>	<u>PAGE</u>
1-1	Kinds of Operation Equipment List.....	1-4

## CHAPTER 1

### OPERATING LIMITATIONS

#### SECTION I. INTRODUCTION

##### 1-1. Purpose

1. This chapter includes operating limitations and restrictions that must be observed during ground and flight operations.

##### 1-2. General

1. The operating limitations set forth in this chapter are the direct results of design analysis and flight tests. Compliance with these limits will allow the pilot to derive maximum utility from the helicopter.

##### 1-3. Operational Limits

1. Anytime an operational limit is exceeded an appropriate entry shall be made in the aircraft log book. The entry shall state what limit or limits were exceeded, and the range and time beyond the limits including any additional data that would aid maintenance personnel in the proper disposition of the entry and inspection of the aircraft.

#### SECTION II. GENERAL

##### 1-4. Kinds of Operation

1. This aircraft is certified in normal category for day and night VFR operation in non-icing conditions when the appropriate instruments and equipment required by the airworthiness and/or operating rules are installed and approved and are in operable condition. Table 1-1 lists the equipment that is required to be operable for typical VFR operations. Additional equipment may be required by operational regulations. The pilot is responsible for determining if there are additional requirements.

**Table 1-1. Kinds of Operation Equipment List**

<b>System and/or Component</b>	<b>VFR DAY</b>	<b>VFR NIGHT</b>	<b>NOTES</b>
Airspeed Indicator	1	1	
Altimeter	1	1	
AMP/Volt	1	1	
Clock	0	0	
Compass	1	1	
Dual Tachometer	1	1	
Engine Oil Temperature/ Pressure	1	1	
Fuel Quantity Indicator	1	1	
N1 Indicator	1	1	
OAT	1	1	
Torque Indicator	1	1	
TOT Indicator	1	1	
Transmission Oil Temperature	1	1	
Anticollision Lights	0	0	
Instrument Lights	0	1	
Landing Light	0	1	
Position Lights	0	1	
Switch and Circuit Breaker Panel Lighting	0	1	

**1-5. Minimum Crew Requirements**

1. The minimum crew is one pilot. Solo from left seat only.



## **SECTION III. HELICOPTER AND SYSTEM LIMITS**

### **1-6. Instrument Markings**

1. The operating limitations for both the helicopter and systems are listed below and presented in Figure 1-1.

2. Operating Limitations and Ranges. Operating limitations and ranges are illustrated by the colored markings which appear on the dial faces of engine, flight and utility system instruments. Red markings on the dial faces of these instruments indicate the maximum and/or minimum limits. The green markings on the instruments indicate the safe normal range of operation. The yellow markings on the instruments indicate the range when special attention should be given to the operation covered by the instrument. Operation is permissible in the yellow range, but should be avoided.

### **1-7. Rotor Limitations**

1. Normal Operating Limits. The maximum and minimum rotor RPM limits shown in Figure 1-1 apply during continuous powered flight and autorotation for all aircraft weight configurations.

2. Minimum Transient Rotor Speed. The minimum allowable transient rotor speed following engine failure or sudden power reduction for practice forced landing is 300 RPM. This is a transient limit and positive corrective action (lowering the collective) must be taken immediately by the pilot to regain at least 334 RPM (minimum power off rotor RPM).

### **1-8. Transmission Limits**

1. The main transmission is subject to the torque limitations shown in Figure 1-2. Operating time above the maximum continuous limit of 65 PSI in the range of 65-72 PSI is limited to 5 minutes duration.

**WARNING**

**Aircraft operating limits are based on the transmission torque limits and not the engine torque limits.**

**1-9. Engine Limits**

## 1. Power limits:

- a. Takeoff Power. Takeoff rated power is the maximum power permitted and is limited to a period of 5 minutes. Takeoff power is defined by a combination of torque and  $N_2$  speed. It may be limited by Turbine Outlet Temperature (TOT) on hot days or at high altitude. The limits for takeoff for this helicopter are:

Torque	72 PSI
Turbine Outlet Temperature	810°C
$N_2$ Speed	103%

- b. Normal Rated Power (Continuous). Normal rated power is the maximum continuous power limit for this helicopter and is also defined by a combination of torque and  $N_2$  speed. It may, under circumstances of high altitude or hot ambient conditions, be limited by TOT. The normal rated (continuous) power limits for this helicopter are:

Torque	65 PSI
Turbine Outlet Temperature	737°C
$N_2$ Speed	103%

2. Engine Overspeed. The engine overspeed limits are as follows:

Gas Producer Turbine (N <sub>1</sub> )	105% Continuous
	106% for 15 seconds
Power Turbine (N <sub>2</sub> )	See Figure 1-2

### 3. Engine Starting

- a. Start Cycle Time. The minimum time between ground starting attempts is 30 seconds.
- b. Minimum Oil Temperature. The minimum oil temperature for starting is -54°C for MIL-PRF-7808 series oil and -40°C for MIL-PRF-23699 series oil.
- c. Oil Pressure During Start. A positive indication of oil pressure must be obtained when 59% N<sub>1</sub> is reached and must stabilize at least at 50 PSI at idle.

**CAUTION**

**Following starts in very cold ambient conditions, the oil pressure may exceed 130 PSI immediately after start up to a maximum of 150 PSI. The engine must not be accelerated from idle until the oil pressure has returned within the specified limits.**

4. Ambient Temperature and Altitude Limits. The ambient temperature limits for the engine are -54°C from sea level to 20,000 feet pressure altitude, and up to +54°C from sea level to 6,000 feet then decreasing linearly to 27°C at 20,000 feet pressure altitude using primary fuels.

**NOTE**

**The maximum operating altitude for the 480B is 13,000 feet density altitude (Refer to paragraph 1-12).**

5. Fuel Operational Limits
  - a. Primary Fuel is defined as fuel conforming to MIL-DTL-5624 (formerly MIL-T-5624) Grade JP-4 or JP-5, MIL-DTL-83133 (formerly MIL-G-83133) Grade JP-8, ASTM D1655 Jet A or A1, and ASTM D6615 Jet B. Refer to Table 8-4 for additional primary fuels.

#### NOTE

**At ambient temperatures below 4°C (40°F), all fuels used shall contain Anti-Icing Additive conforming to MIL-DTL-85470. The Anti-Icing Additive shall be added to all commercial fuel, not already containing an anti-icing additive, during refueling operations. Refueling operations shall be accomplished in accordance with accepted commercial procedures. Commercial product PRIST® HI-FLASH™ conforms to MIL-DTL-85470.**

---

#### CAUTION

---

**Avoid using anti-icing additives packaged in aerosol cans. Failure to exactly follow the additive mixing procedures during refueling can result in incorrect additive concentrations, fuel system contamination, and possible engine stoppage.**

- b. Emergency Fuel is defined as ASTM D910 (formerly MIL-G-5572) AVGAS grade 80/87 or grade 100/130 with a maximum of 2.0 ml/gal lead content. ASTM D910 AVGAS fuel containing tricresylphosphate (TCP) shall not be used. Use of emergency fuel shall be limited to six (6) hours total engine operating time between overhaul (TBO). Entry in the aircraft log book is required. Practice autorotations are prohibited using emergency fuel.

6. Lubrication System Limits

- a. Oil Specification. Approved oils for the engine are MIL-PRF-23699C or subsequent (Formerly MIL-L-23699C) or MIL-PRF-7808G or subsequent (Formerly MIL-L-7808).
- b. Oil Pressure Limits

94.2% N <sub>1</sub> and above	115-130 PSI
78.5%- 94.2% N <sub>1</sub>	90-130 PSI
Below 78.5% N <sub>1</sub>	50-130 PSI

**1-10. Starter Limits**

- 1. Starter limits are as follows:
  - a. If no TOT within the first 20 seconds:

EXTERNAL POWER	BATTERY POWER
25 seconds ON	40 seconds ON
30 seconds OFF	60 seconds OFF
25 seconds ON	40 seconds ON
30 seconds OFF	60 seconds OFF
25 seconds ON	40 seconds ON
30 minutes OFF	30 minutes OFF

- b. If rise in TOT occurs during the first 20 seconds:

EXTERNAL OR BATTERY POWER
1 minute ON
1 minute OFF
1 minute ON
1 minute OFF
1 minute ON
30 minutes OFF

**NOTE**

**Below 40°F (4°C) the starter engage time limits do not apply.**

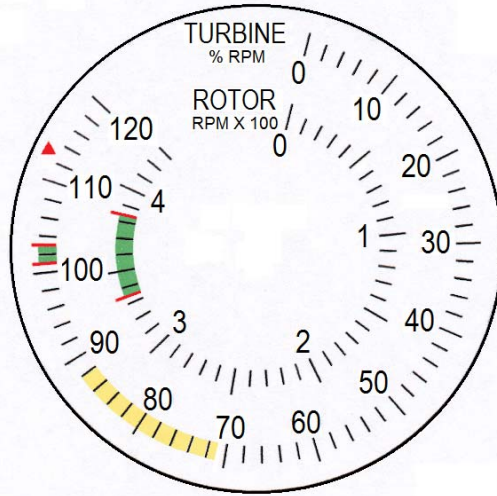

**DUAL (ROTOR AND POWER TURBINE) TACHOMETER**

<b>ROTOR</b>		
385 RPM	Red Radial	Maximum Power OFF
334-385 RPM	Green Arc	Continuous Operation (Including Autorotation)
334 RPM	Red Radial	Minimum Power OFF

<b>POWER TURBINE (N<sub>2</sub>)</b>		
113% RPM	Red Arrowhead	15 Second Maximum Transient N <sub>2</sub> Varies Linearly from 113% in Autorotation per Figure 1-2.
103% RPM	Red Radial	Maximum N <sub>2</sub> Continuous
101-103% RPM	Green Arc	Normal Operating Range
101% RPM	Red Radial	Minimum N <sub>2</sub> Continuous
71-88 % RPM	Yellow Arc	Speed avoid range. Move through range as expeditiously as possible.

Sheet 1 of 7

Figure 1-1. Instrument Markings

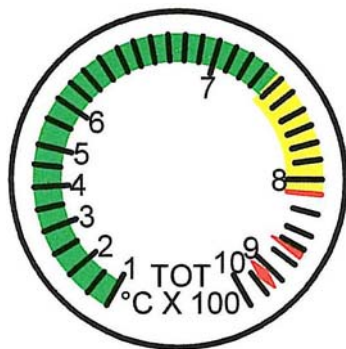

<b>TURBINE OUTLET TEMPERATURE</b>		
927°C	Red Diamond	Maximum Temp. 1 Second - Starting Only
810-927°C		10 seconds during start only
843°C	Red Arrowhead	Maximum Transient Limit
810-843°C		Maximum 6 seconds during transient power only
810°C	Red Radial	Maximum takeoff (5 minute limit)
737-810°C	Yellow Arc	Maximum 5 minutes (takeoff power)
0 - 737°C	Green Arc	Continuous operation

Sheet 2 of 7

Figure 1-1. Instrument Markings





Early Indicator

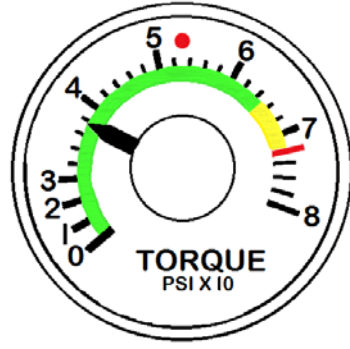

Current Indicator

TORQUEMETER		
72 PSI	Red Radial	Maximum for Takeoff
65-72 PSI	Yellow Arc	5 Minute Limit
0-65 PSI	Green Arc	Continuous Operation



AIRSPEED INDICATOR		
125 kts	Red Radial	Maximum Power On VNE
85 kts	Red Cross-Hatched Radial	Maximum Autorotation VNE

Figure 1-1. Instrument Markings



Current Indicator

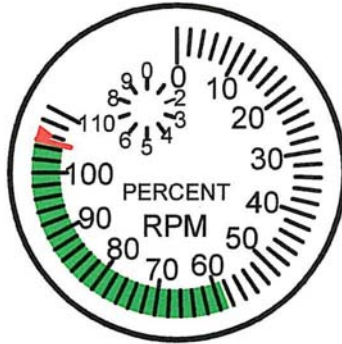

Early Indicator

GAS PRODUCER TACHOMETER (N <sub>1</sub> )		
106% RPM	Red Arrowhead	Maximum
105%-106% RPM		Maximum for 15 seconds
105% RPM	Red Radial	Maximum Continuous
59%-105% RPM	Green Arc	Normal Operation

Figure 1-1. Instrument Markings

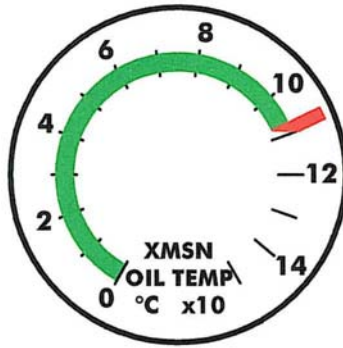

Current Indicator

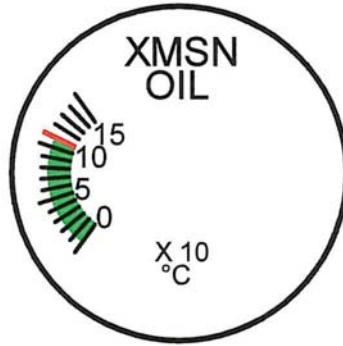

Early Indicator

MAIN TRANSMISSION OIL TEMPERATURE		
107°C	Red Radial	Maximum
0-107°C	Green Arc	Normal Operation

Figure 1-1. Instrument Markings

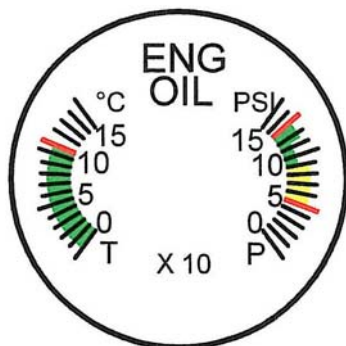

### ENGINE OIL TEMPERATURE AND PRESSURE

TEMPERATURE		
107°C	Red Radial	Maximum Oil Temperature
0-107°C	Green Arc	Normal Operation

PRESSURE		
130 PSI	Red Radial	Maximum Oil Pressure
115-130 PSI	Green Arc	Normal Operation for All N <sub>1</sub> Speeds
90-115 PSI	Narrow Green Arc	Oil Pressure Range for N <sub>1</sub> Speeds Below 94.2%
50-90 PSI	Yellow Arc	Oil Pressure Range for N <sub>1</sub> Speeds Below 78.5%
50 PSI	Red Radial	Minimum Oil Pressure

Sheet 6 of 7

Figure 1-1. Instrument Markings

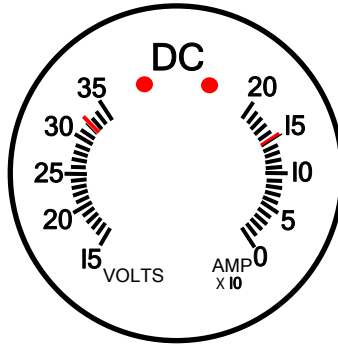

150 Amp System Indicator

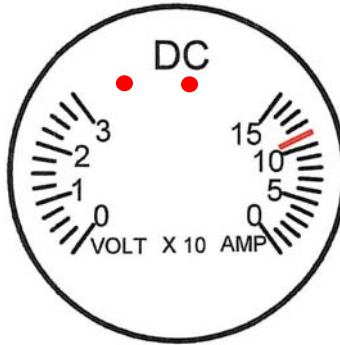

110 Amp System Indicator

**DUAL VOLT/AMMETER**

<b>VOLT</b>		
32 Vdc	Red Radial	Maximum Voltage (S/N 5134 and sub.)
<b>AMMETER</b>		
150 Amps	Red Radial	Maximum Current (S/N 5134 and sub.)
110 Amps		Maximum Current (Prior to S/N 5134)

Sheet 7 of 7

Figure 1-1. Instrument Markings

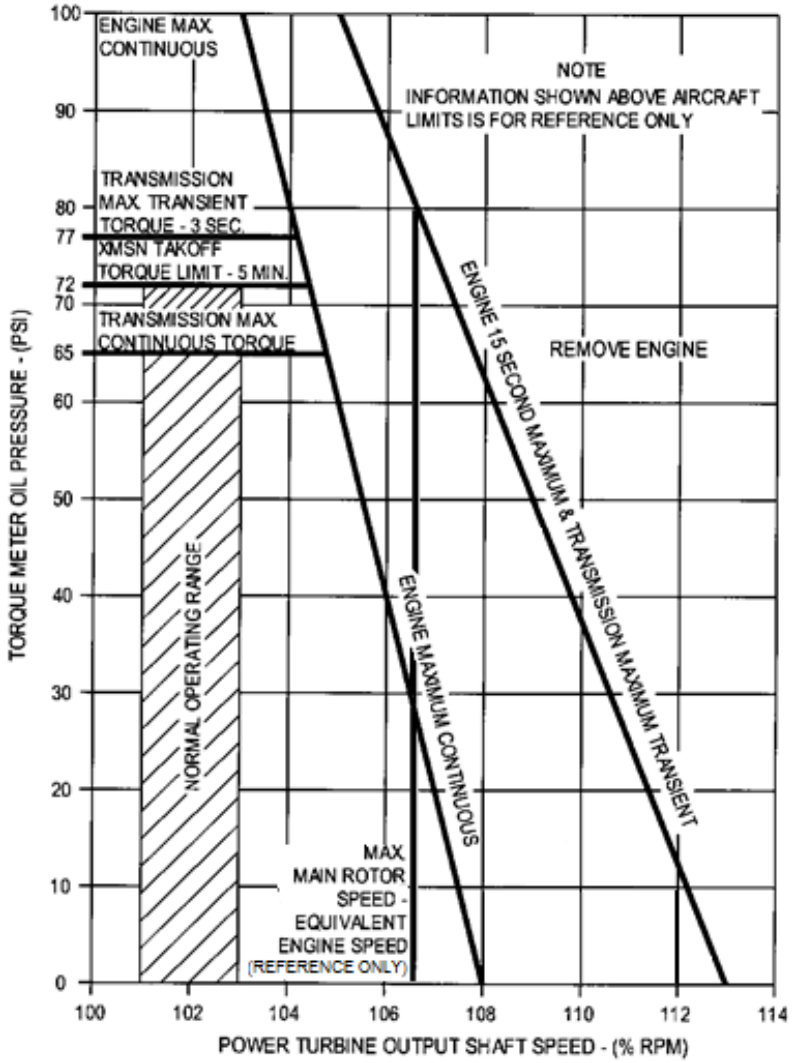

Figure 1-2. Maximum Allowable Torque and N<sub>2</sub>

## SECTION IV. OPERATIONAL LIMITS

### 1-11. Airspeed Limits

1.  $V_{NE}$ . The airspeed limits are a function of pressure altitude, temperature, takeoff gross weight, and takeoff center of gravity. Figure 1-3 presents the velocity never exceed ( $V_{NE}$ ) of the aircraft. The maximum sea level  $V_{NE}$  of the aircraft at 3000 pounds gross weight is 124 KIAS with doors on or off.

2. Autorotation  $V_{NE}$ . The autorotation  $V_{NE}$  limit is 85 knots or the power on  $V_{NE}$  limit, which ever is less. Refer to Figure 1-3.

3. Sideward and Rearward. The helicopter is limited to 35 knots sideward and rearward flight. There is no wind azimuth, relative to the nose, that is critical for directional control of the aircraft. Sideward and rearward flight has been demonstrated at 8,000 feet density altitude.

4. Flight With Doors Removed. There are no restrictions for flight with the doors removed, however, all loose objects and equipment within the cabin must be properly secured and the cushions for the unoccupied seat(s) must be removed or properly strapped down using the lap belts and shoulder harnesses. The rear bulkhead soundproofing must be checked for security and condition prior to flight and firm attachment to the airframe assured.

### NOTE

**When operating the aircraft with one or both doors removed, a loud buffeting may be encountered at speeds above 65 knots. Although this noise may be loud enough to be annoying, it does not affect the safety of flight of the aircraft.**

**1-12. Altitude Limits**

1. The maximum approved operating altitude of the helicopter is 13,000 feet density altitude at gross weights up to 2,850 pounds (1,295.4 kg). From gross weights between 2,851 to 3,000 pounds (1,295.9 to 1,363.6 kg), the maximum approved operating altitude is 10,000 feet density altitude.



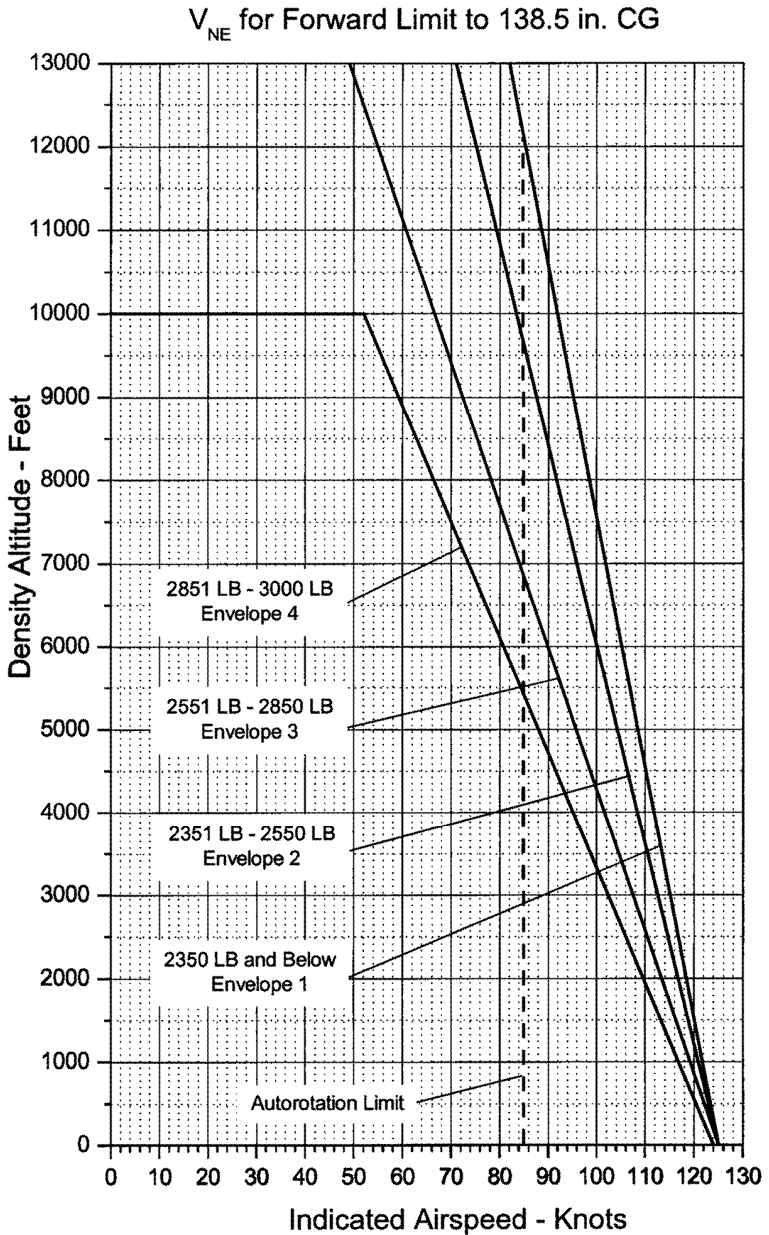

Sheet 1 of 3

Figure 1-3. Airspeed Operating Limits

$V_{NE}$  for 138.51 to 141.5\* in. CG  
\*To Aft Limit for Envelope 8

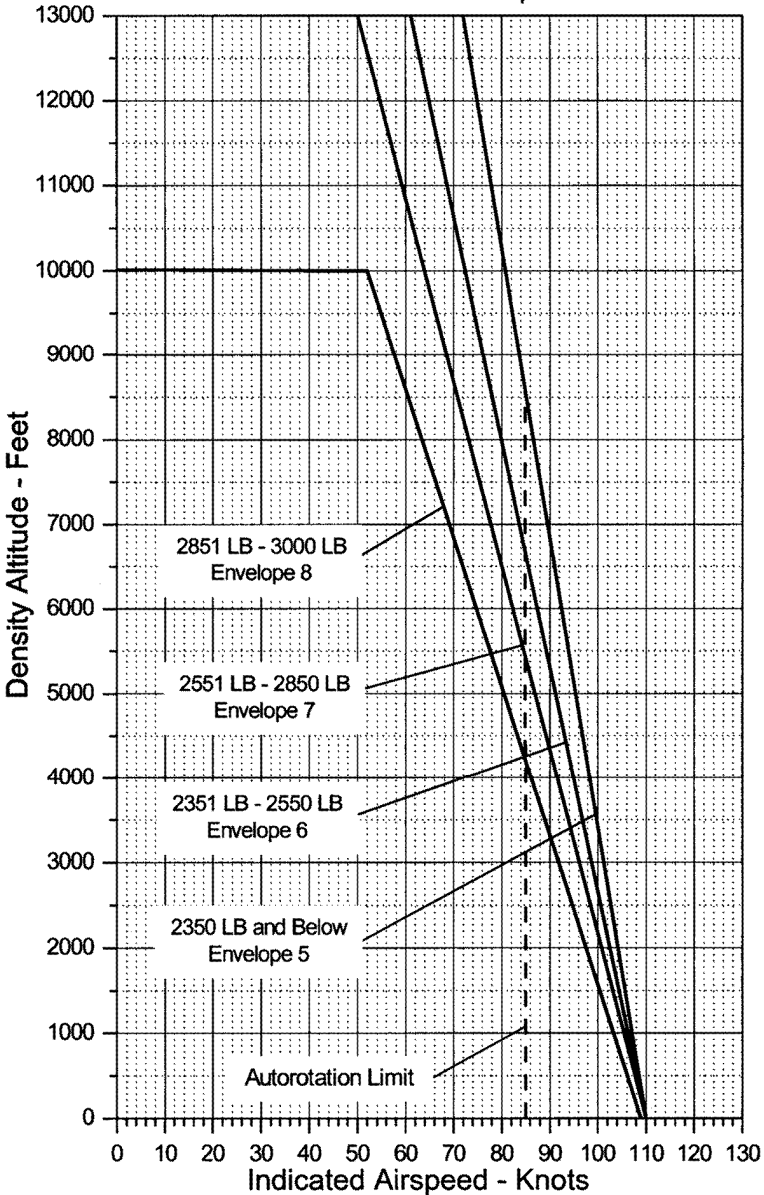
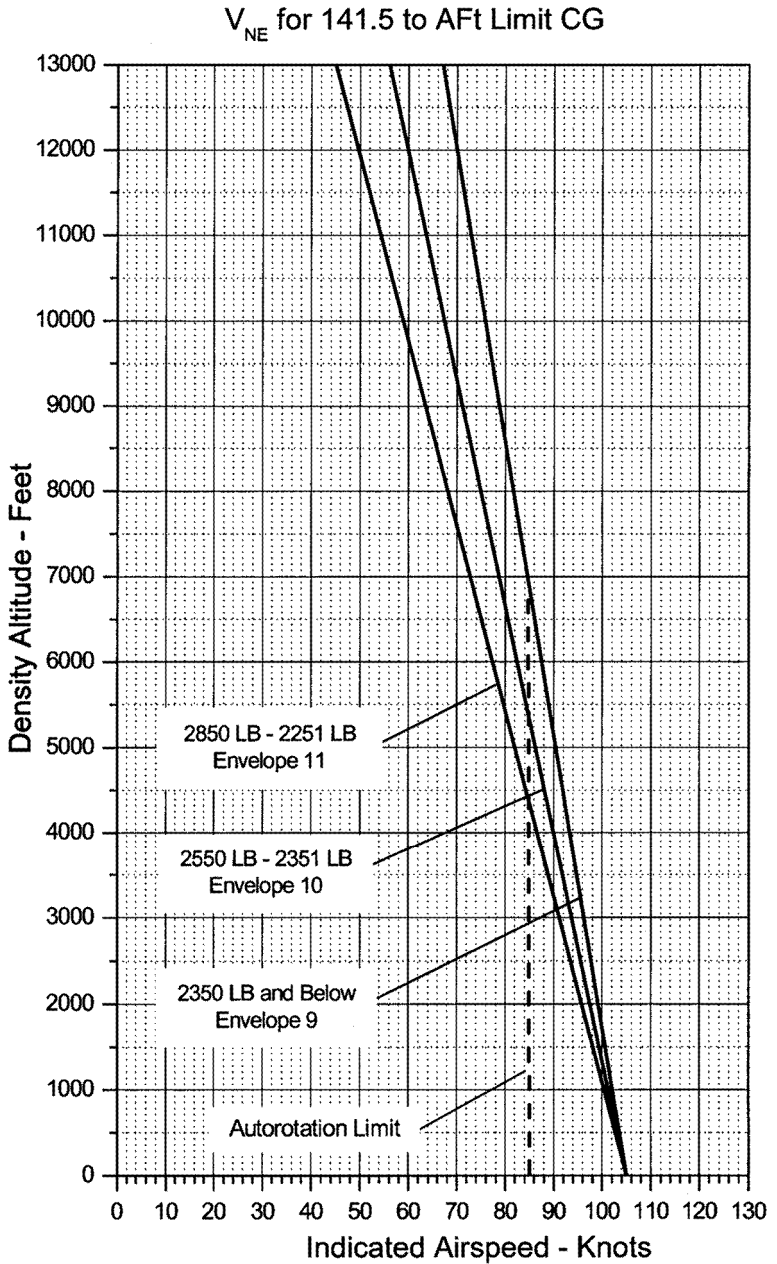

Figure 1-3. Airspeed Operating Limits



Sheet 3 of 3

Figure 1-3. Airspeed Operating Limits

### Gross Weight vs C.G. for $V_{NE}$ Envelopes

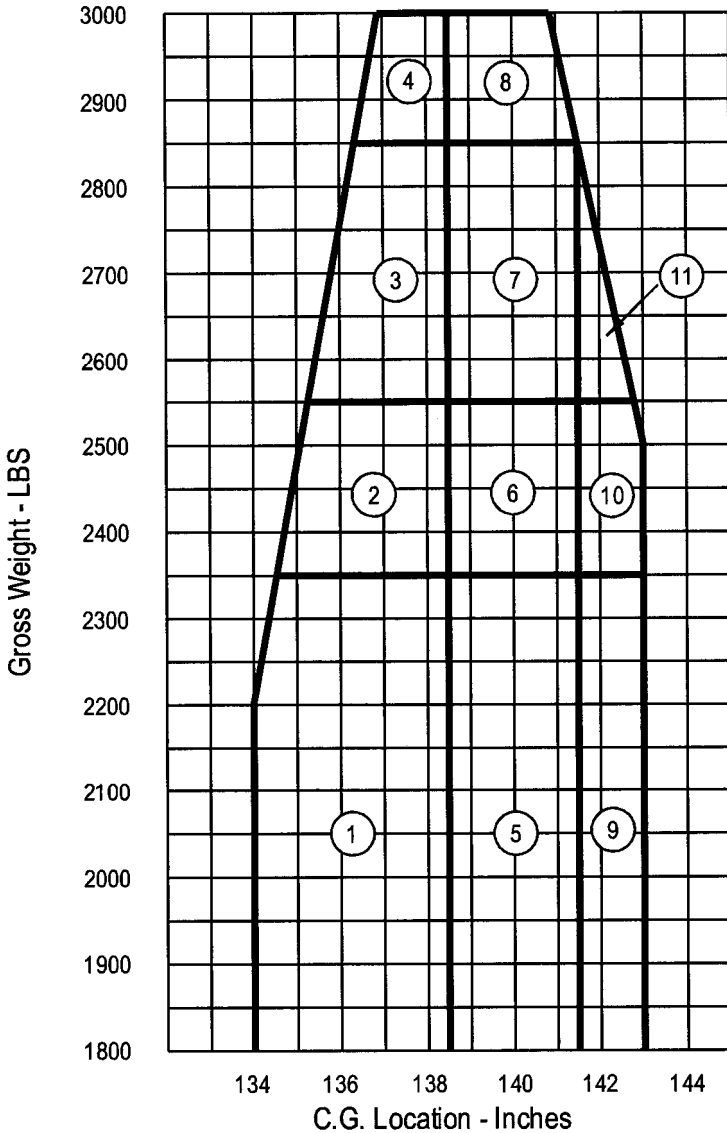

⊙ "X"  $V_{NE}$  Envelope Designator

Figure 1-4.  $V_{NE}$  Envelopes

### 1-13. Load Limits

1. Weight. The maximum gross weight of the helicopter is 3,000 pounds when operating at density altitudes from sea level up to 10,000 feet. The maximum gross weight of the helicopter is 2,850 pounds when operating at density altitudes from 10,000 feet to 13,000 feet.

2. Center of Gravity. The Center of Gravity Limitations Chart is presented in Chapter 6. Weight/Balance and Loading. The limitations are as follows:

- a. AFT CG is 140.9 in. at 3,000 pounds gross weight expanding linearly to 143.0 in. for all weights at and below 2,500 pounds.
- b. FWD CG is 134.0 in. for all weights up to 2,200 pounds and decreasing linearly to 136.9 in. at 3,000 pounds gross weight.

3. Lateral Center of Gravity. The lateral center of gravity is expressed in terms of lateral offset moment. The lateral offset moment limits are  $\pm 7500$  in-lbs.

4. The maximum allowable weight in the baggage box is 150 pounds.

5. The maximum allowable weight on the optional baggage shelf behind the pilot's seat is 50 pounds.

### 1-14. Maneuvers

1. Aerobatics. Aerobic maneuvers, (over 90 degrees in pitch or roll), are prohibited.

---

#### CAUTION

---

**The engine is approved for operation at 90 degrees pitch up and down and zero (0) g for 10 seconds only. Dwelling at these conditions longer than 10 seconds can damage the engine.**

## 1-15. Environmental

1. Ambient Temperature. The maximum operational temperature is 106°F (41°C) at sea level to 59°F (15°C) at 13,000 ft. The minimum operational ambient temperature is -25°F (-32°C).

### NOTE

**For aircraft serial number 5114 and subsequent, the maximum ambient temperature limit is 122°F (50°C) at sea level to 75°F (24°C) at 13,000 ft if the aircraft is equipped with Engine Access Panels, P/N's 4220150-3/-4. For aircraft serial numbers 5087 through 5113, the maximum ambient temperature limit is 122°F (50°C) at sea level to 75°F (24°C) at 13,000 ft if the aircraft is equipped with the Increased Cooling Kit, P/N 4230031.**

2. All de-ice and anti-ice systems, including the scavenge air for the particle separators and engine anti-ice, must be turned on when flying in the presence of visible moisture at outside temperatures of 40°F (4°C) or below and always during flight at night when the outside air temperature is 40°F (4°C) or below.

3. Falling or Blowing Snow. Flight in falling and blowing snow is authorized provided the following conditions are met:

- a. Particle Separator scavenge air is ON continuously.
- b. Engine Anti-Ice is ON continuously.
- c. Prior to initial takeoff and each subsequent takeoff, the helicopter air and oil cooler inlets are inspected for possible accumulations of snow, slush, or ice and all accumulations are removed from the exterior of the particle separator and the cabin surface adjacent to and ahead of the inlet.

- d. Prior to initial takeoff and each subsequent takeoff, the plastic particle separator ejector tubes on the aft end of the upper plenum are inspected for obstructions and snow and all such obstructions removed.

---

**CAUTION**

---

**Restrict hover operations in heavy snow conditions (1/2 mile/.8 km visibility or less) to 10 minutes or less per flight.**

### **1-16. Restrictions in Use of Anti-torque Pedals**

1. Avoid rapid pedal reversals (hard kicks) both on the ground and in flight.

### **1-17. Placards**

1. Placards that are to be placed in view of the pilot are:

**THIS HELICOPTER MUST BE OPERATED IN COMPLIANCE WITH THE OPERATING LIMITATIONS SPECIFIED IN THE FAA APPROVED ROTORCRAFT FLIGHT MANUAL**

(and)

**THIS HELICOPTER IS APPROVED FOR OPERATIONS UNDER DAY AND NIGHT VFR-NON-ICING CONDITIONS ONLY**

2. Beneath the fuel filler port on the left side of the aircraft:

**CAP. 90 U.S. GAL**  
**JP-4/JET-A**  
**USE MIL-DTL-5624 / ASTM D1655**  
**AT TEMPERATURES BELOW 4°C (40°F)**  
**FUEL MUST CONTAIN MIL-DTL-85470**  
**FUEL ADDITIVE**  
**(SEE RFM TABLE 8-4 FOR APPROVED ALTERNATE FUELS)**

3.  $V_{NE}$  Placards: (See Figure 1-5 for the  $V_{NE}$  Placards. The placards are located overhead above the center of the forward wind screen or on top of the instrument panel).

4. Placards located inside the baggage compartment door:

**MAX ALLOWABLE CARGO 150 LBS**

(and)

**OBSERVE C.G. AND GROSS WEIGHT LIMITATIONS**

5. Placard on baggage shelf behind pilot's seat:

**MAX. LOADING – 50 LBS.**

(and)

**BAGGAGE MUST BE SECURED PRIOR  
TO TAKEOFF AND LANDING**



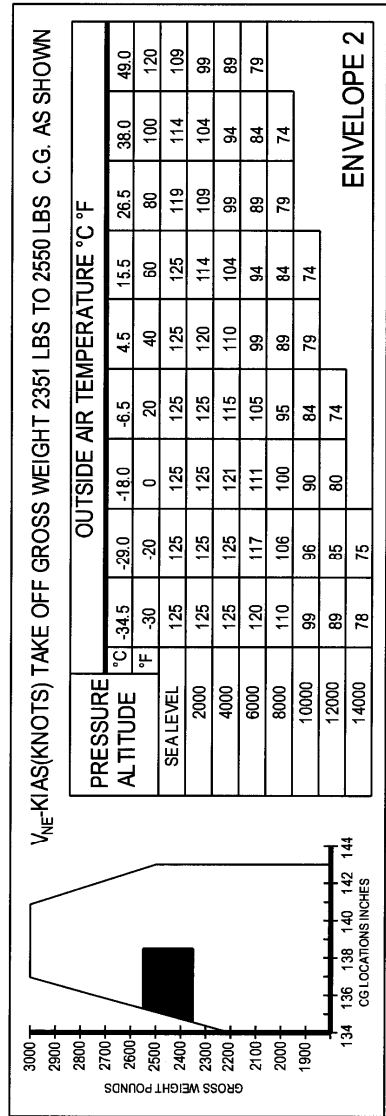
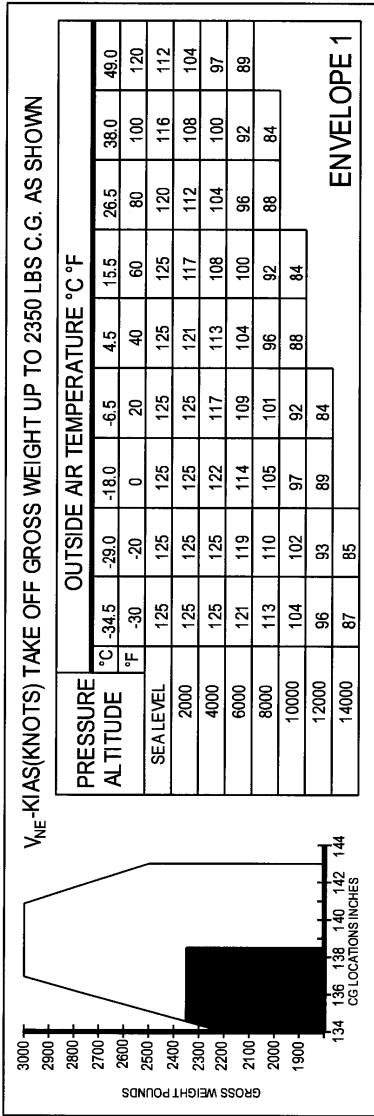

Figure 1-5.  $V_{NE}$  Placards

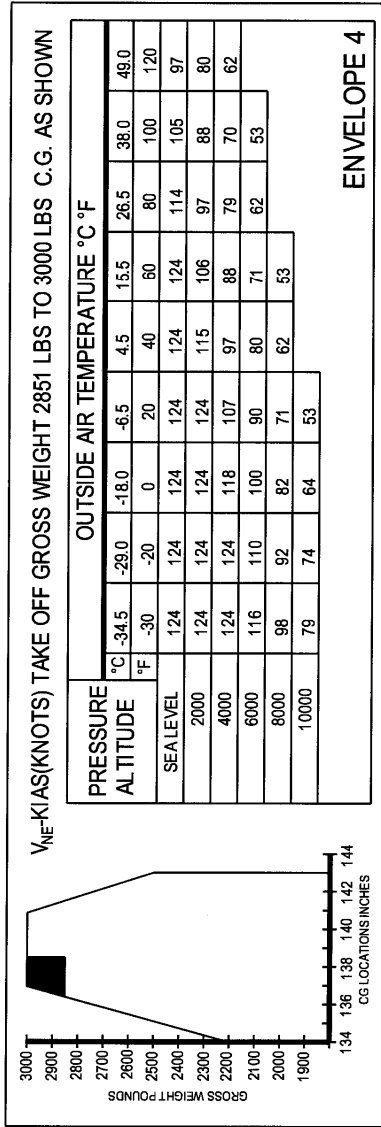
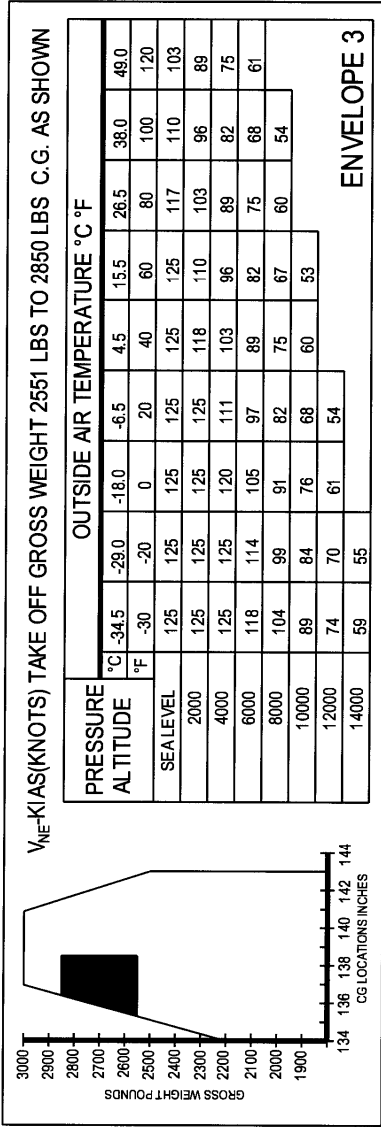

Figure 1-5. V<sub>NE</sub> Placards

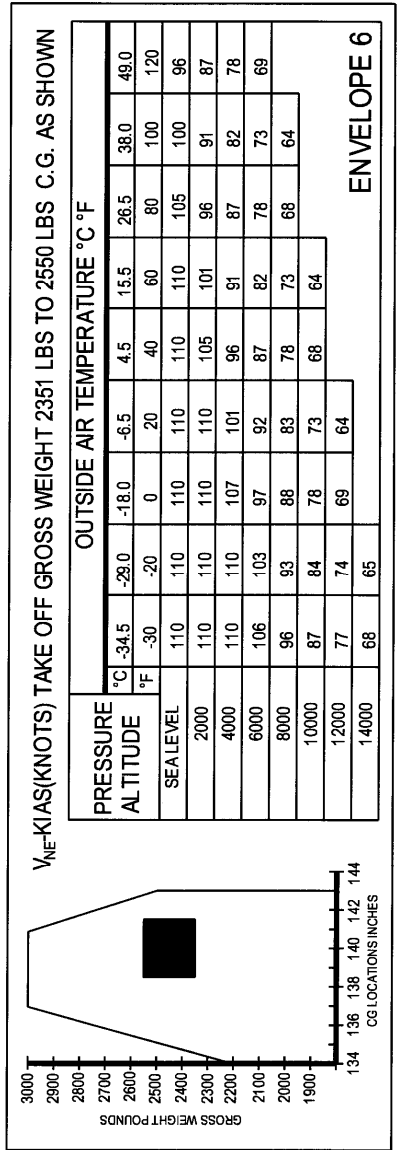
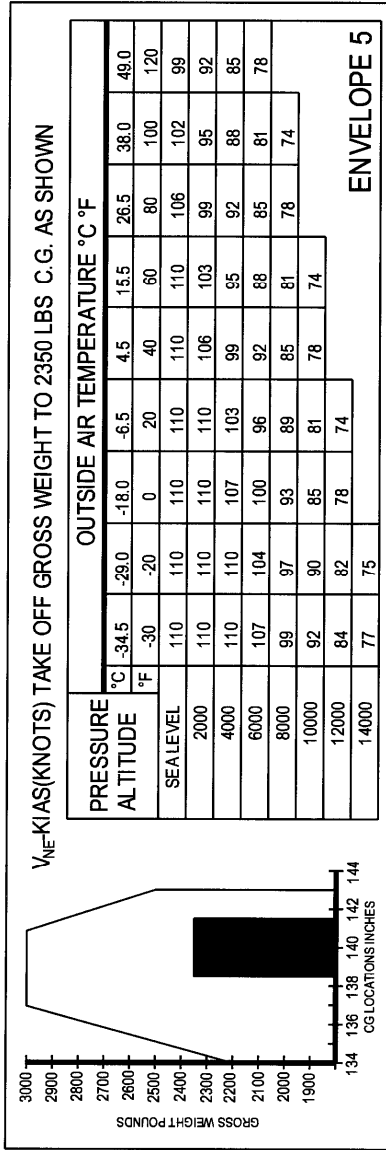

Figure 1-5. V<sub>NE</sub> Placards

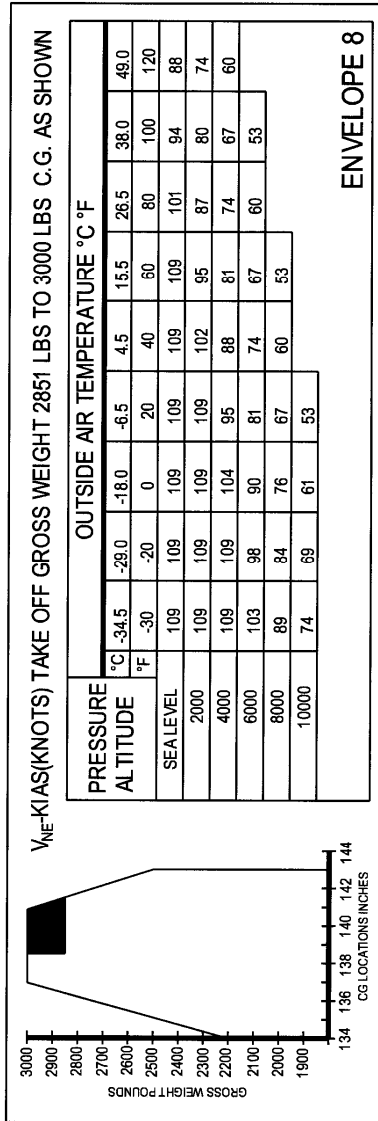
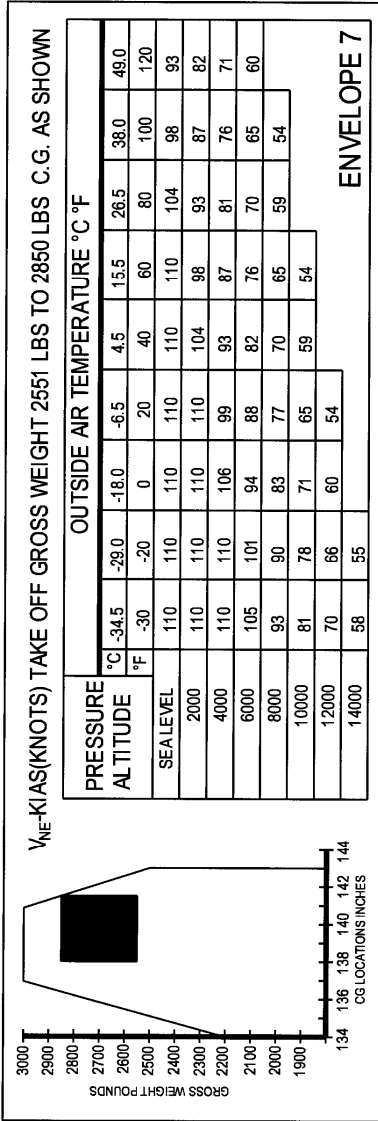
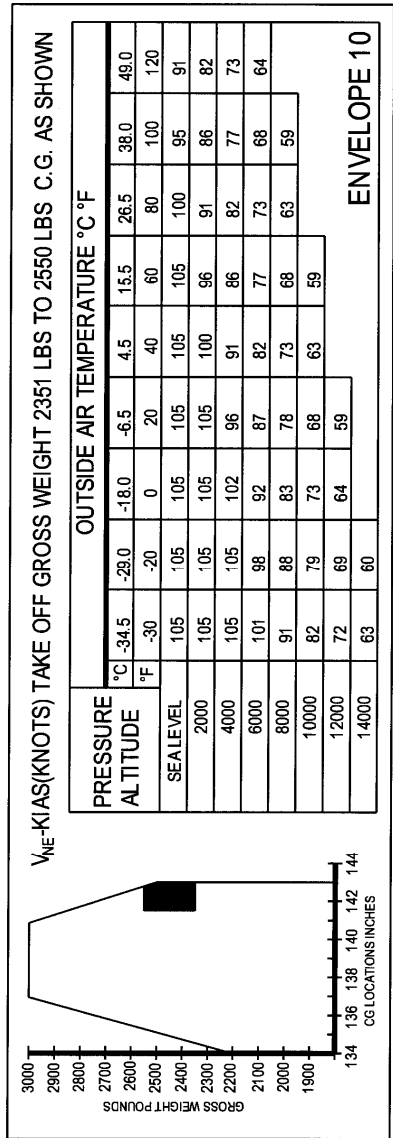
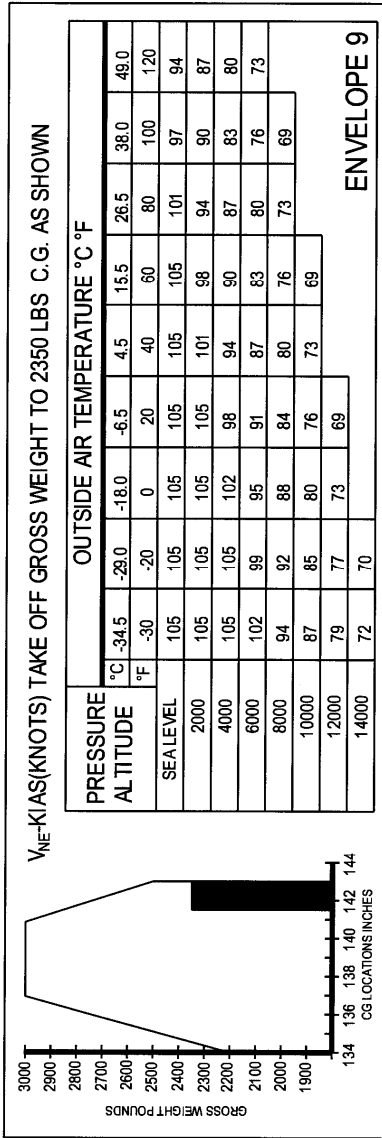
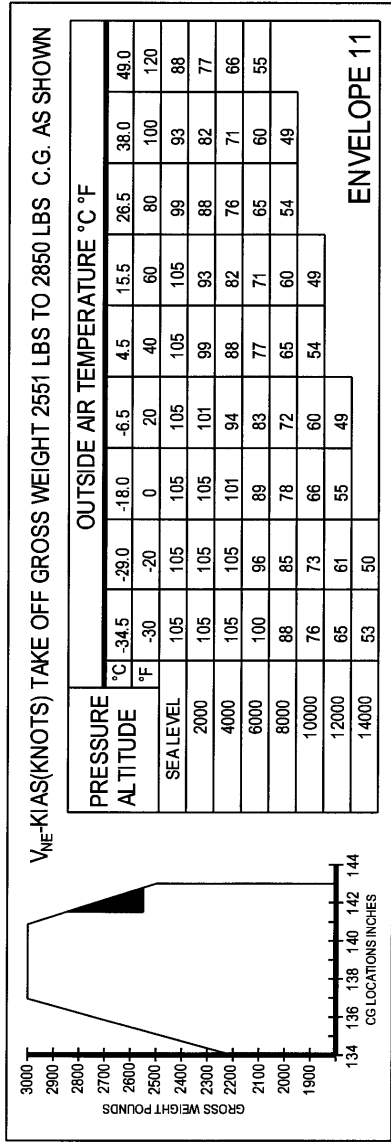

Figure 1-5.  $V_{NE}$  Placards



Sheet 5 of 6

Figure 1-5.  $V_{NE}$  Placards



Sheet 6 of 6

Figure 1-5. V<sub>NE</sub> Placards

6. Placards to be placed near the door handle:
  - a. Placard located on left cabin door:



- b. Placard located on right cabin door:



7. If optional alternate static air source switch is installed:

- a. Placard located on instrument panel next to alternate static air source switch:

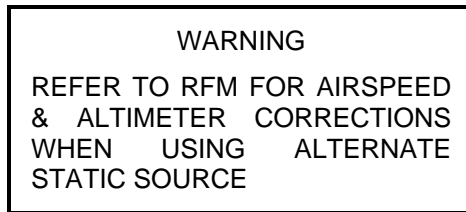

- b. Placard located in view of the pilot:

ALTERNATE STATIC SOURCE ALTIMETER CORRECTION		
INDICATED AIRSPEED (KNOTS)	ADD TO ALTIMETER READING	
	WINDOWS CLOSED (FEET)	WINDOWS OPEN (FEET)
40	+5	0
50	+5	-15
60	-10	-35
70	-25	-55
80	-40	-75
90	-60	-95
100	-75	-115
110	-95	-140
120	-115	-170



**CHAPTER 2. NORMAL PROCEDURES**

**TABLE OF CONTENTS**

<u>SECTION</u>	<u>DESCRIPTION</u>	<u>PAGE</u>
	Table of Contents .....	2-1
Section I	Flight Planning.....	2-3
Paragraph 2-1	Flight Planning.....	2-3
2-2	Operating Limits .....	2-3
2-3	Weight, Balance and Loading .....	2-3
2-4	Performance .....	2-3
Section II	Operating Procedures and	
	Maneuvers .....	2-4
Paragraph 2-5	General .....	2-4
2-6	Checklist.....	2-4
2-7	Checks .....	2-4
2-8	Before Preflight Check .....	2-4
2-8.1	Preflight Check –	
	Fuel Management.....	2-5
2-9	Preflight Check – Exterior Check	2-6
2-10	Cabin Left Side .....	2-6
2-11	Aft Fuselage Left Side.....	2-7
2-12	Tailcone Left Side.....	2-9
2-13	Tailcone Right Side .....	2-9
2-14	Aft Fuselage Right Side .....	2-10
2-15	Fuselage Top Area.....	2-12
2-16	Cabin Right Side .....	2-12
2-17	Cabin Left Side .....	2-13
2-18	Before Starting Engine .....	2-13
2-19	Starting Engine .....	2-16
2-20	Engine Runup .....	2-19
2-21	Takeoff to Hover .....	2-20
2-22	Hovering Turns .....	2-20
2-23	Sideward and Rearward	
	Hovering Flight.....	2-21
2-24	Hover Taxi.....	2-21
2-25	Cyclic Trim.....	2-21
2-26	Hover Check.....	2-21
2-27	Before Takeoff .....	2-22
2-28	Normal Takeoff.....	2-23

**CHAPTER 2. NORMAL PROCEDURES****TABLE OF CONTENTS**

<u>SECTION</u>	<u>DESCRIPTION</u>	<u>PAGE</u>
2-29	Maximum Power Takeoff Profiles.....	2-24
2-30	Crosswind Takeoff.....	2-26
2-31	Climb.....	2-26
2-32	Cruise.....	2-26
2-33	Descent.....	2-26
2-34	Before Landing.....	2-26
2-35	Approach and Landing.....	2-27
2-36	Landing From A Hover.....	2-28
2-37	After Landing.....	2-28
2-38	Engine Shutdown.....	2-29
2-39	Before Leaving The Helicopter ...	2-30
2-40	Night Flight.....	2-30
Section III	Passenger Briefing .....	2-31
Paragraph 2-41	Passenger Briefing .....	2-31
Section IV	Adverse Environmental	
	Conditions .....	2-32
Paragraph 2-42	Cold Weather Operation .....	2-32
2-43	Cold Weather Inspection .....	2-32
2-44	Cold Weather Checks .....	2-34
2-45	Snow.....	2-36
2-46	Desert and Hot Weather Operations .....	2-39
2-47	Icing Conditions.....	2-40
2-48	High Altitude Operations.....	2-41
2-49	High Altitude Cold Weather Operation.....	2-42
2-50	Deceleration Check .....	2-42

**LIST OF FIGURES**

<u>FIGURE NO.</u>	<u>DESCRIPTION</u>	<u>PAGE</u>
2-1	Exterior Check .....	2-6

## CHAPTER 2

### NORMAL PROCEDURES

#### SECTION I. FLIGHT PLANNING

##### 2-1. Flight Planning

1. Flight planning begins when the flight is assigned and extends to the preflight check of the helicopter. It includes, but is not limited to, checks of operating limitations and restrictions; weight, balance and loading, performance; publications; flight plan and crew and passenger briefings. The pilot in command shall ensure compliance with the contents of this manual that are applicable to the flight.

##### 2-2. Operating Limits

1. The minimum, maximum, normal and cautionary operational ranges represent careful, aerodynamic and structural calculations, substantiated by flight test data. These limitations must be adhered to during all phases of the flight. Refer to Chapter 1, OPERATING LIMITATIONS, for detailed information.

##### 2-3. Weight, Balance and Loading

1. The helicopter must be loaded, cargo and passengers secured, and weight and balance verified in accordance with Chapter 6, WEIGHT/BALANCE AND LOADING. The weight and center-of-gravity conditions must be within the limits listed in Chapter 1.

##### 2-4. Performance

1. Refer to Chapter 4, PERFORMANCE DATA, to determine the capability of the helicopter for the entire flight. Consideration must be given to changes in performance resulting from variations in loads, temperatures, and pressure altitudes.

## SECTION II. OPERATING PROCEDURES AND MANUEVERS

### 2-5. General

1. This section deals with normal procedures, and includes all steps necessary to ensure safe and efficient operation of the helicopter. Unique feel, characteristics and reaction of the helicopter during various phases of operation and the techniques and procedures used for taxiing, takeoff, climb, etc. are described, including precautions to be observed. Your flying experience is recognized; therefore, basic flight principles are avoided.

### 2-6. Checklist

1. Normal procedures are given primarily in checklist form, and amplified as necessary in accompanying paragraph form when a detailed description of a procedure or maneuver is required.

### 2-7. Checks

1. The checklist includes items for day and night flights, with annotative indicators immediately preceding the check to which they are pertinent: (N) for night operations only; and (O) to indicate a requirement if the equipment is installed.

### 2-8. Before Preflight Check

1. Publications – Check. Check the Airworthiness Certificate, FCC License (if required), Registration; the appropriate weight and balance Form F-511-5, and the 480B Operators Manual are on board.

(O) 2. Aircraft tiedowns, covers, grounding cables – Removed and stowed.

3. BATT switch – ON.

4. Fuel quantity – Check.

5. Lights – ON then OFF after check. Check landing, strobe anti-collision, position, and interior lights for condition and operation.
6. BATT switch – OFF.
7. Right Side Flight Controls – Check secure if installed. Check properly stowed if removed and check all covers for security.
8. Co-pilot/passenger and passenger seats and restraints – Check condition and security.
9. Pedals – Adjust as required.
10. Cargo – Check loading and security.
11. First aid kit – Check condition and security.
12. Fire extinguisher – Check for charge, condition, and security.

### 2-8.1. Preflight Check – Fuel Management

- 1 Right fuel tank drain – Drain sample into jar. Verify the fuel grade, check the cleanliness, and check that fuel is free of water.

#### WARNING

**Sample the left and right fuel tank sumps before checking the low point drain.**

#### NOTE

**Aircraft should be level or slightly nose down. Rock the aircraft by moving the tail up and down to displace any water or contaminants to the low point drain. If water is found, rock the aircraft and re-sample. Check the other tank. Then check the low point drain.**

2. Left fuel tank drain - Drain sample into jar. Verify the fuel grade, check the cleanliness, and check that fuel is free of water.

3. Low point drain – Secure and drain fuel sample into jar. Verify the fuel grade, check the cleanliness, and check that the fuel is free of water.

## 2-9. Preflight Check – Exterior

### NOTE

**Refer to Figure 2-1 for the location of the area numbers specified during the exterior check.**

## 2-10. Cabin Left Side – Exterior Check (Area 1)

1. Forward landing gear – Check condition and security of fairings, tubes, skids, step, and skid shoes. Check oleo for proper inflation (para. 8-10).

(O) 2. Cabin Door – Check condition, operation, and security.

3. Static port – Check unobstructed.

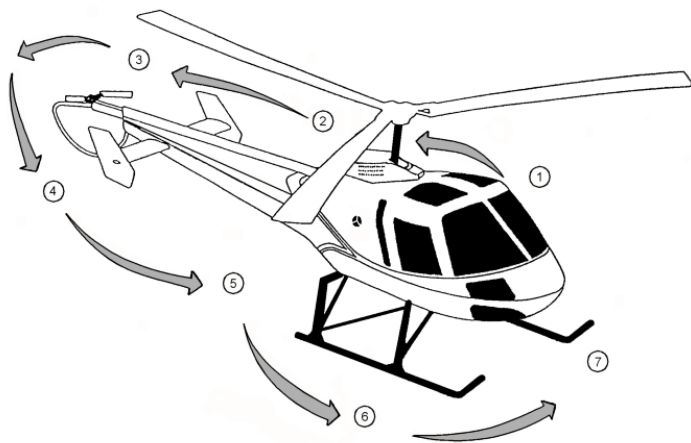

Figure 2-1. Exterior Check

## **2-11. Aft Fuselage Left Side – Exterior Check** (Area 2)

1. Fuselage – Check condition as other items are checked.
2. Engine Compartment – Check:
  - a. Fuel lines – Check for condition, security, and leaks.
  - b. Flight controls – Check for security. Check condition and security of vibration absorber and lanyard.
  - c. Engine – Check for security of all air, oil and fuel lines and evidence of leaks.
  - d. Fire detection pressure loop – Check condition and security.
  - e. Electrical Wiring – Check condition, security, and any evidence of short circuits or overheating.
  - f. Lower pulley assembly – Check condition and security. Check bearing housing sight plugs for proper oil level (para. 8-8).
  - g. Drive belt – Check condition and tension.
  - h. Tail rotor cable – Check condition, tension, and routing.
  - i. Engine fire curtain – Check condition and security.
  - j. Main rotor transmission oil filtration/cooling system – Check filter assembly and visible oil lines for condition and oil leaks. Check condition of lockwire on oil filter.

- k. Overrunning Clutch – If the overrunning clutch (ORC) cover is equipped with sight glass, check oil level in the sight glass. If the overrunning clutch (ORC) is equipped with a vented clutch oil reservoir, check oil level in the sight glass. The oil level in the ORC cover and the oil reservoir sight glasses should be the same. Service the ORC if oil does not fill the sight glass(es) (paragraph 8-8.1).
- (O) 1. External fuel filter – Check impending bypass indicator.
- (O) m. Cargo hook suspension cables – Check.
- (O) n. Cargo hook – Check condition and security.
- (O) o. Cargo hook manual release mechanism and electrical release wiring – Check.
- (O) p. Cargo hook electrical release – Check.
- (O) q. Cargo hook manual release – Check.
- r. Engine compartment door – Secure.
- 3. Lower engine compartment – Secure.
- 4. Fuel – Check quantity, cap secure.
- 5. Engine inlet and plenum – Check clean and unobstructed.
- 6. Aft landing gear – Check condition and security of fairings, tubes, step, skids, and skid shoes. Ground handling wheels removed. Check oleo for proper inflation (para. 8-10).
- 7. Oil cooler air intake – Unobstructed.
- 8. Baggage compartment – Check cargo properly loaded and secured. Check battery for leakage, proper connection, and security if located in baggage box. Close and lock door.
- (O) 9. Snowshoes – Check condition and security.



### **2-12. Tailcone Left Side – Exterior Check** (Area 3)

1. Tailcone – Check condition as other items are checked.
2. Static port – Check unobstructed.
- 1 (O) 3. Antennas – Check condition and security.
4. Tail rotor drive shaft – Check cover closed and secure.
5. Horizontal stabilizer – Check condition and security.
- 1 6. Position and strobe (if equipped) lights – Check condition and security. Check security of light shield.
7. Vertical stabilizer – Check condition and security.
8. Tail rotor – Check condition and security. Check control condition, security, and travel. Check strike tabs.

### **2-13. Tailcone Right Side – Exterior Check** (Area 4)

1. Tail Rotor Guard – Check condition and security.
2. Tail rotor gearbox – Check general condition, oil level (para. 8-7), chip detector, and continuity sensor unit.
3. Tailcone extension – Check condition and security.
4. Vibration absorber – Check condition and security.
5. Tailcone – Check condition as other items are checked.
6. Horizontal stabilizer – Check condition and security.

7. Position and strobe (if equipped) lights – Check condition and security. Check security of light shield.
8. Vertical stabilizer – Check condition and security.
- (O) 9. Antennas – Check condition and security.
10. Static port – Check unobstructed.

#### **2-14. Aft Fuselage Right Side – Exterior Check** (Area 5)

1. Oil cooler exhaust – Check condition and unobstructed.
2. Aft landing gear – Check condition and security of fairings, tubes, step, skids, and skid shoes. Ground handling wheels removed. Check oleo for proper inflation (para. 8-10).
3. Engine exhaust and eductor – Check.
4. Lower LED anticollision light (if equipped) – Check condition and security.
5. Engine Compartment – Check:
  - a. Fuel lines – Check for condition, security, and leaks.
  - b. Flight controls – Check for security. Check condition and security of vibration absorber and lanyard.
  - c. Engine – Check for security of all air, oil and fuel lines and evidence of leaks.
  - d. Fire Detection Pressure Loop – Check condition and security.

- e. Battery, starter, relays, and associated electrical wiring – Check condition, security, and any evidence of short circuits or overheating. Make sure battery is securely connected or all battery hardware is properly stowed.
- f. Engine oil reservoir – Check condition, oil level, and cap secure. For an accurate indication, oil level should be checked within 15 minutes of engine shutdown.
- g. Oil Lines – Check for condition, security and leaks.
- h. Lower pulley restraint rods – Check condition and security.
- i. Scavenge oil filter – Check impending bypass indicator retracted. If out, log in aircraft log book. It can be reset once. If it pops a second time maintenance action is required.
- j. Tail rotor cables – Check condition, tension, and routing.
- k. Engine fire curtain – Check condition and security.
- l. Throttle position – against the minimum position stop.
- (O) m. Cargo hook suspension cables – Check.
- n. Engine compartment door – Secure.
- 6. Lower engine compartment access panels – Check security.
- 7. Main rotor transmission oil level – Check oil sight gage at least half full (para. 8-7).
- (O) 8. Snowshoes – Check condition and security.

## **2-15. Fuselage Top Area – Exterior Check** (Via steps)

1. Engine inlet and plenum – Check clean and unobstructed.
2. Upper LED anticollision light (if equipped) – Check condition and security.
3. Upper transmission area – Check ram air scoop and upper transmission area unobstructed. Check fuel cell vent lines for condition and security.
4. Main rotor system – Check condition and security. Check control linkages for condition and security. Check hydraulic dampers for condition and security. Check hub nut safeties and torque stripes. Check condition of and oil level visible in the flapping bearing oil reservoirs (para. 8-9) and for oil leakage from seals.
5. Main rotor blades – Check condition.
6. Upper pulley area – Check unobstructed. Check upper pulley fan unobstructed. Check tail rotor shafting, flex couplings, and hangar bearings for condition, security and lubrication.

## **2-16. Cabin Right Side – Exterior Check** (Area 6)

1. Static port – Check unobstructed.
- (O) 2. Cabin Door – Check condition, operation, and security.
3. Forward landing gear – Check condition and security of fairings, tubes, skids, step, and skid shoes. Check oleo for proper inflation (para. 8-10).

## **2-17. Cabin Front Area – Exterior Check** (Area 7)

1. Windshield – Check condition.
2. Pitot tube – Check unobstructed; drain hole - clean and unobstructed, cotter pin free.
3. Landing light – Check condition.
4. Fuselage underside – Check condition.
- (O) 5. Main rotor blade tape – If leading edge blade tape is installed, check condition of tape on all three blades. Check for holes or openings in the tape, air bubbles under the tape, and separation areas along the edges of the tape.

## **2-18. Before Starting Engine**

1. KEY – IN and ON.
2. Passenger briefing – Complete as required. Refer to Section III for passenger briefing.
3. Seat belts and shoulder harnesses – Fastened and tightened.
4. Inertial reel – Check operation.
5. Collective friction – OFF.
6. Flight controls – Check full travel. Center cyclic and pedals. Collective pitch unobstructed and down.
7. Collective friction – ON.
8. Throttle – Check then idle cutoff. Move to full open, then move back to the idle stop; press the idle stop release button and close to the idle cutoff position.
9. Circuit breakers – All IN.
10. Switches – All OFF.

11. Bleed air controls – OFF.
12. Systems instruments – Check for static indications and markings.
13. Flight instruments – Check indications and set as necessary.
14. Fuel valve – ON.
- (O) 15. Static air switch – STD.
16. N1-N2-NR-TOT Switch – Position to BATT and note needle movement and indication on the dual ( $N_2/N_R$ ) and gas producer ( $N_1$ ) tachometers and TOT indicator. Position to BUS and note tachometer and indicator needles return to the “park” position. Leave the N1-N2-NR-TOT switch in the BUS position.

#### NOTE

**The N1 tachometer system in early 480B's does not require aircraft power for normal or emergency operation. The emergency battery bus switch in these aircraft is labeled N2-NR-TOT.**

- (O) 17. Magnetic compass slave switch – Check in Slave position (if installed).
18. Ground power unit – Connected for start as required.
19. BATT switch – ON. Check the ENG CHIP, MAIN XMSN CHIP, and TAIL CHIP segments illuminate and remain on for approximately five seconds then go out to indicate proper continuity in all three chip detector systems.

20. Check the TORQUE, ENGINE OIL TEMP/PRESS, TRANSMISSION OIL TEMP, TOT, N<sub>1</sub>, VOLT/AMP, and FUEL QUANTITY indicator status during and after the power-on self-tests (para. 7-28.9).

(O) 21. Attitude indicator(s) – Reset by pulling the Fast Erect knob.

22. Warning lights – Check for the illumination of the ROTOR RPM and ENGINE OUT warning lights.

23. Caution panel – Test. Check that the MASTER CAUTION light, FIRE WARNING light, and all of the segments in the segmented caution panel illuminate. Release the switch and check that all lights go out except the ENGINE OUT and ROTOR RPM warning lights and DC GEN and ENG OIL PRESS caution lights.

24. Check the temperature and select correct V<sub>NE</sub>/C.G. placard.

#### NOTE

**V<sub>NE</sub> is based on a combination of pressure altitude and temperature at flight conditions and take-off gross weight and takeoff c.g. Proper determination of take-off gross weight and c.g. is required to determine the appropriate V<sub>NE</sub> envelope.**

25. Clock – Checked and set.

(O) 26. Digital Fuel Quantity – Check. Enter new fuel quantity, if required, as follows:

- a. Determine total fuel quantity on board from the fuel quantity gauge and the fueling records.
- b. Press the center toggle switch to the left (fuel remaining) position. If it agrees with the quantity on board, release the toggle switch and press "ENTER".

- c. If it reads less than the quantity on board, hold the center toggle switch to the left and simultaneously press the "ENTER" button and hold. Fuel quantity will increment.
- d. Release all switches when the digital display reads the correct amount, then press "ENTER".
- e. If it reads more than the quantity on board, hold the center switch to the right and press the "ENTER" button and hold both. The fuel quantity will decrement.
- f. Release all switches when the digital display reads the correct amount. Then press "ENTER".

27. Engine out/low rotor audio – Test by releasing the collective friction, raising the collective until both audio alarms are heard, then lowering the collective to full down and resetting the collective friction.

28. Throttle – Check closed.

29. Cyclic trim – Check by displacing the cyclic trim switch coolie hat each direction - forward, aft, left, and right - for a few seconds to determine that the motors run the proper direction and reverse properly. Then center the cyclic.

30. Anticollision lights (STRB LTS or BCN LTS) – ON.

(N) 31. POS LTS switch – ON as required.

## 2-19. Starting Engine

1. Exhaust area – clear, free of combustible foliage.
2. Rotor blades – Check clear and untied.
3. Verify TOT.



**NOTE**

**If the TOT is above 150°C, the pilot may elect to motor the engine with the throttle off until the TOT is below 150°C, prior to beginning this engine start sequence. If the engine is equipped with a start counter, this will count as a “START” but can be deducted in the engine records in accordance with the Rolls-Royce 250-C20 Series Operation and Maintenance Manual.**

4. Engine – Start as follows:
  - a. Starter switch – Press and hold. Simultaneously start the clock stop watch function to time the start to 58% N<sub>1</sub>.
  - b. TOT – Below 150°C. Motor engine as necessary to lower TOT below 150°C.
  - c. Throttle – Open quickly to the idle stop after the N<sub>1</sub> RPM passes through 12-15%. Observe recommended minimum N<sub>1</sub> speeds as noted below:

**NOTE**

**If there is a delay of more than 3 seconds between opening the throttle and light off of the engine, the operator should return the throttle to the OFF position and motor the engine for 30 seconds to clear the fuel from the burner can.**

<u>OAT (Outside Air Temp)</u>	<u>Minimum N<sub>1</sub> Speed</u>
7°C and above	15%
7°C down to -18°C	13%
-18°C and below	12%

**NOTE**

**It is not necessary to wait for the N<sub>1</sub> to peak.**

- e. Starter switch – Release at 58% N<sub>1</sub>. Note elapsed time for start. Observe the starter limitations prescribed in Chapter 1 and the average engine starting time shown in Chapter 9.
- f. Engine oil pressure – Check.
- g. Gas producer – Check 59-65% N<sub>1</sub>.
- h. N<sub>2</sub> – Check stabilized.

---

**CAUTION**

---

**If the main rotor is not moving when 30% N<sub>1</sub> is reached, abort the start and make an entry in the aircraft log book.**

- 5. Ground power unit – Disconnect (if used).

---

**CAUTION**

---

**Check that the ground power unit is disconnected prior to turning the Generator switch ON.**

6. MAIN GEN switch – ON, check DC GEN caution light out, and Volt/Ammeter indicates a load. Wait until the ammeter load decreases below the redline before turning any other electrical system on.

7. Avionics master switch – ON when the ammeter indicates less than 50 amps.

## 2-20. Engine Runup

1. Engine – Stabilize for one minute before accelerating to the flight RPM operating range.

### NOTE

**If the engine has been shut down for less than 15 minutes prior to this start, the one minute stabilization time is not necessary.**

2. Throttle – Slowly increase to full open.  $N_2$  should stabilize between 88-103%.

### NOTE

**$N_2$  should be stabilized before advancing throttle to full open. Keep torque below 30 PSI while advancing the throttle to avoid compressor surges.**

3. GOVERNOR INCR/DECR switch – Set engine RPM at  $97 \pm 1\% N_2$ .

4. Engine and transmission indications – Check.

5. ENG ANTI-ICE – Check by raising the knob up fully; check for a rise in TOT; then push the handle back in to the OFF position and check for a decrease in TOT. Set as required.

6. SCAV AIR – Check by raising the knob up fully; check for a rise in TOT; then push the handle back in to the OFF position and check for a decrease in TOT. Set as required.

(O) 7. DEFOG and HEAT – Check by turning both full ON; check for a rise in TOT; then set as required.

(O) 8. PITOT HTR (if installed) – Check by switching PITOT HTR switch to ON; check for an increase in DC Amps; then set as required.

9. Avionics – Check and set.
10. Altimeter – Set.
- (O) 11. Heading indicator(s) – Check that the heading indicator(s) align properly and the heading corresponds with the magnetic compass. Set heading indicator as required.
- (O) 12. Doors – Secured for flight.
13. Seat belts and shoulder harnesses – Secured for flight.
14. Flight controls – Check flight controls for correct response.
15. Collective friction – Set as desired just prior to takeoff.

## **2-21. Takeoff to a Hover**

1. With the cyclic control in a neutral position, increase the collective pitch with a smooth, positive pressure until the desired hovering height is reached. Apply tail rotor pedal pressures to maintain heading as collective pitch control is increased. As the helicopter leaves the ground make minor corrections with cyclic control to ensure a vertical ascent and apply pedal pressures as necessary to maintain directional control. As the desired hover height is reached, adjust the flight controls as necessary to stabilize the helicopter at that height.

## **2-22. Hovering Turns**

1. Apply pressure on the desired tail rotor pedal to begin the turn, using pressure and counter pressure on pedals as necessary to maintain constant rate of turn. Coordinate cyclic control to maintain the desired position over the selected pivot point while maintaining height with collective pitch control.

## **2-23. Sideward and Rearward Hovering Flight**

1. From a stabilized hover, apply cyclic control pressure in the desired direction of flight to begin sideward or rearward movement. Maintain the desired heading with the pedals and height with the collective. The speed should not exceed that of a brisk walk. To return to a stationary hover, apply cyclic pressure opposite the direction of movement while coordinating collective pitch and pedals to maintain the desired height and heading.

## **2-24. Hover Taxi**

1. From a stabilized hover, apply forward cyclic pressure to begin movement. Maintain the desired heading with the tail rotor pedals and height with the collective. The speed should not exceed that of a brisk walk. Changes in direction should be made primarily with pedal control to avoid excessive bank angles. To stop the forward movement, apply aft cyclic pressure while coordinating collective and pedals to maintain the desired height and heading.

## **2-25. Cyclic Trim**

1. As required.

## **2-26. Hover Check**

1. Perform the following checks at a hover:
  - a. Flight controls – Check flight controls for correct response.
  - b. Engine and transmission instruments – Check.
  - c. Flight instruments – Check as required.
- (O) (1) Altimeter and IVSI – Check for proper indications of climb and descent.
  - (2) Inclinator – Ball free in the race.

- (O) (3) Turn needle, heading indicator, and magnetic compass – Check for proper turn indications left and right.

### NOTE

**Hover turns in excess of 30° per second will cause the RMI/HSI compass system (if installed) display of heading to be inaccurate.**

- (O) (4) Attitude indicator – Check for proper indications of nose high and low, and banks left and right.
- (5) Airspeed indicator – Check airspeed.
- d. Engine power – Check. The power assurance check will allow the pilot to determine if sufficient power is available for takeoff and to achieve the performance calculated during the preflight preparation. The check is performed by establishing a stable hover and recording the pressure altitude, OAT, torque, and TOT. The actual TOT is then compared with the TOT determined from the power assurance check chart in Chapter 4. If the actual TOT is less than or equal to the chart TOT the pilot is assured that the helicopter will achieve flight manual calculated performance. As a final check, the actual torque required to hover is then compared with the predicted values from the performance chart in Chapter 4.

## 2-27. Before Takeoff

1. Immediately prior to takeoff, the following checks shall be accomplished:
- a.  $N_2$  – 103%
- b. Systems – Check engine, transmission, electrical, and fuel systems indications.

- c. Fuel – Check quantity.
- (O) d. Communications and navigation radios – Set.
- (O) e. Heading cross checked with wet compass.
- (O) f. Transponder – On as appropriate.
- g. Crew, passengers, and unused seats – Check seat belts and shoulder harnesses fastened.

## **2-28. Normal Takeoff**

1. Align the helicopter with the desired takeoff course at a stabilized hover of approximately 3 feet skid height or at an altitude permitting safe obstacle and terrain clearance. Smoothly apply forward cyclic pressure to begin acceleration into effective translational lift. As the helicopter begins its forward movement, additional collective pitch will be required to maintain altitude and forward and right cyclic trim will be required to maintain the cyclic forces near zero as the helicopter accelerates. Adjust the pedal pressure as necessary to maintain the desired heading. Control the rate of acceleration and direction of flight with cyclic and altitude with collective. Continue to accelerate at the required altitude until effective translational lift has been attained. Then, obstacles and terrain permitting, continue acceleration to 65 KIAS. Maintain 65 KIAS until reaching 400 feet AGL. After 400 feet AGL, establish best rate of climb airspeed in accordance with the Best Rate of Climb Speed chart (Figure 4-12). Continuous coordinated application of control pressures is necessary to maintain trim, heading, flight path, airspeed, and rate of climb. Refer to the Height-Velocity Diagram (Figure 4-13) for avoid areas.

2. A normal takeoff may be made from the ground by aligning the helicopter with the desired takeoff course on the ground and positioning the cyclic control slightly forward of neutral. Smoothly increase collective pitch to begin a climb to an altitude of approximately 3 feet (or an altitude permitting safe obstacle and terrain clearance) while simultaneously accelerating the helicopter. Continue takeoff as in the above paragraphs.

## 2-29. Maximum Power Takeoff Profiles

1. A takeoff that demands maximum performance from the helicopter may become necessary because of various combinations of heavy helicopter loads, restricted performance due to high density altitudes, barriers that must be cleared and other terrain features. The decision to use either of the following takeoff techniques must be based on an evaluation of the conditions and the helicopter performance.

2. Coordinated Climb. Align the helicopter with the desired takeoff course at a stabilized hover of approximately 3 foot skid height. Apply forward cyclic pressure smoothly and gradually while simultaneously increasing collective pitch to begin a coordinated acceleration and climb. Adjust pedal pressure as necessary to maintain the desired heading. Maximum torque available should be applied without exceeding helicopter limits and the attitude adjusted to accelerate to 48 KIAS at 10 feet. The climbout is continued at that power setting, accelerating and climbing to achieve 65 KIAS at 60 feet altitude. Then 65 KIAS is maintained until reaching 400 feet above ground level (AGL). After reaching 400 feet AGL, adjust the helicopter attitude to establish the best rate of climb airspeed and then adjust the collective and attitude as required to maintain a climb at the desired rate. Continuous coordinated application of control pressures is necessary to maintain trim, heading, flight path, airspeed, and rate of climb. Takeoff may be made from the ground by positioning the cyclic control slightly forward of neutral prior to increasing the collective pitch.

3. Level Acceleration. Align the helicopter with the desired takeoff course at a stabilized hover of approximately 3 feet skid height. Apply forward cyclic pressure smoothly and gradually while simultaneously increasing collective pitch to begin acceleration at approximately a 10 foot skid height. Adjust pedal pressure as necessary to maintain the desired heading. Maximum torque available should be applied without exceeding helicopter limits prior to accelerating through effective



translational lift. Additional forward cyclic pressure and trim will be necessary to allow for level acceleration to 65 KIAS climb speed. Approximately 5 knots prior to reaching 65 KIAS climb airspeed, gradually release forward cyclic pressure and allow the helicopter to begin a constant airspeed climb. After reaching 400 feet AGL adjust the helicopter attitude to achieve best rate of climb airspeed and then adjust the collective to establish a climb at the desired rate. Continuous coordinated application of control pressures is necessary to maintain trim, heading, flight path, airspeed, and rate of climb. Takeoff may be made from the ground by positioning the cyclic control slightly forward of neutral prior to increasing collective pitch.

4. Comparison of Techniques. Where the two techniques yield the same distance over a fifty foot obstacle when the helicopter can barely hover OGE, the coordinated climb technique will give a shorter distance over lower obstacles and the level acceleration technique will give a shorter distance over obstacles higher than fifty feet. As hover capability is decreased, the level acceleration technique gives increasingly shorter distances than the coordinated climb technique. In addition to the distance comparison, the main advantages of the level acceleration technique are: (1) It requires less or no time in the avoid area of the height-velocity diagram; (2) performance is more repeatable since reference to attitudes which change with loading and airspeed is not required; (3) at the higher climbout speeds the transition to autorotation should be more easily accomplished. The main advantage of the coordinated climb technique is that the angle of climb is established early in the takeoff and more distance and time are available to abort the takeoff if the obstacle cannot be cleared. Additionally, large attitude changes are not required to establish the climb airspeed.

## 2-30. Crosswind Takeoff

1. A crosswind takeoff does not require a significantly different technique than a takeoff into the wind. The primary difference is the requirement to hold the cyclic into the wind to prevent drift. For right crosswinds, additional power is required because of more left pedal being applied to maintain the desired heading.

## 2-31. Climb

1. After takeoff, select the airspeed and power necessary to clear obstacles. When obstacles are cleared, adjust the airspeed and power as desired at or above the maximum rate of climb airspeed. Refer to Chapter 4 for recommended airspeeds.

## 2-32. Cruise

1. When the desired cruise altitude is reached, adjust the power as necessary to maintain the desired airspeed. Refer to Chapter 4 for recommended airspeeds, power settings, and fuel flow.

## 2-33. Descent

1. Adjust power as necessary to attain and maintain the desired airspeed and rate of descent. Refer to Chapter 4 for power requirements at selected airspeeds and rates of descent.

## 2-34. Before Landing

1. Prior to landing the following checks shall be accomplished:

- a.  $N_2$  – 103%
- b. Systems – Check engine, transmission, electrical, and electrical indications.

- c. Fuel – Check quantity.
- d. Crew and passengers – Check.
- e. Landing lights – As required.

## **2-35. Approach and Landing**

1. Normal Approach. The approach begins by adjusting power as required to establish an approach angle of approximately 8 to 10 degrees at an airspeed above the minimum rate of descent airspeed specified in Chapter 4. Maintain the entry airspeed until the apparent ground speed and rate of closure appear to increase. From this point, progressively decrease the rate of descent and forward speed to stop all forward movement at approximately a 3 foot hover (or continue to the ground). As forward speed decreases below effective translational lift it will be necessary to gradually and smoothly increase collective pitch to terminate the approach. Refer to paragraph 2-35, Landing From A Hover. Refer to Chapter 4 for airspeeds, rates of descent and power requirements. Refer to the Height-Velocity Diagram, Chapter 4 for avoid areas during the approach.

2. Step Approach. A step approach is used as necessary to clear obstacles in the approach path. It is executed in the same manner as the normal approach except for the slower airspeeds that must be maintained throughout the approach. Approach angles may vary from that of a normal approach to a vertical descent. Because of the increased power requirements during termination, smooth and gradual collective pitch movements are very important.

3. Shallow Approach. A shallow approach is used as necessary when environmental or emergency requirements make it necessary to execute an approach at an angle less than that of a normal approach. It is executed in the same manner as a normal approach except that the deceleration may be more rapid. Approach angles may vary from that of a normal approach to approximately zero.

4. **Running Landing.** A running landing is used for some flight control malfunctions or for conditions where the helicopter cannot hover. The approach is shallow and flown at an airspeed that provides safe helicopter control. Airspeed is maintained as for a normal approach except that touchdown is made at an airspeed at or above effective translational lift. After ground contact is made, slowly decrease collective pitch to minimize forward speed. If braking action is necessary, the collective pitch may be lowered as required for quicker stopping.

### **2-36. Landing From A Hover**

1. From a stabilized hover, decrease collective pitch control to begin a gradual descent to touchdown making necessary corrections with pedals and cyclic control to prevent movement over the ground. Upon ground contact, continue to decrease collective pitch control smoothly and steadily until the entire weight of the helicopter is on the ground. Apply cyclic control as necessary to level the rotor system. For slope landings, make sure that the aircraft shows no tendency to slide or roll as the aircraft is lowered.

### **2-37. After Landing**

1. Landing lights – As required.
- (O) 2. Transponder – As required.

## 2-38. Engine Shutdown

1. Collective Pitch – Full down.
2. Collective friction – ON.

### NOTE

**On the last flight of the day, perform a deceleration check as described in paragraph 2-50.**

3. Throttle – Reduce to engine idle. Allow TOT to stabilize for two minutes. Check  $N_1$  speed 59-65%  $N_1$ .

(O) 4. Avionics – OFF.

5. All electrical switches – OFF except BATT, POS LTS, STRB LTS, BCN LTS.

---

### CAUTION

---

**MAIN GEN switch must be OFF before closing throttle to shut engine down.**

6. Throttle – Closed. Insure that after shutdown TOT is stabilized below 400°C. Either a TOT over 400°C or a TOT of 400°C and still rising are indications of a possible residual fire in the engine. In either case, press the starter switch with the throttle closed to motor the engine until the TOT is less than 200°C.

7. Lights – OFF (At night leave the lights on until the rotor stops for additional ground personnel safety.)

8. BATT switch – OFF

---

### CAUTION

---

**Do not drop the seat belt onto the floor. The heavy central latching mechanism may damage the honeycomb floor.**

## 2-39. Before Leaving Helicopter

1. Walk Around Inspection – Complete. Look for damage, and leaks, and check fluid levels as required.
2. Complete aircraft log book entries.
3. Secure Helicopter.

## 2-40. Night Flight

1. Before takeoff, it is imperative to ensure that all lights, instruments, and avionics equipment are functioning properly. Generally, interior lighting should be kept to the minimum amount which will still allow complete visibility of all instruments and gauges. Excessive cockpit lighting decreases outside visibility. Avoid using landing lights when in thick haze, dust, snow, smoke, or fog as reflected light will reduce visibility and may affect depth perception. During ground operations, the helicopter should be hovered/taxied slowly because it is difficult to judge actual ground speed and excessive speeds may be developed without realizing it.

### **SECTION III. PASSENGER BRIEFING**

#### **2-41. Passenger Briefing**

1. The following is a guide that should be used in accomplishing required passenger briefings. Items that do not pertain to a specific flight should be omitted.

a. Normal Procedures:

- (1) Entry and exit of aircraft
- (2) Seating
- (3) Seat belts (briefing is required by the FAA).
- (4) Internal communications
- (5) Security of equipment
- (6) Smoking

b. Emergency Procedures:

- (1) Emergency exits
- (2) Emergency equipment
- (3) Emergency landing/ditching procedures

## SECTION IV. ADVERSE ENVIRONMENTAL CONDITIONS

### 2-42. Cold Weather Operations

1. Operation of the helicopter in cold weather or an arctic environment presents no unusual problems if the operators are aware of those changes that do take place and conditions that may exist because of the lower temperatures and freezing moisture.

#### NOTE

**To ensure consistent starts at ambient temperatures below 4°C (40°F), it may be necessary to use JP-4, Jet B or a mixture of AVGAS and Jet A, Jet A1, or JP-5. See Chapter 8, "Handling, Servicing and Maintenance."**

### 2-43. Cold Weather Inspection

1. The pilot must be more thorough in the walk-around inspection when temperatures have been at or below 0°C (32°F). Water and snow may have entered many parts during operations or in periods when the helicopter was parked unsheltered. This moisture often remains to form ice which will immobilize moving parts or damage structure by expansion and will occasionally foul electric circuitry. Protective covers afford protection against rain, freezing rain, sleet, and snow when installed on a dry helicopter prior to precipitation. Since it is not practical to completely cover an unsheltered helicopter, joints and those parts not protected by covers require closer attention, especially after blowing snow or freezing rain. Accumulation of snow and ice should be removed prior to flight. Failure to do so can result in hazardous flight due to aerodynamic and center of gravity disturbances as well as the introduction of snow, water, and ice into internal moving parts and electrical systems. The pilot should be particularly attentive to the main and tail rotor systems and their exposed control linkages. Also, as temperatures



are reduced, the solubility of water in the fuel is markedly reduced. This results in water separating from the fuel and flowing to the lowest point in the tank, system, or accessory where it may later freeze. Under freezing conditions, it will form tiny ice crystals in the fuel which may be found impinged on the strainers, thus restricting fuel flow. Should this occur, there will be a drop in or loss of fuel pressure to the engine. The only remedy is to apply heat to the engine and fuel system components.

## WARNING

**If, at any time after engine start or during power application under low temperature conditions, the FUEL FILTER caution light comes on, the engine fuel filter may be blocked by ice crystals. If airborne, return and land, shut the engine down and apply pre-heat to the engine and the fuel system components to try to clear the condition. Drain fuel from all of the sump and system drains to ensure that all trapped water and crystals have been removed to the extent possible. As long as fuel will flow freely from the drains it can be assumed that the system is free from ice. Restart the engine. If the light re-illuminates, terminate engine operation and do not fly until the cause has been determined and corrected.**

## 2-44. Cold Weather Checks

1. Checks for temperatures below 0°C/32°F:
  - a. Before exterior check – Perform check as specified in Section II.
  - b. Exterior check – Perform exterior check as outlined in Section II, plus the following checks:
    - (1) Check pitot drain hole clear and unobstructed, cotter pin free.
    - (2) Check that all surfaces and controls are free of ice and snow.

### NOTE

**Contraction of the fluids in the helicopter systems at extreme low temperature causes indication of low levels. A check made just after the previous shutdown and carried forward to the walk-around check is satisfactory if no leaks are in evidence. Filling when the systems are cold soaked will result in an over fill condition with the possibility of forced leaks at seals.**

- (3) Main Rotor – Check free of ice, frost, and snow, and check for blade feathering freedom.
- (4) Engine –
  - (a) Inspect inlet for possible accumulations of snow, slush, or ice. Accumulations must be removed from the top of the fuselage beneath the particle separators and forward of the inlet on the top of the cabin.
  - (b) Inspect the plastic particle separator eductor tubes at the rear of the upper plenum for obstructions and snow. A thin film of ice

around the interior of each tube is acceptable. External ice adjacent to the eductor tube is also acceptable as long as the covers are free.

- c. Interior check – Perform check as specified in Section II.
- d. Engine starting check – Perform start and checks as outlined in Section II. (Use an external power unit if it is available.)

#### NOTE

**During cold weather when starting the engine the indicated oil pressure may exceed the maximum limit. The engine should be warmed up at engine idle until the indicated engine oil pressure is below 130 PSI.**

- e. Engine run up check – Perform the check as outlined in Section II.

#### WARNING

**Control systems checks should be performed with extreme caution when the helicopter is parked on snow and ice. There is reduction in ground friction holding the helicopter stationary, controls are sensitive and response is immediate.**

2. Engine Starting Without External Power. If a battery start must be attempted when the helicopter and battery have been cold soaked at temperatures below  $-26^{\circ}\text{C}/-15^{\circ}\text{F}$ , preheat the engine and battery if equipment is available and time permits. Preheating will result in a faster starter cranking speed which tends to reduce the hot start hazard by assisting the engine to reach a self sustaining speed.

## 2-45. Snow

1. Refer to Chapter 1, OPERATING LIMITATIONS, for additional limitations and information for operations in falling and blowing snow.

2. Takeoff. A takeoff in the snow should be considered as a normal takeoff except the following precautions should be observed:

- a. Loose or powdery snow will restrict visibility.
- b. Before attempting to takeoff, make sure that the landing gear skids are free and not frozen to the surface.

### WARNING

**Merely getting the helicopter light on the skids may not be a good indication that the skids are loose as only the oleos may be moving. To be sure that the helicopter is not frozen in place, pull enough power to get light on the skids and then yaw the aircraft a small amount with tail rotor pedal application to assure the freedom of movement. Be sure that the tail rotor is clear of any obstacles before performing this check.**

- c. Ensure that both the ENGINE ANTI-ICE and the SCAVENGE AIR are full ON prior to takeoff.

**WARNING**

**If the INLET AIR caution light illuminates as takeoff power is applied, abort the takeoff and investigate the cause of the caution light. This light is activated by a differential pressure switch that senses any inlet blockage sufficient to adversely affect engine power available.**

3. Landing – Landing in snow may be considered as a normal landing except for the following precautions:
  - a. If possible select an area free of loose or powdery snow so that visibility will not be restricted by blowing snow.
  - b. Accomplish a landing to the ground. Limited visibility will result from swirling snow when hovering is attempted before making the touchdown.
  - c. Anticipate loose, powdery snow and crusts on top of the snow on all landings on snow.
  - d. During landing, the reference point should be kept forward and to the left so that it will be visible to the pilot at all times.

**WARNING**

When making takeoffs and landings on snow, make the takeoff or the landing all one continuous operation without extended hover, in order to reduce the white-out condition that results from the rotor downwash impingement on the snow surrounding the helicopter. This white-out will usually occur on loose snow and can cause the pilot to lose all reference with the ground or any object he/she is approaching. If the ground and/or the object being used as a reference becomes completely obscured, accomplish a go-around.

**WARNING**

When landing to snow covered terrain it will often be impossible to judge the slope of the underlying ground. As the helicopter touches down be prepared to contact uneven terrain by allowing the skids to contact the ground in the normal manner for the termination of an approach to the ground, but reserve the final movement of the collective to full down flat pitch until you are sure that both skids are firmly in contact with the ground. Lower the collective slowly and be prepared for some attitude adjustment, particularly if there is a crust on the surface of the snow. Stay prepared to add collective and to reposition if the underlying terrain proves unsuitable for landing.

## 2-46. Desert and Hot Weather Operations

1. Typical problems encountered in desert operations are blowing dust and sand and high ambient temperatures.
2. Blowing dust and sand obscure vision and erode the leading edges of the rotor blades. All takeoffs and landings should be made from or to the ground.
3. High ambient temperatures affect the helicopter performance. Refer to Chapter 4.

### WARNING

**The engine is derated for this installation. As a result, throughout most of the operating envelope of the aircraft the usual power limit will be torque. When operating in high ambient temperature conditions, however, the engine will become the limiting factor and the pilot must be especially aware of the requirement to monitor the TOT and observe the appropriate time limits for operation of the engine in the yellow range for TOT. See Chapter 1, Operating Limitations.**

### CAUTION

**When operating in dusty or sandy environment ensure that the particle separator scavenge air is ON for ALL takeoffs and landings. Otherwise severe engine erosion and subsequent loss of power will occur.**

## 2-47. Icing Conditions

1. Intentional flight into any known icing conditions is prohibited. If icing conditions are encountered during flight, every effort should be made to exit the icing environment.

2. If icing conditions become unavoidable, the pilot should turn on the pitot heat (if equipped), windshield defog (if equipped), engine anti-ice, and particle separator scavenge air systems. Switch the static system to alternate if equipped.

3. During flights in icing the following conditions may be experienced:

- a. Obscured forward field of view due to ice accumulation on the windscreens.
- b. Increase in one per revolution rotor vibrations ranging from mild to severe caused by asymmetrical ice shedding from the main rotor system. The severity of the vibration will depend upon the temperatures and the amount of ice accumulation on the blades when the ice shed occurs. The possibility of an asymmetric ice shed occurring increases as the outside air temperature decreases.
- c. An increase in torque required to maintain a constant airspeed and altitude due to ice accumulation on the rotor system.
- d. Degradation of the ability to maintain autorotational rotor speed within the operating limits. If a 9% or greater torque pressure increase is required above the cruise torque setting used prior to entering icing conditions, it may not be possible to maintain autorotational rotor speed within operational limits should an engine failure occur.
- e. Loss of pitot and/or static system reference.



## NOTE

**Should the windshield defog fail to keep the windshield clear of ice, the side windows may be used for visual reference during landing. Sideslip during the approach to gain better visibility of the intended landing area.**

4. Control activity cannot be depended upon to remove ice from the main rotor system. Vigorous control movements should not be made in an attempt to reduce low frequency vibrations caused by asymmetrical shedding of ice from the main rotor blades. These movements may induce a more asymmetrical shedding of ice, further aggravating helicopter vibration levels.

## WARNING

**Ice shed from the rotor blades and/or other rotating components presents a hazard to personnel during landing and shutdown. Ground personnel should remain well clear of the helicopter during landing and shutdown and passengers/crewmembers should not exit the aircraft until the rotor has stopped turning.**

### 2-48. High Altitude Operations

1. High altitude operations pose no unusual problems to the operator with the sole exception of engine starts. In general, if the sea level setting on the engine start/acceleration adjustment is maintained, the starts may be excessively slow (60+ seconds) and cold. To ensure a proper start, the start/acceleration adjustment knob should be readjusted clockwise to increase the peak TOT of the start to 750-800°C (Refer to the Rolls-Royce Engine Operation Manual.) For example, if the takeoff airport elevation is 10,000 feet MSL, the acceleration knob should be rotated two to three clicks clockwise (but note that it needs to be turned back before attempting a start at lower altitude).

---

**CAUTION**

---

**If the engine start exceeds 800°C TOT, abort the start and adjust the start/acceleration knob one click counter clockwise for each 50°C TOT.**

**2-49. High Altitude Cold Weather Operation**

1. In addition to the procedures described in paragraph 2-47, when the aircraft has cold soaked at temperatures below 0°C/32°F, it is best to preheat the engine before start. Experience has shown that the engine start/acceleration adjustment may be rotated an additional two clicks clockwise (over and above the adjustment for altitude) for the first start of the day, and then after shutdown, readjusted counter clockwise two clicks so that subsequent engine starts or restarts will remain within approved limits.

---

**CAUTION**

---

**After the first cold start of the day, failure to remove the two-click clockwise start/acceleration knob adjustment that was used over and above the adjustment for altitude will result in the TOT exceeding starting limits for subsequent warm engine starts.**

**2-50. Deceleration Check**

Make the following deceleration check during the shutdown for the last flight of each day.

1. Turn unnecessary electrical equipment OFF.
2. Turn the generator switch OFF.

3. Position the twist grip to full open, hold collective at flat pitch and stabilize  $N_2$  at exactly 100% for approximately 15 seconds (beep as required).

---

**CAUTION**

---

**During rapid throttle movements, make appropriate anti-torque pedal corrections to prevent the aircraft from turning on loose or slick surfaces.**

4. Snap the twist grip to the IDLE position. Simultaneously start a time count using a stop watch or watch with a sweep second hand. Stop the time as the  $N_1$  needle passes through 65%. The minimum allowable deceleration time is two seconds.

**NOTE**

**Practice and/or retakes may be required before proficiency is obtained in timing the deceleration.**

a. If dual controls are installed, make separate deceleration checks using the pilot and copilot twist grips.

5. If deceleration time is less than two seconds, make two more checks to confirm the time. If the confirmed time is less than the minimum allowable time, refer to the Rolls Royce maintenance instructions.

6. If  $N_1$  speed drops below 59%, or if a flame out is experienced during the deceleration check, do not make second attempt. Refer to the Rolls Royce maintenance instructions.



**INTENTIONALLY LEFT BLANK**

## CHAPTER 3 EMERGENCY PROCEDURES

### TABLE OF CONTENTS

<u>SECTION</u>		<u>DESCRIPTION</u>	<u>PAGE</u>
		Table of Contents .....	3-1
Section I		General .....	3-5
Paragraph	3-1	Helicopter Systems.....	3-5
	3-2	Definition of Terms.....	3-5
	3-3	After Emergency Action .....	3-6
	3-4	Emergency Exit .....	3-6
Section II		Engine .....	3-7
Paragraph	3-5	Engine Failure.....	3-7
	3-6	Immediate Engine Relight.....	3-8
	3-7	Engine Restart – During Flight ...	3-9
	3-8	Autorotation.....	3-9
	3-9	Autorotation Profile .....	3-11
	3-10	Engine Failure in Cruise Flight.	3-13
	3-11	Engine Failure on or near the Height Velocity Diagram .....	3-15
	3-12	Engine Oil – Low Pressure/ High Temperature – Eng Oil Press Caution Light.....	3-20
	3-13	Engine Chip Caution Light .....	3-21
	3-14	Engine Inlet Air Caution Light ..	3-21
	3-15	Main Drive Shaft Failure .....	3-21
	3-16	Engine Overspeed .....	3-22
	3-17	Engine Underspeed .....	3-23
	3-18	Engine Surges .....	3-23
	3-19	Engine Compressor Stall .....	3-24
Section III		Rotors, Transmissions, and Drive Systems .....	3-25
Paragraph	3-20	Rotor RPM Light Illumination ...	3-25
	3-21	Tail Rotor Malfunction.....	3-25
	3-22	Main Xmsn Chip or Tail Chip Caution Light Illumination .....	3-29

**CHAPTER 3 EMERGENCY PROCEDURES****TABLE OF CONTENTS**

<u>SECTION</u>	<u>DESCRIPTION</u>	<u>PAGE</u>
	3-23 Main Rotor Gearbox Pressure Caution Light Illumination .....	3-29
	3-24 Main Xmsn Hot Caution Light Illumination .....	3-30
	3-25 Drive Bearing Hot Caution Light Illumination .....	3-30
Section IV	Fire .....	3-31
Paragraph	3-26 General .....	3-31
	3-27 Engine Compartment Fire – Flight .....	3-32
	3-28 Hot Start – Emergency Shutdown .....	3-33
	3-29 Engine Fire – Ground .....	3-33
	3-30 Fuselage Fire on the Ground .....	3-33
	3-31 Fuselage Fire – Flight .....	3-34
	3-32 Electrical Fire – Flight .....	3-34
	3-33 Electrical Fire – Flight (When Landing Cannot be Made Immediately .....	3-35
	3-34 Electrical Fire – Ground .....	3-36
	3-35 Smoke and Fume Elimination ...	3-36
Section V	Fuel System .....	3-37
Paragraph	3-36 Fuel Filter Caution Light Illumination .....	3-37
	3-37 Fuel Low Caution Light Illumination .....	3-37
Section VI	Electrical System .....	3-38
Paragraph	3-38 Lead-Acid Battery .....	3-38
	3-39 NiCad Battery .....	3-39
	3-40 Generator Malfunction – Zero Output .....	3-39
	3-41 Main Bus Failure .....	3-39

### CHAPTER 3 EMERGENCY PROCEDURES

#### TABLE OF CONTENTS

<u>SECTION</u>		<u>DESCRIPTION</u>	<u>PAGE</u>
Section VII		Ditching .....	3-40
Paragraph	3-42	General .....	3-40
Section VIII		Flight Control Malfunctions .....	3-42
Paragraph	3-43	Cyclic Control Vibration	
		Absorber Beam Failure .....	3-42
	3-44	Cyclic Trim Failure .....	3-42

**INTENTIONALLY LEFT BLANK**



## CHAPTER 3

### EMERGENCY PROCEDURES

#### SECTION I. GENERAL

##### 3-1. Helicopter Systems

1. This section describes the foreseeable helicopter and systems emergencies and presents the procedures to be followed. Emergency procedures are given in checklist form when applicable.

##### 3-2. Definition of Terms

1. Immediate Emergency Actions. Those actions that must be performed immediately in an emergency procedure are underlined. These immediate emergency actions must be committed to memory.

#### NOTE

**The urgency of certain emergencies requires immediate and instinctive action by the pilot. The most important single consideration is helicopter control. All procedures are subordinate to this requirement.**

2. Urgency to Land:

- a. Land Immediately - Perform a landing at the closest suitable landing site.
- b. Land as Soon as Practicable - Land at the nearest suitable airport or landing facility.

3. Throttle - Closed. Shut down the engine by rotating the throttle to the fully closed position. This requires pressing and holding the idle stop release to move the throttle past the idle position.

### **3-3. After Emergency Action**

1. After a malfunction of equipment has occurred, appropriate emergency actions have been taken and the helicopter is on the ground, an entry must be made in the remarks section of the aircraft log book describing the malfunction. The helicopter shall not be flown until corrective action has been taken.

### **3-4. Emergency Exit**

1. To exit the cabin in the event of an emergency, first attempt to open the doors. If the doors will not open, break the door windows, overhead windows, or windshields as the situation requires.

## SECTION II. ENGINE

### 3-5. Engine Failure

1. The indications of an engine failure, either a partial power loss or a complete power loss are:
  - a. A left yaw caused by the drop in torque applied to the main rotor.
  - b. A drop in engine (N<sub>2</sub>) RPM.
  - c. The ENGINE OUT warning light and audio triggered by the N<sub>1</sub> speed dropping below 58%.
  - d. A change in engine noise.

### WARNING

**Immediate reaction to an engine failure or power loss is essential. After immediate emergency actions have been accomplished, verify the engine failure by cross checking all of the engine instruments.**

2. Under partial power conditions, the engine may operate smoothly at reduced power or it may operate roughly and erratically with intermittent surges of power. In instances where a power loss is experienced without accompanying engine roughness or surging, the helicopter may sometimes be flown at reduced power to a favorable landing area; however, under these conditions the pilot should always be prepared for a complete power failure at any time. In the event that a partial power condition is accompanied by engine roughness, erratic operation, or power surging, close the throttle completely and perform an autorotational descent and landing. After an engine failure in flight, an engine restart may be attempted if time and altitude permit. Because the exact cause of engine failure cannot be determined in flight, the decision to attempt the

restart will depend on the altitude and time available, rate of descent, potential landing areas, and crew assistance available. Under ideal conditions, approximately 30-45 seconds is required to regain powered flight from the time the attempted start is begun if the start is commenced with an engine that is not windmilling. If the engine start button is depressed immediately after autorotation has been established, powered flight can usually be resumed within a matter of 20 to 25 seconds. There are two alternative types of restart that will be discussed below. The first is an immediate relight, the second is a restart from a full shutdown with the  $N_1$  below 15%.

#### NOTE

**Unless there is a reason to believe that the engine has failed due to some obvious mechanical failure, always attempt relight immediately after entering autorotation if time and altitude permit.**

### 3-6. Immediate Engine Relight

1. Although there is a formal step by step checklist provided below for engine restart in flight, if circumstances such as terrain or flight condition require an immediate relight attempt, the procedure need only involve two steps;

- a. Enter autorotation
- b. ENGINE START BUTTON - Depress and HOLD

2. The throttle does not have to be retarded to idle if the elapsed time between failure and attempted relight has not exceeded 5 seconds. There will be a slight surge as the engine comes back on line but it will be well controlled and will not damage the engine or drive train. To control the engine surge as it returns to flight RPM, it is recommended that the rotor RPM be reduced to minimum (334 RPM).

### 3-7. Engine Restart – During Flight

1. Autorotative glide - Establish
2. Attempt Start:
  - a. Throttle - Closed
  - b. Starter Button - Depress
  - c. Throttle - Idle ( $N_1$  15% or greater)
  - d. TOT and  $N_1$  - Monitor
  - e. Starter Button - Release (at 58%  $N_1$ )
  - f. Throttle - Advance to Full ON ( $N_2/N_R$  needles rejoined)
  - g. Powered Flight - Resume
3. Land Immediately - After the engine is started and powered flight is reestablished, perform a power on approach and landing without delay if the engine was not intentionally shutdown.

### 3-8. Autorotation

1. General - The 480B is a very forgiving helicopter following engine failure because of the high inertia rotor system and the excellent flying qualities in the transition from powered to unpowered flight. Following engine failure, the pilot will not experience any unusual pitch or roll attitude excursions, and there will be only a mild tendency for the aircraft to yaw to the left until the pilot applies right pedal to coordinate the aircraft. When the collective is lowered there is no pronounced tendency for the nose to tuck and the cyclic migration is normal. Should the corrective response to the failure be delayed more than normal, there is a wide transient rotor RPM band available for corrective action, down to 300 rotor RPM.

**WARNING**

**Rotor RPM recovery becomes very slow below 300 rotor RPM and the rotor RPM cannot be recovered below 240 rotor RPM. Never allow the rotor RPM to fall below 300 RPM in flight. In practice autorotations, if the rotor RPM falls below 300 rotor RPM, and the aircraft is not very close to touchdown (less than 1 foot), IMMEDIATELY bring the engine back on line to recover from the maneuver.**

2. Autorotation Entry - In general, autorotation entry is initiated by lowering the collective and adjusting the cyclic to maintain attitude. This is true in almost all of the flight conditions except when the aircraft is very close to the ground, such as hover in-ground-effect and high speed flight in the avoid area of the H-V Diagram. (See the discussion of techniques for autorotations in those instances). Cyclic control is adjusted as necessary to control airspeed and flight path after engine failure occurs in forward flight. Pedal pressure is applied as necessary to control aircraft trim and varies with airspeed and the amount of collective pitch applied at the time of engine failure.

3. Airspeed should be maintained between the minimum rate of descent and the maximum glide airspeeds at minimum power off rotor RPM, if conditions permit (see Chapter 4). Gliding the helicopter in autorotation out-of-trim will increase the rate of descent and decrease the glide distance, therefore correct tail rotor pedal control is important immediately after engine failure and during descent. If time permits during the autorotational descent, transmit a "Mayday" call, and set transponder to the appropriate emergency mode and code. The "Mayday" call must be made before the battery switch is turned OFF.

4. Descent - Minimum rate of descent and maximum glide are obtained at minimum rotor RPM. See Chapter 4, Performance, for appropriate airspeeds and further information.

### **3-9. Autorotation Profile**

1. Terminology - The terms used in the ensuing discussion are as follow:

- a. Minimum Transient Rotor RPM - The minimum transient rotor speed can and may be as low as 300 rotor RPM during the initial response time following engine failure and during the initial recovery control inputs.

#### **NOTE**

**Although operation below 334 RPM may be unavoidable during the initial stages of the autorotation, it should be minimized and immediate corrective action is required.**

- b. Minimum Rotor RPM - The minimum steady state rotor speed is 334 rotor RPM. This is the minimum allowable sustained rotor speed in steady flight, power Off.
- c. Minimum Flare Airspeed - The minimum flare airspeed is 50 KIAS. This is the minimum airspeed that will allow effective tradeoff of forward airspeed for rotor RPM in the flare prior to touchdown and efficient energy conversion to arrest the rate of descent. A 25 rotor RPM increase can be achieved from a flare at 50 KIAS.

2. Profile Intercept - Once the pilot has an understanding of the basic autorotation profile, he then determines what control inputs are necessary to maneuver the helicopter to intercept that profile following an engine failure. For example, if the airspeed is low, it will be necessary to lower the nose of the aircraft to increase the airspeed to achieve at least minimum flare airspeed. If the

airspeed is high it must be decreased to at least the maximum glide airspeed. If the height above the ground is high, there is obviously time to refine the descent. If the height above the ground is low, then other considerations govern pilot actions such as where the aircraft is relative to the "knee" of the H-V diagram. The point of this discussion is to emphasize the necessity for the pilot to know where the aircraft is operating relative to the H-V Diagram at all times.

## WARNING

**The Height-Velocity Diagram (Figure 4-13) is published to assist the pilot in defining the limiting combinations of height and airspeed below which it will be impossible to maneuver the helicopter to intercept the autorotation profile prior to touchdown. The most likely outcome for an engine failure within the boundaries of the H-V diagram is a crash landing.**

3. The procedures for profile intercept following an engine failure are therefore governed by the height and airspeed at the time of the engine failure, and the rotor RPM loss as a result of both normal pilot reaction time and the control motions required to maneuver the helicopter. The procedures described in the following paragraphs of this manual are guidelines for the specific conditions presented and cannot cover all possible flight conditions. In an actual situation these procedures must be modified by the pilot as necessary to meet the demands of the particular flight conditions and terrain below the helicopter at the time of the failure. Complete familiarity with the rotor system and helicopter autorotation characteristics through practice will ensure that the pilot will be able to make the correct decisions when faced with an actual engine failure.



**WARNING**

**It is essential that the pilot understand that the autorotation characteristics experienced in practice with the engine at idle are NOT identical to those that will be experienced when the engine actually fails. In practice autorotations, there is both some residual engine net jet thrust as well as rotor speed support by the idling N<sub>2</sub> turbine. In the final pitch pull prior to touchdown, with the engine at idle, there can be a significant power contribution by the engine. The rate of descent will be faster and the rotor and glide path management more critical with the engine out.**

### **3-10. Engine Failure in Cruise Flight**

1. Collective - Down. Regain and maintain Autorotational RPM.
2. Autorotational Glide - Establish. Use collective to maintain RPM within limits.
3. Flare and Land.
4. Fuel Valve Handle - OFF. Prior to landing if possible.
5. BATT Switch - OFF. If time permits during the descent the FUEL valve and the BATT switch should be turned OFF and the N1-N2-NR-TOT switch turned to BATT prior to touchdown to reduce the possibility of fire.

6. Engine failure in cruise flight results in the most familiar of the autorotation entries resulting in either a straight-in or turning autorotation descent and landing. In the case of straight-in and turning touchdown autorotations in training, the pilot almost always intercepts the profile in the glide phase. Airspeed and rotor speed are then adjusted to achieve the desired glide characteristics to arrive at the desired touchdown point with the rotor energy managed to allow proper termination and touchdown. Based on the height of the aircraft above the terrain, terrain available for landing, gross weight, and density altitude, the rotor RPM and airspeed can be varied to achieve the desired descent and glide characteristics.

### **3-11. Engine Failure on or near the Height Velocity Diagram**

#### **1. High Hover Point.**

- a. Collective - FULL Down.
- b. Helicopter Attitude - 20 degrees Nose Down  
Immediately Accelerate immediately to minimum flare airspeed (50 KIAS).
- c. Flare and Land.
- d. Fuel Valve Handle - OFF
- e. BATT Switch - OFF.

f. The high hover point on the H-V Diagram has been established as that point where, following engine failure, the pilot has just enough altitude to execute a safe autorotation. This is best accomplished as follows: immediately lower the collective full down, lower the nose of the helicopter to 20 degrees nose down attitude, accelerate to 50 KIAS and immediately enter the flare to regain RPM and arrest the rate of descent prior to completing the final pitch pull and touchdown. In this autorotation the helicopter ends up intercepting the autorotation profile in the flare. Although the entry to autorotation from this condition is seldom taught, it is essential that the pilot understand exactly what control inputs are necessary to successfully maneuver the aircraft to intercept the autorotation profile. The first two actions, following engine failure, must occur almost simultaneously; first, the collective must be placed full down, to preserve rotor RPM; Second, the cyclic must be quickly displaced forward, sufficiently to place the helicopter in a 20 degree nose down attitude, to allow it to accelerate to minimum flare airspeed.

g. Because the entry is unusual, and possibly not familiar to the pilot, the maneuver deserves some additional discussion. First, when the cyclic is displaced forward to lower the nose of the helicopter there will be some additional incremental loss of rotor RPM due to cyclic displacement, (approximately 10 - 15 RPM more than that already lost during the normal pilot reaction time in lowering the collective). The pilot should not be alarmed by this, as long as it does not go below the minimum transient rotor speed of 300 RPM. Such an additional loss of RPM is normal and has been taken into account in developing the H-V diagram. Second, the 20 degree nose down attitude is not arbitrary but instead represents the optimum compromise between all of the factors involved. If a steeper attitude is used the rotor RPM loss will be greater, the required flare airspeed has to be higher, and the altitude loss required to achieve that higher airspeed will be greater. Additionally, the attitude changes at the bottom of the maneuver become more extreme with very little gain and much more risk of striking the ground with the tail in the flare. If the attitude is more shallow than 20 degrees nose down, then minimum flare airspeed will not be achieved prior to ground contact with the resultant that the pilot will be unable to efficiently tradeoff energy at bottom of the autorotation to arrest the rate of descent.

## **2. Engine Failure Between the High Hover Point and the Knee**

- a. Collective - FULL Down.
- b. Helicopter Attitude - Nose Down As Required  
Accelerate immediately to, or maintain minimum flare airspeed (50 kt).
- c. Flare and Land.
- d. Fuel Valve Handle - OFF
- e. BATT Switch - OFF

f. Autorotation entry between the high hover point on the H-V Diagram and the "knee" will be a variation of the technique used for the high hover point. As always, the collective must be lowered to full down immediately to preserve rotor RPM, and the pitch attitude adjusted as necessary to gain or maintain the minimum flare airspeed. At higher initial entry airspeeds there will be less nose down pitch attitude required to regain minimum flare airspeed. Where the aircraft intercepts the autorotation profile depends on how much maneuvering and altitude loss is required to achieve minimum flare airspeed. The intercept point may be anywhere from some point in the final stages of the glide to the flare.

### **3. Engine Failure at Low Hover (in-ground-effect)**

- a. Collective -Maintain.
- b. Heading - Maintain.
- c. Land. Time the pitch pull to cushion the landing.
- d. Fuel Valve Handle - OFF
- e. BATT Switch - OFF

f. A hovering autorotation, in-ground-effect, presents no unusual problems to the pilot. In general the collective is maintained in position after the engine failure and the aircraft allowed to settle to near ground contact before the final collective pull is accomplished. The cyclic should be used to maintain position over the ground and the pedals to maintain zero yaw rate.

g. If the aircraft, at the time of the engine failure, is hovering at a height above the maximum hover in-ground-effect height at the bottom of the H-V Diagram then the pilot will have to consider partially or completely lowering the collective to try to preserve as much rotor RPM as possible during the descent. He should then rapidly pull all available collective just prior to ground contact to try

to cushion the landing. The oleo struts and landing gear crosstubes should absorb most of the impact forces. Depending on the aircraft height above the ground at the time of the engine failure, the pilot may elect to attempt some variation of the maneuver necessary for the high hover point to try to minimize the impact with the ground. There is no experience in this area available to advise the pilot of the correct actions to take.

#### NOTE

**During practice “hover” autorotation, allow the N2 to return to 64% and stabilize before advancing the throttle to the governed range. Keep torque below 30 PSI while advancing the throttle to prevent compressor surges.**

#### 4. Engine Failure on Takeoff - Below 40 KIAS

#### NOTE

**The procedures discussed for engine failure during takeoff and the technique used to develop the H-V Diagram are based on using the airspeed-over-altitude level accelerating takeoff, where the aircraft is accelerated to 65 KIAS initial climbout airspeed at a constant skid height of 10 feet and the alternate procedure of accelerating to 48 KIAS at 10 feet then an accelerating climb to 65 KIAS at 60 feet.**

- a. Collective -Adjust. Lower as necessary to preserve rotor RPM, full down if possible.
- b. Flare as Required and Land.
- c. Fuel Valve Handle - OFF
- d. BATT Switch - OFF

e. If the engine failure occurs during the initial takeoff run, the procedures will essentially be those for the hover in-ground-effect engine failure described above. If the collective was increased to obtain power levels greater than that for stabilized hover for the takeoff, the pilot should at least partially reduce the collective pitch to preserve as much rotor RPM as possible prior to the landing. Below 30 KIAS no flare should be attempted as the proximity of the ground will increase the likelihood of a tail rotor strike and there will be no benefit to rotor speed. The aircraft attitude should be adjusted to slightly nose up to assist in slowing the forward speed as the aircraft is cushioned onto the ground with the collective.

## **5. Engine Failure on Takeoff - 40 KIAS to the Knee**

- a. Collective -Full Down. Establish autorotation glide.
- b. Flare and Land.
- c. Fuel Valve Handle - OFF
- d. BATT Switch - OFF

e. If the engine failure occurs during the final phase of the takeoff run, just prior to or after rotation to begin climb out, the pilot must immediately transition to the flare for touchdown. Collective must be immediately lowered to full down, the cyclic used to adjust the aircraft attitude from an accelerating attitude to a decelerating attitude, and the pedals adjusted to maintain the aircraft aligned with the takeoff path. Depending on the altitude of the aircraft at the engine failure, the aircraft may intercept the autorotation profile at the flare or, if near the knee, in the final portion of the glide. If takeoff power had been applied at takeoff, and prior to the engine failure, the pilot's corrective actions must be more positive to arrest rotor RPM decay and to arrest the rate of descent prior to touchdown.

**6. Engine Failure - High Speed Low Altitude** (10 feet and above)

- a. Collective - Adjust as required for tail rotor clearance and to maintain main rotor rpm.
- b. Cyclic - Adjust to achieve a 10° to 15° nose up decelerating attitude.
- c. Land - level aircraft prior to touchdown.
- d. Fuel Valve - OFF
- e. BATT Switch - OFF

f. If the engine fails at high speed and low altitude above the ground the corrective action will greatly depend upon how much room there is to safely maneuver. In general, if there is at least 10 feet of skid height, the pilot can safely maintain a constant decelerating attitude until just prior to touchdown. Once again, the primary goal is to intercept the autorotation profile, and in this case it will be in the flare. Caution must be exercised to avoid striking the tail rotor.

**3-12. Engine Oil - Low Pressure/High Temperature - Eng Oil Press Caution Light Illuminated**

1. If engine oil pressure drops below the operating limit, or oil temperature increases above the operating limit or the ENG OIL PRESS caution light illuminates, accomplish a power on approach and landing immediately. If these conditions exist over terrain not suitable for landing, flight may be continued at reduced power to a favorable landing area; however, under these conditions the pilot should always be prepared for a complete engine failure.



### 3-13. Engine Chip Caution Light

1. If the ENG CHIP caution light illuminates, accomplish a power on approach and landing immediately. If these conditions exist over terrain not suitable for landing, flight may be continued at reduced power to a favorable landing area; however, under these conditions the pilot should always be prepared for a complete engine failure.

### 3-14. Engine Inlet Air Caution Light

1. If the ENG INLET AIR caution light illuminates, pull the engine Scav-Air control handle full on, reduce power and accomplish a power on approach and landing as soon as practicable. The caution light is activated by a differential pressure switch that measures the pressure drop across the swirl tube particle separator system into the lower plenum and indicates a partial blockage of the swirl tubes. Once the aircraft has been landed and shut down, investigate and correct the cause of the blockage prior to continuing flight.

### 3-15. Main Drive Shaft Failure

1. A failure of the main drive shaft will be indicated by a sudden increase of engine RPM and decrease of rotor RPM, and activation of the LOW ROTOR RPM warning light and audio. A transient overspeed of  $N_1$  and  $N_2$  may occur but will stabilize as fuel topping limits are reached and the overspeed governor assumes control of the engine. The indications to the pilot will initially be conflicting and confusing, therefore, the initial reaction should be the same as for an engine failure. Once autorotation has been established, the pilot will be able to sort out the nature of the failure. In the event of driveshaft failure proceed as follows:

- a. Collective Pitch - Down Establish autorotational glide.
- b. Throttle - Close

c. Land Accomplish autorotational descent and landing.

d. Fuel Valve - OFF

e. BATT Switch - OFF If time permits during the descent the FUEL valve and the BATT switch should be turned OFF and the N1-N2-NR-TOT switch turned to BATT prior to touchdown to reduce the possibility of fire.

### 3-16. Engine Overspeed

1. If an engine overspeed occurs, proceed as follows:

a. Collective Pitch - Increase to load the rotor and sustain engine RPM below the maximum operating limit.

b. Throttle - Reduce until normal operating RPM is attained.

c. Land - Perform a power on approach and landing by controlling the throttle manually.

2. If RPM cannot be controlled manually, proceed as outlined in the following steps:

a. Throttle - Closed when over a safe landing area.

b. Collective Pitch - Down establish autorotational glide.

c. Land

d. Fuel Valve - OFF

e. BATT Switch - OFF If time permits during the descent the FUEL valve and the BATT switch should be turned OFF and the N1-N2-NR-TOT switch turned to BATT prior to touchdown to reduce the possibility of fire.

### 3-17. Engine Underspeed

1. If an engine under speed is experienced, proceed as follows:
  - a. Check Throttle - Full ON and GOV INCR-DECR switch setting.
  - b. Lower Collective as required to see if RPM will come back and be held.
2. If RPM does not come back then do the following:
  - a. Collective Pitch - Down Establish autorotational glide.
  - b. Throttle - Closed
  - c. Land
  - d. Fuel Valve - OFF
  - e. BATT Switch - OFF If time permits during the descent the FUEL valve and the BATT switch should be turned OFF and the N1-N2-NR-TOT switch turned to BATT prior to touchdown to reduce the possibility of fire.

### 3-18. Engine Surges

1. If surges in engine RPM are experienced proceed as follows:
  - a. GOV INCR/DECR Switch - Increase for maximum RPM
  - b. Throttle - Reduce to 101% N<sub>2</sub>
  - c. Land Immediately Perform a power on approach and landing without delay.
2. If engine surges cannot be controlled using the procedure above, proceed as outlined in the following steps:
  - a. Throttle - Closed when over a safe landing area.

- b. Collective Pitch - Down establish autorotational glide.
- c. Land
- d. Fuel Valve - OFF
- e. BATT Switch - OFF If time permits during the descent the FUEL valve and the BATT switch should be turned OFF and the N1-N2-NR-TOT switch turned to BATT prior to touchdown to reduce the possibility of fire.

### 3-19. Engine Compressor Stall

1. Engine compressor stall (surge) is characterized by a sharp rumble or a series of loud sharp reports, severe engine vibration, and a rapid rise of TOT, depending on the severity of the surge. Maneuvers requiring rapid or maximum power applications should be avoided. Should the compressor stall continue, the following steps should be accomplished:

- a. Power - Reduce
  - b. Engine Anti-ice - OFF
  - c. Heater - OFF
  - d. Defog - OFF
  - e. SCAV AIR - OFF unless in snow or ice.
2. If the stall still persists;
- a. Land - As soon as practicable.
  - b. After landing perform normal shutdown.

## **SECTION III. ROTORS, TRANSMISSIONS, AND DRIVE SYSTEMS**

### **3-20. Rotor RPM Warning Light Illumination**

1. If the ROTOR RPM warning light illuminates, immediately lower the collective to increase the RPM or raise the collective to reduce the RPM as required to return the RPM to the normal operating range. The only exception to this requirement is when the light illuminates because the RPM is low during an autorotational flare immediately prior to touchdown. After adjusting the collective, continue to monitor the tachometer and control the RPM by manipulating the collective.

### **3-21. Tail Rotor Malfunctions**

1. Because of the many different malfunctions that can occur, it is not possible to provide a solution for every emergency. The success in coping with the emergency depends on quick analysis of the condition and selection of the proper emergency procedure. The following is a discussion of some of the types of malfunctions, probable effects, and corrective actions.

2. Complete Loss Of Tail Rotor Thrust - This is a situation involving a break in the drive system, such as a severed drive shaft, sheared gears, or broken flex packs, wherein the tail rotor stops turning. This same type of situation can occur if the tail rotor controls fail with the tail rotor in a zero pitch condition, and no thrust delivered by the tail rotor. A failure of this type in forward flight will result in the nose of the helicopter turning to the right (left sideslip) and a left roll of the fuselage along the horizontal axis. Execution of an autorotative approach is the only proper emergency procedure.

a. In powered flight, the degree of sideslip and the degree of roll may be varied by changing airspeed and by varying power (throttle or pitch), but neither can be eliminated. Below an airspeed of approximately 45 knots, the sideslip may become uncontrollable, and the aircraft may begin to revolve on its vertical axis. If complete tail rotor thrust is lost during hovering flight execute a hovering autorotation.

b. In power off flight (autorotation), following the failure, the sideslip and roll angle can be almost completely eliminated by maintaining an airspeed of 48 to 80 knots. Turns should be kept to a minimum but when required all turns should be made to the right if possible. When airspeed is decreased through approximately 20 to 30 knots, streamlining effect will be greatly reduced and the sideslip may become uncontrollable. If the landing area is a smooth hard surface, a run on landing should be made with a touchdown airspeed between 15 and 25 knots. If the surface is unprepared, start to decelerate from 75 feet altitude so that forward ground speed is at a minimum when the helicopter reaches 10 to 20 feet. Execute the touchdown with a rapid collective pull just prior to touchdown. Touchdown in a level attitude with minimum ground slide (zero if possible). Upon pitch application at touchdown the fuselage will tend to turn in the same direction as the main rotor is turning (left) due to an increase of friction in the transmission system. If the aircraft touches down with zero forward speed then hold the aircraft level and let it land with rotation. If there is forward speed, as the aircraft begins to turn on the surface in the slide follow the turn with the cyclic.

3. Fixed Pitch Setting - This is a malfunction involving a loss of control resulting in a fixed pitch setting. This can be caused by such failures as a tail rotor control cable becoming jammed or by a control cable being severed. Normally under these circumstances the directional pitch setting that is in the tail rotor at the time of the failure will, to some degree, remain for the rest of the flight. Whether the nose of the aircraft yaws to the left or right is dependent upon the amount of pedal (which is related to power) applied at the time of the failure.

a. If the tail rotor pitch becomes fixed during an approach or other reduced power situation (right pedal applied) the nose of the aircraft will turn right when power is applied, possibly to an even greater extent than would be experienced with complete loss of tail rotor thrust, and the overall situation may be even more hazardous. The best solution may not be to autorotate. Whether a successful autorotation could be accomplished is not certain and is

dependent upon the amount of pitch applied at the time of the failure. A shallow approach and running landing may be more preferable. The aircraft yaw angle can usually be adequately controlled by manipulation of the throttle just prior to touchdown and during the rollout. The pilot can easily remember which way the nose will respond to the throttle movement by grasping the twist grip with the index finger pointed down. As the hand is rotated the index finger will indicate the direction the nose will turn, ie rotation to reduce throttle will cause the nose to turn left and vice versa. As the shallow approach is commenced the throttle should be reduced sufficiently to gain manual control of the engine and reduce the rotor RPM to the low side of the power on operating range. The approach should be made to take advantage of the full length of the runway. As the aircraft crosses over the landing threshold the airspeed should be slowly reduced to arrive at an airspeed at or above effective translational lift (ETL) just as the aircraft touches down. Just prior to touchdown the throttle should be rolled off (reduced) sufficiently to cause the nose of the aircraft to swing left and align with the runway. As the aircraft touches down and rolls out the throttle can be manipulated to control aircraft heading; "on" to yaw right, "off" to yaw left. As the aircraft slides to a halt, if it has any tendency to turn, follow the turn with the cyclic. Do not cross control or resist the turn with the cyclic.

b. If the tail rotor becomes fixed during a takeoff or other increased power situation (left pedal applied) the nose of the aircraft will turn left when power is reduced (as in leveling off with cruise power). Under these circumstances an autorotative landing must not be attempted. It is usually possible to continue powered flight to an airfield and to perform a powered running landing. Depending upon the power setting at the time of the failure, the sideslip angle will probably be almost completely eliminated when power is applied for touchdown. When the approach is commenced, the engine N2 RPM should be manually decreased to 100%. The sideslip angle will increase as will the requirement for a considerable amount of right cyclic, however this will be corrected when power is

applied to terminate at touchdown. Due to this sideslip on the approach, a higher than normal approach speed may be beneficial. In this instance powered landing may be the best solution and it is unlikely that an autorotation can be accomplished at all.

c. If the tail rotor becomes fixed during normal cruise power setting, the helicopter reaction should not be as pronounced as in the previously described situations and, at speeds from 40 to 80 knots, the tail should streamline with very little sideslip or fuselage roll angle. In this instance, autorotation may aggravate the situation because a reduction of power (torque) may then result in a right sideslip (left yaw). It must be considered, however, that an increase in power at touch down will result in a left sideslip (right yaw) if a powered approach is used. The first thing the pilot must do in this situation is to determine what power setting results in balanced flight. That power (torque) setting then can be related to the power required for initial hover. If the cruise power for balanced flight is more than that required for the initial hover then the pilot will most likely be able to return to a hover. If the power is less than the initial hover power then possibly a running landing may be the best solution with a very low touchdown speed and throttle manipulation similar to that described in the fixed right pedal failure section of this chapter.

4. Complete Loss of Tail Rotor or Components - The seriousness of this situation is dependent upon the amount of weight lost. Any loss of this nature will result in a forward center of gravity shift. Immediate autorotation may be the only solution of possible value.



### **3-22. Main XMSN Chip or Tail Chip Caution Light Illumination**

1. If the MAIN XMSN CHIP or the TAIL CHIP caution lights illuminate accomplish a power on approach and landing as soon as practicable.

### **3-23. Main Rotor XMSN Pressure Caution Light Illumination**

1. If the XMSN PRESS caution light illuminates, land as soon as practical.

a. After landing and shutdown, inspect the main rotor transmission filtration/cooling system for oil leaks and broken oil lines. Inspect the main rotor transmission for proper oil level.

b. If no oil leaks or broken oil lines are found and the main rotor transmission has the proper oil level, the fault is either a pump failure or a pressure switch failure. Open the XMSN PUMP circuit breaker and continue operation of the aircraft to the final destination.

c. After arrival at the final destination, repair the filtration/cooling system before continuing operation of the aircraft.

2. If the XMSN PRESS and the MAIN XMSN HOT caution lights are illuminated, verify the temperature indication by referring to the main transmission temperature gauge. If the high temperature indication appears to be valid, perform a power on approach and landing immediately.

### **3-24. Main XMSN Hot Caution Light Illumination**

1. If the MAIN XMSN HOT and the MAIN XMSN CHIP caution lights are both on, or the MAIN XMSN HOT caution light illuminates without apparent cause--such as prolonged hovering at high ambient temperature--verify the temperature indication by referring to the main transmission temperature gauge. If the high temperature indication appears to be valid, perform a power on approach and landing immediately.

2. If the MAIN XMSN HOT caution light illuminates after prolonged hovering in high ambient temperatures, proceed as follows:

a. Verify the indication by referring to the main transmission temperature gauge.

b. If at a hover, proceed into forward flight at 60KIAS. The temperature should stabilize and begin decreasing within a few minutes.

c. If, after 10 minutes of forward flight, the temperature doesn't decrease sufficiently to extinguish the caution light (below 100°C), land immediately.

### **3-25. Drive Bearing Hot Caution Light Illumination**

1. If the DRIVE BEARING HOT caution light illuminates, accomplish a power on approach and landing immediately. If this condition occurs over terrain not suitable for a landing, flight may be continued at reduced power to a favorable landing area; however, under these conditions the pilot should be prepared for a partial power loss or drive system failure at any time.

## SECTION IV. FIRE

### 3-26. General

1. The safety of the occupants of the aircraft is the primary consideration when a fire occurs. On the ground it is essential that the engine be shut down, crew and passengers evacuated, and fire fighting efforts be commenced with the hand held extinguisher at the discretion of the pilot. If time permits, a "MAYDAY" radio call should be made before the electrical power is shut off to expedite assistance from airfield fire fighting equipment and personnel. If the helicopter is airborne when a fire occurs, the most important single action that can be taken by the pilot is to land the helicopter immediately.

### WARNING

**Some hand held fire extinguishers (e.g., Halon) contain toxic fumes. Use these hand held fire extinguishers only in well ventilated areas because the toxic fumes of the extinguishing agent may cause injury.**

### 3-27. Engine Compartment Fire – Flight

1. When the FIRE warning light illuminates it is essential that the following immediate action steps be taken, altitude and time permitting:

a. Collective pitch - Down enter autorotation.

b. Throttle - Idle

c. Fire Warning Light - Note If FIRE warning light extinguishes within 10-15 seconds, resume powered flight at a reduced power level and land as soon as practicable, as this is symptomatic of a cracked combustor case.

2. If the FIRE warning light is still illuminated proceed as follows:

a. Throttle - close

b. Land Accomplish autorotating descent and landing.

c. Fuel Valve - OFF

d. BATT Switch - OFF If time permits during the descent the FUEL valve and the BATT switch should be turned OFF and the N1-N2-NR-TOT switch turned to BATT prior to touchdown.

e. Clear the helicopter of all passengers and crew immediately and if practical fight the fire with the hand held cockpit fire extinguisher.

### 3-28. Hot Start – Emergency Shutdown

1. The following procedure is applicable during engine starting if flames are emitted from the exhausts, TOT limits are exceeded, or it becomes apparent that TOT limits will be exceeded.

a. Throttle - Close The throttle must be closed immediately.

b. Starter switch - Continue to press The starter switch must be held until the TOT is in the normal operating range.

c. Fuel Valve - OFF

### 3-29. Engine Fire – Ground

1. Throttle - Close

2. Fuel Valve - OFF

3. BATT Switch - OFF

4. Clear the helicopter of all passengers and crew immediately. If practical, fight the fire with the hand held cockpit fire extinguisher.

### 3-30. Fuselage Fire on the Ground

1. If fire is observed in any part of the helicopter during ground operations proceed as follows:

a. Throttle - Closed

b. Fuel Valve- OFF

c. BATT Switch - OFF

d. Clear the helicopter of all passengers and crew immediately and if practical fight fire with cockpit fire extinguisher.

### 3-31. Fuselage Fire – Flight

1. If fire is observed in any part of the helicopter in flight, proceed as follows:

a. Land Immediately Perform a power-on approach and landing without delay.

b. Throttle - Close as soon as the helicopter is on the ground.

c. Fuel Valve - OFF

d. BATT Switch - OFF

e. Clear the helicopter of all passengers and crew immediately and if practical fight fire with cockpit fire extinguisher.

### 3-32. Electrical Fire – Flight

1. In the event of electrical fire or suspected electrical fire in flight, including avionics, battery, and other electrical components, proceed as follows:

a. MAIN GEN Switch - OFF

b. BATT Switch - OFF

c. N1-N2-NR-TOT Switch - BATT

d. Land Immediately Perform a power on approach and landing without delay.

e. Engine Shutdown After landing complete as follows:

(1) Throttle - Closed

(2) Fuel Valve - OFF

f. Clear the helicopter of passengers and crew immediately.

### **3-33. Electrical Fire – Flight (When Landing Cannot Be Made Immediately)**

1. In the event a landing cannot be made immediately and flight must be continued, the defective circuits may be identified and isolated as follows:

a. Complete steps “a” thru “c” of paragraph 3-32 above.

b. Circuit breakers - Out

#### **NOTE**

**As each of the following steps is accomplished, check for indications of the source of the fire.**

c. MAIN GEN Switch - ON

d. BATT Switch - ON

e. Circuit Breakers - In one at a time in the priority required. Monitor the ammeter. When the malfunctioning circuit is identified, pull the applicable circuit breaker out and leave it out for the duration of the flight. A malfunctioning circuit can be identified by recurrence of the smoke or fire, and possibly a sharp increase in the electrical load as the circuit breaker of the malfunctioning circuit is pushed in.

### 3-34. Electrical Fire – Ground

1. In the event of electrical fire or suspected electrical fire during ground operations, proceed as follows:

- a. Throttle - Close
- b. Fuel Valve - OFF
- c. BATT Switch - OFF
- d. Clear the helicopter of passengers and crew immediately.

### 3-35. Smoke and Fume Elimination

1. Smoke and/or toxic fumes entering the cockpit and cabin can be exhausted as follows:

- a. Vents - Open
- b. Defog, Heater, and Fresh Air Valves - ON

#### NOTE

**If smoke is coming from the defog, heater, or fresh air system, turn them OFF.**



## **SECTION V. FUEL SYSTEM**

### **3-36. Fuel Filter Caution Light Illumination**

1. If the FUEL FILTER caution light illuminates, perform a power on approach and land as soon as practicable.

### **3-37. Fuel Low Caution Light Illumination**

1. When the FUEL LOW caution light illuminates, there are approximately five gallons of fuel remaining. At normal power settings this will last approximately ten minutes. Note the time when the light illuminates and plan a landing prior to fuel exhaustion. Avoid excessive maneuvering which might cause fuel to slosh and unport the fuel tank outlet.

**SECTION VI. ELECTRICAL SYSTEM****3-38. Lead-Acid Battery**

1. "Shorting" malfunction of the lead-acid battery will cause high amperage readings. If excessively high amperage is noted with no apparent cause:

- a. MAIN GEN Switch – Off.

2. Then, if the electrical equipment stops operating and/or the voltmeter indicates very low voltage (e.g. below 20 volts):

- a. BATT Switch – Off.
- b. AVIONICS Switch – Off.
- c. MAIN GEN Switch – On. Monitor ammeter.

3. Then, if the electrical systems operate normally and the amperage is appropriate:

- a. AVIONICS Switch – On.
- b. LAND – as soon as practicable. Make an entry in the aircraft log book.

**3-39. NiCad Battery**

1. BATTERY TEMP caution light illuminated:

- a. BATT Switch - OFF and leave OFF even if the BATTERY TEMP light goes out.
- b. LAND - as soon as practicable and have maintenance personnel investigate the cause. Make an entry in the aircraft log book.

2. BATTERY HOT warning light illuminated:

- a. BATT Switch - OFF
- b. LAND - Immediately. Make an entry in the aircraft log book.

### 3-40. Generator Malfunction – Zero Output

1. A failure of the generator will be indicated by a zero indication on the ammeter and a DC GEN caution light illuminating. The voltmeter will indicate battery voltage. An attempt may be made to put the generator back on line by accomplishing the following:

- a. GEN FIELD circuit breaker - IN
- b. MAIN GEN Switch - OFF then ON (S/N's 5039 - 5076 and 5078 - 5084) or RESET then ON (S/N's 5077, 5085 and subsequent).
- c. If the main generator does not come back on line or if it goes off the line again, MAIN GEN Switch OFF. Turn off all unnecessary electrical equipment and land as soon as practicable.

### 3-41. Main Bus Failure

1. In the event of a complete main electrical bus failure, the dual ( $N_2/N_R$ ) tachometer, gas producer ( $N_1$ ) tachometer, and TOT indications can be restored by positioning the  $N_1-N_2-NR-TOT$  switch from BUS to BATT. All other systems and indicators which are absolutely necessary for flight in visual meteorological conditions will continue to function without electrical power. Most of the other aircraft systems, however, such as warning, navigation, and communication systems will be inoperative. Land as soon as practicable.

## SECTION VII. DITCHING

### NOTE

**The following information is presented to provide the pilot with the best information possible in the event that a forced landing must be made in the water. This helicopter is not certified for ditching without floats and this section should not be construed as implying such certification.**

### 3-42. General

1. Ditching with Power - If ditching is unavoidable without other recourse, proceed as follows:

- a. Descend to low hovering altitude over water.
- b. Unlatch both doors.
- c. Exit passengers.
- d. Hover clear of passengers.
- e. Turn off battery and generator.
- f. Close throttle and complete hovering autorotation.
- g. As collective reaches full up position and helicopter settles into water, apply full right lateral cyclic.
- h. Exit helicopter when rotor stops.

### WARNING

**Clear helicopter as quickly as possible.**

2. Ditching without Power - If engine failure occurs over water, accomplish engine failure emergency procedure and proceed as follows:

- a. Unlatch doors.
- b. Land. Complete normal autorotational landing in water.
- c. As collective reaches full up position and helicopter settles in water, apply full lateral cyclic in direction helicopter tends to roll.
- d. Pilot and passengers exit helicopter when main rotor stops.

**WARNING**

**Clear helicopter as quickly as possible.**

## SECTION VIII. FLIGHT CONTROL MALFUNCTIONS

### 3-43. Cyclic Control Vibration Absorber Beam Failure

Failure of a cyclic control vibration absorber beam will result in a sudden increase in the 3/Rev vibration level felt in the cyclic control stick. In the event of a sudden increase of 3/Rev vibration in the cyclic controls, land as soon as practicable, shutdown the aircraft, and inspect the vibration absorber beams. Before continuation of flight, the failed portion of the beam and lanyard shall be removed from the aircraft. Continued operation of the aircraft after beam failure is approved; however, the cyclic control vibration levels will be significantly higher and the vibration absorber assembly should be repaired as soon as possible.

### 3-44. Cyclic Trim Failure

Failure of the cyclic trim control system will result in either inoperative trim or a trim runaway in one of the four primary directions (forward, aft, left or right). If the trim circuit breaker trips, it should be left out for the remainder of the flight. Depending upon the failure mode and the flight condition at the time of failure, the cyclic forces may be relatively light or they may be excessive. The pilot should evaluate the situation and determine if a precautionary landing is indicated or if the flight should be completed as planned. The pilot should be aware that the cyclic forces will change between cruise flight and approach and landing.

If the trim stops operating when the switch is engaged, the trim does not stop when the switch is released, or if the circuit breaker trips, the operator should:

1. Immediately stop using the trim and pull the TRIM circuit breaker to deactivate the circuit. Leave the circuit breaker out for the remainder of the flight.
2. If the pilot determines the flight can be continued safely, without use of the trim, flight may be continued to the next destination.

3. If the pilot has any safety concerns, a landing should be made as soon as practical.

a. If there is a significant reduction in the longitudinal control, the pilot should plan a landing at a shallow approach to an area where a run-on landing can be made.

b. If there is a significant reduction in the lateral cyclic control, it may be difficult or impossible to make turns to the right.

i. The pilot should plan a landing to an area where there is ample room to maneuver. The aircraft will fly in a left crab, and maintaining a straight course may be difficult.

ii. Perform an approach to a low hover; forward speed can be stopped, but there may be some sideward drift.

iii. Once forward speed is reduced in a low hover, the pilot can roll off the throttle and align the aircraft with the direction of motion using the pedals prior to touching down.

iv. If the pilot is having difficulty maintaining the approach course, the pilot should consider making a 360° turn to the left to line up on the final approach again.

v. Directional control is easier to maintain at airspeeds above 60 knots, but the pilot must plan to reduce forward speed prior to touchdown.

4. Ground the aircraft at the end of the flight. The aircraft should be grounded until the problem is resolved by a maintenance technician.

**INTENTIONALLY LEFT BLANK**



**CHAPTER 4. PERFORMANCE DATA**

**TABLE OF CONTENTS**

<u>SECTION</u>	<u>DESCRIPTION</u>	<u>PAGE</u>
	Table of Contents .....	4-1
Section I	Introduction .....	4-5
Paragraph 4-1	Purpose.....	4-5
4-2	General .....	4-5
4-3	Limits.....	4-6
4-4	Use of Charts .....	4-6
4-5	Specific Conditions.....	4-6
4-6	General Conditions .....	4-7
4-7	Performance Discrepancies .....	4-7
4-8	Temperature Conversion .....	4-8
4-9	Density Altitude .....	4-8
Section II	Airspeed Calibration.....	4-11
Paragraph 4-10	Description .....	4-11
4-11	Use of the Charts .....	4-11
4-11.1	Alternate Static Air Source .....	4-11
Section III	Torque Available.....	4-15
Paragraph 4-12	Description .....	4-15
4-13	Chart Uses .....	4-15
4-14	Conditions.....	4-15
4-15	Effect of Engine Bleed Air Usage .....	4-16
Section IV	Hover .....	4-19
Paragraph 4-16	Description .....	4-19
4-17	Chart Uses .....	4-19
4-18	Conditions.....	4-19
Section V	Power Assurance .....	4-23
Paragraph 4-19	Description .....	4-23
4-20	Chart Use.....	4-23
4-21	Conditions.....	4-24

**CHAPTER 4. PERFORMANCE DATA****TABLE OF CONTENTS**

<u>SECTION</u>		<u>DESCRIPTION</u>	<u>PAGE</u>
Section VI		Cruise .....	4-27
Paragraph	4-22	Description .....	4-27
	4-23	Chart Use .....	4-27
	4-24	Conditions .....	4-28
Section VII		Climb Performance.....	4-37
Paragraph	4-25	Description .....	4-37
	4-26	Chart Use .....	4-37
	4-27	Conditions .....	4-37
Section VIII		Autorotation.....	4-39
Paragraph	4-28	Height-Velocity Diagram .....	4-39
	4-29	Minimum Rate of Descent -	
		Power Off .....	4-39
	4-30	Maximum Glide Distance -	
		Power Off .....	4-39
	4-31	Rotor RPM Control - Power Off..	4-39
Section X		Noise.....	4-45
Paragraph	4-32	Noise.....	4-45

**LIST OF FIGURES**

<u>FIGURE NO.</u>	<u>DESCRIPTION</u>	<u>PAGE</u>
4-1	Temperature Conversion Chart.....	4-9
4-2	Density Altitude Chart.....	4-10
4-3	Airspeed Calibration.....	4-13
4-4	Maximum Torque Available .....	4-17
4-5	Deleted	
4-6	Hover Performance .....	4-21
4-7	Power Assurance .....	4-25
4-8	Cruise Performance-Sea Level .....	4-29

## CHAPTER 4. PERFORMANCE DATA

### LIST OF FIGURES

<u>FIGURE NO.</u>	<u>DESCRIPTION</u>	<u>PAGE</u>
4-9	Cruise Performance-3,000 Feet.....	4-31
4-10	Cruise Performance-6,000 Feet.....	4-33
4-11	Cruise Performance-9,000 Feet.....	4-35
4-12	Best Rate of Climb Speed.....	4-38
4-13	Height-Velocity Diagram .....	4-40
4-14	Autorotative Descent Schedule .....	4-41
4-15	Maximum Glide Distance.....	4-42
4-16	Rate of Decent vs. Rotor RPM .....	4-43

### LIST OF TABLES

<u>TABLE NO.</u>	<u>DESCRIPTION</u>	<u>PAGE</u>
4-0	Alternate Static Air Source Correction .	4-12
4-1	Effect of Engine Bleed Air Usage .....	4-16

**INTENTIONALLY LEFT BLANK**

## CHAPTER 4

### PERFORMANCE DATA

#### SECTION I. INTRODUCTION

##### 4-1. Purpose

1. The purpose of this chapter is to provide the best available data for the 480B helicopter. Regular use of this information will enable you to obtain maximum safe utilization from your aircraft. Although maximum performance is not always required, regular use of this chapter is recommended for the following reasons:

a. Knowledge of the aircraft performance margins will allow you to make better decisions when unexpected conditions or alternate missions are encountered.

b. Situations requiring maximum performance will be readily recognized.

c. Familiarity with the data will allow performance to be computed more easily and rapidly.

d. Experience will be gained in accurately estimating the effects of variables for which data are not presented.

#### NOTE

**The information provided in this chapter is primarily intended for flight planning and is most useful when planning operations in unfamiliar areas or at extreme conditions.**

##### 4-2. General

1. The data presented covers the maximum range of conditions and performance that can reasonably be

expected. In each area of performance, the effects of altitude, temperature, gross weight, and other parameters relating to that phase of flight are presented. In addition to the presented data, your judgment and experience will be necessary to accurately obtain performance under a given set of circumstances. The conditions for the data are listed under the title of each chart. The effects of different conditions are discussed in the text accompanying each phase of performance. Where practical, data are presented at conservative conditions. However, NO GENERAL CONSERVATISM HAS BEEN APPLIED. All performance data presented are within the applicable limits of the aircraft.

### **4-3. Limits**

1. Applicable limits are shown on the charts as darker lines. Performance generally deteriorates rapidly beyond limits. If limits are exceeded, minimize the amount and time. Enter the maximum value and time above limits in the aircraft log book so proper maintenance action can be taken.

### **4-4. Use of Charts**

1. The first page of each section describes the chart(s) and explains the usage. Depending on the complexity of the chart, the primary use of each chart is given in an example and a line with arrows is provided to help you follow the route through the chart. The use of a straight edge (ruler, etc.) and a hard fine point pencil is recommended to avoid cumulative errors. Other uses of each chart are explained in the text accompanying each set of performance charts.

### **4-5. Specific Conditions**

1. The data are presented only for specific conditions listed under the title for each chart. Variables for which data are not presented, but which may effect that phase of performance, are discussed in the text. Where data are available or reasonable estimates can be made, the

amount that each variable effects the performance will be given.

#### **4-6. General Conditions**

1. In addition to the specific conditions, the following general conditions are applicable to the performance data:

a. Rigging. All airframe and engine controls are assumed to be rigged within allowable tolerances

b. Pilot Technique. Normal pilot technique is assumed. Control movements should be smooth and continuous.

c. Aircraft Variation. Variations in performance between individual aircraft are known to exist, however, they are considered to be small and cannot be individually accounted for.

d. Instrument Variation. The data shown in the performance charts do not account for instrument inaccuracies or malfunctions. The data presumes that all instruments, indicators, and transducers are maintained in proper working condition and are properly maintained in calibration.

#### **4-7. Performance Discrepancies**

1. Regular use of this chapter will allow you to monitor instruments and other aircraft systems for malfunction by comparing actual performance with planned performance. Knowledge will also be gained concerning the effects of variables for which data are not provided, thereby increasing the accuracy of the performance predictions.

#### 4-8. Temperature Conversion

1. Refer to Figure 4-1 for temperature conversion from degrees F to C or degrees C to F.
2. Use of chart:
  - a. To determine degrees F to C, enter chart at left with degrees F.
  - b. Move across the chart to the intercept line.
  - c. Move down the chart to determine degrees C.
  - d. Reverse the procedure to determine degrees C to F.

#### 4-9. Density Altitude

1. The Density Altitude Chart (Figure 4-2) allows a quick estimation of the density altitude when the pressure altitude and OAT are known.
2. Use of chart:
  - a. Enter bottom of the chart with the known or estimated OAT.
  - b. Move up the chart to the known pressure altitude line. Set the altimeter to 29.92 IN. HG. to determine the pressure altitude.
  - c. Move to the left and determine the density altitude.



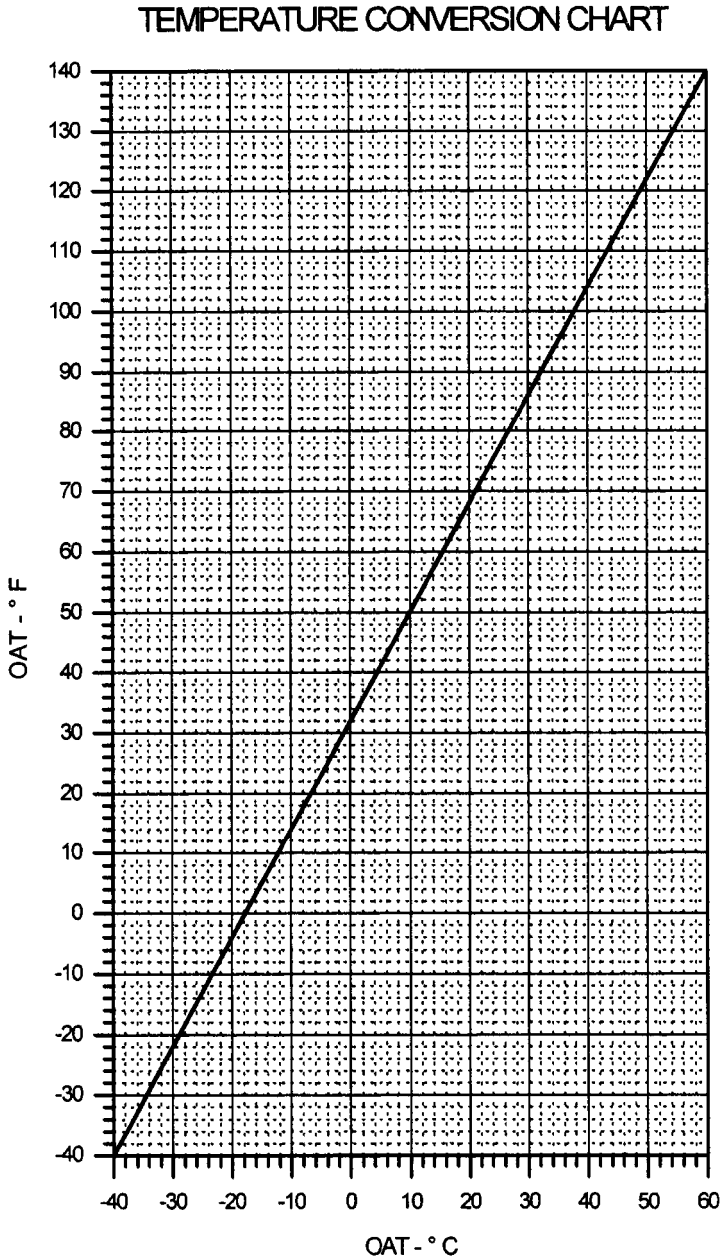

Figure 4-1. Temperature Conversion Chart

### DENSITY ALTITUDE CHART

SET ALTIMETER TO 29.92 IN. HG.  
WHEN READING PRESSURE ALTITUDE

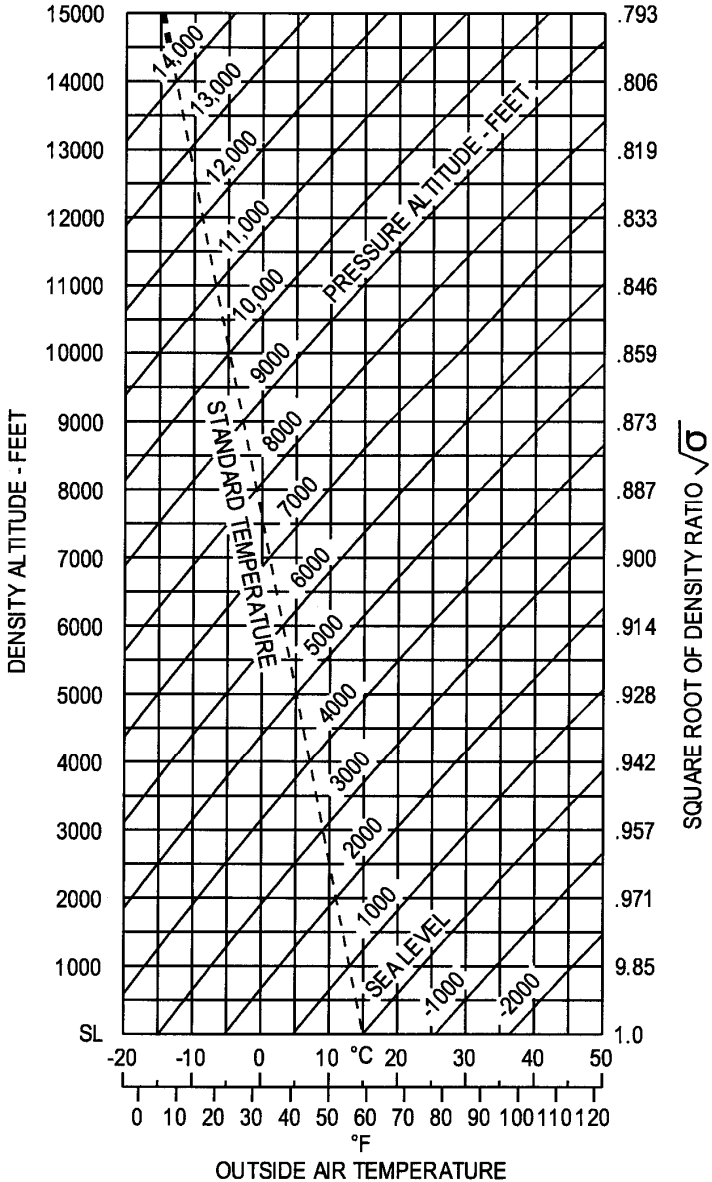

Figure 4-2. Density Altitude Chart

## SECTION II. AIRSPEED CALIBRATION

### 4-10. Description

1. Airspeed Calibration charts are provided for two different pitot tube locations. Sheet 1 of Figure 4-3 presents the airspeed correction for the standard "chin mounted" pitot tube. Sheet 2 of Figure 4-3 presents the airspeed correction for the optional "nose mounted" pitot tube. The Airspeed Calibration charts show the correction to be added to the indicated cockpit airspeed to obtain calibration airspeed. The charts show corrected curves for descent/autorotation, level flight and climb.

### 4-11. Use of the Charts

1. The primary use of the charts is indicated by the examples.

2. In general it is not essential to know the correction to the indicated airspeed unless the pilot desires to achieve very precise performance from the helicopter. The corrections are sufficiently small that one or two knot variation between the indicated airspeed and the actual calibrated airspeed will have an insignificant effect on the aircraft performance.

3. To determine the correction to be added, the pilot must know the airspeed of interest and the maneuver to be flown. By entering the chart from the bottom, at the airspeed, and moving vertically up to the curve for the intended maneuver, then left to the scale on the left side of the chart, the correction to be added to the cockpit indicated airspeed can be obtained.

#### 4-11.1 Alternate Static Air Source

1. The aircraft can be equipped with an optional alternate static air source which allows the pilot to use the interior of the cabin as a static air reference. Due to inherent inaccuracies, this system should only be used when necessary, for example if icing conditions are encountered and cannot be avoided.

2. With the cabin windows closed, the airspeed indicator will read approximately 5 knots high at slow airspeeds (40 KIAS) and 10 knots high at high airspeeds (115 KIAS). The altimeter error will range from almost zero at low airspeeds to 100 feet high at high airspeeds. (See Table 4-0.)

3. With the windows open, the errors range from approximately 8 knots high and 50 feet high at low airspeeds to 15 knots high and 150 feet high at high airspeeds.

4. Heater and defroster operation does not affect these errors.

5. Except as specifically mentioned, all data in this manual is based on the standard static air system.

**Table 4-0. Alternate Static Air Source Correction**

ALTERNATE STATIC SOURCE ALTIMETER CORRECTION		
INDICATED AIRSPEED  (KNOTS)	ADD TO ALTIMETER READING	
	WINDOWS CLOSED (FEET)	WINDOWS OPEN (FEET)
40	+5	0
50	+5	-15
60	-10	-35
70	-25	-55
80	-40	-75
90	-60	-95
100	-75	-115
110	-95	-140
120	-115	-170

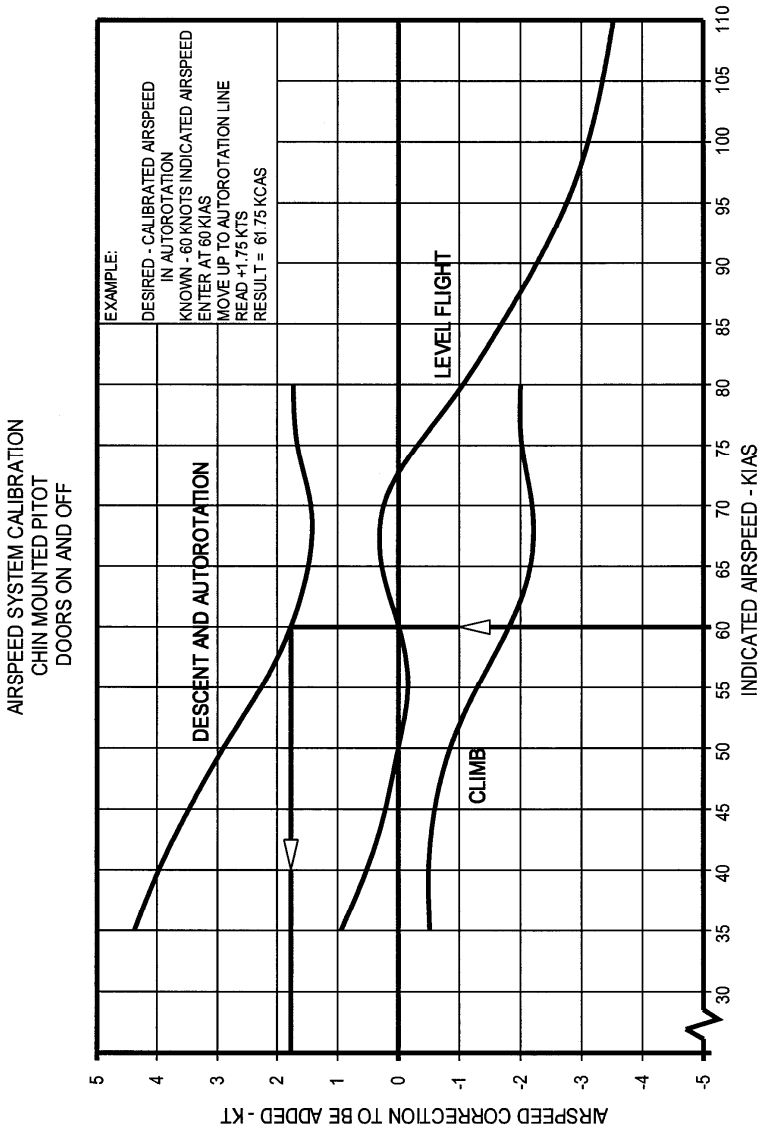

Figure 4-3. Airspeed Calibration

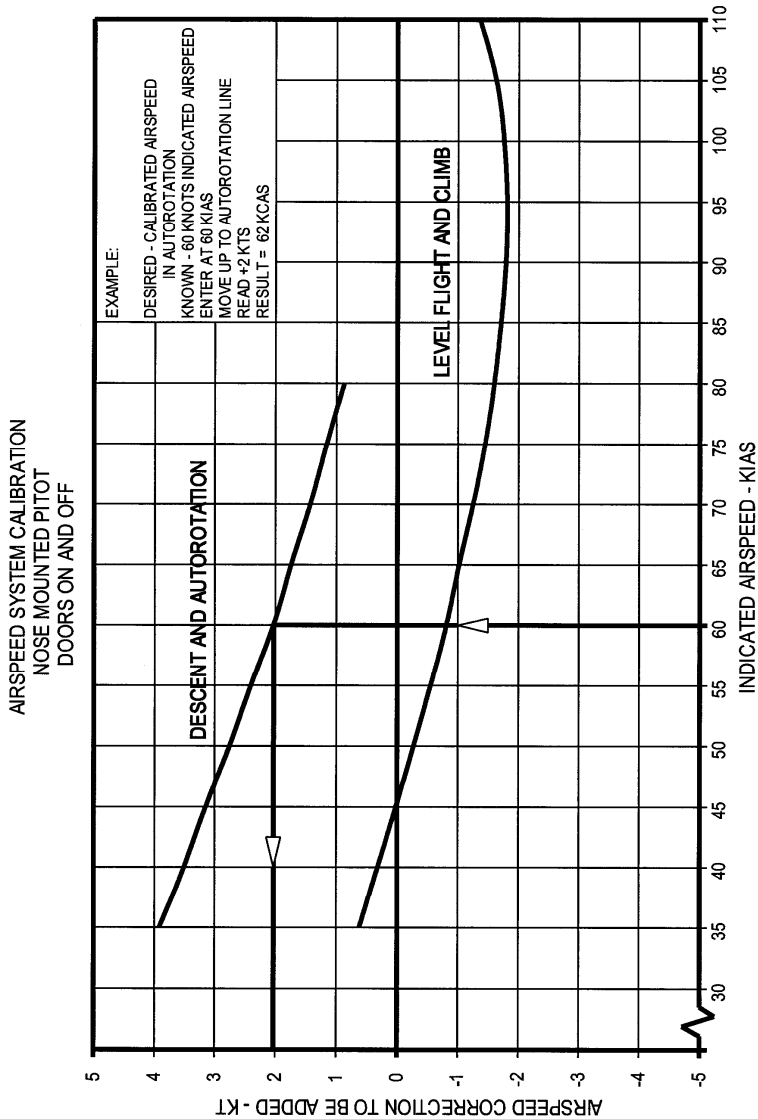

Figure 4-3. Airspeed Calibration

## SECTION III. TORQUE AVAILABLE

### 4-12. Description

1. The torque available chart shows the effects of altitude and temperature on engine power available.

### 4-13. Chart Uses

1. Figure 4-4 shows the maximum torque available as limited by either the transmission or the engine. The primary use of the chart is to provide the pilot information on the maximum power available either as a function of the helicopter limits or the flight conditions. Since both pressure altitude and outside air temperature effect engine power it is necessary that the pilot enter the chart with both values. By entering the chart at the left side at the known pressure altitude and moving right to the known OAT, then straight down to the bottom, available torque is obtained.

---

### CAUTION

---

**The engine power output can exceed the transmission structural limit (72 PSI) under certain conditions. Where the torque obtained from this chart is less than the transmission limit, the engine TOT will be at the 810°C (1490°F) limit at the torque obtained. It is the responsibility of the pilot to monitor and observe both the torque (transmission) and TOT (engine) limits during all operations where maximum power is required.**

### 4-14. Conditions

1. The maximum torque available chart is based upon engine speed of 103% N<sub>2</sub> and main rotor speed of 364 RPM with Jet A fuel. The use of aviation gasoline will not

influence engine power. Fuel grades Jet A, A-1, JP-4 and JP-5 will all yield the same nautical miles per pound of fuel. The heavier density of the JP-5 and Jet A type fuels will only result in increased fuel weight per gallon. Because JP-4, JP-5, and Jet A have the same energy value per pound, JP-5 and Jet A fuel will increase range by approximately 3-4 percent per gallon of fuel over JP-4.

#### 4-15. Effect of Engine Bleed Air Usage

1. Operation of the Engine Anti-Ice, Scav-Air, and/or Bleed Air Heater/Defroster results in higher TOT,  $N_1$  speed and fuel flow to achieve the same torque setting. Because the engine power is torque limited in the 480B, torque will normally be the limiting consideration. However, in some conditions, TOT or  $N_1$  may approach operational limits thus limiting the power available. Table 4-1 lists the approximate effect of using Engine Anti-Ice, Scav-Air, and/or Bleed Air Heater/Defroster on engine performance. This table is based on sea level standard day conditions.

**Table 4-1. Effect of Engine Bleed Air Usage**

TYPE OF OPERATION	APPROX. EFFECT ON PERFORMANCE (@ power levels above 78.5% $N_1$ )
Constant TOT (810°C) (Takeoff Power)	37 SHP decrease, 1.82% $N_1$ decrease
Constant $N_1$ of 101%	13 SHP decrease, 38°C TOT increase
Constant SHP and constant collective	0.88% $N_1$ increase, 56°C TOT increase and up to 20% increase in fuel consumption



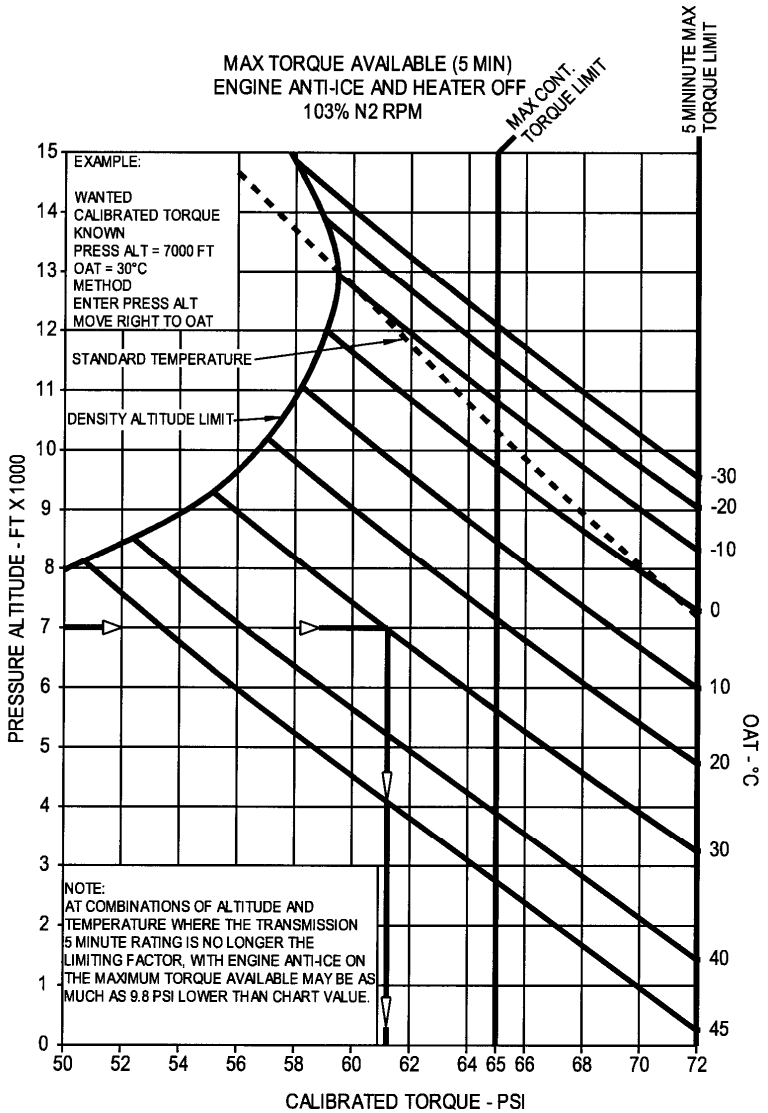

Figure 4-4. Maximum Torque Available (5 Minute Limit)

**INTENTIONALLY LEFT BLANK**

## SECTION IV. HOVER

### 4-16. Description

1. The Hover Performance chart (Figure 4-6) shows weight limits, hover ceiling, and the torque required to hover at various pressure altitudes, ambient temperatures (OAT), gross weights, and skid heights.

### 4-17. Chart Uses

1. The primary use of this chart is illustrated by the example on the chart. It is necessary to use both the hover chart and the maximum torque available chart to determine the power margin for the intended operation. In general, to determine the hover ceiling or the torque required to hover it is necessary to know the pressure altitude, OAT, gross weight, and the desired skid height.

### 4-18. Conditions

1. The hover performance chart is based upon engine speed of 103% N<sub>2</sub> and main rotor speed of 372 RPM, grade Jet A fuel, and a limiting engine TOT of 737 °C (1360 °F), the engine maximum continuous TOT limit.

#### NOTE

**The difference between the torque required to hover at the desired skid height, as determined from this chart, and the transmission structural limit (72 PSI), or the maximum torque available as determined from Figure 4-4, will be the power reserve available for the intended flight operation.**

**INTENTIONALLY LEFT BLANK**

### Hover Performance

Calm Wind  
103% N<sub>2</sub>  
372 Rotor RPM  
All Bleed Air Off

See Limitations Section for Altitude and OAT Limits

#### EXAMPLE

5000 FT Pressure Alt.  
10°C  
2,750 LB GW  
  
56 PSI HIGE  
64 PSI HOGE

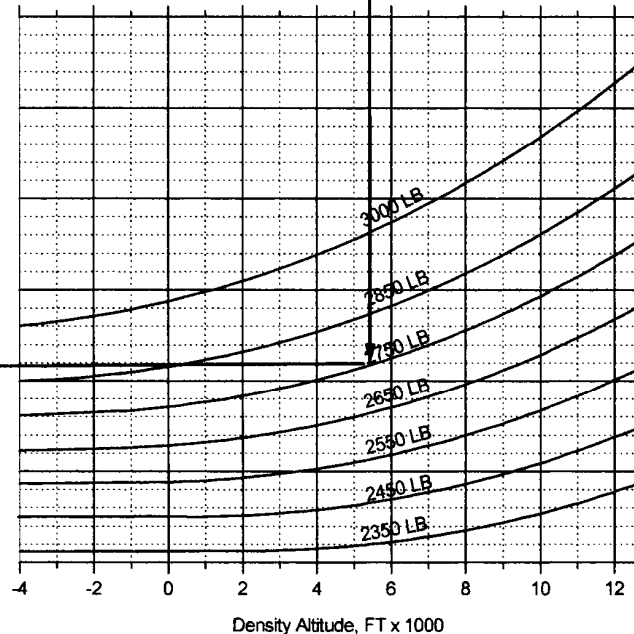
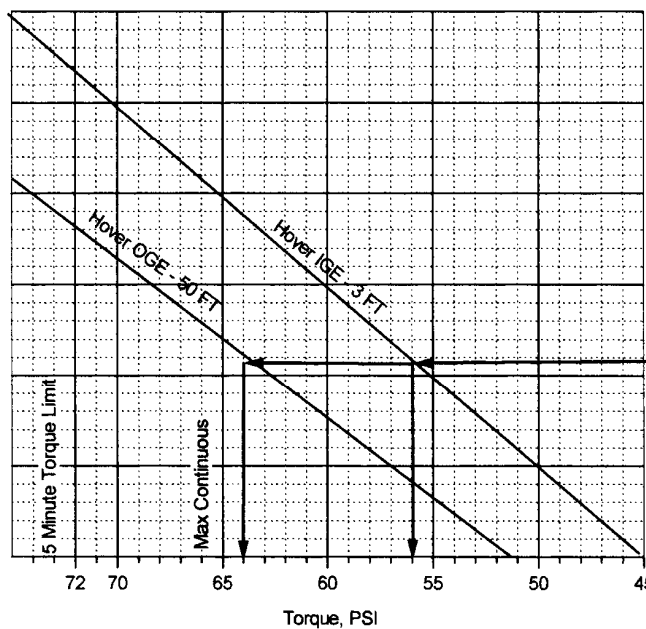
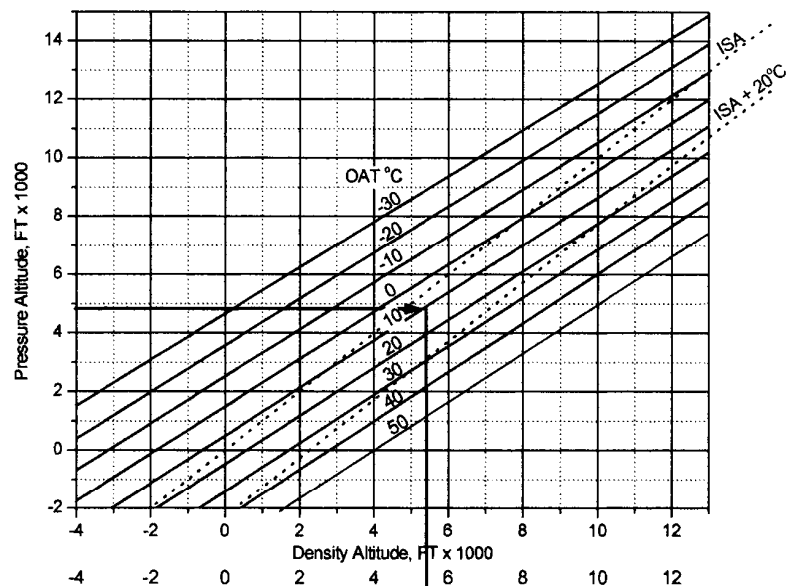

Figure 4-6. Hover Performance

## SECTION V. POWER ASSURANCE

### 4-19. Description

1. The Power Assurance Chart (Figure 4-7) provides the pilot a method for assuring that the installed engine will provide the necessary power required to achieve the performance presented in this manual.

### 4-20. Chart Use

1. The primary use of this chart is illustrated by an example on the chart. The main consideration for the pilot is to ensure that the installed engine will deliver the power necessary for the helicopter to achieve the calculated performance. The engine power assurance chart provides a means for the pilot to double check the installed engine power prior to takeoff. This chart is intended to be used in the helicopter and, although the calculated hover torque, altitude, and OAT can be used during pre-flight planning to determine the expected TOT at a hover, the chart should be used to plot the actual data taken at a hover just prior to takeoff as the best means to determine that the calculated performance can be achieved. The pilot should come to a stabilized hover, record the pressure altitude, OAT, torque and TOT, then land and plot the actual data on this power assurance chart. If the actual TOT is less than or equal to the TOT determined from this chart then the helicopter can be expected to achieve the pre-flight calculated performance for the flight. If the actual TOT is above the TOT determined from the chart, the pilot should use his or her best judgment in deciding whether or not to continue the flight. The discrepancy could be a result of gradual engine deterioration, a dirty compressor, improperly rigged bleed air system, FOD, or inaccuracies in the engine instruments. The most common solutions include inspecting the bleed air system and conducting a compressor wash or rinse. The discrepancy should be brought to the attention of maintenance personnel.

#### 4-21. Conditions

1. The conditions for this chart are 103% N<sub>2</sub> engine RPM and 372 rotor RPM at a stable hover. The skid height and wind conditions may have a slight effect, but since this is just a check of torque versus TOT at the ambient conditions present at takeoff the effect should be minimal.

#### NOTE

**Because turbine engines do not completely stabilize for a few minutes after power is set, if the initial TOT at a hover fails to meet the power assurance chart criteria, it may be necessary to repeat the test by hovering for at least two minutes before retaking the data to confirm the engine performance.**

ENGINE POWER ASSURANCE CHART  
103% N2 RPM - ALL BLEED AIR OFF

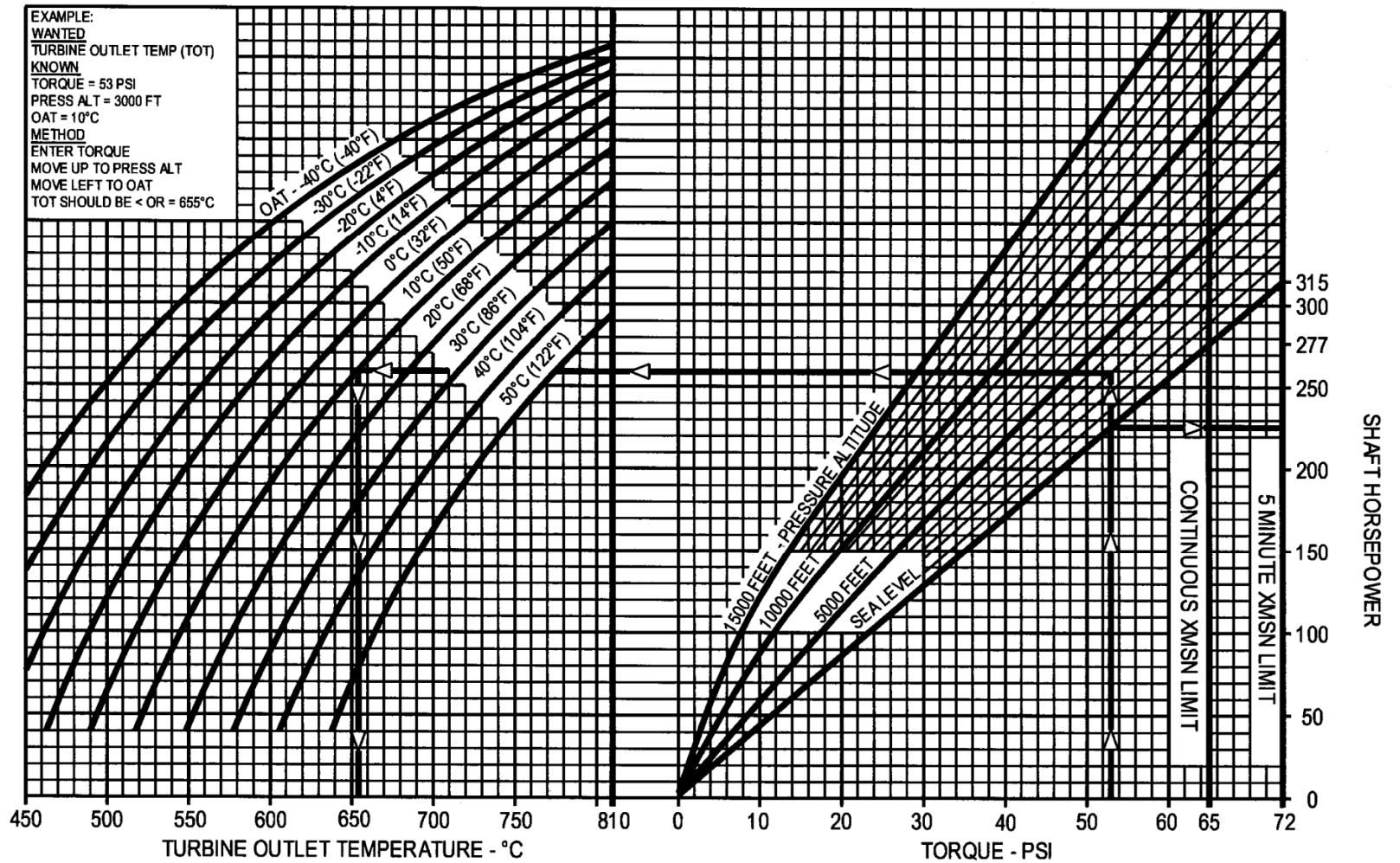

Figure 4-7. Power Assurance



## SECTION VI. CRUISE

### 4-22. Description

1. The Cruise Performance charts (Figure 4-8 through 4-11) show the torque pressure and fuel flow required for level flight at the various pressure altitudes, airspeeds, and gross weights.

### 4-23. Chart Use

1. The first step for chart use is to select the proper chart, based upon the pressure altitude. Normally, sufficient accuracy can be obtained by selecting the chart nearest to the planned cruising altitude, or the next higher altitude. If greater accuracy is required, interpolation between altitudes will be required. You may enter the charts on any side, TAS, Torque Pressure, or Fuel Flow, and then move vertically or horizontally to the Gross Weight, then to the other parameters. Maximum performance conditions are determined by entering the chart where the maximum range or maximum endurance and rate of climb lines intersect the appropriate gross weight; then read airspeed, fuel flow, and torque pressure. For conservatism, use the gross weight at the beginning of the flight. The following parameters contained in each chart are further explained as follows:

a. Airspeed. True airspeed is shown at the bottom of each chart.

b. Torque (PSI). Since pressure altitude and temperature are fixed for each chart, torque varies according to gross weight and airspeed.

c. Fuel Flow. Fuel flow is provided as a separate chart. All fuel flow information is presented with particle separator, engine anti-ice, heater and defroster off.

d. Maximum Range. The maximum range lines indicate the combinations of weight and airspeed that will produce the greatest flight range per gallon of fuel under zero wind conditions.

**NOTE**

**$V_{NE}$  is not shown on these charts because it varies with OAT and takeoff C.G. See Chapter 1 for  $V_{NE}$  limitations. Where  $V_{NE}$  is less than the airspeed indicated for maximum range, maximum range will be obtained at  $V_{NE}$ .**

e. Maximum Endurance and Maximum Rate of Climb. The maximum endurance lines indicate the airspeed for minimum torque required to maintain level flight for each gross weight, OAT, and pressure altitude. Since minimum torque will provide minimum fuel flow, maximum flight endurance will be obtained at the airspeeds indicated. Maximum rate of climb will also occur at this airspeed as it provides the greatest excess torque.

**4-24. Conditions**

1. The cruise charts are based upon operation at 103% engine  $N_2$  RPM, engine anti-ice, particle separator, defroster, and heater off.

**NOTE**

**At constant speed and shaft horsepower, turning engine anti-ice on may increase fuel flow by 20%, thus decreasing overall range and time aloft by an equal amount.**

**Cruise Performance**  
**Sea Level Pressure Altitude - Standard Temperature**  
 $N_2 = 103\%$ , All Bleed Air Off  
See Figure 1-3 for  $V_{NE}$  Limitations

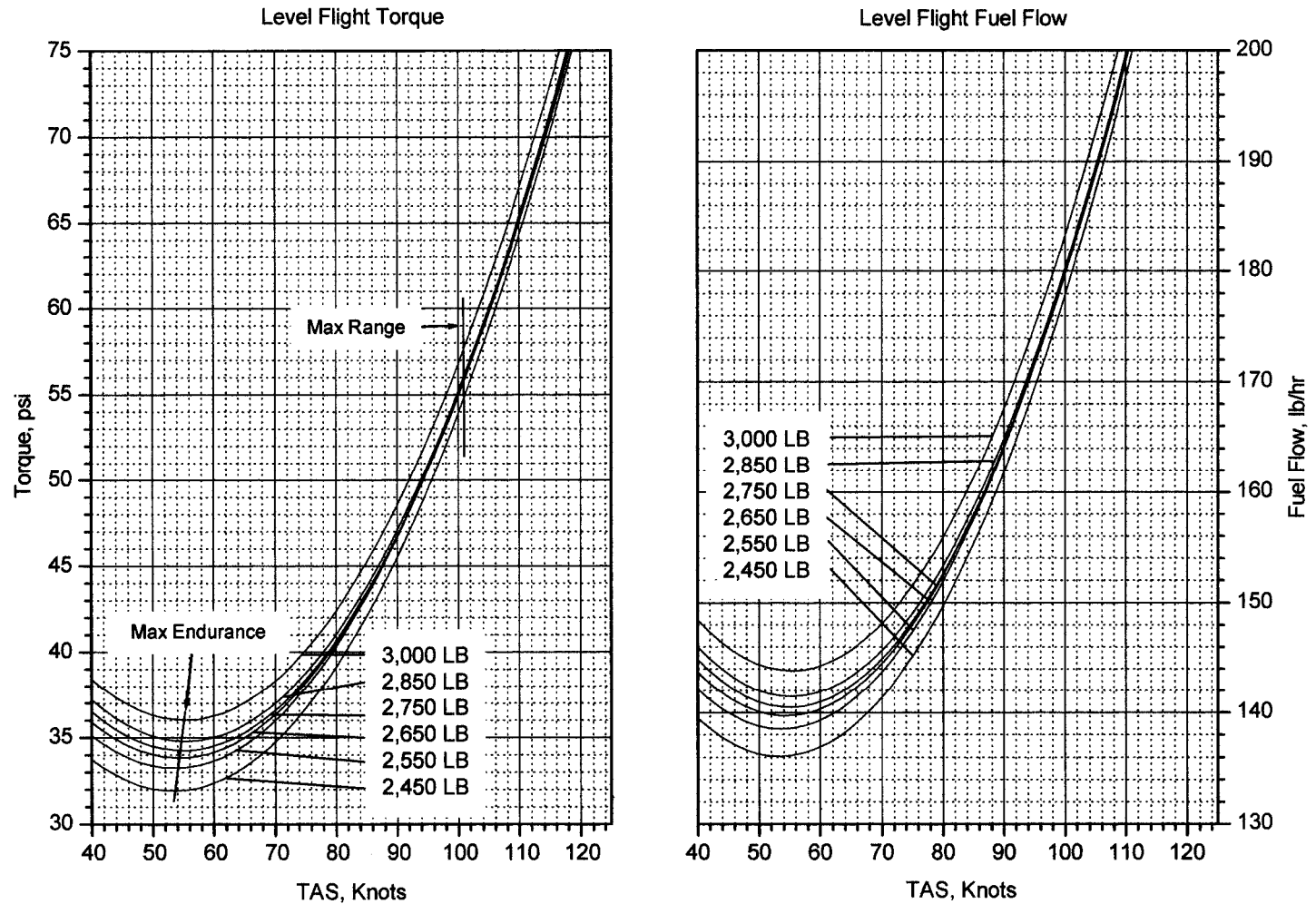

Figure 4-8. Cruise Performance - Sea Level

**Cruise Performance**  
**3000 Feet Pressure Altitude - Standard Temperature**  
 **$N_2 = 103\%$ , All Bleed Air Off**  
**See Figure 1-3 for  $V_{NE}$  Limitations**

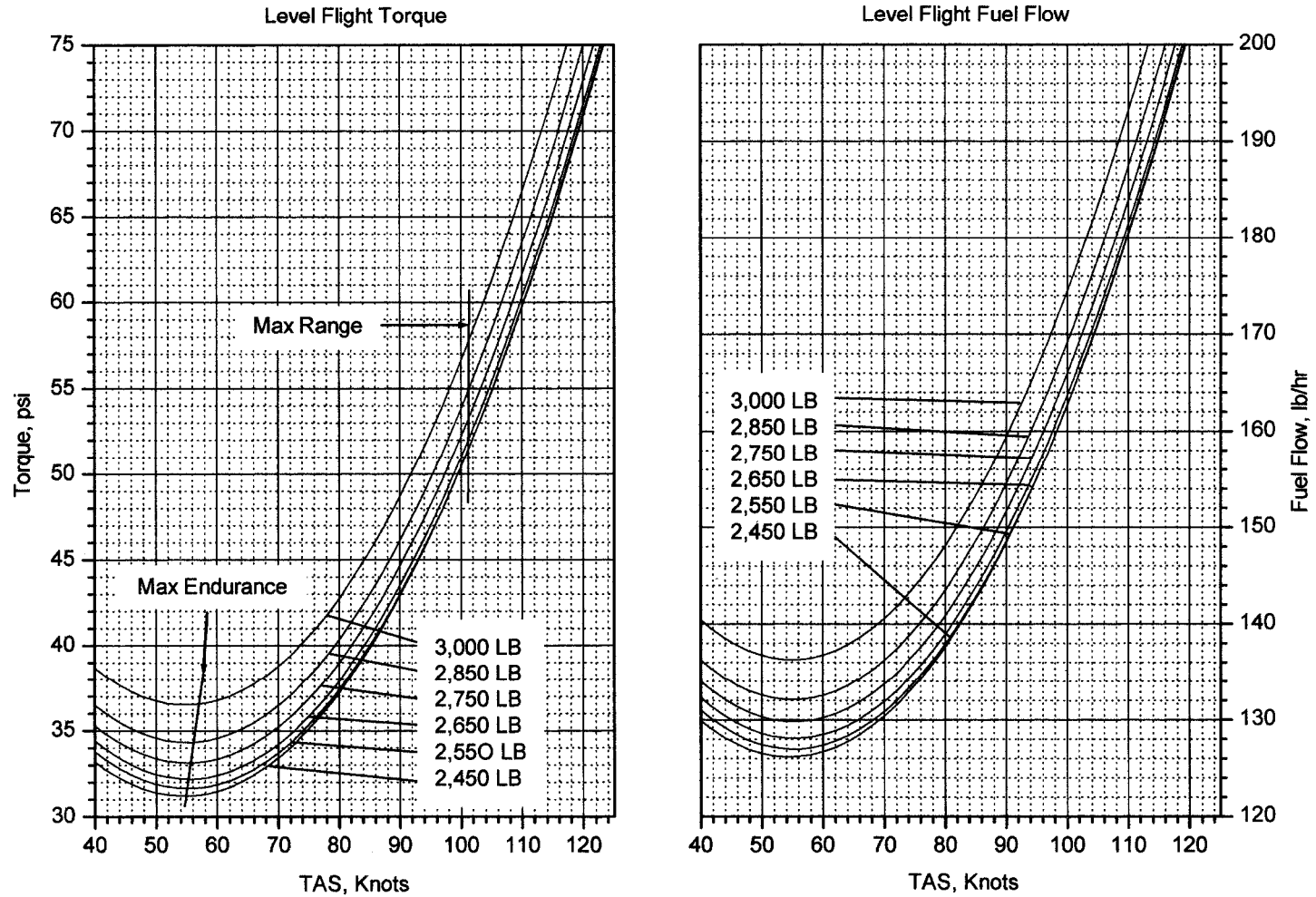

Figure 4-9. Cruise Performance - 3000 Feet

**Cruise Performance**  
**6000 Feet Pressure Altitude - Standard Temperature**  
**N<sub>2</sub> = 103%, All Bleed Air Off**  
**See Figure 1-3 for V<sub>NE</sub> Limitations**

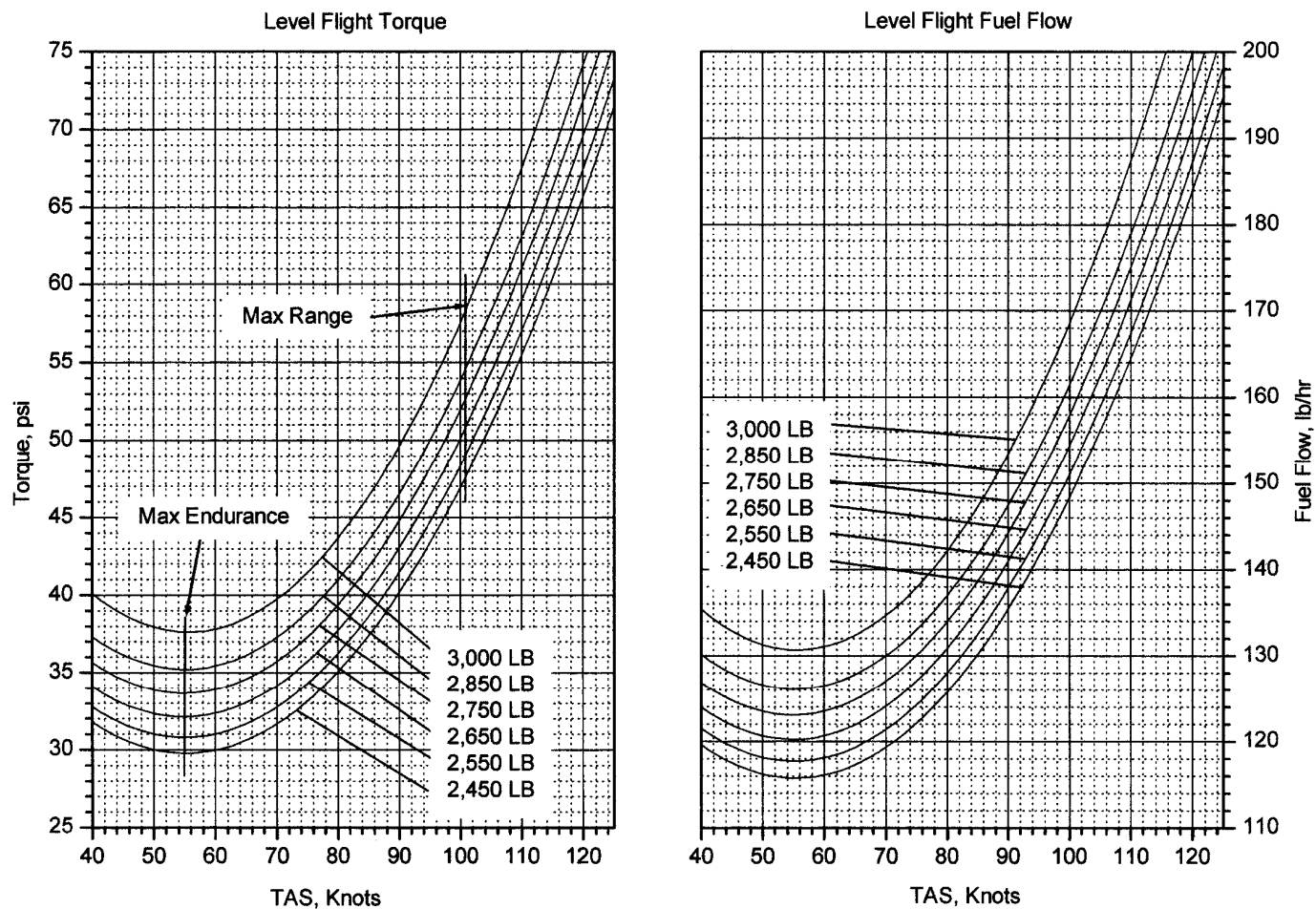

Figure 4-10. Cruise Performance - 6000 Feet

**Cruise Performance**  
**9000 Feet Pressure Altitude - Standard Temperature**  
 **$N_2 = 103\%$ , All Bleed Air Off**  
**See Figure 1-3 for  $V_{NE}$  Limitations**

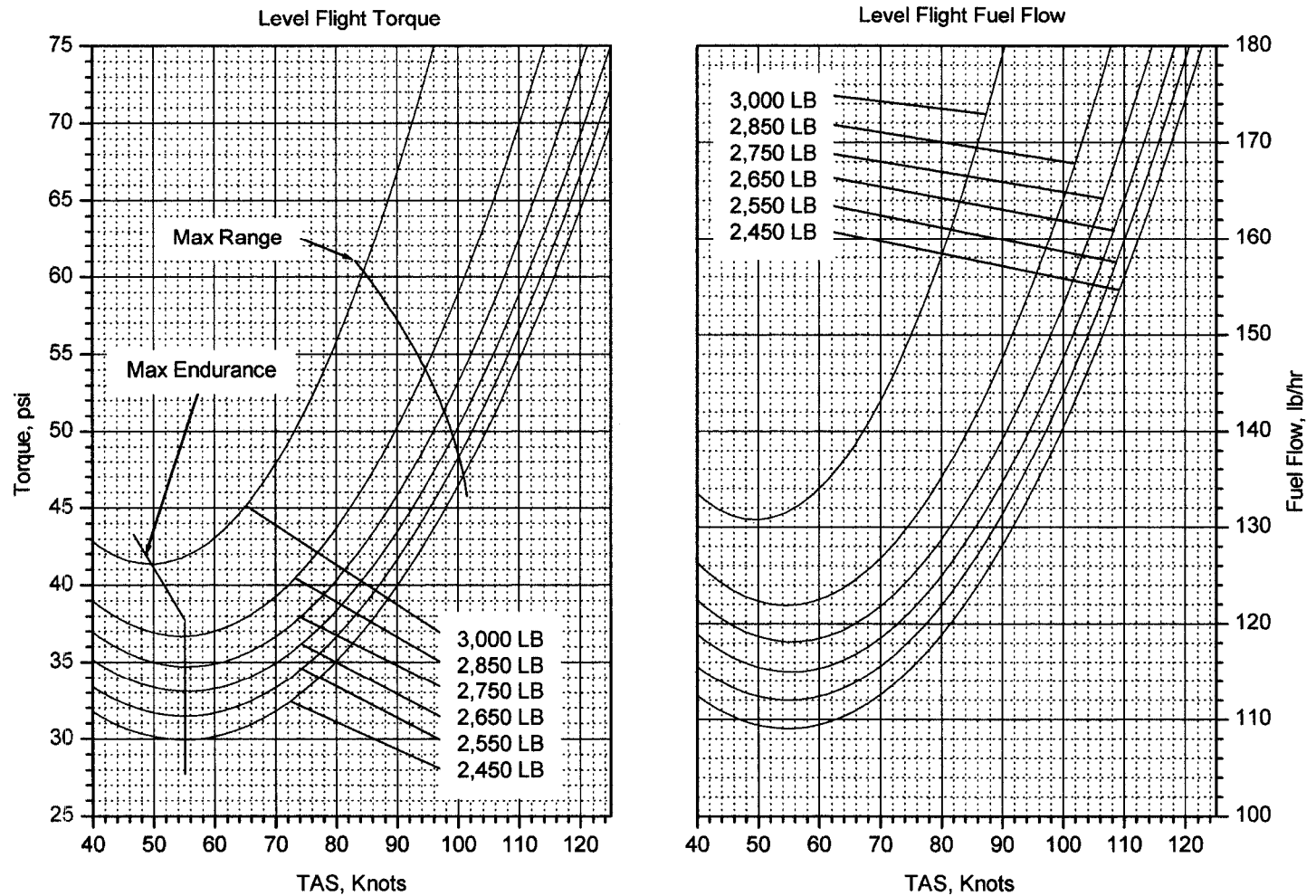

Figure 4-11. Cruise Performance - 9000 Feet

## **SECTION VII. CLIMB PERFORMANCE**

### **4-25. Description**

1. The Best Rate of Climb Speed chart (Figure 4-12) shows the optimum climb speed (calibrated airspeed versus density altitude) for any given density altitude.

### **4-26. Chart Use**

1. Enter density altitude on the left side of the chart.
2. Move across to the intercept line.
3. Move down to determine Best Rate of Climb Speed (KCAS).

### **4-27. Conditions**

1. This chart is based on maximum continuous power, 103%  $N_2$  and 372 rotor RPM in a no-wind condition. No data is shown for the 5 minute power rating as that is considered a contingency rating for initial obstacle clearance takeoff.

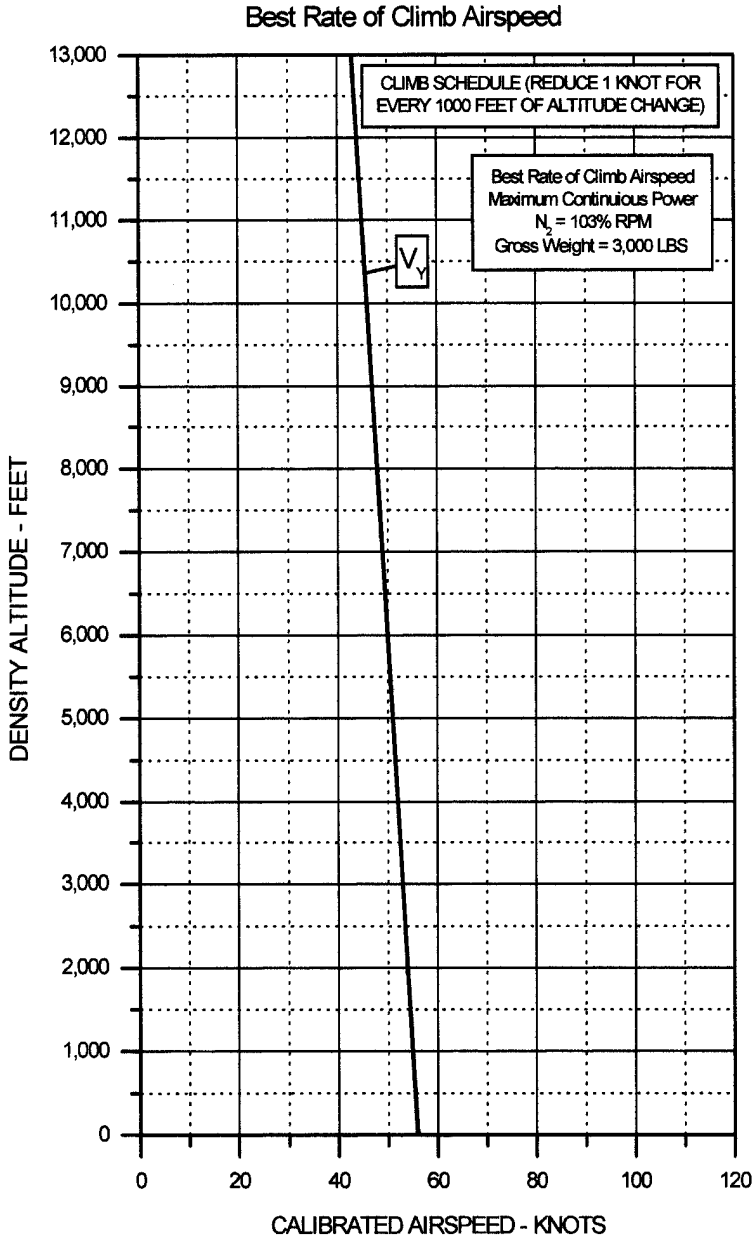

Figure 4-12. Best Rate of Climb Speed



## SECTION VIII. AUTOROTATION

### 4-28. Height-Velocity Diagram

1. The Height-Velocity Diagram is shown in Figure 4-13. Each curve was developed at the weight and altitude conditions specified.

### 4-29. Minimum Rate of Descent - Power Off

1. Below 6,000 feet density altitude, the minimum rate of descent is attained at an indicated airspeed of approximately 50 KIAS and 334 rotor RPM. Above 6,000 density altitude the airspeed for minimum rate of descent decreases 2 knots per 1,000 feet (See Figure 4-16). At airspeeds below 50 KIAS the rate of descent increases and glide distance decreases.

### 4-30. Maximum Glide Distance - Power Off

1. The maximum glide distance is attained at an indicated airspeed of approximately 80 KIAS and 334 rotor RPM at sea level. The airspeed decreases 2 knots for each 1,000 feet density altitude above sea level (see Figure 4-16). Refer to Figure 4-17, Maximum Glide Distance in Autorotation, for glide distance in autorotation.

### 4-31. Rotor RPM Control - Power Off

1. Rate of descent will increase as the rotor RPM increases from 334 RPM. Refer to Figure 4-18, Variation of Rate of Descent with Rotor RPM in Autorotation.

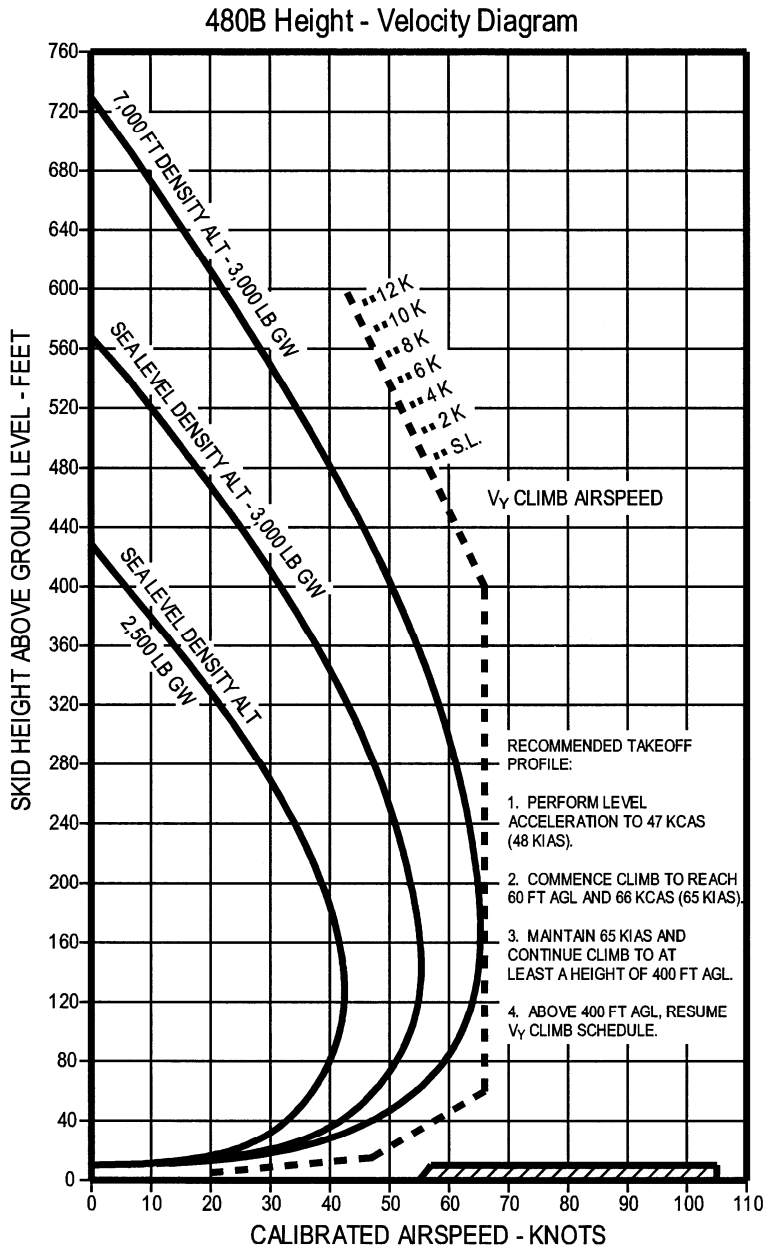

Figure 4-13. Height - Velocity Diagram

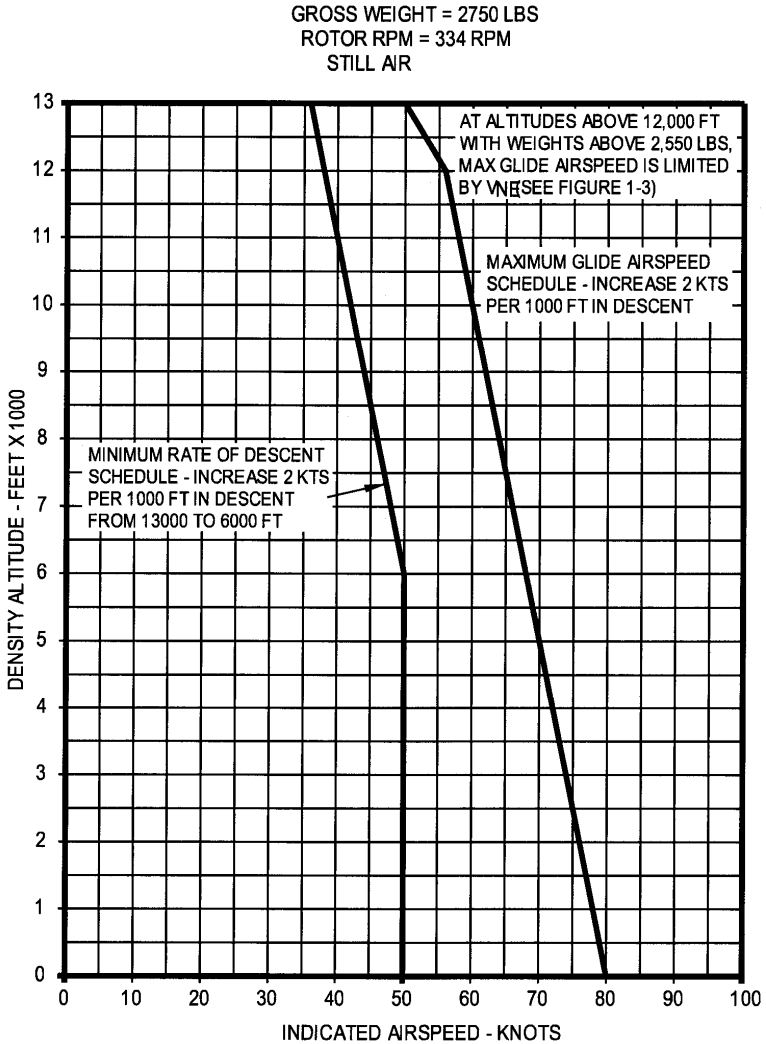

Figure 4-14. Autorotative Decent Schedule

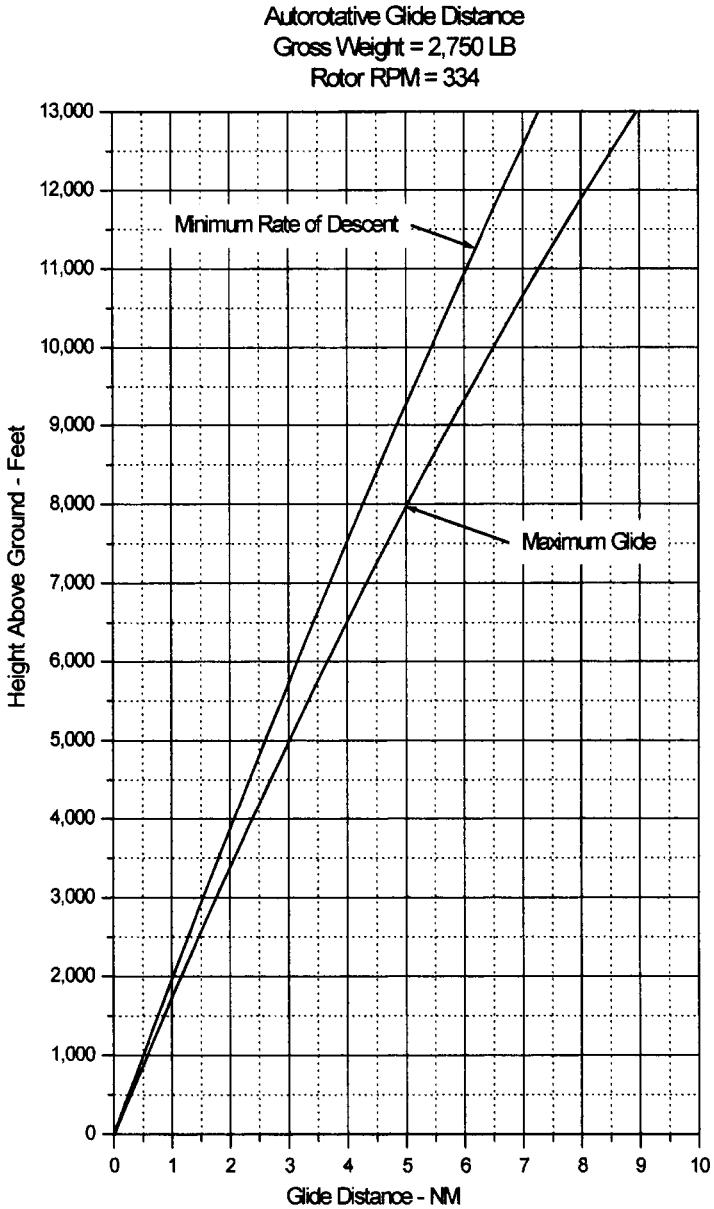

Figure 4-15. Maximum Glide Distance (Autorotation)

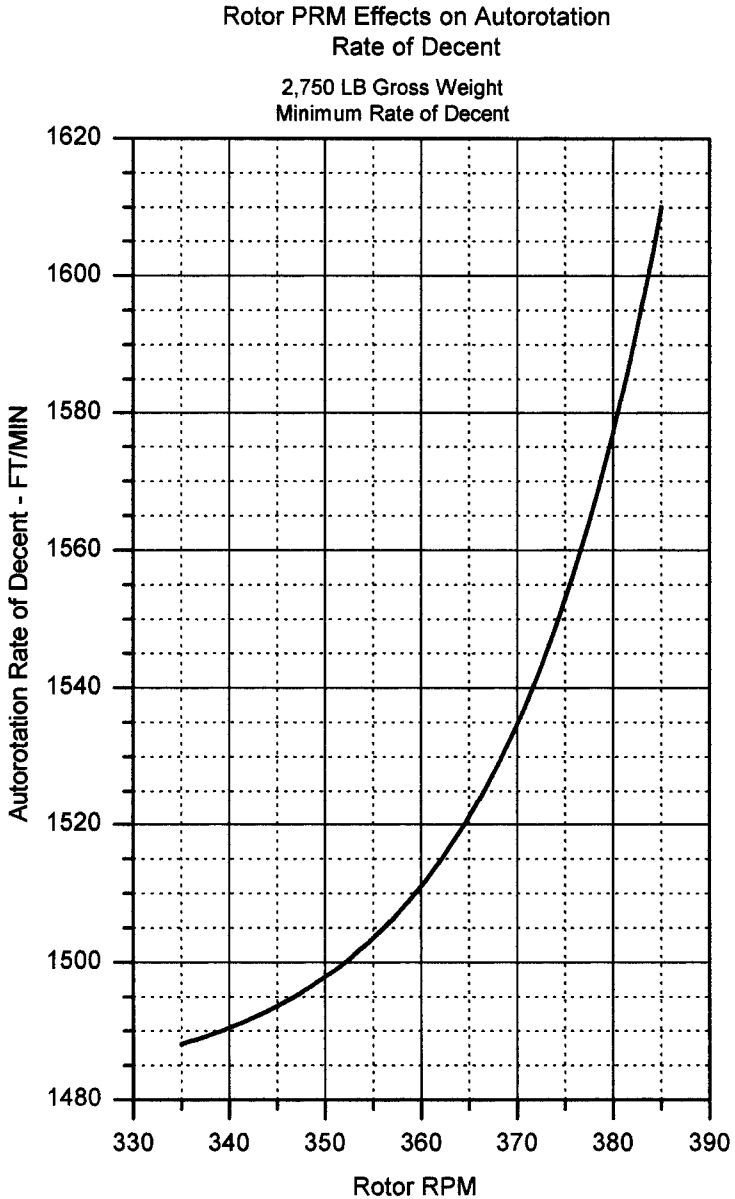

Figure 4-16. Rate of Decent vs. Rotor RPM (Autorotation)

**INTENTIONALLY LEFT BLANK**

## **SECTION IX. NOISE**

### **4-32. Noise**

1. In accordance with Appendix J of FAR 36, the fly-over noise level at a reference airspeed of 93.5 KTAS is 83.7 dBA. No determination has been made by the Federal Aviation Administration that the noise levels of this aircraft are or should be acceptable or unacceptable for operation at, into, or out of any airport.

**INTENTIONALLY LEFT BLANK**



## CHAPTER 5. OPTIONAL EQUIPMENT SUPPLEMENTS

### TABLE OF CONTENTS

<u>SUPPLEMENT</u>	<u>DESCRIPTION</u>	<u>PAGE</u>
Supplement 1	Cargo Hook.....	5-1-1
Supplement 2	Snow Shoes .....	5-2-1
Supplement 3	External Fuel Filter .....	5-3-1
Supplement 4	Baggage Box Extension .....	5-4-1
Supplement 5	Camera Door.....	5-5-1
Supplement 6	Emergency Floats.....	5-6-1
Supplement 7	Air Conditioning.....	5-7-1
Supplement 8	Nose Positioned Camera Mount.....	5-8-1
Supplement 9	Searchlight .....	5-9-1
Supplement 10	Chelton Flight Systems EFIS.....	5-10-1

**INTENTIONALLY LEFT BLANK**

**CHAPTER 5**

**SUPPLEMENT 1**

**CARGO HOOK**

**TABLE OF CONTENTS**

<u>SECTION</u>		<u>DESCRIPTION</u>	<u>PAGE</u>
		Table of Contents .....	5-1-1
Section I		General .....	5-1-3
Paragraph	5-1-1	Introduction .....	5-1-3
	5-1-2	Description .....	5-1-3
Section II		Operating Limitations.....	5-1-4
Paragraph	5-1-3	Type of Operation .....	5-1-4
	5-1-4	Weight.....	5-1-4
	5-1-5	Center of Gravity Limitations...	5-1-4
	5-1-6	Airspeed Limitations.....	5-1-4
	5-1-7	Altitude Limitations.....	5-1-5
	5-1-8	Rotor Limitations .....	5-1-5
	5-1-9	Engine and Transmission .....	5-1-5
	5-1-10	Placards .....	5-1-5
Section III		Normal Procedures .....	5-1-7
Paragraph	5-1-11	Preflight Operation Check .....	5-1-7
	5-1-12	Static Electricity Discharge .....	5-1-8
	5-1-13	Cargo Hook Operation .....	5-1-8
Section IV		Emergency Procedures .....	5-1-9
Paragraph	5-1-14	Electrical Failure .....	5-1-9
Section V		Performance .....	5-1-11
Paragraph	5-1-15	General .....	5-1-11
Section VI		Weight and Balance .....	5-1-12
Paragraph	5-1-16	General .....	5-1-12

**CHAPTER 5**

**SUPPLEMENT 1**

**CARGO HOOK**

**LIST OF FIGURES**

<u>FIGURE NO.</u>	<u>DESCRIPTION</u>	<u>PAGE</u>
5-1-1	Center of Gravity Limits .....	5-1-13

**LIST OF TABLES**

<u>TABLE NO.</u>	<u>DESCRIPTION</u>	<u>PAGE</u>
5-1-1	Weight and Balance Information ....	5-1-12

## CHAPTER 5

### SUPPLEMENT 1

#### CARGO HOOK

##### SECTION I. GENERAL

###### 5-1-1. Introduction

1. This supplement must be attached to the Basic Flight Manual when the Enstrom Cargo Hook Kit No. 4220024 is installed and utilized for transportation of external cargo. Operation in compliance with Chapter 1, Operating Limitations, of the Basic Flight Manual is mandatory except as modified by this supplement. Other approved sections and supplemental data are recommended procedures.

###### 5-1-2. Operating Limits

1. This aircraft is certified for operation at gross weights up to 3,000 pounds (1,363 kg) for Restricted category cargo hook operation. A log book entry shall be made when changing category of operation.

2. The cargo hook kit, part number 4220024, comprises of a cargo hook suspended below the pylon by four cables. The hook incorporates an electrical release on the cyclic along with an emergency mechanical release mounted on the pilot's collective. After the initial installation of the cargo hook kit, the cargo hook and suspension cables can be removed or installed without tools.

#### NOTE

**A swivel link is not supplied with the Cargo Hook Kit; however, it is recommended that a swivel link be installed between the suspension cable and the cargo hook.**

## SECTION II. OPERATING LIMITATIONS

### 5-1-3. Type of Operation

1. This aircraft is approved for multiple certificate operation under FAR 133 for Class B Rotorcraft-Load Combinations.

2. Normal operations may be conducted under FAR Part 91 with the cargo hook installed, providing external cargo is not being transported.

### 5-1-4. Weight

1. The total weight of this helicopter and load combination shall not exceed 3,000 pounds (1,363 kg).

2. The maximum external load is 1,000 pounds (454 kg).

### 5-1-5. Center of Gravity Limitations

1. See Section VI, Weight and Balance, and Figure 5-1-1, Weight and Balance.

### 5-1-6. Airspeed Limitations

1. The maximum airspeed when operating with an external load is 80 knots or the appropriate airspeed shown in Figure 1-3 of the Basic Flight Manual, whichever is lower.

---

**CAUTION**

---

**Airspeed with external loads may be limited by controllability. The maximum safe airspeed for satisfactory handling characteristics is dependant upon many variables such as shape, C.G. of the load, length of the sling, location of the suspension points, and rate of climb or descent. Caution should be exercised as the onset of unsatisfactory handling characteristics may be very abrupt.**

**5-1-7. Altitude Limitations**

1. Same as Basic Flight Manual.

**5-1-8. Rotor Limitations**

1. Same as Basic Flight Manual.

**5-1-9. Engine and Transmission Limitations**

1. Same as Basic Flight Manual.

**5-1-10. Placards**

1. These placards must be placed in view of the pilot:

APPROVED FOR CLASS B ROTORCRAFT-LOAD  
OPERATION. OCCUPANCY LIMITED TO ESSENTIAL  
CREW ONLY WHEN CARRYING EXTERNAL LOAD

WITH EXTERNAL LOAD,  $V_{NE}$  IS THE LOWER OF  
80 KNOTS OR AS SHOWN IN FIG. 1-3.

2. This placard is to be installed on the cargo hook:

EXTERNAL LOAD LIMIT 1000 LBS (454 kg)



### SECTION III. NORMAL PROCEDURES

#### 5-1-11. Preflight Operation Check

1. Visual Preflight Check
  - a. Inspect cargo hook condition and security.
  - b. Inspect four suspension cables and their attaching hardware for security and condition.
  - c. Inspect Manual Release cable and Electrical Release wiring and attachments for security and condition.
2. Electrical Release System
  - a. Turn Master switch ON.
  - b. Turn Cargo Release Arm switch ON.
  - c. (S/N 5136 and subsequent) Check that the CARGO HOOK ARMED annunciator illuminates.
  - d. Place a load on the cargo hook beam.
  - e. Press the Cargo Hook Release switch on the pilot's cyclic grip and note that the hook releases. If the Cargo Hook Release switch is held ON, the hook will not reattach. After the switch is released, the hook will reattach.
  - f. Turn the Cargo Release Arm and Master switches OFF.
3. Manual Release System
  - a. Place a load on the cargo hook beam.
  - b. Pull the Manual Release handle on the Pilot's Collective and note that the cargo hook releases. There should be at least .75 inch between the release handle and the collective when the cargo hook releases.

- c. After the hook has released, lower the manual release handle and note that the hook relatches.

### 5-1-12. Static Electricity Discharge

1. The helicopter must be grounded before coming into contact with any ground personnel or picking up the load. Provide the ground crew with the following instructions:

- a. Discharge the helicopter static electricity before attaching the cargo by touching the airframe with a ground wire. If a metal sling is used, the helicopter can be grounded by striking the hook-up ring against the cargo hook. If contact is lost after initial grounding, the helicopter should be regrounded. Electrical ground contact should be maintained until the hook-up is completed.

### 5-1-13. Cargo Hook Operation

1. The Cargo Release Arm switch can be turned OFF in steady cruise flight to prevent unintentional operation. Turn the Cargo Release Arm switch ON during hook-up, take-off and climb-out, and approach for release.

- a. (S/N 5136 and subsequent) The CARGO HOOK ARMED light will be illuminated when the switch is ON.

2. To release the cargo, press the cargo release button on the cyclic grip.

#### NOTE

**The Cargo Release button on the cyclic grip will not operate if the Cargo Release Arm switch is OFF.**

## **SECTION IV. EMERGENCY PROCEDURES**

### **5-1-14. Electrical Failure**

1. Pull the manual release handle located on the bottom of the pilot's collective to drop the external load as desired in the event of an electrical failure or if the electrical release fails to operate.

#### **NOTE**

**The manual cargo release will operate regardless of the position of the CARGO RELEASE ARM switch.**

**INTENTIONALLY LEFT BLANK**

## **SECTION V. PERFORMANCE**

### **5-1-15. General**

1. Use the data published in the Basic Flight Manual. Note however that the climb and cruise performance may be significantly reduced dependent upon the configuration of the external load.

**SECTION VI. WEIGHT AND BALANCE****5-1-16. General**

1. A new weight and balance should be recalculated per the instructions in Chapter 6 of the Basic Flight Manual using the information listed below. Note that a portion of the cargo hook installation normally remains in the aircraft even with hook removed. This is listed as the "Non-removable Installation."

**Table 5-1-1. Weight and Balance Information**

<u>Equipment</u>	<u>Weight</u> ( <u>lbs</u> )	<u>Arm</u> ( <u>in</u> )	<u>Moment</u> ( <u>in-lbs</u> )
Cargo Hook; Non-removable installation	2.48	136.33	338.1
Cargo Hook; Removable installation	9.08	140.08	1278.4
External Load	(XX)	139.0	(XX) x 139.0

2. The Center of Gravity Limits remain the same as listed in the Basic Flight Manual with the exception of the extension in the aft c.g. limit at weights between 2,500 lbs and 3,000 lbs. The maximum aft c.g. limit at and below 2,850 lbs for cargo hook operations is 143.0 inches. At weights between 2,851 and 3,000 lbs, the aft c. g. limit decreases linearly from 143.0 inches to 142.0 inches. See Figure 5-1-1.

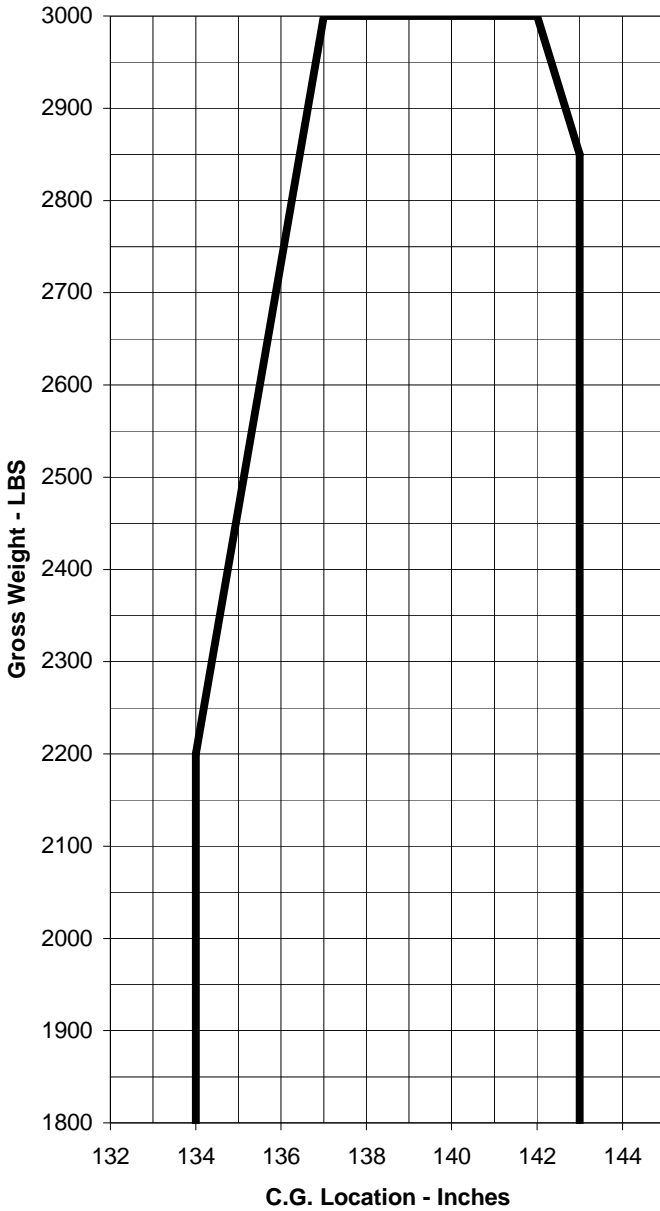

Figure 5-1-1. Center of Gravity Envelope

**INTENTIONALLY LEFT BLANK**



**CHAPTER 5**  
**SUPPLEMENT 2**  
**SNOW SHOES**

**TABLE OF CONTENTS**

<u>SECTION</u>		<u>DESCRIPTION</u>	<u>PAGE</u>
		Table of Contents .....	5-2-1
Section I		General .....	5-2-3
Paragraph	5-2-1	Introduction .....	5-2-3
	5-2-2	Description .....	5-2-3
Section II		Operating Limitations.....	5-2-4
Paragraph	5-2-3	General .....	5-2-4
Section III		Normal Procedures .....	5-2-5
Paragraph	5-2-4	Preflight Check.....	5-2-5
Section IV		Emergency Procedures .....	5-2-7
Paragraph	5-2-5	General .....	5-2-7
Section V		Performance .....	5-2-9
Paragraph	5-2-6	General .....	5-2-9
Section VI		Weight and Balance .....	5-2-10
Paragraph	5-2-7	General .....	5-2-10

**LIST OF TABLES**

<u>TABLE NO.</u>	<u>DESCRIPTION</u>	<u>PAGE</u>
5-2-1	Weight and Balance Information ....	5-2-10

**INTENTIONALLY LEFT BLANK**

## **CHAPTER 5**

### **SUPPLEMENT 2**

#### **SNOWSHOE**

##### **SECTION I. GENERAL**

###### **5-2-1. Introduction**

1. This supplement must be attached to the Basic Flight Manual when the Enstrom Snowshoe Kit No. 4220016 is installed on the helicopter. Operation in compliance with Section 1, Operating Limitations, is mandatory except as modified by this supplement. Other approved sections and supplemental data are recommended procedures.

###### **5-2-2. Description**

1. The snowshoe kit consists of four snowshoe pads, two on each skid tube. These pads increase the footprint of the landing gear, allowing landings in various snow conditions. The forward pads are 2 sq-ft (.19 sq-m) each, and the aft pads are 3.2 sq-ft (.3 sq-m) each.

**SECTION II. OPERATING LIMITATIONS****5-2-3. General**

1. The aircraft may be operated with all four snowshoes installed, only the aft snowshoes installed, or without snowshoes. Other combinations are not authorized.

### **SECTION III. NORMAL PROCEDURES**

#### **5-2-4. Preflight Check**

1. Add the following to the "Exterior Check":
  - a. Paragraph 2-10:
    9. Snowshoes – Check security and condition of Forward and Aft pads. Look for missing hardware and damage to pads or skid.
  - b. Paragraph 2-13:
    6. Snowshoes – Check security and condition of Forward and Aft pads. Look for missing hardware and damage to pads or skid.

**INTENTIONALLY LEFT BLANK**

## **SECTION IV. EMERGENCY PROCEDURES**

### **5-2-5. General**

1. Same as Basic Flight Manual.

**INTENTIONALLY LEFT BLANK**



## **SECTION V. PERFORMANCE**

### **5-2-6. General**

1. Same as Basic Flight Manual.

**SECTION VI. WEIGHT AND BALANCE****5-2-7. General**

1. A new weight and balance should be recalculated per the instructions in Chapter 6 of the Basic Flight Manual using the information listed below.

**Table 5-2-1. Weight and Balance Information**

<u>Equipment</u>	<u>Weight</u> (lbs)	<u>Arm</u> (in)	<u>Moment</u> (in-lbs)
Aft Snowshoes	21.0	161.6	3393.6
Aft Skid Shoe Wear Plates (Removed)	-2.0	160	-320.0
Forward Snowshoes	9.0	100	900.0
Forward Skid Shoe Wear Plate (Removed)	-1.6	100	-160.0

**CHAPTER 5**

**SUPPLEMENT 3**

**EXTERNAL FUEL FILTER**

**TABLE OF CONTENTS**

<u>SECTION</u>		<u>DESCRIPTION</u>	<u>PAGE</u>
		Table of Contents .....	5-3-1
Section I		General .....	5-3-3
Paragraph	5-3-1	Introduction .....	5-3-3
	5-3-2	Description .....	5-3-3
Section II		Operating Limitations.....	5-3-4
Paragraph	5-3-3	General .....	5-3-4
Section III		Normal Procedures .....	5-3-5
Paragraph	5-3-4	Preflight Check.....	5-3-5
Section IV		Emergency Procedures .....	5-3-7
Paragraph	5-3-5	General .....	5-3-7
Section V		Performance .....	5-3-9
Paragraph	5-3-6	General .....	5-3-9
Section VI		Weight and Balance .....	5-3-10
Paragraph	5-3-7	General .....	5-3-10

**LIST OF TABLES**

<u>TABLE NO.</u>	<u>DESCRIPTION</u>	<u>PAGE</u>
5-3-1	Weight and Balance Information ....	5-3-10

**INTENTIONALLY LEFT BLANK**

## **CHAPTER 5**

### **SUPPLEMENT 3**

#### **EXTERNAL FUEL FILTER**

##### **SECTION I. GENERAL**

###### **5-3-1. Introduction**

1. This supplement must be attached to the Basic Flight Manual when the Enstrom External Fuel Filter Kit No. 4220035 is installed on the helicopter. Operation in compliance with Chapter 1, Operating Limitations, is mandatory except as modified by this supplement. Other approved sections and supplemental data are recommended procedures.

###### **5-3-2. Description**

1. The External Fuel Filter Kit comprises a Purolator/Facet filter assembly, P/N 1743640-01, in the main fuel line between the fuel shutoff valve and the engine. The filter assembly incorporates a sump drain valve and a filter bypass with an impending bypass caution light.

**SECTION II. OPERATING LIMITATIONS****5-3-3. General**

1. Same as Basic Flight Manual.

### **SECTION III. NORMAL PROCEDURES**

#### **5-3-4. Preflight Check**

1. Add the following to Paragraph 2-1, "Aft Fuselage - Exterior Check":

9. Fuel Filter:

a. Check security and condition.

b. Check lines for leaks and tightness.

c. With battery switch ON, depress impending bypass test button located on top of the external fuel filter - the A/F FUEL FILTER light located in the caution/warning panel should come on."

2. Add the following to Paragraph 2-19, "Engine Runup":

16. A/F FUEL FILTER Light - Check caution/warning segment panel. If the A/F FUEL FILTER light is ON, the filter must be serviced before further flight.

**INTENTIONALLY LEFT BLANK**



## **SECTION IV. EMERGENCY PROCEDURES**

### **5-3-5. General**

1. Upon an in-flight indication of the A/F FUEL FILTER light, the pilot should perform a power on approach and land as soon as practicable and check the fuel filter for contamination.

2. Upon an in-flight indication of the primary engine FUEL FILTER light in addition to the A/F FUEL FILTER light, the pilot should land immediately to preclude engine stoppage in flight.

---

### **CAUTION**

---

**The pilot should be prepared for engine stoppage at any time during the landing approach.**

**INTENTIONALLY LEFT BLANK**

## **SECTION V. PERFORMANCE**

### **5-3-6. General**

1. Same as Basic Flight Manual.

## SECTION VI. WEIGHT AND BALANCE

### 5-3-7. General

1. A new weight and balance should be recalculated per the instructions in Chapter 6 of the Basic Flight Manual using the information listed below.

**Table 5-3-1. Weight and Balance Information**

<u>Equipment</u>	<u>Weight</u> (lbs)	<u>Arm</u> (in)	<u>Moment</u> (in-lbs)
External Fuel Filter Kit	6.24*	132.8	828.7

\* This includes the additional .2 gallon/.76 liter of unusable fuel in the filter. Note that the useable fuel capacity of the aircraft does not change.

**CHAPTER 5**

**SUPPLEMENT 4**

**BAGGAGE BOX EXTENSION**

**TABLE OF CONTENTS**

<u>SECTION</u>		<u>DESCRIPTION</u>	<u>PAGE</u>
		Table of Contents .....	5-4-1
Section I		General .....	5-4-3
Paragraph	5-4-1	Introduction .....	5-4-3
	5-4-2	Description .....	5-4-3
Section II		Operating Limitations.....	5-4-4
Paragraph	5-4-3	Weight Limitation.....	5-4-4
	5-4-4	Placards .....	5-4-4
Section III		Normal Procedures .....	5-4-5
Paragraph	5-4-5	Preflight Check.....	5-4-5
Section IV		Emergency Procedures .....	5-4-7
Paragraph	5-4-6	General .....	5-4-7
Section V		Performance .....	5-4-9
Paragraph	5-4-7	General .....	5-4-9
Section VI		Weight and Balance .....	5-4-10
Paragraph	5-4-8	General .....	5-4-10

**LIST OF TABLES**

<u>TABLE NO.</u>	<u>DESCRIPTION</u>	<u>PAGE</u>
5-4-1	Weight and Balance Information ....	5-4-10

**INTENTIONALLY LEFT BLANK**

## CHAPTER 5

### SUPPLEMENT 4

#### BAGGAGE BOX EXTENSION

##### SECTION I. GENERAL

###### 5-4-1. Introduction

1. This supplement must be attached to the Basic Flight Manual when the Enstrom Baggage Box Extension Kit No. 4220029 is installed on the helicopter. Operation in compliance with Chapter 1, Operating Limitations, is mandatory except as modified by this supplement. Other approved sections and supplemental data are recommended procedures.

###### 5-4-2. Description

1. The baggage box extension comprises an additional floor from the end of the standard baggage box to the second tail cone bulkhead and fabric bulkhead at the aft end of the extension. It is separated from the standard baggage box by a removable fabric bulkhead. This bulkhead is also the main access to the baggage box extension. The extension was designed to contain bulky, relatively lightweight items which normally do not need to be removed or stowed each flight, such as survival gear. As such, both the capacity, which is determined primarily by the aircraft center of gravity, and the access are somewhat limited.

## SECTION II. OPERATING LIMITATIONS

### 5-4-3. Weight Limitation

1. Maximum Capacity: 50 Pounds (22.7 kg).
2. The aircraft Gross Weight (GW) and Center of Gravity (CG) **MUST** remain within the GW and CG limits specified in the basic flight manual (Reference paragraph 1-13 and Figures 1-4 and 6-8 of the basic flight manual).

---

### CAUTION

---

**The pilot in command is responsible for ensuring that the center of gravity remains within the limits published for the aircraft. It is possible to exceed the center of gravity limits depending upon aircraft empty weight and the load carried.**

### 5-4-4. Placards

1. The following placard must be installed on the fabric bulkhead separating the standard baggage box from the baggage box extension:

MAX LOADING - 50 LBS



### **SECTION III. NORMAL PROCEDURES**

#### **5-4-5. Preflight Check**

1. Add the following to Paragraph 2-11, "Aft Fuselage - Exterior Check":

8. Baggage compartment:

a. Check cargo is properly secured and weight is known.

b. Check security and condition of fabric bulkhead.

**INTENTIONALLY LEFT BLANK**

## **SECTION IV. EMERGENCY PROCEDURES**

### **5-4-6. General**

1. Same as Basic Flight Manual.

**INTENTIONALLY LEFT BLANK**

## **SECTION V. PERFORMANCE**

### **5-4-7. General**

1. Same as Basic Flight Manual.

**SECTION VI. WEIGHT AND BALANCE****5-4-8. General**

1. A new weight and balance should be recalculated per the instructions in Chapter 6 of the Basic Flight Manual using the information listed below.

**Table 5-4-1. Weight and Balance Information**

<u>Equipment</u>	<u>Weight</u> (lbs)	<u>Arm</u> (in)	<u>Moment</u> (in-lbs)
Baggage Box Extension Kit	3.2	216.5	692.8
Cargo in Extension Area	(XX)	216.5	(XX) x 216.5

**NOTE**

**Operation with a solo pilot may require additional ballast to be secured in either the right front seat or footwell to offset the weight in the extended baggage box.**

**CHAPTER 5**  
**SUPPLEMENT 5**  
**CAMERA DOOR**

**TABLE OF CONTENTS**

<u>SECTION</u>		<u>DESCRIPTION</u>	<u>PAGE</u>
		Table of Contents .....	5-5-1
Section I		General .....	5-5-3
Paragraph	5-5-1	Introduction .....	5-5-3
	5-5-2	Description .....	5-5-3
Section II		Operating Limitations.....	5-5-4
Paragraph	5-5-3	General .....	5-5-4
	5-5-4	Deleted	
	5-5-5	Deleted	
Section III		Normal Procedures .....	5-5-5
Paragraph	5-5-6	Preflight Check.....	5-5-5
Section IV		Emergency Procedures .....	5-5-7
Paragraph	5-5-7	General .....	5-5-7
Section V		Performance .....	5-5-9
Paragraph	5-5-8	General .....	5-5-9
Section VI		Weight and Balance .....	5-5-10
Paragraph	5-5-9	General .....	5-5-10

**LIST OF TABLES**

<u>TABLE NO.</u>	<u>DESCRIPTION</u>	<u>PAGE</u>
5-5-1	Weight and Balance Information ....	5-5-10

**INTENTIONALLY LEFT BLANK**



## **CHAPTER 5**

### **SUPPLEMENT 5**

#### **CAMERA DOOR**

##### **SECTION I. GENERAL**

###### **5-5-1. Introduction**

1. This supplement must be attached to the Basic Flight Manual when the Enstrom Camera Door Kit No. 4220079 is installed on the aircraft. Operation in compliance with Chapter 1, Operating Limitations, of the Basic Flight Manual is mandatory except as modified by this supplement. Other approved sections and supplemental data are recommended procedures.

###### **5-5-2. Description**

1. The camera door, P/N 4220079, provides a large vertical sliding window in the right door of the aircraft. This window is intended to allow an observer enough room to use a camera without interference from the plexiglass window. The window may be opened or closed in flight as desired.

**SECTION II. OPERATING LIMITATIONS****5-5-3. General**

1. The left cabin door must be installed anytime the camera door is installed on the right side of the aircraft.

**5-5-4. Deleted****5-5-5. Deleted**

### **SECTION III. NORMAL PROCEDURES**

#### **5-5-6. Preflight Check**

1. Add the following to paragraph 2-10, "Cabin Left Side – Exterior Check":

2. Cabin door – Check cabin door for operation, condition, and security of attachment. Cabin door is required when camera door is installed.

2. Add the following to paragraph 2-15, "Cabin Right Side – Exterior Check":

2. Cabin door – Check camera door for operation, condition, and security of attachment. Check camera window for condition and security of attachment.

**INTENTIONALLY LEFT BLANK**

## **SECTION IV. EMERGENCY PROCEDURES**

### **5-5-7. General**

1. Same as Basic Flight Manual.

**INTENTIONALLY LEFT BLANK**

## **SECTION V. PERFORMANCE**

### **5-5-8. General**

1. Same as Basic Flight Manual.

## SECTION VI. WEIGHT AND BALANCE

### 5-5-9. General

1. A new weight and balance should be recalculated per the instructions in Section 6 of the Basic Flight Manual using the information below:

**Table 5-5-1. Weight and Balance Information**

<u>Equipment</u>	<u>Weight</u> <u>(lbs)</u>	<u>Arm</u> <u>(in)</u>	<u>Moment</u> <u>(in-lbs)</u>
Additional Weight of Camera Door	1.0	100	100



**CHAPTER 5**

**SUPPLEMENT 6**

**EMERGENCY FLOATS**

**TABLE OF CONTENTS**

<u>SECTION</u>		<u>DESCRIPTION</u>	<u>PAGE</u>
		Table of Contents .....	5-6-1
Section I		General .....	5-6-3
Paragraph	5-6-1	Introduction .....	5-6-3
	5-6-2	Description .....	5-6-3
Section II		Operating Limitations.....	5-6-4
Paragraph	5-6-3	General .....	5-6-4
	5-6-4	Airspeed Limits .....	5-6-4
	5-6-5	Altitude Limits .....	5-6-4
	5-6-6	Placards .....	5-6-4
Section III		Normal Procedures .....	5-6-5
Paragraph	5-6-7	Preflight Check.....	5-6-5
	5-6-8	Ferry for Repacking.....	5-6-5
Section IV		Emergency Procedures .....	5-6-7
Paragraph	5-6-9	General .....	5-6-7
	5-6-10	Engine Failure.....	5-6-7
	5-6-11	Emergency Landing On Water with Power.....	5-6-7
Section V		Performance .....	5-6-9
Paragraph	5-6-12	General .....	5-6-9
	5-6-13	Cruise .....	5-6-9
Section VI		Weight and Balance .....	5-6-10
Paragraph	5-6-14	General .....	5-6-10

**CHAPTER 5**

**SUPPLEMENT 6**

**EMERGENCY FLOATS**

**LIST OF TABLES**

<u>TABLE NO.</u>	<u>DESCRIPTION</u>	<u>PAGE</u>
5-6-1	Nitrogen Cylinder Pressure.....	5-6-6

## SUPPLEMENT 6

### EMERGENCY FLOATS

#### SECTION I. GENERAL

##### 5-6-1. Introduction

1. This supplement must be attached to the Basic Flight Manual when the Emergency Float Kit, Number 4220091 is installed on the aircraft. Operation in compliance with Chapter 1, Operating Limitations, of the Basic Flight Manual is mandatory except as modified by this supplement. Other approved sections and supplemental data are recommended procedures.

##### 5-6-2. Description

1. The emergency floats are designed to allow the aircraft to make a safe landing on water during an emergency situation. They are not designed for day-to-day operations involving take-offs and landings to the water and are not certified for take-offs from the water.

2. The Emergency Float Kit, part number 4220091, consists of six separate floats, three mounted on each landing gear skid, and a nitrogen cylinder mounted under the belly of the cabin. Each of the six floats has two separate compartments and is stowed, deflated, on top of the landing gear skid tube in its own container. The cylinder is discharged by pulling a handle mounted on the pilot's cyclic. This cylinder is plumbed to each of the individual floats and, when discharged, fully inflates them within 15 seconds.

#### NOTE

**Safe water landings with inflated Emergency Floats have been demonstrated on calm sea. They are not certified for ditching. Some countries may prohibit certain over-water operations.**

## SECTION II. OPERATING LIMITATIONS

### 5-6-3. General

1. Operations with the floats stowed must be conducted within the limitations of the basic Rotorcraft Flight Manual. Operations with the floats inflated are limited to emergency landings and a one-time ferry flight to a facility where the floats may be inspected and re-packed. During this ferry flight, which may include a take off from the water, the crew is limited to essential personnel only and the airspeed must be limited to the lower of 85 knots or the  $V_{NE}$  in the appropriate limitations section.

### 5-6-4. Airspeed Limits

1. The airspeed limitations are the same as those listed in the basic Rotorcraft Flight Manual with the floats stowed. The airspeed must be kept below 85 knots during float deployment and with the floats inflated.

### 5-6-5. Altitude Limits

1. Do not deploy the floats more than 4000 feet above the intended landing area.

### 5-6-6. Placards

1. Installed above windshield:

Maximum airspeed 85 knots with floats inflated.

### **SECTION III. NORMAL PROCEDURES**

#### **5-6-7. Preflight Check**

1. Add the following to the Before Exterior Check, (Paragraph 2-8):

- a. Inspect float inflation control handle (on pilot's cyclic) for condition and security.

2. Add the following to the Exterior Check, Left Side (Paragraph 2-10 and 2-11):

- a. Inspect float assemblies for condition and security. Any damage to the covers is an indication of possible damage to the floats.
- b. Inspect all visible hoses and lines for condition and security.

3. Add the following to the Exterior Check, Right (Paragraph 2-14 and 2-16):

- a. Inspect float assemblies for condition and security. Any damage to the covers is an indication of possible damage to the floats.
- b. Inspect all visible hoses and lines for condition and security.

4. Add the following to the Cabin Front Area - Exterior Check (Paragraph 2-17):

- a. Inspect cylinder for condition and security. Check safety pin is removed. Check cylinder pressure is within  $\pm 50$  PSI of the value listed in the Table 5-6-1.

#### **5-6-8. Ferry for Repacking**

1. Make sure that the situation which caused the emergency has been corrected.

2. Make sure that the aircraft is safe to fly. Pay special attention to the tail rotor and tail rotor drive systems for signs of strikes.
3. For the ferry flight, personnel on board the aircraft is limited to essential crew only.
4. Maintain airspeed below 85 knots IAS or the appropriate  $V_{NE}$ , whichever is lower.

**Table 5-8-1. Nitrogen Cylinder Pressure**

Temperature		Cylinder Pressure PSI
Degrees C	Degrees F	
60.2	140	5094
54.6	130	5013
49.0	120	4928
43.4	110	4842
37.8	100	4756
32.2	90	4671
26.7	80	4586
21.1	70	4500
15.6	60	4414
10.0	50	4329
4.4	40	4244
-1.1	30	4158
-6.7	20	4072
-12.2	10	3987
-17.8	0	3906

Note: Check that cylinder pressure is within  $\pm 50$  PSI of the value listed in the table above.

## SECTION IV. EMERGENCY PROCEDURES

### 5-6-9. General

1. Refer to Chapter 3 of the basic Rotorcraft Flight Manual for general emergency procedures, including autorotation entry techniques, limitations, and recommendations. Touchdown speed should be reduced as much as practicable, however any "normal" autorotation speed should result in a safe landing. If possible, landings should be made in an area free of underwater obstacles such as submerged branches which may damage the floats. Landings and autorotational landings may be made on land with the floats inflated, however the float containers (covers) may be damaged in the process.

### 5-6-10. Engine Failure

1. Enter autorotation
2. Check airspeed is below 85 knots.
3. If landing is to be made in water, lift guard and pull float control handle to inflate floats. Be prepared for changes in the aircraft pitch attitude during the initial stages of the float deployment.

---

### CAUTION

---

**Do not inflate the floats more than 4000 feet above the intended landing area.**

### NOTE

**Full inflation of the floats requires approximately 15 seconds - maintain sufficient altitude, if possible, for full inflation of the floats in the event of an engine failure.**

4. Complete normal autorotational landing.

### 5-6-11. Emergency Landing on Water with Power

1. Inspect the landing area for obstacles, both above and below the water.
2. Slow the aircraft to below 85 knots. The slower the airspeed is prior to float deployment, the less pitching will be experienced during inflation.
3. Lift guard and pull the float control handle to inflate floats.

---

#### CAUTION

---

**Do not inflate the floats more than 4000 feet above the intended landing area.**

#### NOTE

**Full inflation of the floats requires approximately 15 seconds - maintain sufficient altitude, if possible for full inflation of the floats in the event of an engine failure.**

4. Make a normal power-on landing.

---

#### CAUTION

---

**With the aircraft in the water and the engine running, the engine exhaust will propel the aircraft forward. Moving the cyclic aft to stop the forward motion will cause the tail rotor to strike the water. The pilot should make allowance for this forward motion during the landing approach.**

5. Make sure rotor has stopped before exiting aircraft.



## SECTION V. PERFORMANCE

### 5-6-12. General

1. Except for cruise flight, the floats, when stowed, do not appreciably affect the performance of the aircraft.

### 5-6-13. Cruise

1. The floats reduce the cruise performance by an amount approximately equivalent to an additional 200 pounds of gross weight. To determine cruise performance, first determine the aircraft weight, cruise altitude, etc. Then refer to the appropriate cruise performance chart in the basic Rotorcraft Flight Manual. Use the performance curve which is 200 pounds higher than the actual aircraft weight. That is, if the aircraft weight is 2550 pounds, use the 2750 pound curve. For aircraft weights above 2800 pounds, extrapolate the data shown in the figures. This 200-pound adjustment applies to cruise performance only. Hover performance, climb/descent performance,  $V_{NE}$ , etc. are not affected by the addition of the floats.

**SECTION VI. WEIGHT AND BALANCE****5-6-14. General**

1. The floats and the cylinder can be easily removed from the aircraft. The lines, hoses, control handle, and brackets are permanent. A new weight and balance should be calculated per the instructions in Section 6 of the Basic Flight Manual using the information below:

<u>ITEM (lb)</u>	<u>Weight</u>	<u>Arm</u>	<u>Moment (in-lb)</u>
Permanent components	12.91	142.51	1839.76
Floats: Set of six with skid tube extensions	68.29	143.34	9788.6
Nitrogen Cylinder, Full	23.28	109.15	2541.1
Nitrogen Cylinder, Empty	16.0	109.15	1746.4
Total Installed Weight	104.48	135.61	14169.46
Weight without Cylinder	81.20	143.21	11628.45

**CHAPTER 5**

**SUPPLEMENT 7**

**AIR CONDITIONING**

**TABLE OF CONTENTS**

<u>SECTION</u>	<u>DESCRIPTION</u>	<u>PAGE</u>
	Table of Contents .....	5-7-1
Section I	General .....	5-7-3
Paragraph	5-7-1 Introduction .....	5-7-3
	5-7-2 Description .....	5-7-3
Section II	Operating Limitations.....	5-7-5
Paragraph	5-7-3 General .....	5-7-5
Section III	Normal Procedures .....	5-7-6
Paragraph	5-7-4 Pre-flight Check .....	5-7-6
	5-7-5 Before Starting Engine .....	5-7-7
	5-7-6 General Operation .....	5-7-7
	5-7-7 In-Flight Operation.....	5-7-7
	5-7-8 Engine Shutdown.....	5-7-8
Section IV	Emergency Procedures .....	5-7-9
Paragraph	5-7-9 Air Conditioner Malfunctions...	5-7-9
	5-7-10 Electrical System Failure.....	5-7-9
	5-7-11 Compressor Lockup .....	5-7-9
Section V	Performance .....	5-7-11
Paragraph	5-7-12 Torque Available.....	5-7-11
	5-7-13 Hover .....	5-7-11
	5-7-14 Cruise .....	5-7-11
Section VI	Weight and Balance .....	5-7-12
Paragraph	5-7-15 General .....	5-7-12
Section VII	System Description .....	5-7-13
Paragraph	5-7-16 General .....	5-7-13

**CHAPTER 5****SUPPLEMENT 7****AIR CONDITIONING****LIST OF FIGURES**

<u>FIGURE NO.</u>	<u>DESCRIPTION</u>	<u>PAGE</u>
5-7-1	Air Conditioning System Schematic..	5-7-14
5-7-2	Switch and Circuit Breaker Location	5-7-15
5-7-3	Primary Component Location .....	5-7-16

**LIST OF TABLES**

<u>TABLE NO.</u>	<u>DESCRIPTION</u>	<u>PAGE</u>
5-7-1	Weight and Balance Information.....	5-7-12

## CHAPTER 5

### SUPPLEMENT 7

#### AIR CONDITIONING

##### SECTION I. GENERAL

###### 5-7-1. Introduction

1. This supplement must be attached to the Basic Flight Manual when the Air Conditioner Option, as defined by Drawing Number 4220176, is installed on the aircraft. Operation in compliance with Chapter 1, Operating Limitations, of the Basic Flight Manual is mandatory except as modified by this supplement. Other approved sections and supplemental data are recommended procedures.

###### 5-7-2. Description

1. The Air Conditioner, Part Number 4220176, is a vapor cycle system which consists of either two or three evaporator units in the cabin, a compressor which is belt driven off of the lower pulley assembly, and a condenser with an attached blower in the tailcone. The standard installation consists of two evaporator units mounted forward of the instrument console. Each evaporator unit has an integral heat exchanger and blower. As an option, a third evaporator unit may be installed on the cabin backwall behind the pilot's (left) seat. This evaporator is ducted to outlet vents at the top center of the cabin. The evaporators can be run either as coolers with the air conditioner running, or as blowers without the air conditioner running. The compressor is driven by a belt from the lower pulley assembly. The compressor has an electric clutch which engages and disengages the belt drive. The condenser is mounted in the tailcone. Air enters the tailcone through scoops on either side of the top of the condenser heat exchanger. The system uses R-134a (HFC-134a) refrigerant.

2. A third air conditioner option provides compatibility for the installation of litter equipment. This installation has a left hand forward evaporator unit and one aft evaporator unit behind the pilot's (left) seat. The mounting structure for the forward evaporator, located forward of the lower instrument console, allows clearance for the litter in the nose of the aircraft.

## **SECTION II. OPERATING LIMITATIONS**

### **5-7-3. General**

1. Same as Basic Flight Manual.

**SECTION III. NORMAL PROCEDURES****5-7-4. Pre-flight Check**

1. Add the following to the Before Exterior Check (Paragraph 2-8):

- a. Check evaporators and ducting for signs of refrigerant or oil leakage, condition, and security.

2. Add the following to the Aft Fuselage Left Side, Exterior Check (Paragraph 2-11):

- a. Check compressor and drive belt for condition, correct tension, and security.
- b. Check condenser lines for signs of refrigerant or oil leakage, condition, and security.

3. Add the following to the Tailcone Left Side, Exterior Check (Paragraph 2-12):

- a. Check condenser cooling air inlets for signs of debris. If signs are evident, loosen aft baggage box bulkhead curtain and inspect condenser cooling fan for additional signs of debris. Clean as required.
- b. Check condenser for signs of refrigerant or oil leakage, condition, and security at air exit located in bottom of the tailcone.

4. Add the following to the Tailcone Right Side, Exterior Check (Paragraph 2-13):

- a. Check condenser cooling air inlets for signs of debris. If signs are evident, loosen aft baggage box bulkhead curtain and inspect condenser cooling fan for additional signs of debris. Clean as required.



### 5-7-5. Before Starting Engine

1. Add the following to the Before Starting Engine (Paragraph 2-18):
  - a. Air Conditioning - Prior to start, cycle air conditioner ON, listen for magnetic clutch engagement, turn OFF prior to start.

### 5-7-6. General Operation

1. If air conditioner is equipped with third evaporator, a separate blower switch is provided for back seat evaporator.
2. Individual air conditioner jets are located on either side on the main instrument console and in the overhead evaporator ducting for the back seat. These jets may be directed and opened or closed by the pilot and/or passengers.

### 5-7-7. In-Flight Operation

1. The air conditioning system may be turned ON or BLOWERS ONLY during ground run and engine warm up once the engine is at operating RPM (i.e., N<sub>2</sub> above 98%). Proper system operation will be indicated by an increase in engine torque of approximately 2 psi when the system is turned ON.
2. The air conditioning system may be operated in the ON or BLOWERS ONLY positions through out all phases of flight.

#### NOTE

**The torque, TOT, and N1 instrument indications will be higher than "normal" when the air conditioning system is ON.**

**5-7-8. Engine Shutdown**

1. Add the following to the Engine Shutdown (Paragraph 2-38):

- a. Air Conditioning - Turn OFF or BLOWERS ONLY prior to reducing throttle to engine idle.

## **SECTION IV. EMERGENCY PROCEDURES**

### **5-7-9. Air Conditioner Malfunctions**

1. Lack of cooling may be an indication of an air conditioner malfunction. If the air coming out of the air conditioner vents is not cool within a reasonable amount of time after turning the air conditioner ON, turn the air conditioner OFF. The blowers may be operated with the air conditioner OFF if there is no indication that the blowers are malfunctioning.

### **5-7-10. Electrical System Failure**

1. Turn the air conditioner and all evaporator blowers OFF with any sign of electrical failure (e.g., Caution Warning Panel - GEN OUT).

### **5-7-11. Compressor Lock-up**

1. The oil for the compressor is carried by the refrigerant. Loss of refrigerant and oil can result in a compressor lock-up. Should this happen in flight, the fan belt will slip and deteriorate with a lot of smoke and noise. Turn the air conditioner and evaporator blowers OFF and land as soon as practicable to access any other damage prior to continuing flight.

**INTENTIONALLY LEFT BLANK**

## SECTION V. PERFORMANCE

### 5-7-12. Torque Available

1. The torque available data in the maximum torque available chart (Figure 4-4) on page 4-17 of the Basic Flight Manual does not change with the installation of the air conditioning system.

### 5-7-13. Hover

1. When the air conditioner is ON, add 65 lbs to the actual gross weight of the aircraft and read the hover performance from the hover performance chart (Figure 4-6) on page 4-21 of the Basic Flight Manual. Refer to the following example.

2. Assume the following conditions with the air conditioner OFF (Refer to Figure 4-6): 2,000 Ft pressure altitude, 30°C OAT, and 2,850 lbs aircraft gross weight. The HIGE power required is 58 PSI. When the air conditioner is turned ON, add 65 pounds to the actual aircraft gross weight (2,850 lbs + 65 lbs = 2,915 lbs) to compensate for the increase in power required because of the air conditioner. The HIGE power required is 60 PSI with the air conditioner ON.

### 5-7-14. Cruise

1. When the air conditioner is ON, cruise airspeed will be reduced by 2 knots for all gross weights on the cruise performance charts (Figures 4-8 through 4-11) on pages 4-29 through 4-35 of the Basic Flight Manual.

**SECTION VI. WEIGHT AND BALANCE****5-7-15. General**

1. A new weight and balance should be recalculated per the instructions in Chapter 6 of the Basic Flight Manual using the information listed below.

**Table 5-7-1. Weight and Balance Information**

<u>Equipment</u>	<u>Weight</u> (lbs)	<u>Arm</u> (in)	<u>Moment</u> (in-lbs)
Compressor with Clutch, Belt, and Installation Components	15.0	164.1	2461.5
Condenser with Cooling Fan	17.0	211.3	3592.1
Forward Evaporator (one)	10.0	34.8	348.0
Forward Evaporators (two)	19.9	34.8	692.5
Support Structure for One Forward Evaporator	2.3	37.4	86.0
Support Structure for Two Forward Evaporators	2.8	37.4	104.7
Aft Evaporator and Ducting (If installed)	12.8	115.0	1472.0
Line, Fittings, and Miscellaneous Equipment	19.7	148.4	2923.5
<b>Total</b> (2 Forward Evaporators)	<b>74.4</b>	<b>131.4</b>	<b>9774.3</b>
<b>Total</b> (3 Evaporators)	<b>87.2</b>	<b>129.0</b>	<b>11246.3</b>
<b>Total</b> (1 Forward Evaporator and 1 Aft Evaporator)	<b>77.3</b>	<b>140.8</b>	<b>10883.1</b>

## SECTION VII. SYSTEM DESCRIPTION

### 5-7-16. General

1. A simplified plumbing schematic of the air conditioning system is provided in Figure 5-7-1. This schematic shows all of the components and the direction of the refrigerant flow through the system. It also depicts the high pressure and low pressure service ports.

2. Operation of the air conditioning system is controlled by switches located in the lower center avionics panel. Figure 5-7-2 shows the switch and circuit breaker locations for the air conditioning system.

#### NOTE

**The location of the switches and circuit breakers may be different than shown in Figure 5-7-2 depending on the customer specified avionics installed in the aircraft.**

3. The system may be run with either the blowers on or the air conditioner on. When the air conditioner is on, the evaporator blowers are also on. The evaporator blowers may run at either high or low speed in either mode.

4. Figure 5-7-3 shows the location and function of the various air conditioning system components installed in the aircraft.

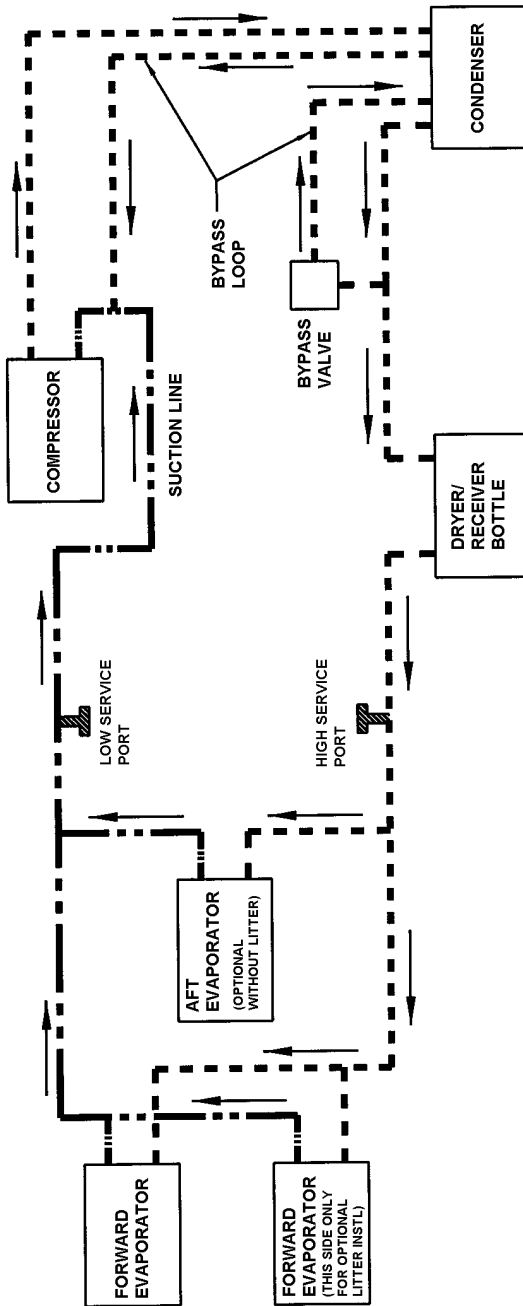

Figure 5-7-1. Air Conditioning System Schematic



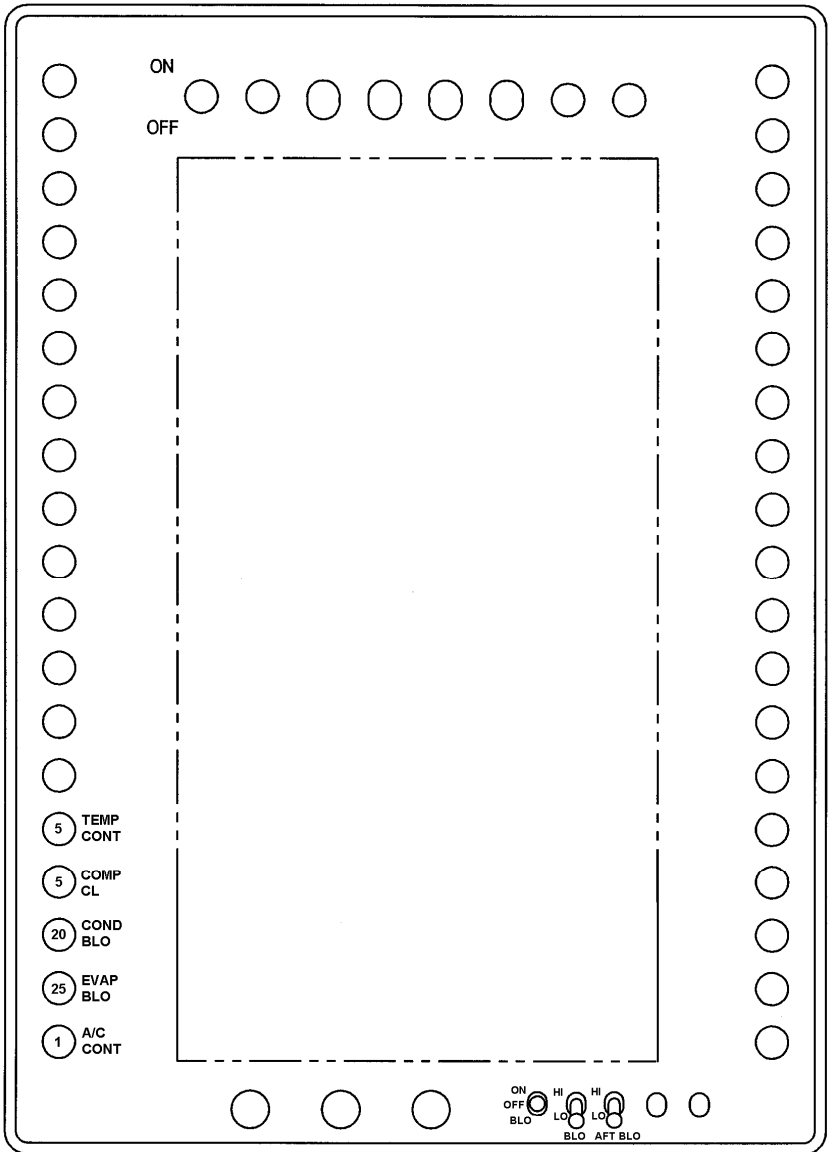
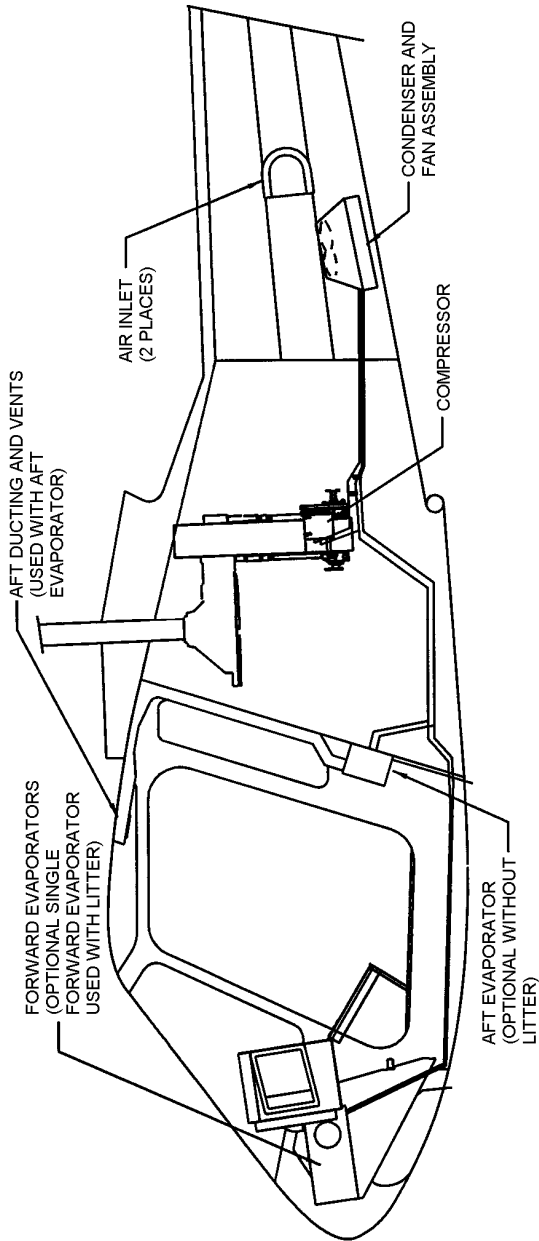
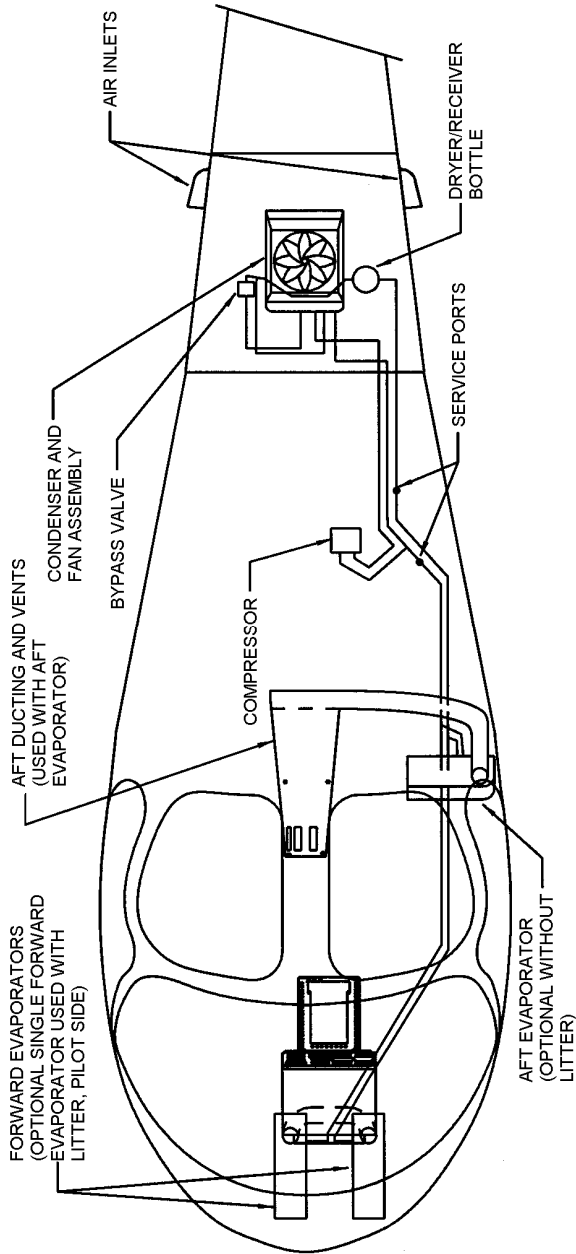

Figure 5-7-2. Switch and Circuit Breaker Location



Sheet 1 of 2

Figure 5-7-3. Primary Component Location



Sheet 2 of 2

Figure 5-7-3. Primary Component Location

**INTENTIONALLY LEFT BLANK**

**CHAPTER 5**

**SUPPLEMENT 8**

**NOSE POSITIONED CAMERA MOUNT**

**TABLE OF CONTENTS**

<u>SECTION</u>		<u>DESCRIPTION</u>	<u>PAGE</u>
		Table of Contents .....	5-8-1
Section I		General .....	5-8-3
Paragraph	5-8-1	Introduction .....	5-8-3
	5-8-2	Description .....	5-8-3
Section II		Operating Limitations.....	5-8-5
Paragraph	5-8-3	General .....	5-8-5
Section III		Normal Procedures .....	5-8-6
Paragraph	5-8-4	Preflight Check.....	5-8-6
Section IV		Emergency Procedures .....	5-8-7
Paragraph	5-8-5	General .....	5-8-7
Section V		Performance .....	5-8-9
Paragraph	5-8-6	General .....	5-8-9
Section VI		Weight and Balance .....	5-8-10
Paragraph	5-8-7	General .....	5-8-10

**LIST OF TABLES**

<u>TABLE NO.</u>	<u>DESCRIPTION</u>	<u>PAGE</u>
5-8-1	Weight and Balance Information.....	5-8-10

**INTENTIONALLY LEFT BLANK**

## CHAPTER 5

### SUPPLEMENT 8

#### NOSE POSITIONED CAMERA MOUNT

##### SECTION I. GENERAL

###### 5-8-1. Introduction

1. This supplement must be attached to the Basic Flight Manual when the Nose Positioned Camera Mount, Number 4220180-5, is installed on the aircraft. Operation in compliance with Chapter 1, Operating Limitations, of the Basic Flight Manual is mandatory except as modified by this supplement. Other approved sections and supplemental data are recommended procedures.

###### 5-8-2. Description

1. The Nose Positioned Camera Mount Kit, P/N 4220180-5, provides provisions for mounting a ball/turret type camera under the nose of the aircraft and for mounting a monitor off of the right side of the instrument panel.

##### NOTE

**Installation of the Nose Positioned Camera Mount Kit does not authorize installation of a camera system. Installation of specific equipment on the mount may require additional authorization from an appropriate certification authority.**

2. The nose mounted camera mount installation consists of an aluminum sheet metal box structure and a steel sheet metal mount. The aft end of the box structure is attached to the vertical panels that support the instrument panel. The lower portion of the box structure is attached to the cabin between the chin windows. The steel mount is located on the outside of the cabin at the forward end of the box structure. It is fastened to the box structure through the fiberglass cabin.

3. The camera mount has been certified, both structurally and in flight test, with equipment weighing 100 lbs/45.5 kg. The frontal area of the equipment was 1.756 ft<sup>2</sup>/.163 m<sup>2</sup> with a center of gravity (CG) located 12.0 inches/30.5 cm below the center line of the external mount.

4. The monitor mount consists of an aluminum angle with gusset supports which is attached to the honeycomb panel on the right side of the instrument panel and was structurally certified with equipment weighing 4.86 lbs/2.21 kg (monitor and articulating arm). The vertical moment arm limit is 7.4 inches/18.8 cm and the horizontal moment arm limit is 10.4 inches/26.4 cm.

5. Once the P/N 4220180-5 kit has been installed, the aircraft can be operated with or without the external steel mount, P/N 4220182-1.



## **SECTION II. OPERATING LIMITATIONS**

### **5-8-3. General**

1. Same as Basic Flight Manual.

**SECTION III. NORMAL PROCEDURES****5-8-4. Preflight Check**

1. Add the following to the “Before Exterior Check”, (Paragraph 2-8):
  - a. Inspect the camera mount box for condition and security of installation.
  - b. Inspect the monitor mount installation for condition and security of installation.
2. Add the following to the “Cabin Front Area – Exterior Check”, (Paragraph 2-17):
  - a. Inspect the camera mount for condition and security of installation.

## **SECTION IV. EMERGENCY PROCEDURES**

### **5-8-5. General**

1. Same as Basic Flight Manual.

**INTENTIONALLY LEFT BLANK**

## SECTION V. PERFORMANCE

### 5-8-6. General

1. Same as Basic Flight Manual.

**SECTION VI. WEIGHT AND BALANCE****5-8-7. General**

1. A new weight and balance should be recalculated per the instructions in Chapter 6 of the Basic Flight Manual using the information listed below.

**Table 5-8-1. Weight and Balance Information**

<u>Equipment</u>	<u>Weight</u> (lbs)	<u>Arm</u> (in)	<u>Moment</u> (in-lbs)
Camera Mount – Internal Box Structure	2.9	52.0	150.8
Camera Mount – External Box Structure	2.3	45.0	103.5
Monitor Mount	.9	70.0	63.0
<b>Total</b>	<b>6.1</b>	<b>52.0</b>	<b>317.3</b>

**CHAPTER 5**

**SUPPLEMENT 9**

**SEARCHLIGHT**

**TABLE OF CONTENTS**

<u>SECTION</u>		<u>DESCRIPTION</u>	<u>PAGE</u>
		Table of Contents .....	5-9-1
Section I		General .....	5-9-3
Paragraph	5-9-1	Introduction .....	5-9-3
	5-9-2	Description .....	5-9-3
Section II		Operating Limitations.....	5-9-4
Paragraph	5-9-3	General .....	5-9-4
	5-9-4	Placards .....	5-9-4
Section III		Normal Procedures .....	5-9-5
Paragraph	5-9-5	Preflight Check.....	5-9-5
	5-9-6	Searchlight Operation .....	5-9-6
	5-9-7	Searchlight/Gimbal Assembly Removal .....	5-9-7
	5-9-8	Searchlight/Gimbal Assembly Installation.....	5-9-8
	5-9-9	Control Box Removal.....	5-9-8
	5-9-10	Control Box Installation .....	5-9-8
Section IV		Emergency Procedures .....	5-9-9
Paragraph	5-9-11	Electrical System Failure.....	5-9-9
	5-9-12	Emergency Pop-Out Float Deployment.....	5-9-9
Section V		Performance .....	5-9-11
Paragraph	5-9-13	General .....	5-9-11
Section VI		Weight and Balance .....	5-9-12
Paragraph	5-9-14	General .....	5-9-12
	5-9-15	Lateral Offset Moment.....	5-9-13

**LIST OF TABLES**

<u>TABLE NO.</u>	<u>DESCRIPTION</u>	<u>PAGE</u>
5-9-1	Weight and Balance Information – (Standard Kit).....	5-9-12
5-9-2	Weight and Balance Information – (Pop-Out Floats) .....	5-9-12
5-9-3	Lateral Offset Moment Information – (Standard Kit).....	5-9-13
5-9-4	Lateral Offset Moment Information – (Pop-Out Floats) .....	5-9-13



## SUPPLEMENT 7

### SEARCHLIGHT

#### SECTION I. GENERAL

##### 5-9-1. Introduction

1. This supplement must be attached to the Basic Flight Manual when the Searchlight Kit, P/N 4220056 is installed on the aircraft. Operation in compliance with Chapter 1, Operating Limitations, of the Basic Flight Manual is mandatory except as modified by this supplement. Other approved sections and supplemental data are recommended procedures.

##### 5-9-2. Description

1. The Searchlight Kit, P/N 4220056, provides for installation of a SpectroLab, Inc. SX-5 Starburst® Searchlight. Two mounting options allow for either a standard mount or an elevated mount. The elevated mount must be used if the aircraft is equipped with the Emergency Floats Kit, P/N 4220091.

2. The Searchlight Kit consists of a tubular mount that attaches to the right side of the landing gear assembly aft crosstube and the associated airframe wiring installation. The SX-5 Starburst® system consists of the searchlight and gimbal assembly, junction box assembly, control box assembly, and associated wiring harnesses. The electrical power circuit for the searchlight is protected by a 40 amp voltage limiter (fuse) located in the keel assembly under the cabin floor.

#### NOTE

**This flight manual supplement provides general operating procedures for the SX-5 Starburst® Searchlight. Always refer to the latest revision of the SX-5 Starburst® Searchlight User's Manual (Doc# 031718) for specific operating procedures.**

**SECTION II. OPERATING LIMITATIONS****5-9-3. General**

1. Same as Basic Flight Manual.

**5-9-4. Placards**

1. The following placard must be installed in view of the aircraft crew (SpectroLab P/N 031751):

- MONITOR ELECTRICAL LOADMETER WITH SEARCHLIGHT ON. REDUCE ELECTRICAL LOAD AS NEEDED TO REMAIN WITHIN CONTINUOUS OPERATING LIMITS.
- MAGNETIC COMPASS UNRELIABLE WHEN SEARCHLIGHT IS OPERATING.
- TURN OFF SEARCHLIGHT WHEN ENTERING CLOUDS OR FOG. DO NOT OPERATE SEARCHLIGHT BELOW 50 FEET.
- RETURN SEARCHLIGHT TO HORIZONTAL BEFORE LANDING

2. The following placard must be installed in view of the aircraft crew if the aircraft is equipped with the emergency pop-out floats:

WARNING  
TURN SEARCHLIGHT OFF  
BEFORE DEPLOYING EMERGENCY  
POP-OUT FLOATS

### SECTION III. NORMAL PROCEDURES

#### 5-9-5. Preflight Check

1. Perform the following preflight check of the searchlight installation:

#### NOTE

**Refer to the latest revision of the SX-5 Starburst® Searchlight User's Manual (Doc# 031718) for specific preflight check procedures.**

- a. Check searchlight wing bolts for tightness and safety lanyards are attached.
- b. Check searchlight to gimbal assembly and gimbal assembly to aircraft safety lanyards attached.
- c. Check searchlight to aircraft mounting system is secure.
- d. Check searchlight for excessive side-to-side or up-down movement.
- e. Check electrical cables for security and signs of abrasion.
- f. Check all visible fasteners for security and corrosion.
- g. Check the searchlight front window for cleanliness and damage.

**WARNING**

**Refer to the latest revision of the SX-5 Starburst® Searchlight User's Manual (Doc# 031718) for safety information regarding operation of the searchlight (Section 2, paragraph 2).**

**NOTE**

**The following checks may require external power.**

h. Verify on-off, eight-way control, and focus control of the searchlight system.

**5-9-6. Searchlight Operation****WARNING**

**Refer to the latest revision of the SX-5 Starburst® Searchlight User's Manual (Doc# 031718) for safety information regarding operation of the searchlight (Section 2, paragraph 2).**

**NOTE**

**Refer to the latest revision of the SX-5 Starburst® Searchlight User's Manual (Doc# 031718) for specific operating procedures.**

1. Turn searchlight on by moving the OFF-ON-START switch on the hand held control box from OFF to START position and hold until lamp starts (approximately 3 to 5 seconds). Release the switch once the lamp starts.

## NOTE

### **Monitor the aircraft electrical load during searchlight operation.**

2. Move and position the searchlight using the 8-way switch on the hand held control box.
3. Focus and change the diameter of the light beam by pressing the FOCUS switch on the hand held control box. Release the switch when the beam is the desired size.
4. Extinguish the searchlight by placing the OFF-ON-START switch in the OFF position.

### **5-9-7. Searchlight/Gimbal Assembly Removal**

1. Disconnect the electrical connectors from the searchlight and the gimbal assembly.
2. Disconnect the safety pin and lanyard from the aircraft mount.

## CAUTION

**The searchlight/gimbal assembly weighs approximately 21.5 lbs/9.8 kg.**

3. Support the searchlight/gimbal assembly and remove the quick release pin from the aircraft.
4. Remove the searchlight/gimbal assembly from the aircraft searchlight mount.
5. Secure the electrical harness to the aircraft mount.

### **5-9-8. Searchlight/Gimbal Assembly Removal**

1. Insert the searchlight/gimbal assembly into the aircraft mount and insert the quick release pin.

#### **NOTE**

**Install the searchlight/gimbal assembly with the horizontally mounted servo motor orientated outboard away from the aircraft.**

2. Attach the gimbal assembly lanyard to the aircraft mount with the safety pin and clip.

3. Connect the electrical connectors to the searchlight and the gimbal assembly.

### **5-9-9. Control Box Removal**

1. Disconnect the control box electrical connector from the copilot's connector box located on the right aft side of the cabin floor and remove the control box.

### **5-9-10. Control Box Installation**

1. Connect the control box electrical connector to the connector on the copilot's connector box located on the right aft side of the cabin floor.

## SECTION IV. EMERGENCY PROCEDURES

### 5-9-11. Electrical System Failure

1. Turn the searchlight OFF with any sign of electrical system failure (e.g., Caution Warning Panel - DC GEN).

### 5-9-12. Emergency Pop-Out Float Deployment

#### WARNING

**The searchlight beam will damage the floats if aimed at the floats. The searchlight must be OFF before deploying the floats.**

1. Turn the searchlight OFF before deploying the emergency pop-out floats.

**INTENTIONALLY LEFT BLANK**



## **SECTION V. PERFORMANCE**

### **5-9-13. General**

1. Same as Basic Flight Manual.

**SECTION VI. WEIGHT AND BALANCE****5-9-14. General**

1. A new weight and balance should be recalculated per the instructions in Chapter 6 of the Basic Flight Manual using the information listed below.

**Table 5-9-1. Weight and Balance Information**  
**(Standard Kit)**

<u>Equipment</u>	<u>Weight</u> (lbs)	<u>Arm</u> (in)	<u>Moment</u> (in-lbs)
Searchlight Mount with Electrical Harness	5.4	170.1	918.5
Junction Box**	6.3	222.0	1398.6
Searchlight/Gimbal Assembly	21.5	171.3	3683.0
<b>Total*</b>	<b>33.2</b>	<b>180.7</b>	<b>6000.1</b>

**Table 5-9-2. Weight and Balance Information**  
**(Elevated Kit)**

<u>Equipment</u>	<u>Weight</u> (lbs)	<u>Arm</u> (in)	<u>Moment</u> (in-lbs)
Searchlight Mount with Electrical Harness	7.8	168.8	1316.6
Junction Box**	6.3	222.0	1398.6
Searchlight/Gimbal Assembly	21.5	171.3	3683.0
<b>Total*</b>	<b>35.6</b>	<b>179.7</b>	<b>6398.2</b>

\* Total does not include control box and cable (1.5 lbs) or non-removable portion of electrical harness.

\*\* Standard location; location may vary depending on other optional equipment installations.

**5-9-15. Lateral Offset Moment**

1. Use the lateral offset moment information in Tables 5-9-3 or 5-9-4 when computing the lateral center of gravity for the aircraft.

**Table 5-9-3. Lateral Offset Moment Information**  
**(Standard Kit)**

<u>Equipment</u>	<u>Lateral Offset Moment</u> (in-lbs)
Searchlight Mount with Electrical Harness	187.9
Junction Box**	55.4
Searchlight/Gimbal Assembly	1057.8
<hr/>	
Total*	1301.1

**Table 5-9-4. Lateral Offset Moment Information**  
**(Elevated Kit)**

<u>Equipment</u>	<u>Lateral Offset Moment</u> (in-lbs)
Searchlight Mount with Electrical Harness	262.9
Junction Box**	55.4
Searchlight/Gimbal Assembly	1057.8
<hr/>	
Total*	1376.1

\* Total does not include control box and cable (1.5 lbs) or non-removable portion of electrical harness.

\*\* Standard location; location may vary depending on other optional equipment installations.



**INTENTIONALLY LEFT BLANK**

**CHAPTER 5**  
**SUPPLEMENT 10**  
**CHELTON FLIGHT SYSTEMS EFIS**

**TABLE OF CONTENTS**

<u>SECTION</u>	<u>DESCRIPTION</u>	<u>PAGE</u>
	Table of Contents .....	5-10-1
Section I	General .....	5-10-3
Paragraph 5-10-1	Introduction .....	5-10-3
5-10-2	Description .....	5-10-3
5-10-3	List of Abbreviations.....	5-10-4
Section II	Operating Limitations.....	5-10-5
Paragraph 5-10-4	General .....	5-10-5
5-10-5	Placards .....	5-10-5
Section III	Normal Procedures	
Paragraph 5-10-6	Engine Prestart .....	5-10-6
5-10-7	Engine Starting .....	5-10-6
5-10-8	In-Flight Operation.....	5-10-6
5-10-9	Terrain Warning.....	5-10-7
5-10-10	External System Annunciators and Controls .	5-10-10
Section IV	Emergency Procedures	
Paragraph 5-10-11	General .....	5-10-13
5-10-12	Failure Procedures .....	5-10-15
5-10-13	IDU Failure .....	5-10-15
5-10-14	Air Data Attitude Heading Reference System Failure ....	5-10-15
5-10-15	GPS Failure.....	5-10-16
5-10-16	Auxiliary Sensor Failure .....	5-10-17
Section V	Performance	
Paragraph 5-10-17	General .....	5-10-19
Section VI	Weight and Balance	
Paragraph 5-10-18	General .....	5-10-20
Section VII	System Description	
Paragraph 5-10-19	General .....	5-10-21
5-10-20	Remote Sensors.....	5-10-23
5-10-21	Hover Vector .....	5-10-24
5-10-22	Circuit Breakers.....	5-10-26

**CHAPTER 5**  
**SUPPLEMENT 10**  
**CHELTON FLIGHT SYSTEMS EFIS**

**LIST OF FIGURES**

<u>FIGURE NO.</u>	<u>DESCRIPTION</u>	<u>PAGE</u>
5-10-1	Annunciation/Switch Panel.....	5-10-10
5-10-2	EFIS Mute Switch on the Pilot Cyclic.	5-10-12
5-10-3	System Block Diagram .....	5-10-21
5-10-4	Primary Flight Display.....	5-10-22
5-10-5	Multi-Function Display .....	5-10-23
5-10-6	Hover-Vector Display.....	5-10-25
5-10-7	Circuit Breaker Panel.....	5-10-26
5-10-8	Circuit Breaker Panel, Upper Panel ...	5-10-27

**LIST OF TABLES**

<u>TABLE NO.</u>	<u>DESCRIPTION</u>	<u>PAGE</u>
5-10-1	Display Annunciations .....	5-10-13

**CHAPTER 5**  
**SUPPLEMENT 10**  
**CHELTON FLIGHT SYSTEMS EFIS**  
**SECTION I. GENERAL**

**5-10-1. Introduction**

1. This supplement must be attached to the Basic Flight Manual when the Chelton Flight Systems EFIS (Electronic Flight Instrument System), P/N 4220500, is installed on the aircraft. Operation in compliance with Chapter 1, Operating Limitations, of the Basic Flight Manual is mandatory except as modified by this supplement. Other approved sections and supplemental data are recommended procedures.

**5-10-2. Description**

1. The Chelton Flight Systems EFIS is a complete flight/navigation instrumentation system that provides information to a pilot via computer-generated screen displays, or integrated display units (IDU), on panel-mounted hardware. The IDUs depict three-dimensional visual images of the rotorcraft's relation to the terrain surrounding it on the Primary Flight Display (PFD) and on the Multi-Function Display (MFD). The PFD is a perspective view display that provides forward-looking terrain, attitude, altitude, airspeed, vertical speed, direction, and Highway-in-the-Sky navigation. The MFD can display a map with waypoints, fixes, and airfields, terrain, HSI or a combination thereof. The MFD also functions as a standby PFD.

2. The Chelton Flight Systems EFIS provides visual and aural warnings, cautions, and advisories for system monitoring. Warnings consist of a red flag on the IDU and a voice warning that repeats until acknowledged by the pilot by depressing the audio mute switch on either the instrument panel or the cyclic. Cautions consist of a yellow flag on the IDU and a one-time annunciation. Advisories are accompanied by a blue flag or no flag, depending on condition, and either a voice annunciation or a chime.

3. Fuel information is not provided by this installation; weather or traffic information may be provided as options.

### 5-10-3. List of Abbreviations

ADAHRS	Air Data Attitude Heading Reference System
ADC	Air Data Computer
ADF	Automatic Direction Finder
AGL	Above Ground Level
ALT	Altitude
BIOS	Basic Input-Output System
CDI	Course Deviation Indicator
CRC	Cyclic Redundancy Check
DC	Direct Current
DR	Dead Reckoning
EFIS	Electronic Flight Instrument System
FAA	Federal Aviation Administration
FLTA	Forward Looking Terrain Awareness
FMS	Flight Management System
GPS	Global Positioning System
GPWS	Ground Proximity Warning System
GS	Ground Speed
HSI	Horizontal Situation Indicator
IAS	Indicated Air Speed
IDU	Integrated Display Unit
IFR	Instrument Flight Rules
IMC	Instrument Meteorological Conditions
LOC	Localizer
LOI	Loss of Integrity
LON	Loss of Navigation
MFD	Multi-Function Display
MSU	Magnetic Sensor Unit
NACO	National Aeronautical Charting Office
NM	Nautical Mile
NPA	Non-Precision Approach
OAT	Outside Air Temperature
OBS	Omnibearing Selector
PFD	Primary Flight Display
RAIM	Receiver Autonomous Integrity Monitoring
TAS	True Air Speed
TAWS	Terrain Awareness and Warning System
VFR	Visual Flight Rules
VMC	Visual Meteorological Conditions
VOR	VHF Omnidirectional Radio
VSI	Vertical Speed Indicator
WAAS	Wide Area Augmentation System



## SECTION II. OPERATING LIMITATIONS

### 5-10-4. General

1. Rotorcraft operations with the Chelton Flight Systems EFIS are limited to VFR only. IFR procedure training is allowed during VFR/VMC. Planned/deliberate flight during IMC is not authorized.

2. The Chelton Flight Systems FlightLogic EFIS Pilot's Operating Guide and Reference, Document No. 150-045240, Revision K, (or later approved revision) must be immediately available to the pilot.

3. The Chelton Flight Systems EFIS must utilize software version 6.0B-10, or later FAA approved revision.

4. The aircraft is limited to maximum operating temperature of 50°C (122°F) for any operations that require the EFIS.

5. Navigation shall not be predicated upon the use of the helicopter terrain awareness and warning system (TAWS).

### 5-10-5. Placards

1. The following placard shall be located on the instrument panel:

**EFIS DISPLAYS APPROVED FOR  
VFR OPERATIONS ONLY**

### SECTION III. NORMAL PROCEDURES

#### 5-10-6. Engine Prestart

1. EFIS Power Switch – OFF

#### NOTE

**Low voltage during engine start and voltage spikes during generator initialization can affect EFIS durability.**

#### 5-10-7. Engine Starting

1. After engine start and generator operating: EFIS Power Switch – ON
2. The EFIS will perform an automatic Self-Test. A Pass is indicated by a “Push any Key to Continue” screen.
  - a. Failure is indicated by a “BIOS error,” “system not found,” blank screen, screen with no image, continual screen resetting (booting) or a “CRC error.”
3. Verify software version as 6.0B-10, or later FAA approved revision.
4. At this time verify that the databases are current.

---

#### CAUTION

---

**The helicopter should be stationary or in stabilized flight for 90 seconds after applying power for Air Data Attitude Heading Reference System (ADAHRS) initialization.**

#### 5-10-8. In-Flight Operation

1. Normal operating procedures are in the Chelton Flight Systems FlightLogic EFIS Pilot's Operating Guide and Reference, Document No. 150-045240.

2. The Skyway is always based on GPS data. The Skyway does not represent navigation following any sensor other than GPS.

---

### CAUTION

---

**The Skyway will not provide guidance for terrain/obstacle clearance. If the selected approach or flight path is below the terrain, the Skyway will appear to provide flight path guidance through the terrain or obstacle.**

#### 5-10-9. Terrain Warning

1. The Terrain Awareness function of the EFIS is approved as a Terrain Awareness and Warning System (TAWS) that meets the requirements of TSO C151b "Terrain Awareness and Warning." Refer to the Chelton Flight Systems FlightLogic EFIS Pilot's Operating Guide and Reference, Document No. 150-045240, for detailed information about the TAWS.

2. A function provided by the TAWS is the Forward Looking Terrain Awareness (FLTA) warning. The FLTA uses a terrain database and an obstruction database to alert the pilot to hazardous terrain or obstructions in front of the aircraft.

3. TAWS FLTA CAUTION - When a terrain awareness CAUTION occurs, take positive corrective action until the alert ceases. Stop descending or initiate either a climb or a turn, or both, as necessary, based on analysis of all available instruments and information.

4. TAWS FLTA WARNING - If a terrain awareness WARNING occurs, immediately initiate and continue a climb that will provide maximum terrain clearance, or any similar approved vertical terrain escape maneuver, until all alerts cease. Vertical maneuvers are recommended, unless either operating in VMC, or the pilot determines, based on all available information, that turning in addition

to the vertical escape maneuver is the safest action, or both.

5. Both TAWS cautions and warnings are displayed as a popup on the PFD. The MFD scale will automatically set to highlight the threatening terrain.

6. Obstructions are displayed as vertical yellow lines on the PFD and as a  $\wedge$  symbol on the MFD. The symbols are highlighted if the obstruction generates a caution. The symbols are highlighted and flashing if the obstruction generates a warning.

7. To avoid unwanted alerts, the TAWS must be inhibited when:

a. Landing at a landing site that is not included in the airport database.

b. When a VFR approach to an off-airport landing site (using a user waypoint) has not been selected. (For example: Landing in a field without building a VFR approach to the site in the FMS.)

8. When the declutter menu is used to suppress the terrain, the TAWS will not be inhibited unless the TAWS INHIBIT switch is also activated. If the TAWS detects a conflict while the terrain is decluttered, the terrain will be displayed along with the appropriate TAWS caution or warning. After resolving the TAWS conflict, the pilot can again manually declutter terrain.

## WARNING

**The terrain and obstacle display is intended to serve as a terrain awareness tool only. The display and database may not provide the completeness, accuracy and/or fidelity on which to base routine navigation decisions and plan routes or maneuvers to avoid terrain or obstacles. Loss of GPS will result in loss of all terrain cautions, warnings, and visual depiction of terrain on the displays.**

**NOTE**

**Some towers, antennas, and other obstructions may not be included in the obstacle database. Power lines are not included in the database.**

**NOTE**

**The TAWS cautions and warnings are automatically inhibited within 2 NM of a runway included in the database. The TAWS will not provide aural cautions or warnings for obstacles or terrain within 2 NM of a runway included in the database.**

**NOTE**

**TAWS will not provide cautions or warnings for power lines.**

## 5-10-10. External System Annunciators and Controls

1. The EFIS annunciation/switch panel is shown in Figure 5-10-1. The annunciation/switch panel is located on the main instrument panel directly below the MFD.

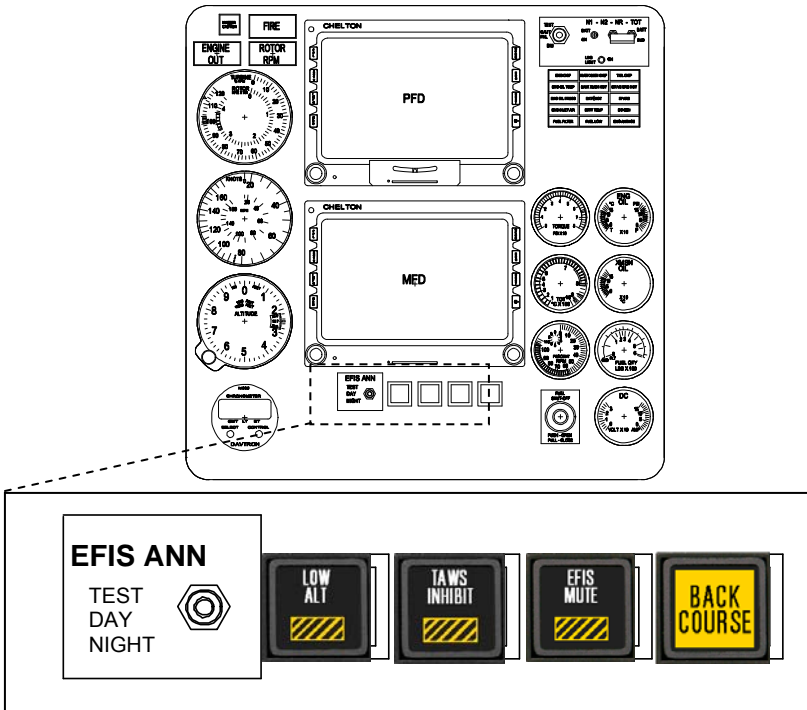

**Figure 5-10-1. Annunciation/Switch Panel**

2. TAWS LOW ALTITUDE ANNUNCIATOR SWITCH - The “LOW ALT” (Amber) annunciator switch, when activated, illuminates and modifies TAWS parameters to reduce nuisance alerts during low altitude operations. Activating the “LOW ALT” TAWS will reduce the required terrain clearance by approximately 30%, both below and ahead of the aircraft. The “LOW ALT” annunciator switch is located directly below the MFD (Figure 5-10-1).

3. TAWS INHIBIT ANNUNCIATOR SWITCH - The “TAWS INHIBIT” (Amber) annunciator switch, when activated, illuminates and inhibits the visual and audible TAWS alerting functions. Activating the “TAWS INHIBIT” will inhibit the TAWS completely. This can be done to prevent cautions and warnings while operating to or from areas that are not recognized as landing areas in the EFIS data base. The pilot should be aware that all TAWS cautions and warnings are inhibited when this feature is activated. The pop-up function is disabled. The “TAWS INHIBIT” annunciator switch is located directly below the MFD (Figure 5-10-1).

4. EFIS MUTE SWITCH - The “EFIS MUTE” (Amber) annunciator switch is located directly below the MFD (Figure 5-10-1). As an option, the EFIS mute switch will be located on the cyclic (Figure 5-10-2) and will be labeled “EFIS MUTE”. The mute switch is a momentary push button switch that mutes the EFIS warning voice alerts only after a warning condition is activated. If a new warning condition occurs after the mute switch is pressed, the new warning will repeat until the mute switch is again pressed or the condition is corrected.

5. BACK COURSE ANNUNCIATOR – The “BACK COURSE” (Amber) annunciator indicates that the NAV receiver is operating in the back course mode as described by the following: Some optional NAV receivers (e.g. Garmin SL-30) provide a “BACK COURSE” mode. When the BACK COURSE mode is selected, the receiver corrects the CDI display for the reverse sensing inherent in a localizer back course signal. With this feature activated, the pilot flies the localizer back course approach using the same techniques as he would on the front course of the localizer. That is, the pilot should fly toward the needle. In addition, this mode also suppresses the glide slope indicator to prevent any false GS indications. The “BACK COURSE” (Amber) annunciator may be located directly below the MFD (Figure 5-10-1).

6. The system annunciations are detailed in Section IV, Emergency Procedures, Table 5-10-1.

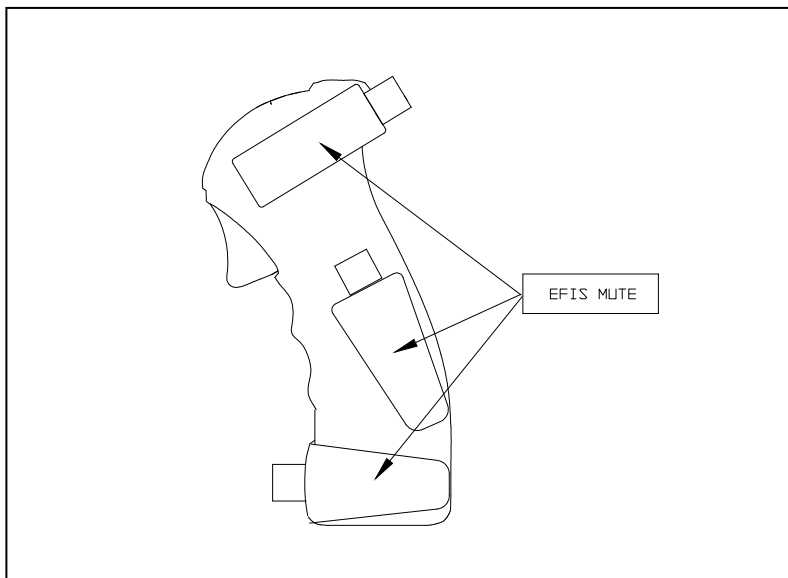

**Figure 5-10-2. EFIS Mute Switch on the Pilot Cyclic**

**(Placard “EFIS MUTE” shown to identify three optional locations of the EFIS Mute Switch.)**



**SECTION IV. EMERGENCY PROCEDURES****5-10-11. General**

1. Table 5-10-1 lists the on-screen cautions, warnings, and advisories issued by the system. The optional equipment installed will determine which annunciations are available for a particular installation.

**TABLE 5-10-1. Display Annunciations**

<b>Annunciation</b>	<b>Cat.</b>	<b>Flag</b>	<b>Aural Annun.</b>	<b>Condition</b>
Obstruction Warning	Warning	OBSTRUCTION	"Obstruction"	Obstruction within TAWS FLTA warning envelope.
Radar Altimeter	Warning	RADALT	Alert Tone	[Option] Radar altimeter is installed, aircraft is below 2000 feet AGL and radar altitude is invalid
TAWS FLTA Warning	Warning	PULL UP	"Terrain, Terrain, Pull Up, Pull Up"	Terrain cell within TAWS FLTA warning envelope.
Traffic Warning	Warning	TRAFFIC	"Traffic"	[Option] Resolution Advisory. Not given if own aircraft below 400' AGL. Not given if target is below 200' AGL (ground target). Audio not generated with TCAS-II system.
AHRS Failure	Caution	NO ATTITUDE	"Attitude Failure"	No valid bank, pitch or heading received from selected AHRS for more than 1 second.
Air Data Failure	Caution	NO AIR DATA	"Air Data Failure"	No valid indicated airspeed, pressure altitude or VSI received from selected ADC for more than 1 second.
Auxiliary Sensor	Caution	AUX SENSOR	"Auxiliary Sensor Failure"	No valid message received from installed optional sensors. Sensor status displayed in FAULTS menu. This message applies to the following optional sensors: 1) RS-232 TAS System, 2) ADS-B System, 3) WSI Datalink System, 4) WX-500 Lightning System, and 5) Analog Interface Unit.
GPS/WAAS Dead Reckoning Mode	Caution	DR ##.##	None	GPS/WAAS in dead reckoning mode with valid ADC and AHRS data. Timer shows time since loss of navigation to indicate quality of DR solution.
GPS/WAAS Loss of Integrity	Caution	GPS LOI	Alert Tone	GPS/WAAS loss of integrity caution.
GPS/WAAS Loss of Navigation	Caution	GPS LON	Alert Tone	GPS/WAAS loss of navigation caution.
GPW/WAAS Failure	Caution	NO GPS	"GPS Failure"	No valid position information received from selected GPS/WAAS for more than 5 seconds.
IDU Overtemp	Caution	EFIS COOL	"EFIS Cooling"	IDU core temperature greater than 95°C.
Minimum Altitude	Caution	MINIMUMS	"Minimums"	Deviation from above to below minimum altitude bug. Causes minimum altitude readout to turn yellow and flash.
OAT Sensor Failed	Caution	OAT SENSOR	Alert Tone	Indicates that OAT sensor has failed.
Obstruction Caution	Caution	OBSTRUCTION	"Obstruction"	Obstruction within TAWS FLTA caution envelope.
SCC Card Failed	Caution	SCC FAIL	Alert Tone	Indicates that SCC card could not be read upon power-up. This means that limits internal to the IDU are being used by the System.
TAWS FLTA Caution	Caution	TERRAIN	"Caution, Terrain"	Terrain cell within TAWS FLTA caution envelope.

<b>Annunciation</b>	<b>Cat.</b>	<b>Flag</b>	<b>Aural Annun.</b>	<b>Condition</b>
TAWS FLTA Function Inoperative	Caution	NO TAWS	Alert Tone	Indicates that aircraft is currently beyond extent of terrain database or a failure condition exists that prevents the TAWS FLTA function from operating.
Traffic Caution	Caution	TRAFFIC	"Traffic"	[Option] Traffic Advisory. Not given if own aircraft below 400' AGL. Not given if target is below 200' AGL (ground target). Audio not generated with TCAS-II system.
VNAV Altitude Deviation	Caution	ALTITUDE	"Altitude"	If not on a descending VNAV profile, deviation greater than 150' from altitude of the current or prior VNAV waypoint after capture. Altitude capture defined as being within 100' of altitude.
Air Data Initializing	Advisory	ADC INIT	Chime	ADC not at full accuracy during warm-up
Automatic Waypoint Sequencing Suspended	Advisory	SUSPEND	Chime	GPS/WAAS automatic waypoint sequencing is suspended. Caused by being on final approach segment prior to arming missed approach, selecting manual GPS/WAAS OBS, or being in holding prior to activating the "CONTINUE" tile.
Countdown Timer Chime	Advisory	---	Chime	Sounds chime when countdown timer reaches 00:00:00.
GPS/WAAS IFR Approach Mode	Advisory	IFR APPR	Chime	GPS/WAAS in NPA mode.
GPS/WAAS Terminal Mode	Advisory	TERMINAL	Chime	GPS/WAAS in Terminal mode.
GPS/WAAS Vectors to Final IFR Approach Mode	Advisory	VTF IFR APPR	Chime	GPS/WAAS in Vectors to Final NPA mode.
GPS/WAAS VFR Approach Mode	Advisory	VFR APPR	Chime	GPS/WAAS in VFR approach mode (active waypoint is part of VFR approach runway and within 6NM of runway).
Level-off	Advisory	---	Altitude Alert Tone	Tone given when within the greater of 1000' or 50% of VSI from uncaptured selected or VNAV waypoint altitude. Inhibited in approach procedures.
Menu Locked	Advisory	MENU LOCK	None	Menu system being used on another IDU.
Parallel Offset	Advisory	PTK = ##	Chime	GPS/WAAS Parallel Offset path advisory. ## is nautical miles left ("L") or right ("R") of main path.
TAWS Inhibit	Advisory	TAWS INHBT	Chime	TAWS inhibited through use of discrete input.
TAWS Low Altitude Mode	Advisory	TAWS LOW ALT	Chime	TAWS low altitude mode activated through use of discrete input.

### **5-10-12. Failure Procedures**

1. In the event of a failure of both IDUs, use the standby instruments and other optional information to complete the current flight. Repair/replace the faulty units before further flight.

2. Failure of the GPS, ADAHRS, singly or in combination, adversely impacts the capabilities of the PFD and MFD. Failure of these components is annunciated visually and audibly. For "Multiple Sensor Failure" conditions refer to Pilot's Operating and Reference Manual Document No. 150-045240. In the event of failure, the following sections detail pilot procedures.

### **5-10-13. IDU Failure**

1. PFD – If the PFD fails, the MFD will automatically revert to the PFD. If this does not occur automatically, press the lower right hand knob on the Multifunction Display (MFD) to display the primary flight instruments on the MFD.

2. MFD – No procedures.

### **5-10-14. Air Data and Attitude Heading Reference System Failure (ADAHRS)**

1. In the event of the loss of air data information (airspeed and altitude) on the PFD, refer to GPS groundspeed and standby airspeed and altimeter.

2. Both the attitude and heading will be lost on the EFIS. Refer to external visual references and other available information for attitude information and magnetic compass for heading information. The EFIS will continue to display all other symbology, including GPS ground track (green diamond) that may be used in lieu of heading. The white Magnetic Heading triangle will disappear from the heading tape when the ADAHRS heading source fails.

### 5-10-15. GPS Failure

1. GPS can degrade or fail as a result of loss of satellite information or GPS equipment failure. GPS degradation is annunciated with a “GPS LOI” caution flag and an aural tone to indicate GPS loss of integrity. In this mode, the GPS data loses the WAAS accuracy but remains as accurate as traditional GPS without RAIM.

2. Further GPS degradation causes the EFIS to lose GPS updating of aircraft position, ground speed and ground track, and the ability to calculate wind information. A “GPS LON” caution flag is displayed to indicate GPS loss of navigation along with a “GPS failure, GPS failure” voice annunciation.

3. GPS failure results in the EFIS operating in “dead reckoning” (DR) mode. The EFIS continues to provide navigational position, groundspeed, and ground track information based upon the last known wind and current air data and heading. In addition, a “DR ##:##” caution flag is displayed to show the pilot the length of time during which the EFIS has been dead reckoning.

4. The accuracy of the dead reckoning solution depends upon how closely the actual wind matches the last known wind. It is important for the pilot to realize that, in the event of a wind mismatch, position errors will grow over time and can become large. Because of this, the dead reckoning solution is considered a short-term aid to situational awareness in event of a GPS failure, and should not be used for an extended period of time. The following factors should be considered in assessing the validity of the dead reckoning solution:

a. The length of time during which the EFIS has been dead reckoning. The longer the time, the greater the position error can be. As an example, with a 10-knot wind mismatch, the dead reckoning solution will be in error by 10 NM after one hour.

b. Accuracy of the last known wind computation. During normal system operation, wind is calculated during periods of relatively wings-level flight (bank < 6°). The wind calculation considers TAS, heading, GS and

track. Factors that affect these parameters can cause inaccuracies in the calculated wind. The pilot should be cognizant of the following potential error sources:

1) TAS: True airspeed errors can be caused by airframe induced pitot-static inaccuracies, pitot-static system leaks or blockages, and inaccurate outside air temperature readings.

2) Heading: Heading errors can be caused by poor ADAHRS calibration, carrying iron-bearing materials in proximity to the MSU, and operation of electric motors or other magnetic field inducing equipment. In addition, for the wind calculation to be accurate, heading must match the vector direction of TAS. As a rule of thumb, if the aircraft is being flown out of trim, the wind calculation should be considered suspect.

3) GS: Poor satellite geometry can cause variations in the groundspeed reading. Although this parameter is generally reliable, it should be considered suspect when a GPS "Loss of Integrity" exists.

4) Track: Poor satellite geometry can cause variations in the track reading. Although this parameter is generally reliable, it should be considered suspect when a GPS "Loss of Integrity" exists.

5) Atmospheric wind changes. Actual wind is rarely constant. The pilot should expect large wind changes with changes in altitude or in the presence of significant weather. The pilot should also consider the effect of surrounding terrain upon wind.

### **5-10-16. Auxiliary Sensor Failure**

1. In the event of an auxiliary sensor failure (e.g. optional weather or traffic sensor), refer to the FAULTS menu to determine which sensor has failed. In a failure condition, associated symbology is automatically removed from the display. No action is required from the pilot.

**INTENTIONALLY LEFT BLANK**

## **SECTION V. PERFORMANCE**

### **5-10-17. General**

1. No change.

## **SECTION VI. WEIGHT AND BALANCE**

### **5-10-18. General**

1. Not applicable.



## SECTION VII. SYSTEM DESCRIPTION

### 5-10-19. General

1. The Chelton Flight Systems EFIS configuration consists of two IDUs, an Air Data Attitude Heading Reference System (ADAHRS), and a Wide Area Augmentation System-Global Positioning System (WAAS-GPS). The IDUs are configured as a Primary Flight Display (PFD) (top display) and a Multi-Function Display (MFD) (bottom display). The PFD receives input from the WAAS-GPS, ADAHRS, and optional auxiliary inputs. The MFD receives input from the PFD. The system inter face is shown in Figure 5-10-3.

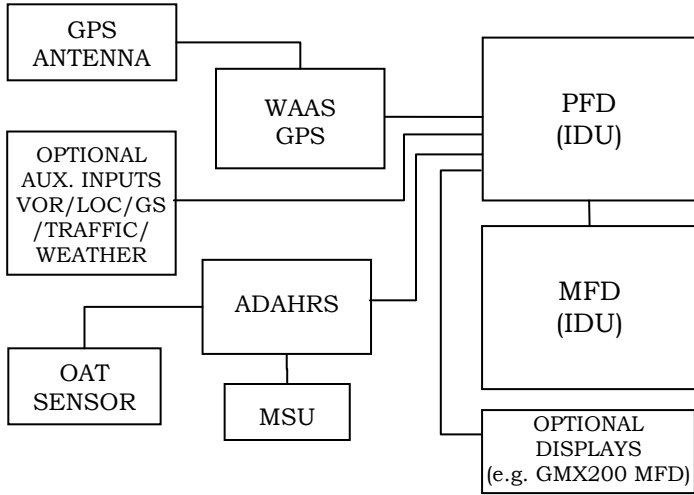

**Figure 5-10-3. System Block Diagram**

2. The PFD is a perspective view display that provides forward-looking terrain, attitude, altitude, airspeed, vertical speed, direction, and Highway-in-the-Sky navigation. The MFD can display a map with waypoints, fixes, and airfields, terrain, HSI or a combination thereof. Figures 5-10-4 and 5-10-5 show the display configurations.



**Figure 5-10-4. Primary Flight Display (PFD)**

3. Each IDU consists of a high-brightness backlit Active Matrix Liquid Crystal Display screen, eight menu buttons, a selection/enter knob, and a display brightness knob. The PFD also has a slip indicator. The buttons, control knobs, and slip indicator are backlit and adjustable by the brightness knob (lower left knob).

4. To obtain additional information and descriptions of the EFIS system functions and performance not provided in this supplement, refer to the Chelton FlightLogic EFIS Pilot's Operating Guide and Reference, Document No. 150-045240.



**Figure 5-10-5. Multi-Function Display (MFD)**

### 5-10-20. Remote Sensors

1. The Chelton Flight Systems ADAHRS unit provides attitude and heading reference and air data to the EFIS. The ADAHRS employs three, solid-state angular rate sensors, and three solid-state accelerometers encased in a single sealed, all-metal housing that is isolated from external shock and vibration. It receives magnetic reference data from a MSU mounted in the tail cone. The ADC portion provides air-speed, altitude, and outside air temperature (OAT) for processing in the EFIS. The ADC receives input from the aircraft's pitot-static system and an OAT probe.

2. The Free Flight Systems WAAS-GPS provides GPS data for aircraft, navigation, obstruction, and terrain data in a self contained unit. The WAAS-GPS consists of an antenna mounted on top of the airframe and a sensor located remotely in the keel (floor frame assembly).

3. The PFD can also receive data from optional equipment such as a radar altimeter, an ADF receiver, marker beacon, and up to two Nav/GS receivers for processing in the EFIS.

### **5-10-21. Hover Vector**

1. Whenever the airspeed is below 30 kts, the flight path marker and waterline are replaced with conventional attitude bars and the hover vector. The hover vector is centered on the attitude bars and is used to indicated direction and groundspeed of drift at low airspeeds. The inner concentric ring indicates 10 kts GS and the outer concentric ring indicates 20 kts. The white dot indicates 0 kts (refer to Figure 5-10-6 and black arrows ❷ and ❸). The gray dot indicates the direction of drift (black arrow ❶), as viewed from above (straight up, the 12:00 position, equates to forward flight while straight down, the 6:00 position, equates to rearward flight). Groundspeed is determined by the location of the gray dot over the concentric rings. Figure 5-10-6 indicates the helicopter moving forward (12:00 direction) at 21 kts.



### 5-10-22. Circuit Breakers

1. Power for the Chelton Flight Systems EFIS consists of 28V DC. The circuit breakers are located in a vertical row on the left hand side of the circuit breaker panel or along the top of the circuit breaker panel, as shown in Figure 5-10-7. The exception is the **EFIS** master circuit breaker (15 amp), which is located in the top row of the circuit breaker panel or in the upper instrument console for aircraft with the partial wide instrument panel, as shown in Figure 5-10-8.

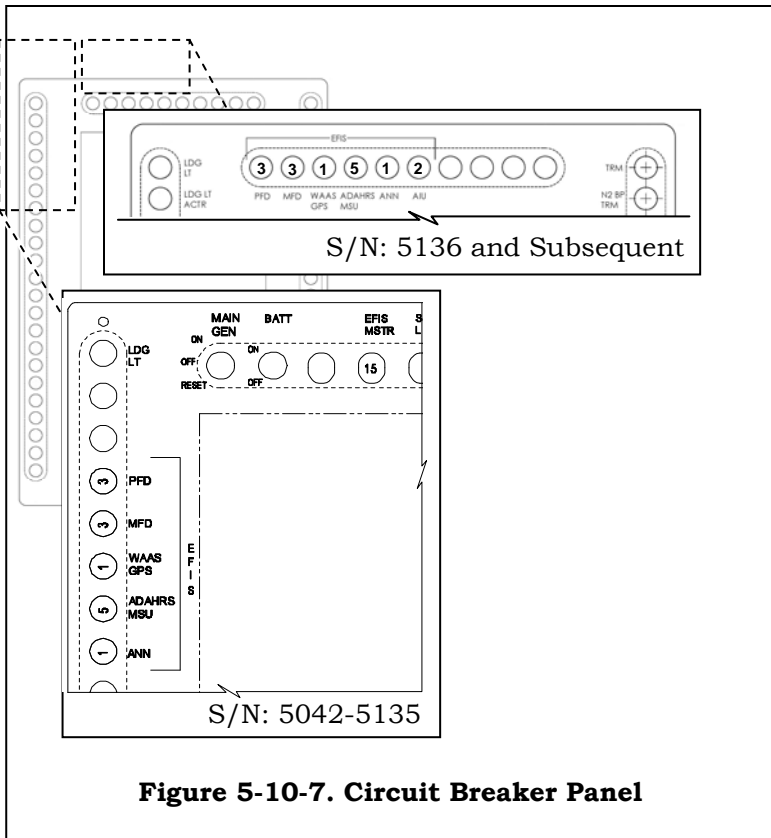

**Figure 5-10-7. Circuit Breaker Panel**

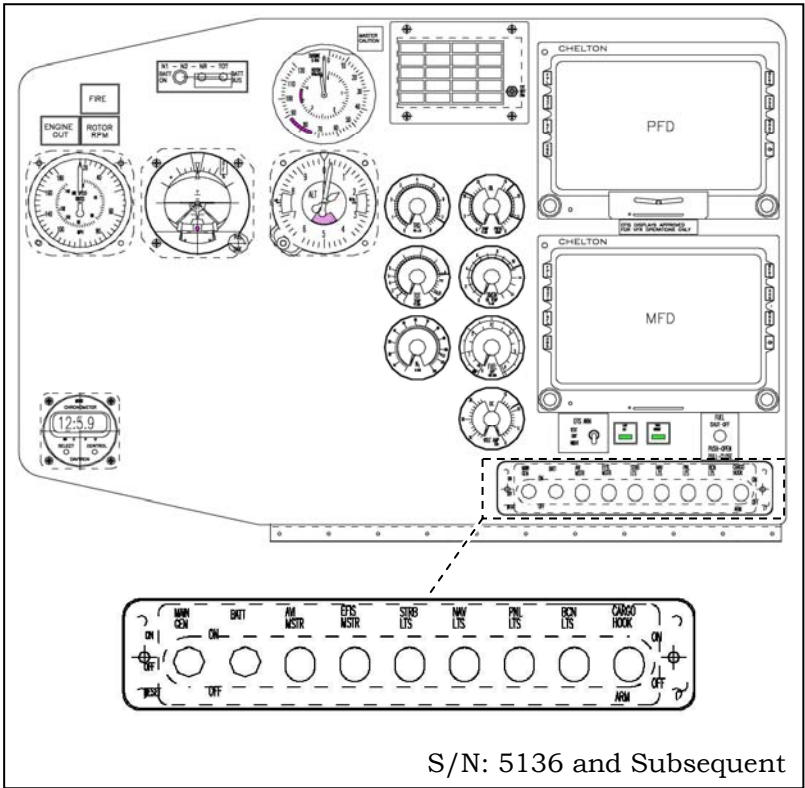

**Figure 5-10-8. Circuit Breaker Panel, Upper Panel**

**INTENTIONALLY LEFT BLANK**



**CHAPTER 6. WEIGHT/BALANCE AND LOADING**

**TABLE OF CONTENTS**

<u>SECTION</u>	<u>DESCRIPTION</u>	<u>PAGE</u>
	Table of Contents .....	6-1
Section I	General .....	6-3
Paragraph	6-1 General .....	6-3
	6-2 Helicopter Station Diagram .....	6-3
	6-3 Loading Charts.....	6-3
	6-4 Center of Gravity Limits .....	6-4
	6-5 Fuel Loading .....	6-4
	6-6 Oil Data .....	6-4
	6-7 Personnel, Cargo, and Baggage ..	6-4
	6-8 Battery .....	6-6
	6-9 Seating Configuration.....	6-7
	6-10 Operation Without Doors .....	6-8
	6-11 Lateral Center of Gravity .....	6-8
	6-12 Sample of Loadings .....	6-8
Section II	Weight and Balance Forms.....	6-9
Paragraph	6-13 Forms F-511-1, F-511-2, F-511-3, F-511-4, and F-511-5 ..	6-9
	6-14 Aircraft Weight and Balance Computation Form .....	6-9

**LIST OF FIGURES**

<u>FIGURE NO.</u>	<u>DESCRIPTION</u>	<u>PAGE</u>
6-1	Form F-511-1 .....	6-12
6-2	Form F-511-2 .....	6-13
6-3	Form F-511-3 .....	6-14
6-4	Form F-511-4 .....	6-15
6-5	Form F-511-5 .....	6-16
6-6	Aircraft Weight and Balance Computation Form .....	6-17
6-7	Helicopter Station Diagram.....	6-18
6-8	Weight and C.G. Limits.....	6-19
6-9	Personnel-Cargo-Baggage-Loading Chart.....	6-20

**CHAPTER 6. WEIGHT/BALANCE AND LOADING****LIST OF FIGURES**

<u>FIGURE NO.</u>	<u>DESCRIPTION</u>	<u>PAGE</u>
6-10	Fuel Loading Chart .....	6-21
6-11	Sample Loadings .....	6-22

**LIST OF TABLES**

<u>TABLE NO.</u>	<u>DESCRIPTION</u>	<u>PAGE</u>
6-1	Seating Configuration.....	6-25
6-2	Center of Gravity Locations .....	6-26

## CHAPTER 6

### WEIGHT/BALANCE AND LOADING

#### SECTION I. GENERAL

##### 6-1. General

1. Chapter 6 contains sufficient instructions and data so that the pilot can compute any combination of weight and balance. This helicopter must be flown within the weight and center of gravity limits stated in Chapter 1, Operating Limitations.

##### 6-2. Helicopter Station Diagram

1. Figure 6-7 shows the helicopter fuselage stations. The station reference datum is 143.4 inches forward of the center of the main rotor head, on the extended centerline of the fuselage. The primary purpose of the figure is to aid personnel in the computation of helicopter weight and balance and loading.

#### NOTE

**The right hand seat track of the forward passenger seat is also stamped to identify C.G. location for occupants in that seat and should be used in calculating C.G. when occupied.**

##### 6-3. Loading Charts

1. Purpose. The loading data contained in this chapter is intended to provide information necessary to properly load the 480B and calculate its weight and center of gravity for the intended flight.

2. Use. From the figures contained in this chapter, weight and moment are obtained for all variable load items and are added to the current basic weight and moment found on Form F-511-5 (Figure 6-5) to obtain the gross weight and moment. Removal or installation of

approved optional equipment will change the helicopter weight and C.G. These changes shall be recorded on Form F-511-5 (Figure 6-5) and a running basic total weight, arm, and moment will be maintained. The pilot will use this running basic total when performing calculations to insure the helicopter is loaded properly.

#### **6-4. Center of Gravity Limits**

1. The gross weight and C.G. are checked using Figure 6-8 to determine if the aircraft is loaded within the proper limits for flight.

#### **NOTE**

**A check should be made to determine whether or not the C.G. will remain within limits for the entire flight as fuel is consumed.**

#### **6-5. Fuel Loading**

1. The purpose of the Fuel Loading Chart (Figure 6-10) is to provide moment/100 data for varying quantity of fuel.

#### **6-6. Oil Data**

1. Oil MIL-PRF-7808. Weight per gallon is 7.74 pounds. Tank capacity is 1.5 gallons for a total weight of 11.6 pounds at station 153.

2. Oil MIL-PRF-23699. Weight per gallon is 8.4 pounds. Tank capacity is 1.5 gallons for a total weight of 12.6 pounds at station 153.

#### **6-7. Personnel, Cargo, and Baggage**

1. The Personnel, Cargo, and Baggage Loading Chart (Figure 6-9) provides moment/100 for varying weights at the designated fuselage stations. Each line has a corresponding fuselage station associated with it. The line labeled "Right Front Passenger" is the line corresponding to

the most forward position of the seat when the seat is in the center set of tracks. The lines labeled "Trackable Seats" represent the forward most and aft most positions the crew seats can be locked into for both the pilot seat and the right front seat when it is located in the right most set of tracks, ie. for the dual pilot configuration. The line associated with FS 101 represents the aft most position the right front seat can achieve when it is locked full aft. The line labeled "Rear Passengers" is for personnel or cargo placed in the rear seats with the seats locked down in position. The line labeled "Baggage Box (AVG)" is an average for the baggage box.

### NOTE

**It is the responsibility of the pilot in command to calculate the weight and balance for the aircraft for each flight including legs within that flight where the loading of personnel or cargo changes.**

---

### CAUTION

---

**It is possible to exceed the aft C.G. limits of the aircraft when operating solo pilot. Relocation of the battery to the forward battery location may be required with solo pilot. It is also possible to exceed the forward C.G. limits of the aircraft when operating with a pilot plus three or more passengers on board. Strategic placement of heavier personnel and baggage may be required to remain within the C.G. envelope of the aircraft.**

2. When the helicopter is operated at critical loading conditions, the exact weight of each individual occupant plus equipment shall be used. To assist the pilot in deciding on loading arrangements to remain within the allowable weight and C.G. range prior to calculating the weight and balance for the aircraft, the following general guidelines are provided:

a. Do not load any cargo, baggage, or weight in the baggage compartment when flying single pilot.

b. When carrying three or more passengers, calculate the C.G. using the specific station for the front passenger seat used in flight. Some restriction in passenger weight for the front seat may apply. Relocation of the battery to the baggage box location may also be necessary to accommodate the higher cabin loads.

c. When carrying two or more passengers, the tradeoff for weight in the right front seat versus weight in the baggage compartment for C.G. control is one pound of baggage for one pound for passengers weighing more than 150 lb., ie. in general if a 200 lb. passenger is riding in the right front seat then approximately 50 lb. will have to be carried in the baggage compartment to offset the additional front seat weight.

#### NOTE

**Whenever possible, restrict the right front passenger seat to 150 lbs. when it is forward of F.S. 98 and load heavier passengers in the rear seats.**

### 6-8. Battery

1. The aircraft battery is normally located in the forward, right side area of the engine compartment (station 135, butt line 25.5). The battery can be moved into the baggage box (station 200, butt line -13.5) to help control the center of gravity, especially with heavy loads in the cabin. Moving the battery will not change the weight of the aircraft but will significantly alter the center of gravity. As such, it is important to know both the present location of the battery and the location of the battery which was used to derive the empty weight (Forms F-511-2 and F-511-5, Figures 6-2 and 6-5).

2. Moving the battery from the forward location to the aft location has the effect of increasing the longitudinal moment and decreasing the lateral moment.

Moving the battery from the aft location to the forward location will have the opposite effect. To determine the change in longitudinal and lateral moments, multiply the weight of the battery by the values in the following table:

Battery Position	Multiplier (in)	
	Longitudinal	Lateral
Moving forward to aft	+65	-39
Moving aft to forward	-65	+39

Example:  
 Moving a 42.5 lb battery from the forward location to the aft location will change the moments as follows:  
     Longitudinal:  $42.5 \times 65 = 2762$  in-lbs  
     Lateral:  $42.5 \times -39 = -1657$  in-lbs

3. The battery type and manufacturer may vary from aircraft to aircraft. For accuracy, weigh the battery prior to relocating when computing the new weight and balance.

## 6-9. Seating Configuration

1. The design of the 480B allows for a number of different seating configurations. When determining the weight and balance for the intended flight, the specific seating configuration must be determined and adjustments to the aircraft basic weight and balance computed. Table 6-1 lists the items normally involved when changing the seating configuration. The aircraft is normally weighed in the pilot/copilot plus one passenger configuration. Review Form F-511-2 to determine if the aircraft was weighed in a different seating configuration and Form F-511-5 to determine if a different seating configuration has been computed for the aircraft basic weight and balance.

### NOTE

**Seating configuration changes are not normally entered onto Form F-511-5.**

## 6-10. Operation Without Doors

1. The standard door weight is 19.5 pounds at station 98.9. The operator is encouraged to weigh the door for accuracy as the actual door weight will vary depending on options and cabin interior. Record the door weight on Form F-511-5 (Figure 6-5) if operating without a door(s), as applicable.

## 6-11. Lateral Center of Gravity

1. For virtually any typical loading, the lateral center of gravity will remain well within the limits for the aircraft (see Chapter 1). However, the pilot should be aware of asymmetrical loadings and check the lateral moment prior to flight, especially if an unusual loading condition is encountered. The appropriate lateral arms (butt lines) are listed in Table 6-2. For items which are not listed, the arm can be determined by measuring from the aircraft centerline to the center of gravity of the item, using negative distances for items left of center and positive distances for items to the right of center. Moment is determined by multiplying the weight of the item by its lateral arm.

## 6-12. Sample Loadings

1. Refer to Figure 6-11 for sample loading calculations.



## SECTION II. WEIGHT AND BALANCE FORMS

### 6-13. Forms F-511-1, F-511-2, F-511-3, F-511-4, and F-511-5

#### NOTE

**Forms F-511-1, F-511-2, F-511-3, F-511-4, and F-511-5 may vary in format depending on the time of printing.**

1. These forms are usually prepared by Enstrom at the time of delivery of the helicopter.

2. Form F-511-1 (Figure 6-1) is the initial weight record of the aircraft. It lists the actual scale readings or indicates that the weight and balance is based on a standard computation for this aircraft. This form is the basis for forms F-511-2 and F-511-5.

3. Form F-511-2 (Figure 6-2) is the basic delivered weight and balance form for the aircraft as delivered.

4. Forms F-511-3 (Figure 6-3) and F-511-4 (Figure 6-4) are the standard and optional equipment list.

5. Form F-511-5 (Figure 6-5) is the basic weight and balance record. It provides a continuous history of the basic weight and moment resulting from structural and equipment changes. The last entry is the current weight and balance status of the basic helicopter.

### 6-14. Aircraft Weight and Balance Computation Form

1. The Aircraft Weight and Balance Computation Form (Figure 6-6) is provided to assure proper preflight weight and balance planning. This form may be reproduced as desired for weight and balance calculations. Use of the form is not mandatory; however, it is recommended for preflight weight and balance planning for the following reasons:

a. It provides a summary of the actual distribution of the load in the helicopter.

b. It records the weight and balance status of the helicopter step by step.

c. It serves as a worksheet on which to record weight and balance calculations, and any corrections that must be made to ensure that the helicopter will be within weight and C.G. limits.

## 2. Form Preparation

a. First Line: This line is always reserved for the basic empty weight, arm, and moment of the aircraft which is usually taken directly from the last line of Form F-511-5. The seating configuration for the intended flight must be determined and adjustments to the aircraft basic weight and balance made as required.

### NOTE

#### **Refer to Table 6-2 for center of gravity locations.**

b. Second line: This line is for the pilot and co-pilot combined weight and moment.

c. Third and fourth lines: These lines are for the passengers, if any.

d. Fifth and Subsequent Lines: These lines are for any baggage or other items of equipment carried aboard the aircraft, and their weight, arm, and moment.

e. Zero Fuel Condition: This line is a sub-total of all of the weights listed in the weight column, and the moments in the moment column. The lateral moment is the total of the moments in the "Lateral Moment" column. The Zero Fuel Weight C.G. is then calculated by dividing the Zero Fuel Condition Moment total by the Zero Fuel Condition Weight total and recording that value in the arm column.

**NOTE**

**DO NOT total the "ARM" Columns.**

f. Fuel: This line is for the takeoff fuel weight, arm, and moment.

g. Takeoff Condition: This line is the final tally of the Zero Fuel Condition subtotals added together with the values on the Fuel line for both the weight and the moment columns. The aircraft takeoff C.G. is then calculated by dividing the moment total by the takeoff weight total and entering that value in the Takeoff Weight arm column.

**NOTE**

**DO NOT total the "ARM" Columns.**

h. The final step in the Weight and Balance form is to plot the Zero Fuel Weight and C.G. and the Takeoff Weight and C.G. on the graph at the far right on the form and connect the two points by a straight line. This will then be a graphical representation of the C.G. shift with fuel burn and from this data the pilot can easily determine where the aircraft will fall relative to the aircraft weight and C.G. limits for the intended flight. The lateral moment can be compared directly to the moment limit ( $\pm 7500$  in-lbs) listed in Chapter 1.

WEIGHT SHEET		
MODEL	SERIAL NUMBER	REG. NO.

WEIGHT POINT	SCALE-LBS.	TARE	NET. WT.	ARM	MOMENT IN. LBS.
LEFT GEAR			(W <sub>L</sub> )	143.4	
RIGHT GEAR			(W <sub>R</sub> )	143.4	
TAIL			(W <sub>T</sub> )	369.7	
TOTAL	XXX	X		X	

LATERAL MOMENT					
LEFT GEAR				-48.0	
RIGHT GEAR				48.0	
TOTAL					

$$LCG = \frac{W_T (369.7) + (W_L + W_R) (143.4)}{W_T + W_L + W_R} = \text{-----}$$

$$= \text{----- IN.}$$

Date \_\_\_\_\_ WEIGHED BY \_\_\_\_\_

F-511-1

Figure 6-1. Form F-511-1

MODEL: 480B		SERIAL NO.:	REG. NO.:	DATE:
AIRCRAFT WEIGHT AND BALANCE COMPUTATION				
		WEIGHT LBS.	ARM IN.	MOMENT IN-LB.
WEIGHT (AS WEIGHTED)				
PLUS: MISSING STD. EQUIPMENT - net			X	
LESS: OPT & SURPLUS WT. (next page)			X	
LESS: ENGINE OIL				
PLUS: UNUSABLE FUEL (1.7 gal per TCDS)				
WEIGHT				
	ACTUAL			
PLUS: ENGINE OIL			X	
PLUS: OPTIONAL EQUIPMENT (next page)			X	
ITEMIZED MISSING STD. EQUIP:		<u>WEIGHT LBS.</u>	<u>ARM IN.</u>	<u>MOMENT IN-LB.</u>
<p><b>Notes:</b> A/C weighed/calculated C.G. using the following data:  <b>Oil:</b> MIL-L-7808 is 7.74 lbs/gal, MIL-L-23699 is 8.4 lbs/gal.  <b>Fuel Wt:</b> Jet A: 6.7 lbs/gal  A/C weighed as a 3 place with dual controls, battery in forward location and operator's manual on shelf behind pilot's seat.</p>				
TOTAL BASIC WEIGHT AND C.G.				

Figure 6-2. Form F-511-2

Model	480B	Serial No.	Reg No.	Date
AIRCRAFT STANDARD AND OPTIONAL EQUIPMENT LIST				
INSTRUMENTS - STANDARD EQUIPMENT		WT.	ARM	MOMENT IN-LB
Airspeed Indicator		.7	70.6	49.2
Altimeter		1.10	69.8	76.8
Clock (See Note)		.5	72.5	36.3
Compass		.75	72.5	54.7
OAT (See Note)		.13	85.0	11.1
Dual Tachometer		1.6	70.0	112.0
Torque Indicator		1.0	70.8	70.8
N1 Indicator		1.8	70.0	126.0
TOT Indicator		1.0	70.9	70.9
Fuel Qty Indicator		1.0	71.4	71.4
Transmission Oil Temp.		1.0	69.8	69.8
Engine Oil Temp./Pressure		1.0	70.2	70.2
AMP/Volt		1.0	70.6	70.6
No.	OPTIONAL EQUIPMENT	WT.	ARM	MOMENT IN-LB
1				
2				
3				
4				
5				
6				
7				
8				
9				
10				
11				
12				
13				
14				
15				
16				
17				
	<b>TOTAL</b>		<b>X</b>	

Note: S/N 5239 and prior: Clock is optional equipment; OAT gauge is located overhead. S/N 5240 and subsequent: Clock is standard equipment and includes OAT function; there is no OAT gauge.

Figure 6-3. Form F-511-3 (Adapted)







**FORM F-170 AIRCRAFT WEIGHT & BALANCE**

Date \_\_\_\_\_ A/C \_\_\_\_\_

Component	Weight	Date		A/C	
		Longitudinal Arm	Longitudinal Moment	Lateral Arm	Lateral Moment
① Basic Empty Weight					
②					
③					
④					
⑤ Zero Fuel Condition					
⑥ Fuel, GAL					
⑦ Takeoff Condition					

⑤ Zero Fuel Condition  
 Fuel, GAL \_\_\_\_\_  
 Takeoff Condition

71.5 Fwd Edge of Cockpit Floor  
 97 to 101 in 1 inch increments Right & Left Pilot  
 89 to 101 in 1 inch increments Right Forward Passenger  
 113 to 117 in 1 inch increments Rear Passengers  
 FS 132 Avg Baggage Box

Gross Weight Pounds

C.G. Location, Inches

STATIONS: 106.0 143.4 166.34 302.65 369.65

Figure 6-6. Aircraft Weight and Balance Computation Form

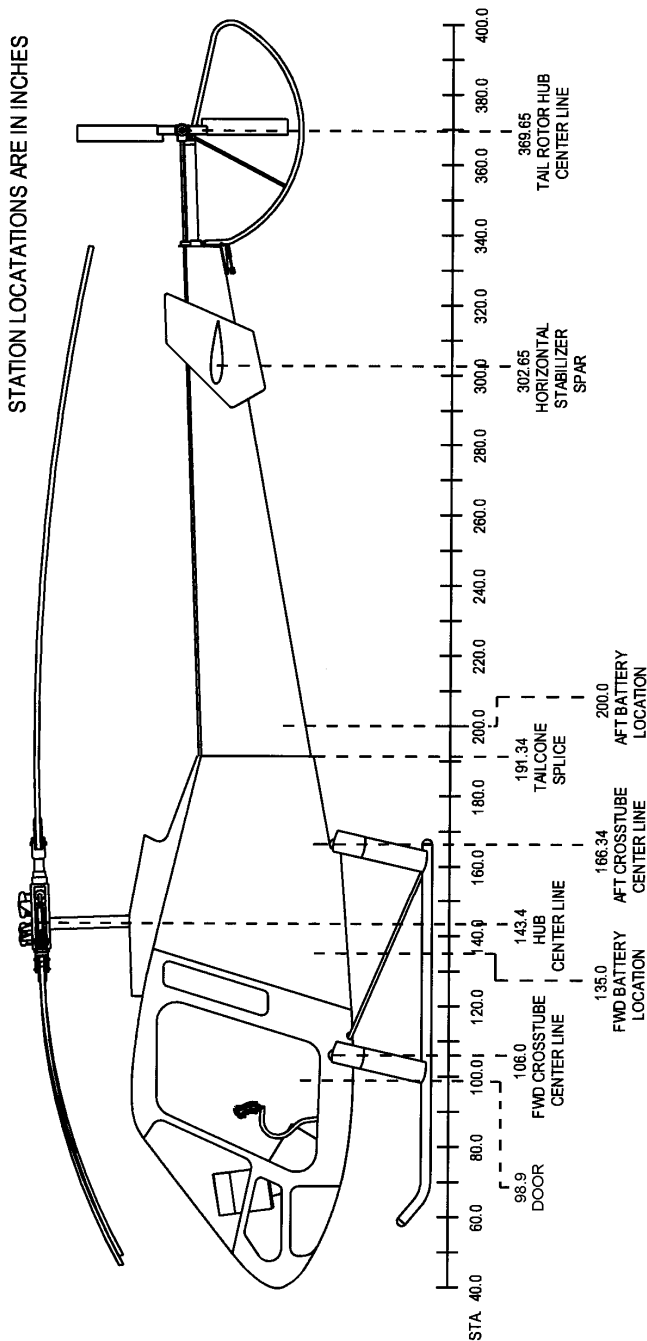

Figure 6-7. Aircraft Station Diagram

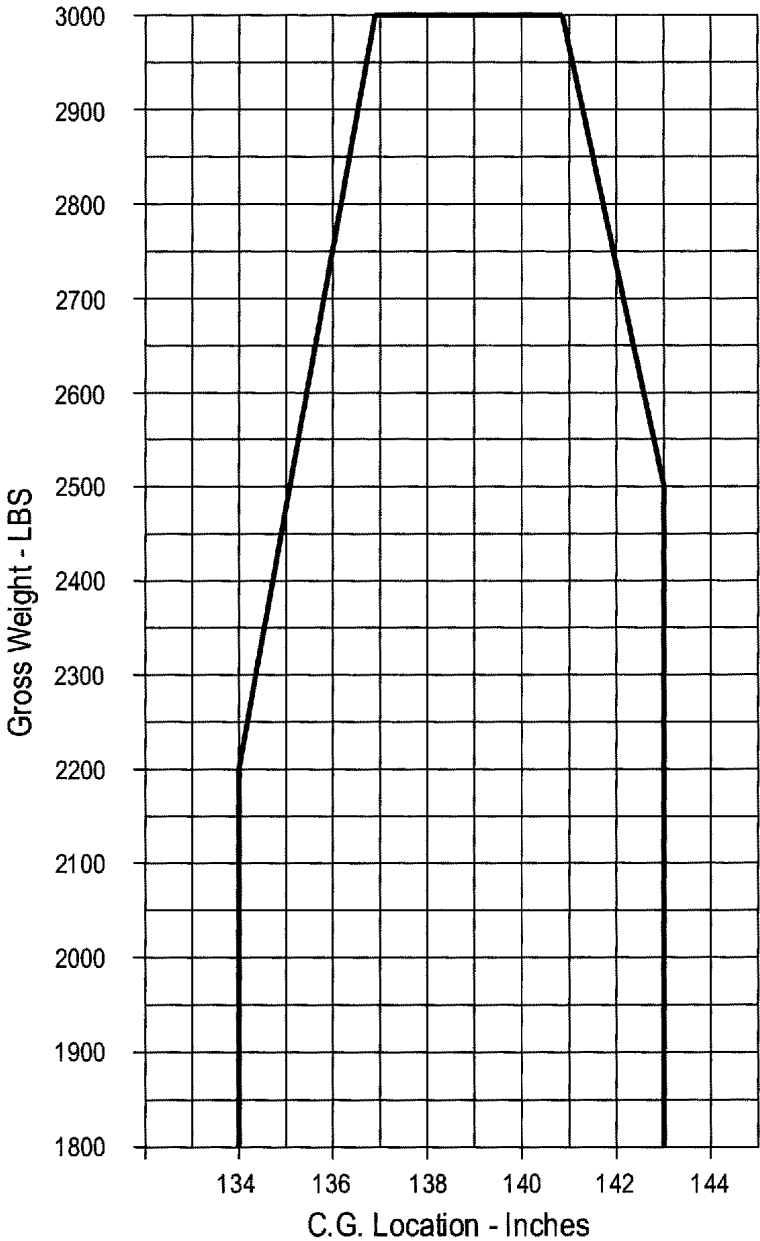

Figure 6-8. Weight and C.G. Limits

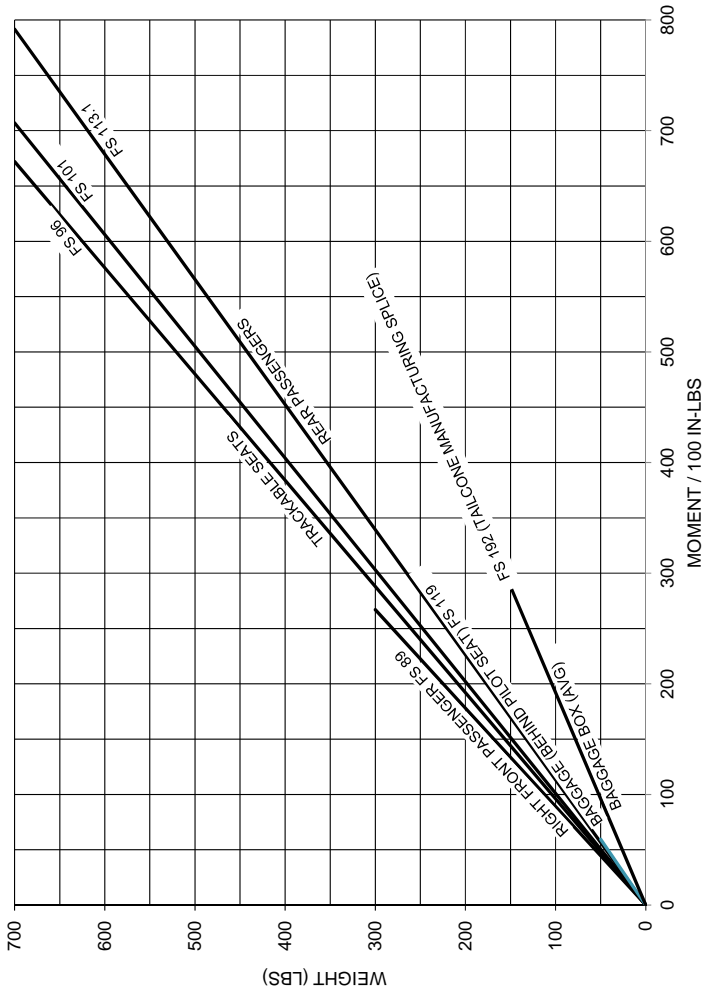

Figure 6-9. Personnel-Cargo-Baggage Loading Chart

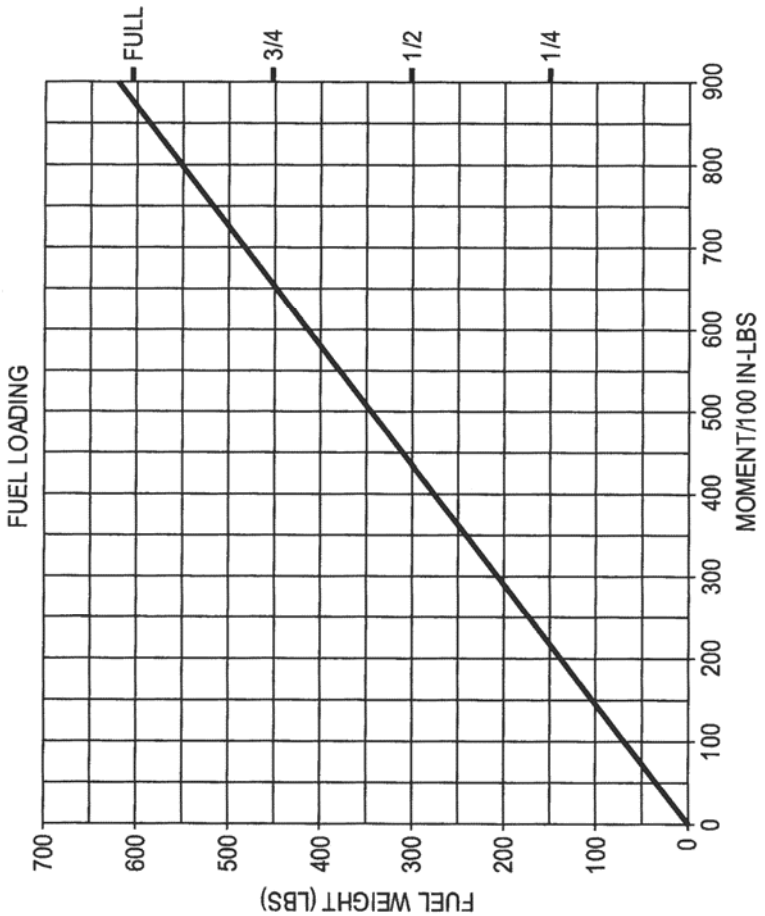

Figure 6-10. Fuel Loading Chart

## SINGLE PILOT

COMPONENT	WEIGHT	ARM	MOMENT	LATERAL ARM	LATERAL MOMENT
BASIC EMPTY WEIGHT & C.G.	1,770	146.8	259,889		
PILOT	180	99.0	17,820	-20.25	-3,645
BAGGAGE (BEHIND PILOT SEAT)	50	119.0	5,950	-24.0	-1,200
BAGGAGE (AFT COMPARTMENT)		192.0			
ZERO FUEL WEIGHT & C.G.	2,000	141.8	283,659		-4,845
FUEL	550	145.0	79,750		
TAKEOFF WEIGHT & C.G.	2,550	142.5	363,409		-4,845

## DUAL PILOT WITH BAGGAGE

COMPONENT	WEIGHT	ARM	MOMENT	LATERAL ARM	LATERAL MOMENT
BASIC EMPTY WEIGHT & C.G.	1,770	146.8	259,889		
PILOT	170	99.0	16,830	-20.3	-3,443
COPILOT	170	99.0	16,830	21.3	3,613
CENTER PAX		113.1			
BAGGAGE (BEHIND PILOT SEAT)	50	119.0	5,950	-24.0	-1,200
BAGGAGE (AFT COMPARTMENT)	60	192.0	11,520		
ZERO FUEL WEIGHT & C.G.	2,220	140.1	311,019		-1,030
FUEL	605	145.0	87,725		
TAKEOFF WEIGHT & C.G.	2,825	141.1	398,744		-1,030

Sheet 1 of 3

Figure 6-11. Sample Loadings

DUAL PILOT WITH PASSENGER AND BAGGAGE

COMPONENT	WEIGHT	ARM	MOMENT	LATERAL ARM	LATERAL MOMENT
BASIC EMPTY WEIGHT & C.G.	1,770	146.8	259,889		
PILOT	170	99.0	16,830	-20.3	-3,443
COPILOT	170	99.0	16,830	21.3	3,613
CENTER PASSENGER	170	113.1	19,227	1.0	170
BAGGAGE (BEHIND PILOT SEAT)	50	119.0	5,950	-24.0	-1,200
BAGGAGE (AFT COMPARTMENT)	90	192.0	17,280		
ZERO FUEL WEIGHT & C.G.	2,420	138.8	336,006		-860
FUEL	580	145.0	84,100		
TAKEOFF WEIGHT & C.G.	3,000	140.0	420,106		-860

Sheet 2 of 3

Figure 6-11. Sample Loadings

## PILOT PLUS 4 PASSENGERS – BATTERY LOCATED AFT

COMPONENT	WEIGHT	ARM	MOMENT	LATERAL ARM	LATERAL MOMENT
BASIC EMPTY WEIGHT & C.G.	1,770	146.8	259,889		
CABIN CONFIGURATION CHANGE	2		-4		-216
PILOT	170	99.0	16,830	-20.3	-3,443
FORWARD PAX	150	89.0	13,350	11.5	1,725
INBOARD REAR PAX	150	113.1	16,965	-2.0	-300
RIGHT REAR PAX	150	113.1	16,965	24.0	3,600
MIDDLE REAR PAX	150	113.1	16,965	14.0	2,100
BATTERY RELOCATED AFT	NO CHANGE		2,697		-1,618
BAGGAGE (AFT COMPARTMENT)	60	192.0	11,520		
ZERO FUEL WEIGHT & C.G.	2,602	136.5	355,177		1,848
FUEL	380	145.0	55,100		
TAKEOFF WEIGHT & C.G.	2,982	137.6	410,277		1,848

Sheet 3 of 3

Figure 6-11. Sample Loadings



**Table 6-1. Seating Configuration\***

<u>Item</u>	<u>Weight</u>	<u>Arm (F.S)</u>	<u>Moment</u>	<u>Lateral Arm (B.L.)</u>	<u>Lateral Moment</u>
Copilot/Passenger Seat	**	†	†	†	†
Removable Flight Controls (All)	6.7	86.8	581.7	16.8	112.5
Flight Control Covers	0.3	76.3	22.9	21.3	6.4
Foot Rest Assembly, Forward Passenger	3.4	63.0	214.2	11.5	39.1
Passenger Seat Cushion, Right Side	5.0	113.1	565.5	14.0	70.0
Passenger Seat Cushion, Left Side	4.5	113.1	509.0	2.0	9.0

- \* Weights are in pounds (lbs) and Arms are in inches (in.)
- \*\* Seat weight will vary depending on the type of Upholstery. Weigh the seat to determine its exact weight.
- † Use the information in Table 6-2 to determine the correct arms and moments for the seat.

**Table 6-2. Center of Gravity Locations\***

<u>Item</u>	<u>Arm (F.S.)</u>	<u>Lateral Arm (B.L.)</u>
Pilot Seat	96, 97, 98, 99, 100, 101	-20.3
Right Front Seat: Outboard Rails	96, 97, 98, 99, 100, 101	21.3
Inboard Rails	89 thru 101 at 1 inch intervals	11.5
Center (Rear) Seat in 3 Seat Configuration	113.1	1.0
Rear Seat with 2 Passengers: Outboard Passenger	113.1	24.0
Inboard Passenger	113.1	1.0
Rear Seat with 3 Passengers: Outboard Passenger	113.1	26.0
Middle Passenger	113.1	14.0
Inboard Passenger	113.1	-2.0
Baggage Behind Pilot Seat (Cabin Shelf)	119.0	-24.0
Baggage Compartment	192.0	
Fuel	145.0	

\* Arms are in inches (in.).

## CHAPTER 7 HELICOPTER AND SYSTEMS DESCRIPTION AND OPERATION

### TABLE OF CONTENTS

<u>SECTION</u>		<u>DESCRIPTION</u>	<u>PAGE</u>
		Table of Contents .....	7-1
Section I		Helicopter .....	7-5
Paragraph	7-1	General Description .....	7-5
	7-2	General Arrangement .....	7-5
	7-3	Principal Dimensions.....	7-5
	7-4	Turning Radius .....	7-5
	7-5	Fuselage .....	7-5
	7-6	Tailcone.....	7-6
	7-7	Landing Gear System .....	7-6
	7-8	Cabin .....	7-7
	7-9	Cabin Doors .....	7-7
	7-10	Seats .....	7-7
	7-11	Instruments and Controls .....	7-8
Section II		Emergency Equipment .....	7-16
Paragraph	7-12	Aircraft Fire Detection System ..	7-16
	7-13	Optional Portable Fire Extinguisher.....	7-17
	7-14	Optional First Aid Kit.....	7-17
Section III		Engine and Related Systems.....	7-18
Paragraph	7-15	Engine.....	7-18
	7-16	Engine Components .....	7-18
	7-17	Engine Compartment Cooling ...	7-19
	7-18	Air Induction System.....	7-19
	7-19	Engine Inlet Air Caution Light ..	7-21
	7-20	Engine Inlet Anti-Icing System..	7-21
	7-21	Engine Fuel Control.....	7-21
	7-22	Fuel Filter Caution Light.....	7-24
	7-23	Turbine Outlet Temperature (TOT) Measurement System .....	7-24
	7-24	Compressor Bleed Air System...	7-24
	7-25	Ignition and Start System .....	7-25
	7-26	Engine Oil Supply.....	7-25
	7-27	Engine Chip Caution Light .....	7-25

**CHAPTER 7 HELICOPTER AND SYSTEMS DESCRIPTION  
AND OPERATION****TABLE OF CONTENTS**

<u>SECTION</u>	<u>DESCRIPTION</u>	<u>PAGE</u>
	7-28 Engine Instruments and Indicators.....	7-26
Section IV	Fuel System .....	7-29
Paragraph	7-29 Fuel System .....	7-29
	7-30 Fuel Quantity System.....	7-31
	7-31 Fuel Management System .....	7-32
Section V	Flight Controls .....	7-33
Paragraph	7-32 Description.....	7-33
	7-33 Collective Pitch Control System	7-33
	7-34 Collective Friction.....	7-37
	7-35 Cyclic Pitch Control System.....	7-39
	7-36 Tail Rotor (Antitorque) Control System .....	7-41
	7-37 Dual Control Removal .....	7-42
Section VI	Power Train.....	7-43
Paragraph	7-38 General Description.....	7-43
	7-39 Main Rotor Transmission .....	7-43
	7-40 Tail Rotor Transmission .....	7-44
	7-41 Tail Rotor Drive Shaft .....	7-44
	7-42 Upper Pulley.....	7-44
	7-43 Lower Drive Pulley.....	7-45
	7-44 Drive Bearing Hot Caution Light .....	7-45
	7-45 Lower Pulley Drive System .....	7-46
	7-46 Overrunning Clutch .....	7-48
	7-47 Main Drive Belt .....	7-48
	7-48 Indicators and Caution Lights ..	7-49
Section VII	Main and Tail Rotor Groups .....	7-51
Paragraph	7-49 Main Rotor System .....	7-51
	7-50 Main Rotor RPM Indicator .....	7-52
	7-51 Rotor RPM Warning System.....	7-52
	7-52 Tail Rotor System .....	7-53

**CHAPTER 7 HELICOPTER AND SYSTEMS DESCRIPTION  
 AND OPERATION**

**TABLE OF CONTENTS**

<u>SECTION</u>		<u>DESCRIPTION</u>	<u>PAGE</u>
Section VIII		Heating and Ventilation.....	7-54
Paragraph	7-53	Bleed Air Heating and Defroster System.....	7-54
	7-54	Windshield Demister .....	7-54
	7-55	Ventilation System .....	7-55
Section IX		Electrical Power Supply & Distribution System .....	7-56
Paragraph	7-56	General .....	7-56
	7-57	Battery .....	7-57
	7-58	External Power Receptacle.....	7-57
	7-59	Generator.....	7-58
	7-60	Generator Caution Light.....	7-59
	7-61	Controls and Indicators.....	7-59
Section X		Lighting.....	7-63
Paragraph	7-62	Position Lights .....	7-63
	7-63	Anticollision Lights.....	7-63
	7-64	Landing Light .....	7-63
	7-65	Instrument Lights .....	7-64
	7-66	Cabin Dome Light .....	7-64
	7-67	Map/Utility Light .....	7-65
Section XI		Flight Instruments .....	7-66
Paragraph	7-68	Airspeed Indicator .....	7-66
	7-69	Optional Pitot Heater.....	7-66
	7-70	Altimeter and Encoder.....	7-66
	7-71	Attitude Indicator .....	7-67
	7-72	Instantaneous Vertical Velocity Indicators.....	7-67
	7-73	Turn and Slip Indicator .....	7-67
	7-74	Outside Air Temperature Indicator .....	7-68
	7-75	Magnetic Compass .....	7-68
	7-75.1	Alternate Static Air Source .....	7-68

**CHAPTER 7 HELICOPTER AND SYSTEMS  
DESCRIPTION AND OPERATION**

**TABLE OF CONTENTS**

<u>SECTION</u>		<u>DESCRIPTION</u>	<u>PAGE</u>
Section XII		Caution & Warning Systems .....	7-69
Paragraph	7-76	Caution & Warning Systems .....	7-69
Section XIII		Miscellaneous Systems .....	7-75
Paragraph	7-77	Ignition Lock Switch.....	7-75
	7-78	Hour Meter .....	7-75
	7-79	Start Counter.....	7-75
	7-80	Power Sockets.....	7-76
	7-81	Headset Jacks.....	7-76

**LIST OF FIGURES**

<u>FIGURE NO.</u>	<u>DESCRIPTION</u>	<u>PAGE</u>
7-1	General Arrangement Diagram .....	7-9
7-2	Principle Dimensions Diagram .....	7-11
7-3	Instrument Panel .....	7-12
7-4	Pedestal Panel .....	7-14
7-5	Slider Control Panel .....	7-20
7-6	Fuel System Diagram .....	7-30
7-7	Collective Control Box .....	7-34
7-8	Collective Friction System .....	7-36
7-9	Cyclic Grip Switches.....	7-39
7-10	Power Train.....	7-47
7-10.1	N1-N2-NR-TOT Switch.....	7-62
7-11	External Power Receptacle.....	7-62.1
7-12	Fuse Panel – 110 Amp System.....	7-62.2
7-12.1	Fuse Panel – 150 Amp System.....	7-62.2
7-13	Warning and Caution Lights.....	7-71

**CHAPTER 7 HELICOPTER AND SYSTEMS DESCRIPTION  
AND OPERATION**

**LIST OF TABLES**

<u>TABLE NO.</u>	<u>DESCRIPTION</u>	<u>PAGE</u>
7-1	Caution Panel Segments .....	7-72
7-2	Warning Lights .....	7-73
7-3	Indicator Caution Activation .....	7-73

**INTENTIONALLY LEFT BLANK**



## CHAPTER 7

### HELICOPTER AND SYSTEMS DESCRIPTION AND OPERATION

#### SECTION I. HELICOPTER

##### 7-1. General Description

1. The Enstrom model 480B helicopter is a 5 place, 3 bladed, single engine helicopter. The aircraft is designed for mission flexibility. It may be configured to transport five (5) people, or easily converted to a three (3) place primary trainer or a solo pilot light cargo transport. Particular attention has been given to make it easily convertible.

##### 7-2. General Arrangement

1. Figure 7-1 depicts the general arrangement of the aircraft.

##### 7-3. Principal Dimensions

1. Figure 7-2 depicts the principal dimensions of the aircraft.

##### 7-4. Turning Radius

1. The turning radius is about 21 feet/6.4 meters when pivoted about the main rotor shaft.

##### 7-5. Fuselage

1. The fuselage consists of the cabin, the center section and the tailcone. The cabin consists of a composite cabin shell with a honeycomb floor and backwall attached to a sheet aluminum subfloor structure which is also referred to as the keel.

2. The backwall and keel structures are attached to a welded steel tubular truss structure called the pylon. The main keel beams are the supporting structure for the cabin and forward landing gear cross tube. The pylon forms the supporting structure for the cabin, fuel

cells, main rotor transmission, engine, aft landing gear cross tube, and the tailcone. The cabin shell is a composite structure, consisting of multiple layers of fiberglass with reinforcing where necessary to add structural stiffness.

## **7-6. Tailcone**

1. The tailcone section is bolted to the aft end of the pylon and extends to the aft end of the helicopter. It is a tapered, semi-monocoque structure comprised of aluminum skins, bulkheads, longerons, and stringers. The tailcone supports the tail rotor transmission, horizontal and vertical stabilizers, and the tail rotor guard. It houses the tail rotor drive shaft, some electronic equipment, and the baggage box.

## **7-7. Landing Gear System**

1. Skid Landing Gear. The main landing gear consists of two tubular aluminum skids attached to the airframe by means of the forward and aft cross tubes through four pivoting legs and four nitrogen-oil oleo struts. The struts cushion ground contact during landing. Drag struts give the gear stability and strength and prevent fore and aft movement during ground contact maneuvers. Replaceable hardened steel skid shoes are installed on each skid to resist skid wear on hard surfaces.

2. Tail Rotor Guard. A tubular tail rotor guard is installed on the aft end of the tailcone. It acts as a warning to the pilot upon an inadvertent tail-low landing and aids in protecting the tail rotor from damage.

3. Ground Handling Wheels. Each landing gear skid tube has provisions for installing ground handling wheel assemblies. Each skid has an adapter plate on which the wheel assemblies attach. Each assembly has a manually operated, over-centering device to lift the skids clear of the ground. The ground handling wheels must be removed before flight.

## **7-8. Cabin**

1. The cabin consists of one pilot seat on the left side of the cockpit, two or three abreast seating in the

rear bench seat and one dual purpose passenger or co-pilot seat on the right front. The aircraft is equipped with a complete set of flight controls at the pilots position and as optional equipment, a set of removable flight controls for the copilots position. The instrument console and radio pedestal are mounted at the forward end of the cabin floor slightly to the left of center.

## **7-9. Cabin Doors**

1. The two cabin doors are composite reinforced structure with transparent Plexiglas windows in the upper section. Ventilation is supplied by the optional sliding panels in the windows. Positive retention door latches are used.

## **7-10. Seats**

1. Pilot and Copilot Seats. The pilot and copilot seats are tracked, adjustable, conventional aircraft seats. The seat includes a lap belt with an inertial reel dual shoulder harness.

2. Rear Passenger Seats. The passenger seats are mounted to the backwall and consist of two honeycomb panels that fold down from the backwall. They are configured with a cushion arrangement for three (3) back seat passengers with individual combination diagonal shoulder harness and lap belt restraints.

3. Front Passenger Seat. The right front crew seat (co-pilot seat) also doubles as a passenger seat when the optional dual controls are removed (para. 7-37). The seat may be left in the seat tracks for the co-pilot position or may be moved over one set of tracks to allow more room for the rear passengers. To move the seat, pull up on both the adjusting lever and the latch handle under the seat base and slide the seat approximately ½" forward or aft until the center posts rest on top of the seat tracks in between holes. At that point, the forward and aft legs will be positioned in the holes so the seat can be lifted straight up and free of the tracks. To re-install the seat, reverse the process.

## NOTE

**The co-pilot seat shall not be moved over to the center (left set of tracks) unless the extended flooring has been installed in the right chin window and the right set of flight controls removed and stowed and the protective covers installed.**

4. The center track of the three on the right side of the cabin is common to both seat installation positions. In the co-pilot position, the center track is the left seat track for the seat. In the staggered passenger position, the center seat track becomes the right seat track for the passenger seat.

5. Inertia Reel Shoulder Harness. An inertia reel and shoulder harness is incorporated in each seat. There is no independent control to manually lock the harness. With the shoulder straps properly adjusted, the reel strap will extend to allow the occupant to lean forward; however, the reel automatically locks when the helicopter encounters an impact force of 2 to 3 "G" deceleration. To release the lock, it is necessary to lean back slightly to release tension on the lock. The shoulder straps must be adjusted properly to prevent rebound overshoot in the event of impact.

## 7-11. Instruments and Controls

1. Instrument Panel. The standard location of controls, indicators, instruments, and data placards installed on the instrument panel is presented in Figure 7-3. The total instrument complement and location may vary depending upon the specific owner specifications and aircraft options.

2. Pedestal Panel. The panels and controls installed in the radio pedestal are presented in Figure 7-4.

3. Other Instruments and Controls. Instruments, controls, and indicators not shown in the above illustrations are shown in the chapter/section which describes their related systems.

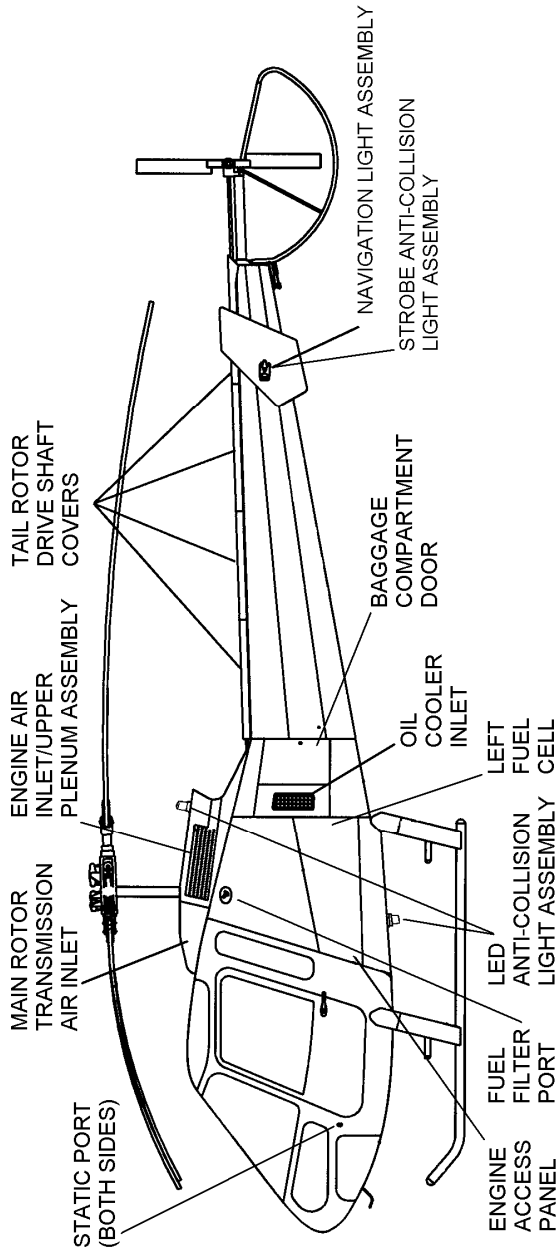

Sheet 1 of 2

Figure 7-1. General Arrangement Diagram

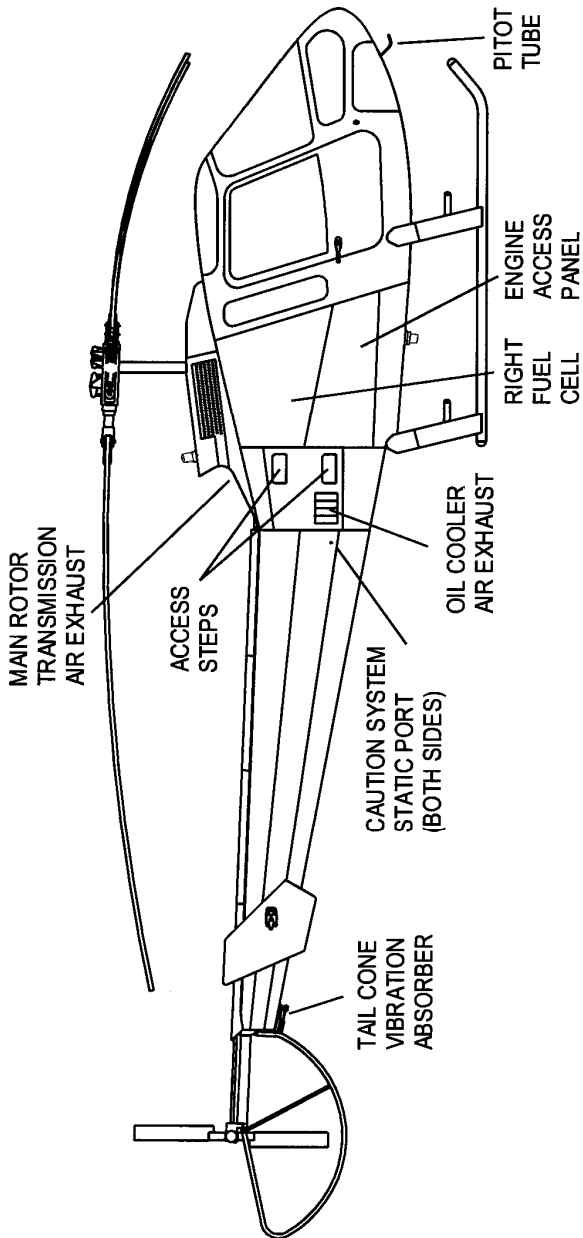

Sheet 2 of 2

Figure 7-1. General Arrangement Diagram

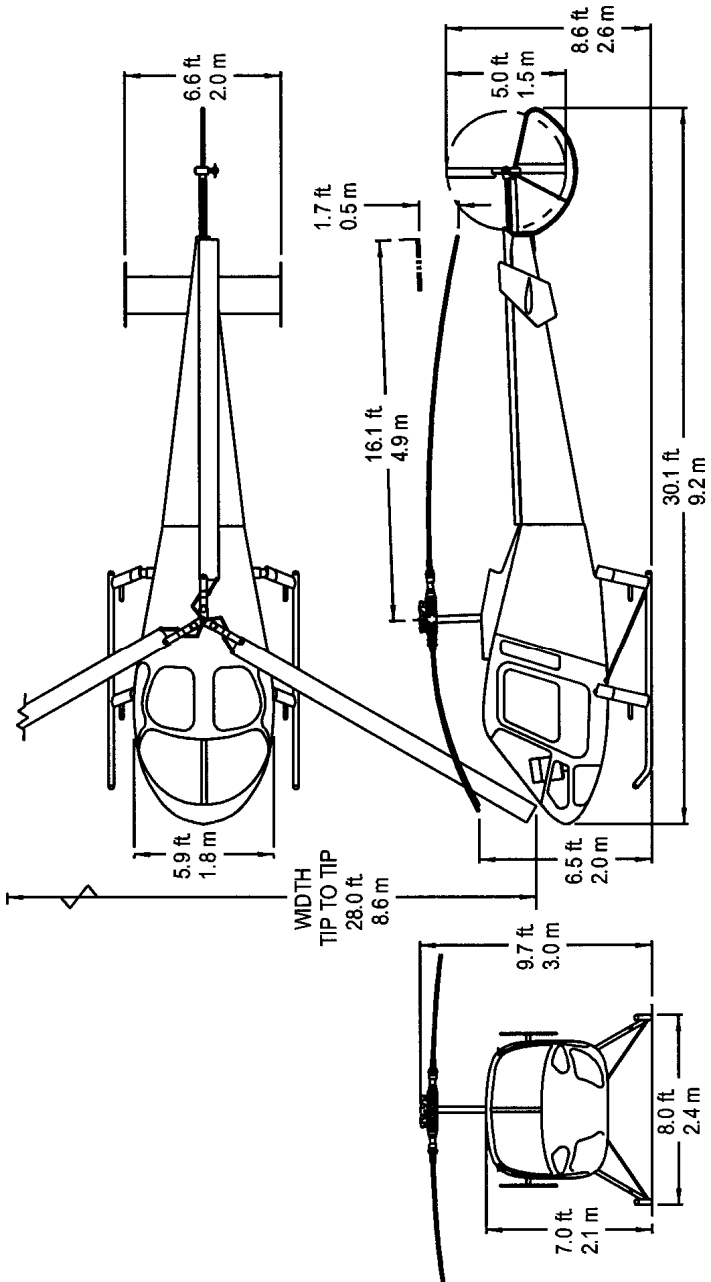
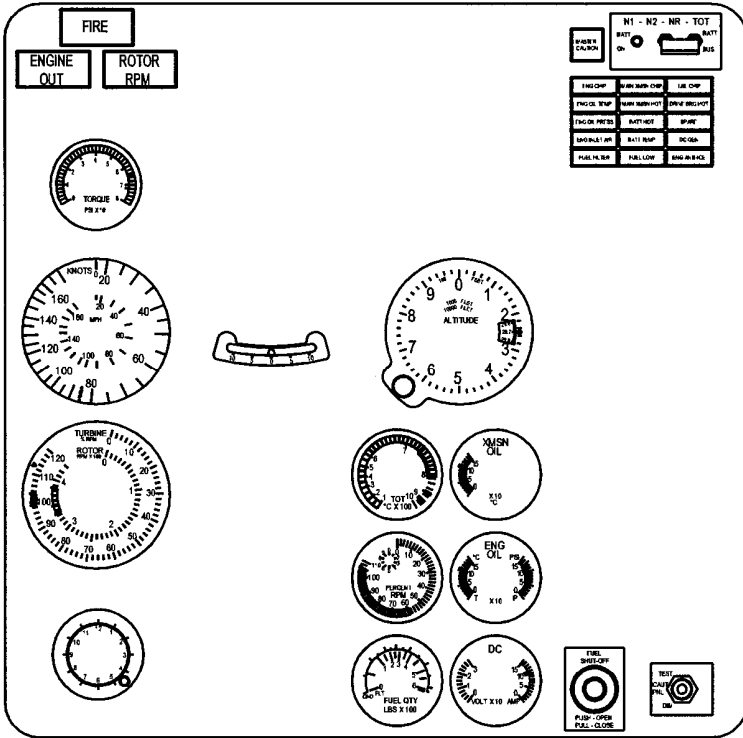

Figure 7-2. Principle Dimensions Diagram



Standard Panel with Standard Instrumentation

S/N: 5039-5045, 5047

Sheet 1 of 4

Figure 7-3. Instrument Panel



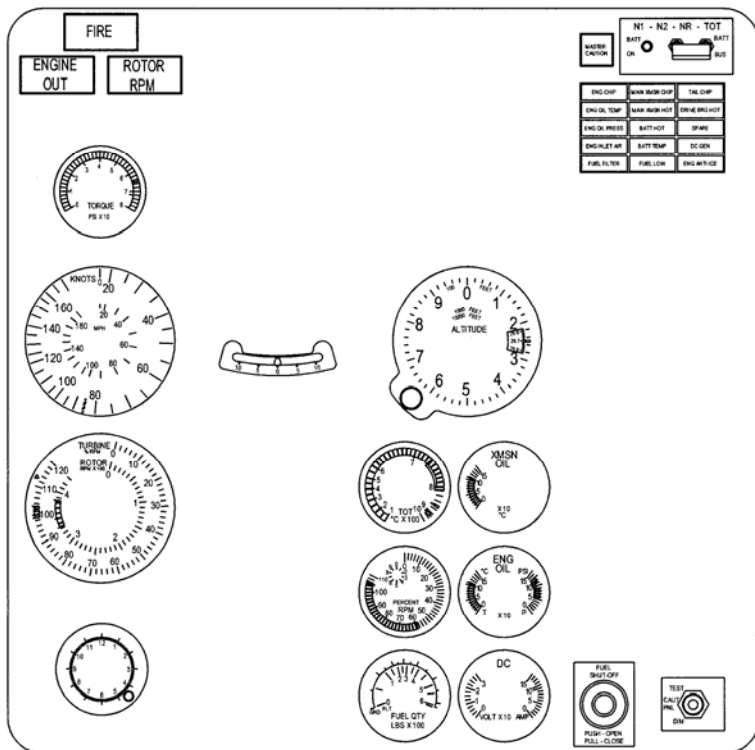

Standard Panel with Standard Instrumentation

S/N: 5046, 5048-5049

Sheet 2 of 4

Figure 7-3. Instrument Panel

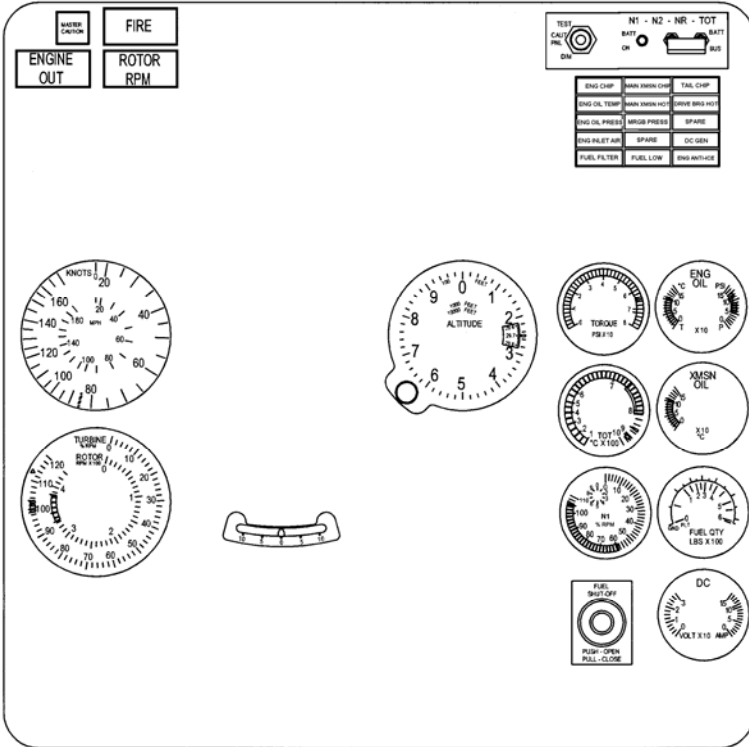

Standard Panel with Standard Instrumentation

S/N: 5050-5135

Sheet 3 of 4

Figure 7-3. Instrument Panel

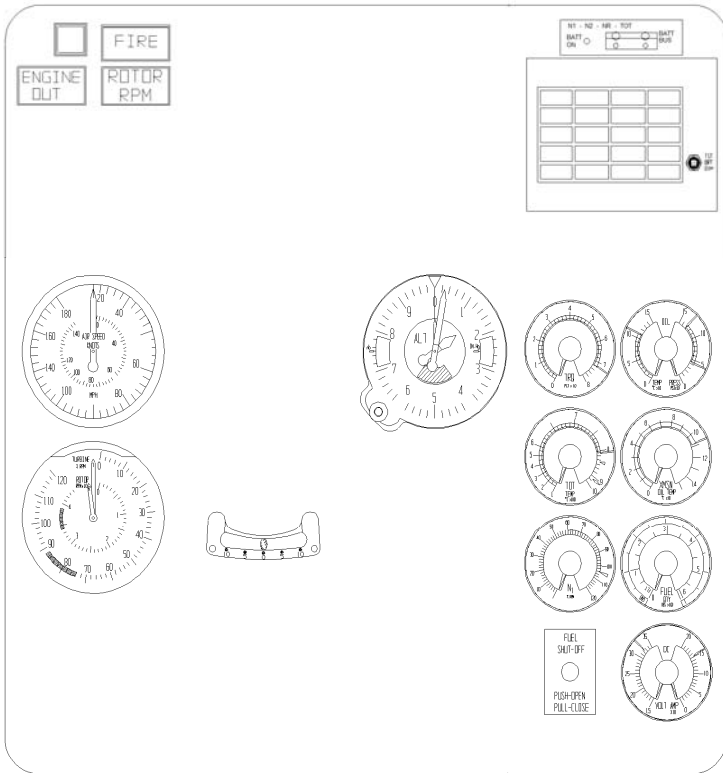

Standard Panel with Standard Instrumentation

S/N: 5136 and subsequent

Sheet 4 of 4

Figure 7-3. Instrument Panel

**INTENTIONALLY LEFT BLANK**

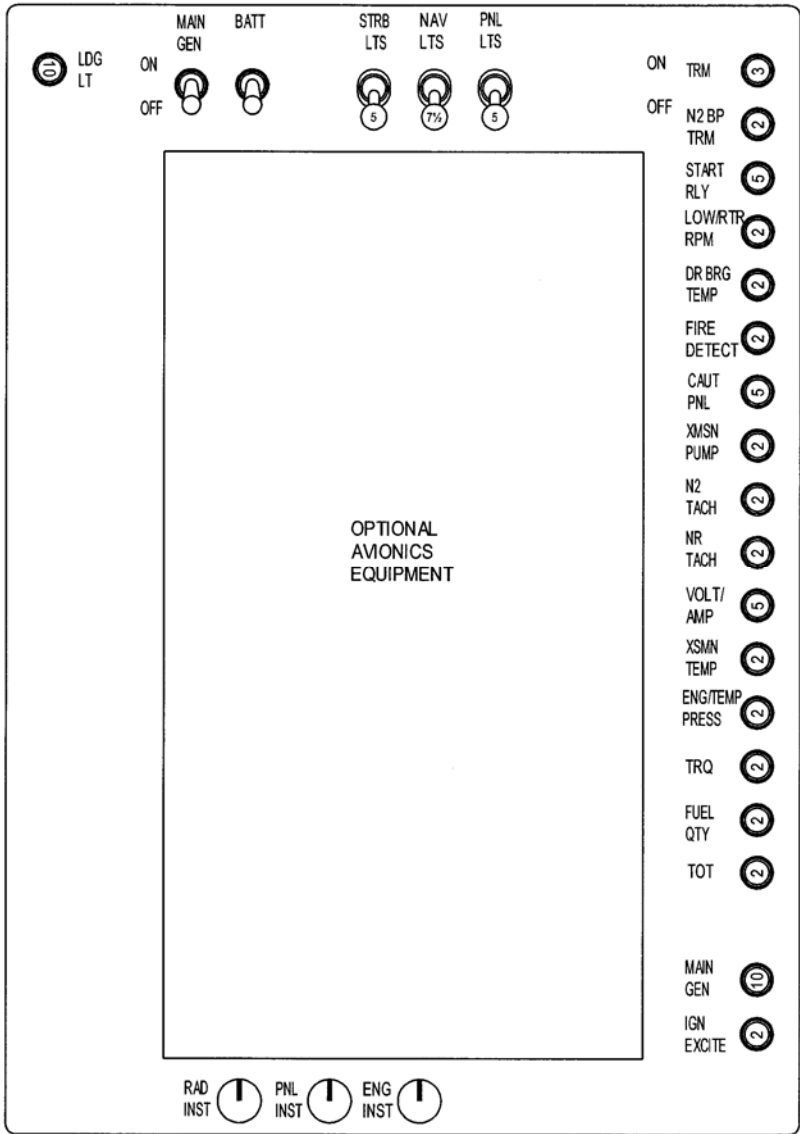

Standard Panel Layout

S/N: 5039-5045, 5047

Sheet 1 of 4

Figure 7-4. Pedestal Panel

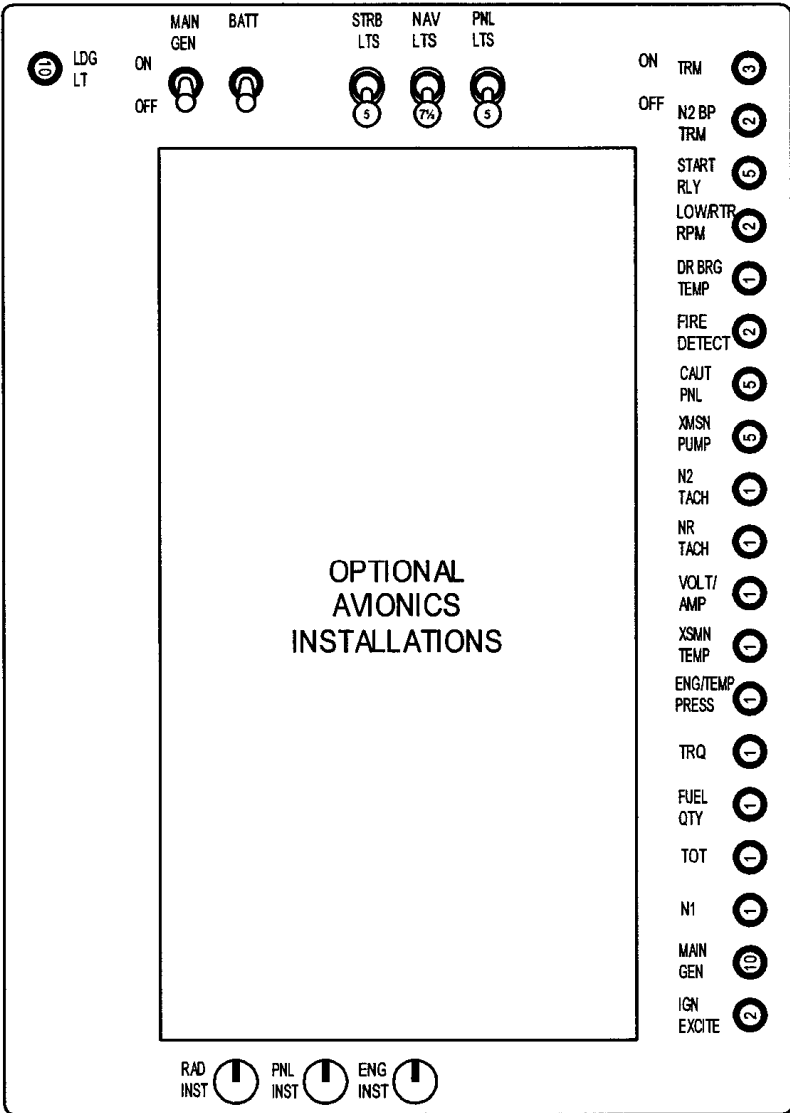

Standard Panel Layout

S/N: 5046, 5048-5076, 5078-5084

Sheet 2 of 4

Figure 7-4. Pedestal Panel

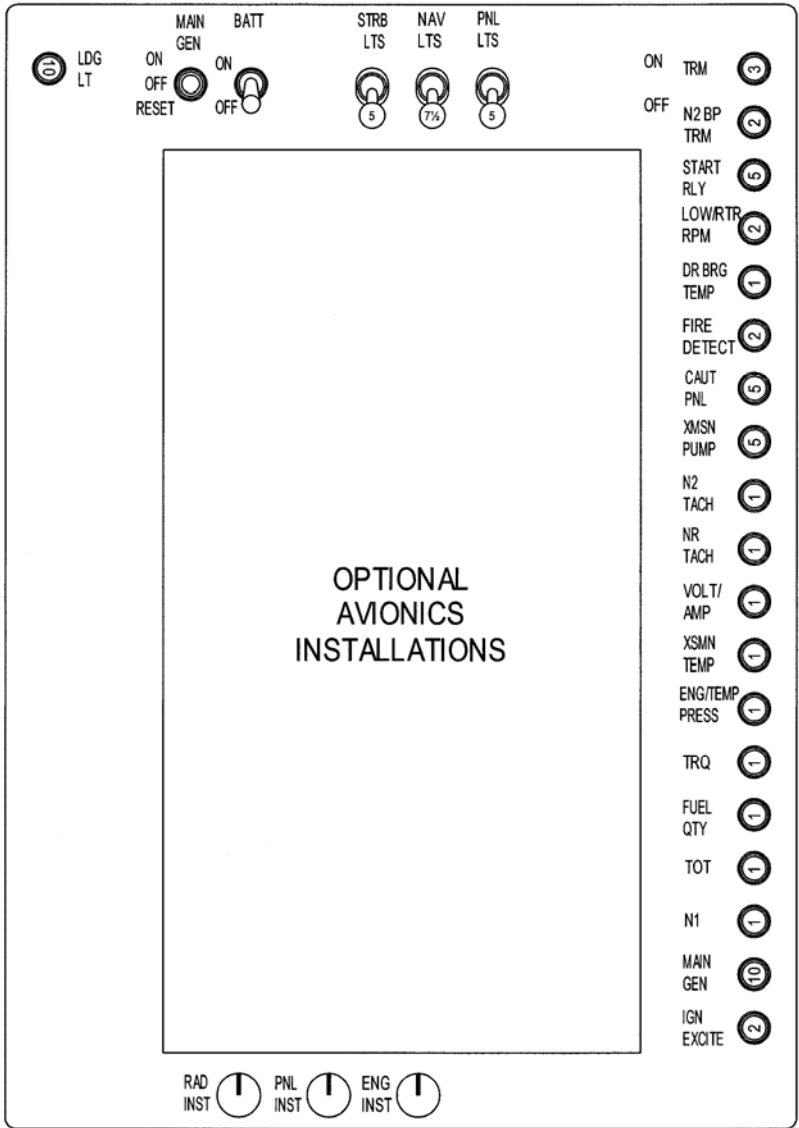

Standard Panel Layout

S/N: 5077, 5085-5133

Sheet 3 of 4

Figure 7-4. Pedestal Panel

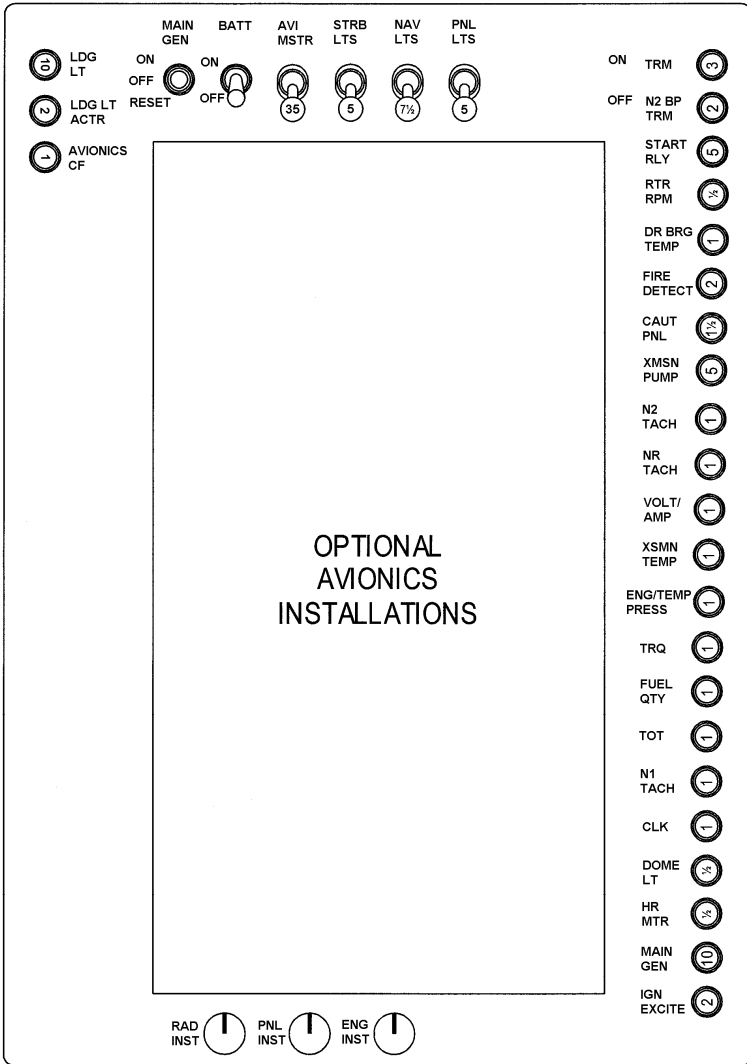

Standard Panel Layout

S/N: 5134 and Subsequent  
 Sheet 4 of 4

Figure 7-4. Pedestal Panel



**INTENTIONALLY LEFT BLANK**

## SECTION II. EMERGENCY EQUIPMENT

### 7-12. Aircraft Fire Detection System

1. General. The 480B is equipped with a Systron Donner fire detection system consisting of a test switch, a fire/overheat detector, and a red **FIRE** warning light on the instrument panel. The system provides the flight crew with the necessary warning of fire or excessive overheat in either the upper or lower engine compartments. The system is powered by the aircraft 28-volt electrical system and is protected by the **FIRE DET** or **FIRE DETECT** circuit breaker.

2. Fire/Overheat Detector System. The aircraft is equipped with a Systron Donner model 801-DRH pneumatically operated fire/overheat detector system. The System consists of a sensor tube, a responder assembly, and separate test and annunciator circuits. The detector sensor tube contains helium gas under a preset pressure and a hydrogen charged core material. The application of heat to the sensor causes an increase in internal gas pressure which in turn operates a pressure diaphragm within the responder assembly that closes an electrical contact activating the red cockpit **FIRE** warning light at the top of the instrument panel. The pressure diaphragm within the responder assembly serves as one side of the electrical contact and is the only moving part in the detector. Mechanical damage to the pneumatic detector's sensor tube cannot result in a false alarm. Any severe damage or deterioration to the unit will provide a "no test", not a false alarm. Also, because of the action of an electrical shunt plate installed at the mating face of the responder connector, the intrusion of conducting fluids into the electrical connector cannot cause a false alarm.

- a. Averaging and Discrete Sensing Functions. The detector has two sensing functions. It responds to an overall "average" temperature threshold or to a highly localized "discrete" temperature caused by impinging flame or hot gasses. Both the "average" and "discrete" temperatures are factory set and cannot be changed in the field. Both the averaging and the discrete functions are

reversible. When the sensor tube is cooled, the pressure is lowered and the reduction of internal pressure allows the alarm switch to return to its normal position thus opening the electrical alarm circuit.

- b. **Detector Test Function.** In addition to the pressure activated alarm switch, there is a second switch in the detector which is held closed by the averaging gas pressure at all temperatures down to  $-65^{\circ}\text{F}/-54^{\circ}\text{C}$ . If the detector should develop a leak, the loss of gas pressure would allow the integrity switch to open and signal a lack of detector integrity by inhibiting the test function. The crew may test the detector system by pressing the Caution Panel test switch down and holding it. A lack of detector integrity would prevent the **FIRE** warning light from activating. A properly functioning system will be annunciated by the **FIRE** warning light on the instrument panel illuminating as long as the test switch is held. The detector sensor will withstand a  $2012^{\circ}\text{F}/1100^{\circ}\text{C}$  direct flame without deterioration for 5 minutes.

### **7-13. Optional Portable Fire Extinguisher**

1. The aircraft may be equipped with an optional portable fire extinguisher. The fire extinguisher is carried in a bracket located on the floor to the left of the pilot seat.

### **7-14. Optional First Aid Kit**

1. The aircraft may be equipped with an optional general purpose first aid kit.

## SECTION III. ENGINE AND RELATED SYSTEMS

### 7-15. Engine

1. The 480B is equipped with a Rolls-Royce 250-C20W free turbine, turboshaft engine rated at 420 SHP/313 kW but limited in this installation to 305 SHP/227 kW for a five minute takeoff rating, and 277 SHP/206 kW for maximum continuous operation. The engine is installed in compressor aft, exhaust down orientation.

### 7-16. Engine Components

1. The engine consists of four sections: the compressor section, the combustion section, the turbine section, and the power and accessory gearbox.

2. Compressor Section. Air enters the engine through the compressor inlet and is compressed by six axial and one centrifugal compressor stages. The compressed air is discharged through the scroll-type diffuser into two external air ducts which direct the air to the combustion section.

3. Combustion Section. The engine has a single combustion chamber. Air from the compressor discharge tubes enters the single combustion chamber at the forward end of the engine. The air is mixed with fuel sprayed from the fuel nozzle and the combustion takes place. Combustion gasses move aft out of the chamber to the turbine section.

4. Turbine Section. The turbine section is mounted between the combustion section and the power and accessory gearbox and consists of a two stage gas producer turbine and a separate two stage power turbine. The gas producer turbine drives the compressor and a portion of the accessory gear train while the power turbine furnishes the output power of the engine through the power gear train and also drives a portion of the accessory gear train. The hot exhaust gases discharge downward through twin ducts in the turbine and exhaust collector support.

5. Power and Accessory Gearbox. The main power and accessory drive gear trains are enclosed in a single gear case. The gear case serves as the structural support of the engine. All engine components, including the engine mounted accessories are attached to the case. Accessories driven by the power turbine gear train are the power turbine ( $N_2$ ) tachometer generator and the power turbine governor. The gas producer gear train drives the compressor, fuel pump, gas producer ( $N_1$ ) tachometer generator, gas producer fuel control, pressure and scavenge oil pumps, and the starter-generator.

### 7-17. Engine Compartment Cooling

1. The engine compartment is cooled by natural convection augmented by a fan integral to the upper drive pulley.

2. Aircraft serial number 5114 and subsequent are equipped with fuselage panels/cowls that have additional holes to increase the cooling efficiency of the engine compartment and can be equipped with Engine Access Panels, P/N 4220150-3/-4, to allow aircraft operation at an increased maximum ambient temperature limit. Serial numbers 5087 through 5113 can be equipped with the Increased Cooling Kit, P/N 4230031, for operation at the increased maximum ambient temperature limit. Refer to paragraph 1-15 for the increased maximum ambient temperature limit for properly equipped aircraft.

### 7-18. Air Induction System

1. The aircraft is equipped with dual full flow swirl tube inertial type particle separators. Particle laden air is directed into the upper plenum chamber through a series of swirl tubes which impart a centrifugal spin to the air as it enters the tubes, thereby inertially separating the heavier foreign matter. The particulate matter falls down into a collector and is then purged overboard through one of two bleed air driven venturi-type ejectors that exit at the aft face of the upper plenum. The scavenge ejectors are manually controlled by the **SCAV AIR** control located in the control panel mounted on the aft side of the center pedestal. During takeoff, hovering, or cruise operations in dusty atmospheric conditions, the scavenge ejectors can be turned on by moving the **SCAV AIR** control to the **ON** position (Figure 7-5).

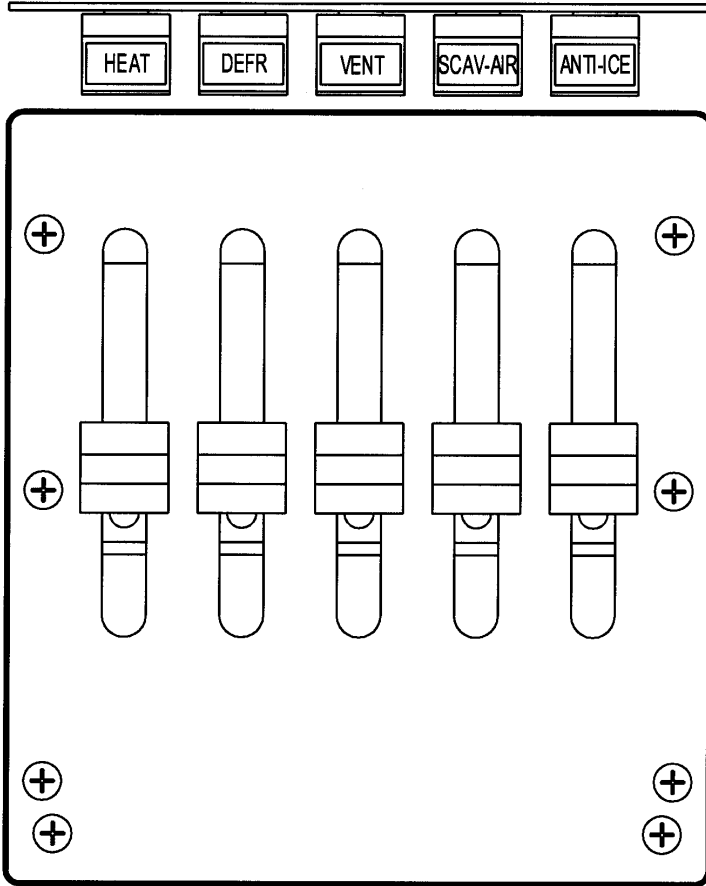

## NOTES

1. MOVE CONTROL UP FOR "ON" AND DOWN FOR "OFF"
2. "HEAT", "DEFR", AND "VENT" ARE OPTIONAL EQUIPMENT. LOCATION OF "SCAV-AIR" AND "ANTI-ICE" MAY VARY DEPENDING ON CUSTOMER SPECIFICATION.

Figure 7-5. Slide Control Panel

## 7-19. Engine Inlet Air Caution Light

1. The **ENG INLET AIR** caution light is a part of the caution panel and will illuminate any time there is a pressure drop of at least 0.5 psi/7 kPa across the inlet indicating that there is a partial blockage of the particle separator. This caution light is activated by a differential pressure switch which senses air pressure in the lower plenum and compares it to reference pressure at static ports on either side of the tailcone. Pilot action required when this caution light illuminates is discussed in Chapter 3, Emergency Procedures, of this manual.

## 7-20. Engine Inlet Anti-Icing System

1. The compressor inlet guide vanes and the front bearing support hub are the only engine components with anti-icing provisions. Anti-icing is provided by the use of compressor bleed air. Anti-icing is activated by moving the **ANTI-ICE** control, located in the control panel on the aft side of the center pedestal, to the **ON** position (Figure 7-5).

## 7-21. Engine Fuel Control

1. The 250-C20W engine is equipped with a Bendix/Honeywell fuel control system. The system controls engine power output by controlling the gas producer speed. Gas producer speed levels are established by the action of the power turbine governor which senses power turbine speed. The power turbine speed (load) is selected by the operator and the power to maintain this speed is automatically maintained by power turbine governor action on metered fuel flow. The power turbine governor lever schedules the power turbine governor requirements. The power turbine governor in turn, schedules the gas producer speed in reference to a power output change to maintain output shaft speed.

2. Throttle. The throttle is a twist grip type on the collective flight control. The throttle is rotated to the left to increase or to the right to decrease power.

3. Engine Idle Release Control. The engine idle release (idle release) is configured one of two ways. For aircraft S/N 5136 and subsequent, the engine idle release is activated from either pilot or copilot collective by pressing the **IDLE STOP** release switch on the collective control head. The idle stop is operated by a solenoid based, electrically controlled stop mechanism and is powered by the **IDLE STOP** circuit breaker (5 amp, ref. Figure 7-11) directly from the battery. The circuit breaker is located under the APU plug in the engine compartment. The idle stop will operate whether the master switch is in the ON or OFF position. For earlier aircraft, the engine idle release is a spring loaded plunger mounted in the switch box on the pilot's collective only. The engine idle release prevents the pilot from accidentally retarding the throttle beyond the engine idle position preventing inadvertent engine shutdown. The engine idle release need not be pressed when performing engine start or run-up; however, the engine idle release must be activated when accomplishing an engine shutdown.

4. Governor RPM Beep Trim Switch. The **GOV INCR/DECR** switch is mounted in the switch box on both the pilot's and the copilot's (optional dual controls) collective controls. The switch is a three position momentary type. The switch must be held in the forward (**INCR**) position to increase the power turbine ( $N_2$ ) speed or in the aft (**DECR**) position to decrease the power turbine ( $N_2$ ) speed. Regulated power turbine speed may be adjusted in flight through the operating range by movement of the switch as required. Electrical power for circuit operation is supplied by the 28-volt electrical system.

5. Gas Producer Fuel Control. The Bendix/ Honeywell gas producer fuel control has a bypass valve, metering valve, acceleration bellows, governing and enrichment bellows, manually operated cutoff valve, maximum pressure relief valve, a torque tube seal and lever assembly and a start derichment valve. The maximum pressure relief valve is incorporated to protect the system from excessive fuel pressure. Fuel enters the control from the engine driven fuel pump and filter



assembly and is directed to the metering valve. The metering valve is operated by lever action through movement of the governor and acceleration bellows. The start derichment valve is only open during light-off and acceleration to idle. Gas producer speed is controlled by the gas producer fuel control governor. The governor reset section of the gas producer fuel control; however, permits the power turbine governor to override the speed governing elements of the fuel control to alter the fuel schedule in response to changing load conditions applied to the power turbine. The start/acceleration control is provided as an adjustable control to allow maintenance personnel and operators to adjust the start cycle for altitude or temperature.

6. Power Turbine Governor. The power turbine speed is scheduled by the power turbine governor lever and the power turbine speed scheduling cam. The cam sets a governor spring load which opposes a speed-weight output. The overspeed protection of the compound power turbine governor becomes effective at approximately 108%  $N_2$ .

7. Fuel Pump and Filter Assembly. The Rolls-Royce 250-C20W incorporates a single gear-type pump element, a low pressure barrier filter and a filter bypass valve. Fuel enters the engine fuel system at the inlet port of the pump and passes through the low pressure filter before entering the gear element. The filter bypass valve allows fuel to bypass the filter element if it becomes clogged. The bypass return flow from the fuel control is passed back to the inlet of the gear element. Through passages leading to auxiliary filling ports on the periphery of the gear element, a portion of the bypass flow fills the gear teeth when vapor-liquid conditions exist at the inlet to the gear element. The paper filter is located inside the fuel pump assembly upstream of the gear element. It is located in a cast cover attached to the pump housing by two socket head cap screws. The cover is located on the front of the pump.

8. Fuel Nozzle. The fuel nozzle is a single-entry dual-orifice type unit which contains an integral valve for

dividing primary and secondary flow. This same valve acts as a fuel shutoff valve when the fuel manifold pressure falls below a predetermined pressure, thus keeping fuel out of the combustion chamber at shutdown.

## 7-22. Fuel Filter Caution Light

1. A fuel filter differential pressure switch is installed at the fuel filter element to measure filter pressure drop. When the pressure drop exceeds 1.3 PSI/9 kPa, the switch will activate the **FUEL FILTER** caution light on the caution panel to alert the pilot to impending filter bypass. Pilot action when this light is illuminated is addressed in Chapter 3, Emergency Procedures.

## 7-23. Turbine Outlet Temperature (TOT) Measurement System

1. The TOT measurement system consists of four chromel-alumel, single junction thermocouples in the gas producer turbine outlet with an integral terminal. The voltages of the four thermocouples are electrically averaged in the assembly and delivered by the assembly lead to the airframe terminal block for reference to the temperature indicating system.

## 7-24. Compressor Bleed Air System

1. The 5th stage bleed air system permits rapid engine response. The system consists of a compressor discharge pressure sensing port on the scroll, tubing from the sensing port to the bleed valve, a compressor bleed control valve and a bleed air manifold on the compressor case. An annular slot over the 5th stage blades bleeds compressor air into a manifold which is an integral part of the compressor case. The manifold forms the mounting flange for the compressor bleed control valve when the compressor case halves are assembled. Compressor discharge air pressure sensing for bleed control valve operation is obtained at a sensing port on the compressor scroll. The bleed control valve is normally open until 73%  $N_1$  and is closed by compressor discharge pressure slowly

until reaching fully closed at approximately 93%  $N_1$  at sea level standard conditions. The values where the bleed air valve starts to close and is fully closed will vary with altitude and temperature.

## 7-25. Ignition and Start System

1. The starter switch, located in the switch box on the pilot's and copilot's collective is a pushbutton type switch. When the switch is pressed, the circuit to the starter relay actuating coil and the igniter unit are energized. The switch is released when the engine starts or the starter time limit expires. The circuit is protected by the **START RLY** and **IGN EXCITE** circuit breakers. For aircraft S/N 5135 and earlier, the starter switch is located in the switch box on the pilot's collective only.

## 7-26. Engine Oil Supply

1. The lubrication system is a circulating dry sump type with an external reservoir, scavenge filter, and heat exchanger. A gear-type pressure and scavenge pump assembly is mounted within the gearbox. The oil filter, filter bypass valve, and pressure regulating valve are located in the lower right hand side of the gearbox housing and are accessible from the bottom of the engine. The engine oil tank is located on the right side of the aircraft in the upper engine compartment where it is easily accessible for preflight and servicing through the right hand engine access panel. The tank has a capacity of 6 quarts/5.7 liters. The engine oil cooler (heat exchanger) is upstream of the reservoir. The oil passes through the oil cooler and is cooled by air supplied by a high volume oil cooler blower. An external scavenge oil filter is installed between the oil cooler and the engine. All engine oil system lines and connections are internal except the pressure and scavenge lines to the front compressor bearing and the bearings in the gas producer and power turbine supports.

## 7-27. Engine Chip Caution Light

1. Magnetic chip detectors are installed at the bottom of the gearbox and at the engine oil outlet

connection. The chip detectors are non-fuzz burning, connected in parallel, and incorporate a Programmable Continuity Sensor (PCS). Any time power is applied to the caution panel or the caution panel test switch is pressed and held for at least 3 seconds, the PCS will go through a 5 second continuity check to ensure that the circuit is complete. During that time, the **ENG CHIP** caution light will remain illuminated then extinguish. If there is a break anywhere in the circuit the caution light will not respond to the 5 second test. During normal operation, any chip detected on either plug will activate the **ENG CHIP** caution light on the caution panel.

## 7-28. Engine Instruments and Indicators

1. The engine instruments and indicators are mounted in the instrument panel or the caution panel. The pointer of each indicator will be at the “park” position until power is turned on. Once the system is powered, each indicator pointer will move from the “park” position to the current input signal for that indicator. Earlier aircraft may be equipped with indicators that perform a power-on self-test sequence (Refer to paragraph 7-28.9).

2. Engine Out Warning. The caution panel logic circuit senses the output from the gas producer ( $N_1$ ) tachometer generator. Power is supplied through the **CAUT PNL** circuit breaker and connections are made to the **ENGINE OUT** warning light and to a tone generator which produces an oscillating tone. The warning system is activated until the  $N_1$  reaches  $58\% \pm 1\%$  and is deactivated when the gas producer speed is above that value. The engine out audio is distinctly different from the low rotor audio and when activated the engine out audio tone generator produces an oscillating warble tone.

3. Audio Warning Microswitch. An audio warning microswitch is installed in the collective control system. This switch enables the pilot to disable the audio signal by lowering the collective to the full down position. The audio microswitch is located at the base of the pilot's collective on the collective torque tube.

4. Torque Indicator. The engine torque indicator (**TRQ**), located in the instrument panel, is a micro-

processor based indicator which uses the signal from an engine mounted pressure transducer to indicate engine power. The indicator is powered by the aircraft 28-volt electrical system through the **TORQUE** or **TRQ** circuit breaker. The indicator's microprocessor continuously monitors "sensor reasonableness" and for some earlier aircraft, may perform a power-on self-test (Refer to para. 7-28.9). The micro-processor in the indicator will illuminate the LED RED when the maximum torque limit is exceeded (Refer to para. 7-76.2.c).

**NOTE**

**Early 480B's are not equipped with the microprocessor based indicator.**

5. Turbine Outlet Temperature (TOT) Indicator. The **TOT** indicator, which is powered by the aircraft 28-volt electrical system through the **TOT** circuit breaker, is a microprocessor based indicator and uses the DC voltage from the thermocouple harness to indicate turbine outlet temperature. The indicator's microprocessor continuously monitors "sensor reasonableness" and for some earlier aircraft, may perform a power-on self-test (Refer to para. 7-28.9). The microprocessor in the indicator will illuminate the LED RED when the maximum TOT limits are exceeded (Refer to para. 7-76.2.c). The indicator will not operate without 28-volt electrical power. In the event of a main electrical bus failure, the instrument can be driven directly from the aircraft battery by moving the **N1-N2-NR-TOT** switch from **BUS** to **BATT**.

**NOTE**

**Early 480B's are not equipped with the microprocessor based indicator.**

6. Gas Producer Tachometer. The gas producer tachometer (**N1**), located in the instrument panel, is a microprocessor based indicator and uses the AC voltage produced by the gas producer tachometer generator to indicate the gas producer turbine speed (**N1**) in terms of

percent RPM. The indicator's microprocessor continuously monitors "sensor reasonableness" and for some earlier aircraft, may perform a power-on self-test (Refer to para. 7-28.9). The micro-processor in the indicator will illuminate the LED RED when the maximum  $N_1$  limits are exceeded (Refer to para. 7-76.2.c). The tachometer, powered by the aircraft 28-volt electrical system through the **N1 TACH** circuit breaker, requires 28 VDC for operation. In the event of a main electrical bus failure, the instrument can be driven directly from the aircraft battery by moving the **N1-N2-NR-TOT** switch from **BUS** to **BATT**.

#### NOTE

**Early 480B's are equipped with a gas producer tachometer which directly uses the AC voltage from the tachometer generator to drive the tachometer. The gas producer tachometer system in these aircraft does not require aircraft electrical power for operation.**

7. Power Turbine Tachometer. The power turbine tachometer (**TURBINE**) is a part of the dual tachometer indicator located on the instrument panel. The indicator, powered by the aircraft 28-volt electrical system through the **N2 TACH** circuit breaker, is driven by a servo motor which uses AC voltage generated by a tachometer generator. The frequency of the AC voltage is a function of the power turbine speed ( $N_2$ ). The servo motor positions the power turbine RPM pointer (marked "**T**") to indicate the percent RPM of the power turbine on the outer scale of the dual tachometer indicator. This system requires 28 VDC for operation. In the event of a main electrical bus failure, the instrument can be driven directly from the aircraft battery by moving the **N1-N2-NR-TOT** switch from **BUS** to **BATT**.

8. Engine Oil Temperature/Pressure Indicator. The engine oil temp/press indicator (**OIL**) is a microprocessor based indicator. Engine oil pressure (**PRESS**) is displayed on the right half of the oil pressure/temperature indicator located on the instrument panel. The oil pressure display is driven by an engine mounted oil pressure transducer.

Engine oil temperature (**TEMP**) is displayed on the left half of the indicator and is driven by a temperature probe at the engine oil tank outlet. The indicator's microprocessor continuously monitors "sensor reasonableness" and for some earlier aircraft, may perform a power-on self-test (Refer to para. 7-28.9). The micro-processor in the indicator will illuminate the LED RED when the operating limits for engine oil temperature and/or pressure are exceeded (Refer to para. 7-76.2.c). The indicator is powered by the aircraft 28-volt electrical system through the **ENG/TEMP PRESS** circuit breaker.

#### NOTE

**Early 480B's are not equipped with the microprocessor based indicator.**

9. Power-On Self-Tests. The TORQUE, TOT, ENGINE OIL TEMP/PRESS, and the GAS PRODUCER (N<sub>1</sub>) TACHOMETER indicators are microprocessor based indicators. For some earlier aircraft, these indicators may perform a power-on self-test when power is supplied to the indicator. During the self-test, the LED on the indicator face illuminates RED as the pointer moves from the "park" position to the maximum indication. The LED will change to GREEN during the pointer movement. When the pointer reaches the maximum indication, the LED extinguishes and the pointer returns to the "park" position, and then it indicates the current input signal for the indicator. If the self-test fails, the LED indicator flashes RED at a 2 Hz rate for approximately 30 seconds and the pointer moves to the "park" position. The self-test will occur anytime power is disconnected from the indicator for more than 5 seconds. The microprocessor also continuously monitors "sensor reasonableness." If the microprocessor senses an input that exceeds the predefined "reasonable" limits (limits outside of the normal minimum and maximum limits), the LED indicator flashes RED at a 4 Hz rate for approximately 30 seconds and the pointer moves to the "park" position.

10. Caution Lights.
  - a. The **ENG INLET** caution light is discussed in the air induction system section, paragraph 7-19.
  - b. The **FUEL FILTER** caution light is discussed in the paragraph 7-22.
  - c. The **ENG CHIP** caution light is discussed in paragraph 7-27.
  - d. The **ENG OIL TEMP** caution light will illuminate when the engine oil temperature reaches 107°C ascending and will extinguish at 100°C descending. A set of contact closures in the dual engine oil temperature/pressure indicator send a signal to the caution panel logic circuit at each of the above set points to turn the caution light either on or off accordingly.
  - e. The **ENG OIL PRESS** caution light will illuminate if the  $N_1$  is above 78.5% and the oil pressure is at or below 88 psig. The light will extinguish as the pressure rises above 90 psig with the  $N_1$  above 78.5%.
  - f. The microprocessor in the TORQUE, TOT, ENGINE OIL TEMP/PRESS, and the GAS PRODUCER (N1) TACHOMETER indicators will illuminate the LED RED when an operating limitation is exceeded. The LED will extinguish when the indication is within normal operating limitations. Depending on which operating limitation is exceeded, the illuminated LED may or may not have a corresponding indication with the Caution and Warning Systems (Refer to para. 7-76.2.c).

#### NOTE

**Early 480B's are not equipped with the microprocessor based indicators.**



## SECTION IV. FUEL SYSTEM

### 7-29. Fuel System

1. The 480B is equipped with fuel bladders designed to retain fuel in a crash. The fuel bladders are filled with open cell foam panels which prevent the bladders from collapsing and to prevent fuel sloshing as the aircraft attitude is changed. The fuel bladders have a total fuel capacity of 90 gallons/340 liters, with a total of 1.7 gallons unusable fuel, 0.85 gallon/3.2 liter unusable fuel in each tank. The simplified fuel system diagram (Figure 7-6) consists of two 45 gallon/170 liter bladder type fuel cells mounted either side of the main rotor transmission. Each bladder is housed in a composite fuel cell structure and is interconnected to the other bladder through a 2.0 inch/5.1 cm cross-feed line in the lower 1/3 of the fuel cell and a 0.5 inch/1.3 cm overboard vent line. A 0.75 inch/1.9 cm main fuel feed line from the lowest point in each bladder interconnects through the main fuel shutoff valve in a "tee" to provide the fuel to the engine equally from each cell. The main fuel shutoff valve is a ball type valve manually operated from the cockpit. It is activated by pushing the center button in and holding it in while pulling the knob fully out until it stops, approximately a 4 inch/10 cm pull. Each fuel cell is equipped with sump drains plus the system is equipped with a low point drain before the fuel enters the engine. The capacitance fuel quantity probe is mounted in the right hand fuel cell. The fuel filler cap is located in the top of the left hand fuel cell. The right hand cell is filled by cross-feeding action during gravity refueling.

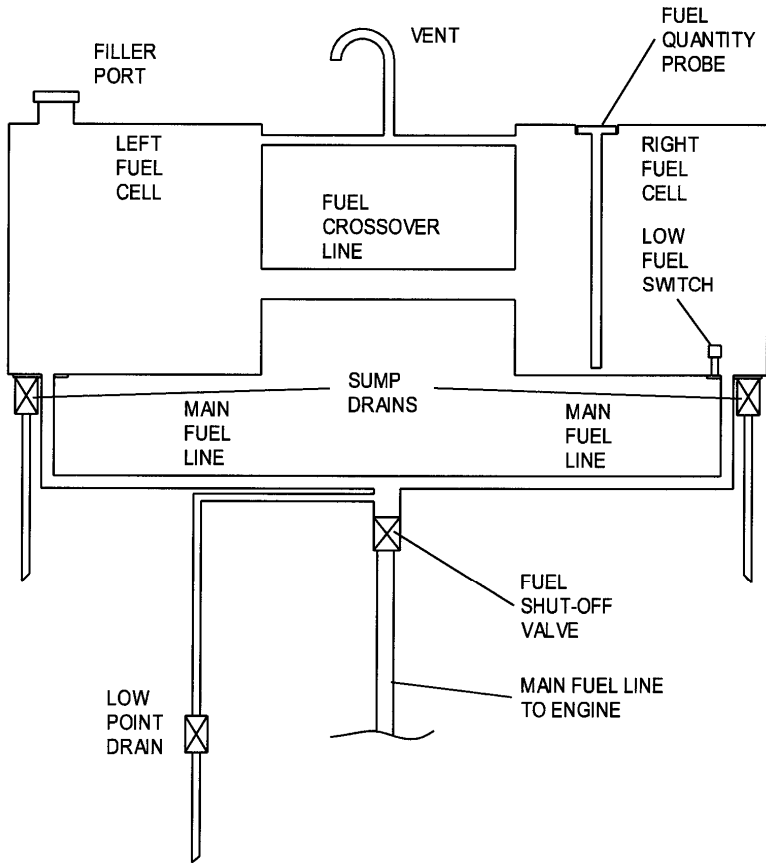

Figure 7-6. Fuel System Diagram

## 7-30. Fuel Quantity System

1. Capacitance Probe. The capacitance probe, located in the right fuel cell, senses actual fuel quantity in the fuel cell by measuring the height of the fuel electronically.

2. Fuel Quantity Indicator. The fuel quantity indicator (**FUEL QTY**), located in the instrument panel, is a microprocessor based indicator that uses the signal from the capacitance probe to indicate total fuel quantity in the fuel cells. The indicator assumes there is an equal amount of fuel in each fuel cell. The indicator and capacitance probe are powered by the aircraft 28-volt electrical system through the **FUEL QTY** circuit breaker. The indicator's microprocessor performs a power-on self-test when power is connected to the indicator and also continuously monitors "sensor reasonableness" (Refer to para. 7-28.9). The microprocessor in the indicator will illuminate the LED RED when there is less than 35 lbs/16 Kg of fuel in the cells. The fuel quantity indicator LED low fuel indication is independent of the Low Fuel Float Switch in the aircraft Caution and Warning System.

### NOTE

**Early 480B's are not equipped with the microprocessor based indicator.**

### NOTE

**The fuel quantity indicator is the primary source of fuel quantity information because it is a direct reading gage from the capacitance probe. If there is a discrepancy between the fuel quantity indicator and the optional fuel management system, the pilot should rely only on the fuel quantity indicator.**

3. Low Fuel Caution Light. The low fuel caution light system consists of a float switch located near the capacitance fuel quantity probe. This switch activates the

**LOW FUEL** light in the caution panel when there are approximately 5 gallons/19 liters of fuel remaining.

### 7-31. Fuel Management System

1. General. The optional fuel management system consists of a fuel flow transducer and cockpit display unit. In addition to displaying the calculated fuel quantity in pounds, the system displays instantaneous fuel flow in pounds per hour, displays instantaneous endurance in terms of hours and minutes of flight time available at the current fuel flow, and displays fuel consumed in pounds. Additionally, if an optional GPS system is installed, the fuel management system can provide the GPS system with real time fuel flow and fuel remaining through a serial port.

#### NOTE

**Refer to the GPS Operation Manual for the system functions, capabilities, and operating instructions.**

2. Cockpit Display Unit. The cockpit display unit is mounted in the instrument panel and consists of a six-segment digital display. The left three segments of the display are dedicated to fuel flow in pounds per hour based on 6.7 lb/gallon fuel density. The right-most three segments are switchable between displaying fuel endurance in hours and minutes, based on current fuel flow or fuel remaining, or fuel used in pounds.

#### NOTE

**The total fuel quantity in the fuel management system display is not automatically sensed by a fuel quantity probe; it must be manually entered at each refueling by noting the quantity displayed on the fuel quantity indicator.**

## SECTION V. FLIGHT CONTROLS

### 7-32. Flight Controls

1. The flight controls include three primary systems: the collective, cyclic, and anti-torque (tail rotor) controls. The aircraft also has fixed horizontal and vertical stabilizers mounted on the tailcone to provide additional stability and attitude control during high speed flight.

### 7-33. Collective Pitch Control System

#### NOTE

**Prior to aircraft S/N 5136 only the pilot's collective was equipped with engine start and idle stop release controls. On S/N 5136 and subsequent, both the pilot's and copilot's collectives have identical engine controls.**

1. The collective pitch control system includes optional dual collective controls mechanically interconnected and linked to the main rotor swashplate through a series of push-pull tubes, a torque tube, bellcranks, and a collective walking beam at the base of the main rotor transmission. Both collective controls have interconnected twist grip throttles installed at the forward end of the control stick and each has a switch box mounted forward of the throttle (Figure 7-7). Both collectives incorporate an engine start-ignition switch, an idle stop release, an N2 power turbine governor "beep trim" control switch, a landing light on/off switch, and a landing light attitude control switch. The collective friction control is located mid collective on the pilot's outboard side. No throttle friction exists for either collective. The co-pilot's collective is removable.

For aircraft prior to S/N 5136, the copilot's collective switch box contains only two switches; a landing light attitude control switch and an N2 power turbine governor "beep trim" control switch. In addition, only the pilot's collective incorporates the idle stop release located between the forward end of the throttle and the collective switch box.

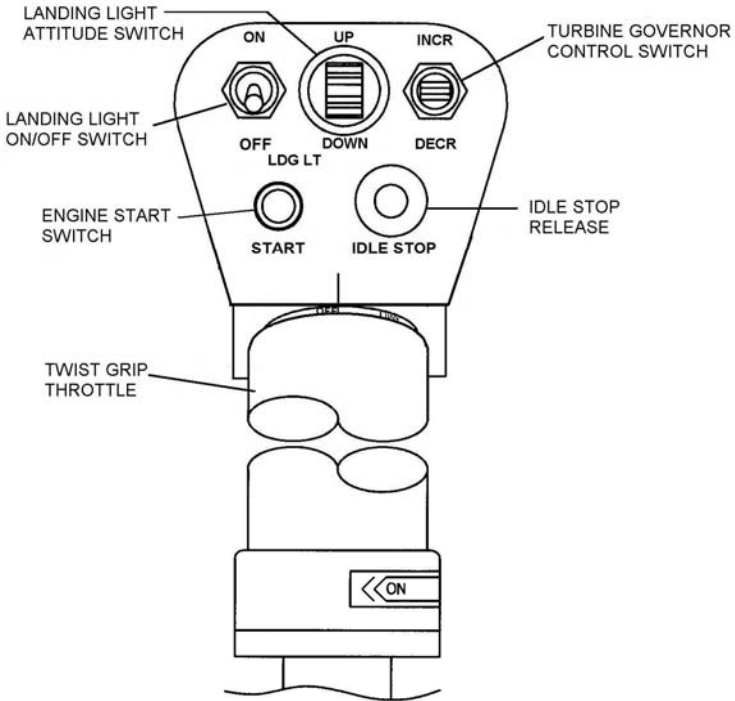

Pilot's Collective Control Box  
S/N 5136 and Subsequent

Figure 7-7. Collective Control Box

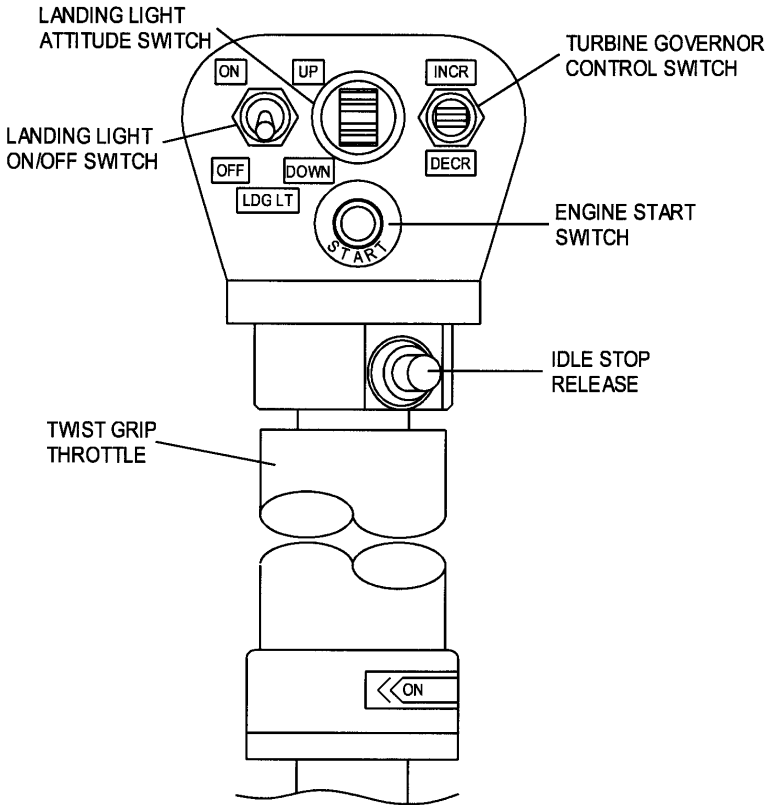

Pilot's Collective Control Box  
S/N 5135 and Earlier

Sheet 2 of 2

Figure 7-7. Collective Control Box

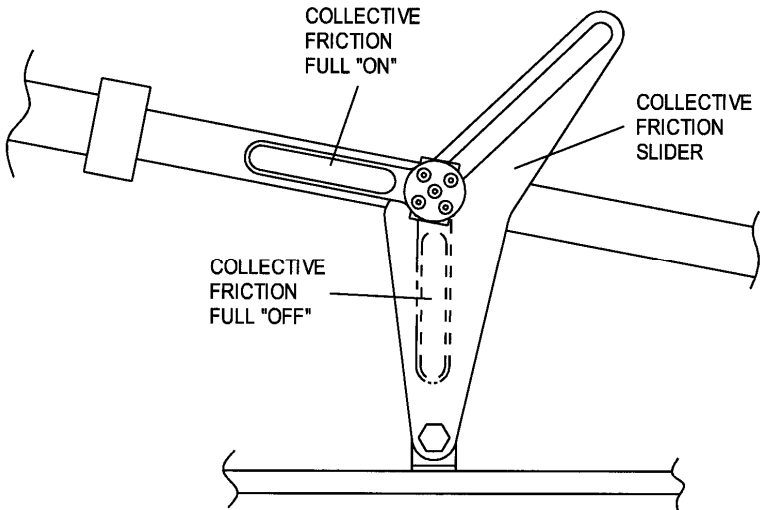

Figure 7-8. Collective Friction System



---

## CAUTION

---

**The collective friction mechanism is designed so that positive locking of the collective controls cannot be obtained at the maximum friction point. Safety of flight considerations require that the pilot be able to instantly overcome the established friction without any further pilot action to adjust it in the case of engine failure. Once friction has been applied the pilot should always check to ensure that it can be overcome by making a small collective movement to test it. If there is too much resistance, reset the friction lever to where it is satisfactory and make an entry in the maintenance logs to have maintenance personnel readjust the friction.**

### **7-34. Collective Friction**

1. The collective friction system consists of a slider that incorporates both the up and down collective pitch stops and a knurled knob and lever used to clamp two friction disks to the slider bar. When the lever attached to the knurled knob is pointing straight at the floor the friction is completely removed. Collective friction is fully applied when the lever is approximately aligned with the collective control. Total movement of the collective friction lever from full "on" to full "off" is approximately 100° (Figure 7-8). The control may be positioned on any intermediate position for any desired level of friction.

### **7-35. Cyclic Pitch Control System**

1. General Description. The cyclic pitch control system is a fully mechanical control system which is linked to the swashplate through a series of interconnected push-pull tubes, a torque tube, and bellcranks. Both longitudinal and lateral control systems are totally independent with no intermixing before the individual inputs reach the swashplate. Non-rotating control inputs are transmitted to the rotating controls via a universal joint type swashplate at

the base of the transmission. Inputs are mixed at the swashplate and transmitted through a set of three long push-pull tubes through the center of the mast to pitch change bellcranks at the top of the hub and then through pitch change links to the blade pitch horns located on the leading edge of each blade. Cyclic control position is maintained and rotor feedback forces are reduced to zero through a dual acting jack-screw trim actuator installed in each control axis and located on the backwall of the cabin. Vibration absorber beams are installed on the upper lateral and longitudinal bellcranks located in the engine compartment. These beams reduce the mechanical feedback vibration felt in the cyclic controls caused by the main rotor blades.

2. Cyclic Control. The aircraft is equipped with optional dual cyclic sticks, each located directly in front of the respective pilot and copilot seats. The right hand cyclic is removable at floor level. The two sticks are mechanically interconnected so that the movement of one stick moves the other stick simultaneously. The switches mounted on each cyclic grip assembly control the systems marked by each switch on the grip (Figure 7-9). The "coolie hat" four way toggle switch (momentary contact) at the top center of the grip is used to control the four way cyclic control trim system. The two detent (momentary contact) ICS/Radio trigger switch located on the forward face of the grip is used to transmit on ICS (optional equipment) or on the selected communications radio (optional equipment). Each of the push button switches can provide the pilot remote control of frequency selection on the communications or navigation radio or other functions depending on the optional equipment installed.

3. Cyclic Trim Control. Cyclic trim control consists of a cyclic trim switch located at the top of each cyclic grip, a pair of electrically operated trim actuator assemblies (lateral and longitudinal) that vary the amount of force produced by the spring capsules on the lateral longitudinal trim units.

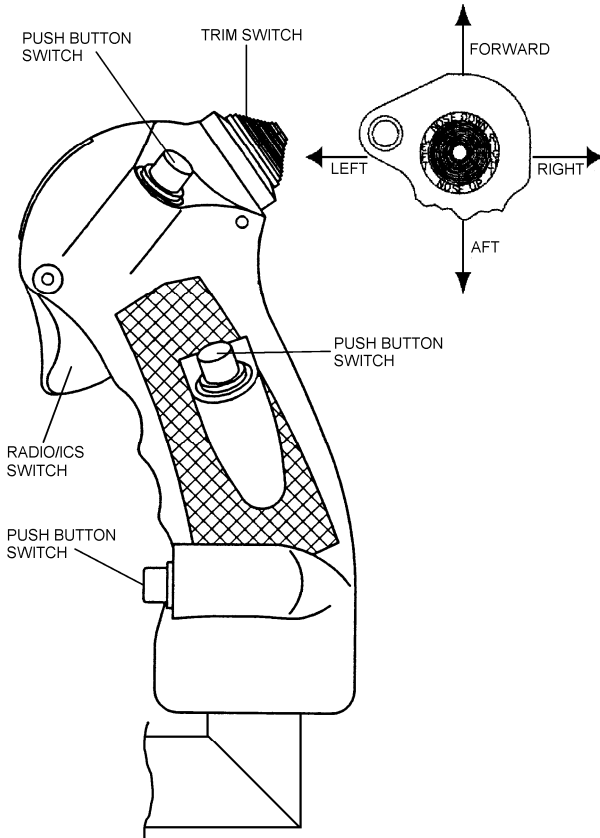

Figure 7-9. Cyclic Grip Switches

a. The cyclic trim switches each have five positions which are: normally OFF in the center, and momentary FORWARD, AFT, LEFT, and RIGHT. Both trim actuator assemblies include an electrically operated reversible motor and a spring capsule assembly. They are mounted on the pylon near the backwall. The spring capsules are connected to the cyclic control bellcranks. When a trim switch is moved off center to any one of the four trim directions, 28-volt, direct current power from the aircraft's electrical system, through the **TRIM** circuit breaker, energizes one of the trim motors to apply trim spring force in the desired direction. By momentarily moving the switch, very small trim increments may be obtained. Trim forces cannot be applied in two directions simultaneously; when both longitudinal and lateral trim corrections are desired, it is necessary to apply first one and then the other. The cyclic trim mechanism does not limit travel of the cyclic control; the pilot may override the trim forces at any time.

b. This type of trim system has been installed because there is no hydraulic system to block the normal feedback of rotor forces to the cyclic. Without any trim in either the longitudinal or lateral cyclic control system, as the helicopter accelerates into flight in any direction from a stabilized hover the pilot would have to counter the normal rotor reaction to increase in airspeed by holding rather significant cyclic forces in the direction of flight. The trim system allows the pilot to re-establish a new zero cyclic force trim point as the helicopter is maneuvered throughout its flight envelope thereby maintaining very low cyclic forces and thus workload. Because the cyclic control inputs are not mixed until they reach the swashplate, the pilot will experience the rotor aerodynamic force feedback as it occurs at the rotor. Therefore, as the helicopter accelerates into forward flight he will experience a requirement to trim first forward and then more predominantly to the right as airspeed builds and vice versa as the airspeed decreases. In addition, in stabilized forward flight, deviations from a trimmed condition at a given airspeed will be most immediately noticed by the pilot as a requirement for lateral re-trimming as the airspeed increases or decreases, followed by a requirement to re-trim in the longitudinal axis

as the lateral forces are zeroed. The ratio of the lateral force to longitudinal force feedback into the cyclic is on the order of three to one. Thus the pilot will almost always experience the highest trimming activity in the lateral axis as the helicopter is maneuvered. Since the rotor force feedback is significant, the trim unit forces to counter the rotor forces must, of necessity, be fairly high also. Therefore, if the pilot chooses not to re-trim during maneuvers or accelerations and decelerations of the helicopter, he will be forced to supply rather significant force at the cyclic.

c. A preferred method of flying this type of fully reversible control system is to lead the cyclic movement with trim. In this manner the trim motors do all of the work and the pilot must then only supply small force input to make the final adjustment to achieve the desired cyclic position as the helicopter is maneuvered.

### **7-36. Tail Rotor (Antitorque) Control System**

1. General. The tail rotor control system provides directional control of the aircraft by varying the pitch in the tail rotor blades. Depressing either of the antitorque pedals moves a system of bellcranks and control cables that travel through the tailcone to the tail rotor assembly.

2. Antitorque Pedals. The antitorque pedals are located on the floor directly in front of the pilot's and copilot's seats. The right-hand set of pedals can be removed at floor level. Pushing forward on the left pedal changes the aircraft heading toward the left, and pushing forward on the right pedal changes the aircraft heading toward the right. A full 8 inches/20 cm of pedal adjustment is available, to suit the individual pilot, by removing the quick release pins located at the top of the pedestal arms, repositioning the pedals and reinstalling the pins. There are two slots available for adjustment on the top of each pedestal arm, one horizontal and one angled. The pilot may select either corresponding pair to hold the pedals so that the pedal bar can be positioned under the desired area of the boot or shoe for ease of pedal movement.

### 7-37. Dual Control Removal

1. The right set of flight controls (optional dual controls) is removable for the single pilot plus cargo or passenger configuration.
  - a. Tail Rotor Pedals: Pull the pit pins at the base of the tail rotor pedal pedestals and slide the pedestals and pedals out of the sockets.
  - b. Cyclic Control: Remove the safety pin and unscrew the knurled knob at the base and pull the cyclic free. Unplug the wire bundle from the junction box on the right rear cabin wall. Cover the exposed plugs with the cap furnished with the box.
  - c. Collective Control: Pull the pit pin at the base, slide the collective forward out of its socket, unplug the wire bundle from the right rear wall cabin junction box. Install cyclic and tail rotor socket covers.
  - d. To re-install the dual controls, reverse the process.

## SECTION VI. POWER TRAIN

### 7-38. Power Train

1. The power train includes the main rotor transmission, upper pulley, drive belt, lower pulley, lower pulley drive shaft, overrunning clutch, power output drive shaft, short tail rotor drive shaft, long tail rotor drive shaft, and the tail rotor transmission. Figure 7-10 shows a simplified illustration of the power train.

### 7-39. Main Rotor Transmission

1. The main rotor transmission is a splash lubricated ring and pinion geared transmission that changes the direction of drive, reduces the rotational speed by a 7.154 to 1 gear ratio, and transmits all of the lifting and flight loads of the main rotor to the pylon. An oil level sight gage is located on the right rear of the transmission and can be viewed by looking between the blades of the upper pulley fan below the right rear of the upper plenum chamber. A bayonet type chip detector installed in the drain plug is incorporated. The main rotor transmission is equipped with an oil filtration/cooling system. This system consists of a heat exchanger, an electric pump, a pressure switch, a filter assembly, connecting oil lines, and the mounting brackets and hardware. The heat exchanger is located on the transmission forward of the upper pulley assembly. The electric pump is a 24 Vdc unit powered through the **XMSN PUMP** circuit breaker and located on the left side of the pinion area of the transmission. The pressure switch is installed between the heat exchanger and the inlet port of the pump. The pressure switch controls the **MAIN XMSN PRESS** segment light in the caution panel that indicates when the pump inlet pressure is less than 4.4-5.9 psi/30.2-40.7 kPa of vacuum. The filter assembly, located at the left aft area on the bottom of the transmission, incorporates a 10-12 micron spin-on oil filter. The filter assembly also incorporates the chip detector and a check valve that is used to prevent loss of oil in the transmission due to a break in the system between the filter housing outlet and the pump inlet. The oil filtration/cooling system does not provide pressure

lubrication for the main rotor transmission; failure of the pump does not adversely effect the lubrication of the main rotor transmission. Total oil capacity in the transmission is 6.5 pints/3.1 liters.

#### **7-40. Tail Rotor Transmission**

1. The tail rotor transmission is mounted at the aft end of the tailcone on the torque extension (stinger) tube. It supports and drives the tail rotor assembly and has a 1:1 gear ratio. The tail rotor transmission is splash lubricated and non-vented. A filler port and sight gage are located on the aft side of the transmission and it is equipped with a chip detector. The total oil capacity of the tail rotor transmission is 5 ounces/147 ml.

#### **7-41. Tail Rotor Drive Shaft**

1. The tail rotor drive shaft is a two section drive shaft connected to each other and the main and tail rotor transmissions by means of six bolt flex couplings comprised of multiple thin stainless steel plates bolted to the coupling drive flanges. These drive couplings permit the normal small angular misalignment caused by tail rotor thrust and aerodynamic loading on the tailcone. The short section of drive shaft directly aft of the upper pulley connects the main rotor transmission pinion shaft to the long tail rotor drive shaft and is easily removable to facilitate maintenance on the main drive system components. The long tail rotor drive shaft is a single piece steel tube supported by a series of grease lubricated hangar bearings and covered by a drive shaft cover.

#### **7-42. Upper Pulley**

1. The upper pulley is a grooved aluminum pulley keyed to the main rotor transmission drive pinion and designed with internal spokes that are made in the form of fan blades. The upper pulley provides rotational speed reduction from the engine power output shaft speed of 6196 RPM at 103% N<sub>2</sub> to tail rotor drive shaft speed of 2661 RPM by means of pulley diameter ratio relative to the lower pulley, transmits the engine power delivered by the



main drive belt to the main and tail rotor, and provides a motive force to draw cooling air over the main transmission and out of the upper engine compartment. The upper pulley is supported by a grease lubricated bearing assembly and truss located at the aft end of the pulley and the main rotor pinion shaft.

### **7-43. Lower Drive Pulley**

1. The lower drive pulley is a small diameter grooved aluminum pulley designed to receive the power from the engine by means of the drive shafting out of the overrunning clutch. The lower pulley rotates at engine power output shaft rotational speed of 6196 RPM at 103% N<sub>2</sub>. The lower pulley provides rotational speed reduction by means of pulley diameter ratio relative to the upper pulley, and transmits the engine power to the upper pulley by means of the main drive belt. The lower pulley is held in position at the bottom of the "H" strut by two oil lubricated bearing assemblies, one at either end of the pulley. The bearing assembly housings transmit the drive belt tension loads to the "H" strut so that the engine and lower pulley drive shafting only carry torque loads. The lower end of the "H" strut is free floating, i.e. not attached to the airframe, and is held in position by two adjustable rods extending horizontally from each of the lower pulley bearing housings to a vibration absorber on the right side of the pylon. These rods are used only for lateral positioning of the lower end of the "H" strut.

### **7-44. Drive Bearing Hot Caution Light**

1. Because the lower pulley rotates at engine power output shaft speed (over 6000 RPM), the condition and proper lubrication of the lower pulley bearings is critical for safe operation. Normal operating temperature of the lower pulley bearings is 80 to 100°C. If, however, the bearings are in an abnormal operating condition due to impending failure or total loss of lubrication then they will run excessively hot. For this reason, thermocouples are installed in the lower pulley bearing housings and the electrical signals from each thermocouple are monitored by a bearing temperature monitor. The threshold of the

monitor circuit has been set at 120°C, at which point a switch in the monitor circuit will close and activate the **DRIVE BRG HOT** caution light on the caution panel. Should the bearing temperature subsequently decrease, the switch in the monitor unit will open at 100°C and will extinguish the caution light.

---

**CAUTION**

---

**Any activation of this caution light should be taken seriously, the flight terminated immediately with power applied for the descent and landing, NOT in autorotation, and immediate corrective maintenance performed.**

### **7-45. Lower Pulley Drive System**

1. Figure 7-10 depicts a simplified drive system assembly. Engine power is transmitted to the drive system through the engine power output shaft to the overrunning clutch located on the front side of the engine accessory gearbox. The overrunning clutch then transmits the engine power through a splined shaft (power output shaft) that runs back through the center of the overrunning clutch and the engine power output shaft to the rear of the engine accessory gear case where it is coupled to the lower pulley drive shaft by means of a flex coupling. The lower pulley drive shaft then passes through the hollow center of the lower pulley and mates with a splined hub bolted to the aft end of the lower pulley via another flex coupling. The splining on the drive shafting isolates the engine from any fore and aft loading in the drive system and the flex couplings between the power output shaft and the lower pulley drive shaft allows for as much as 1.5° of pulley-engine angular misalignment.

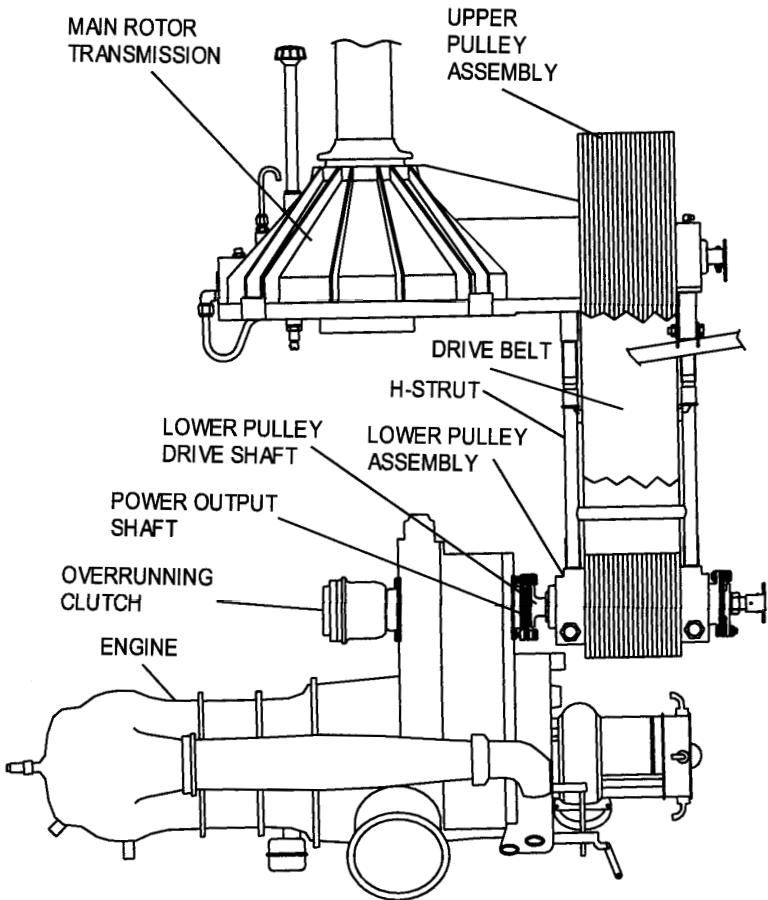

Figure 7-10. Power Train

## 7-46. Overrunning Clutch

1. The overrunning clutch is installed on the front side of the engine accessory gearbox. The engine power output drive shaft is a splined shaft inside the accessory gearbox. The outer housing of the overrunning clutch forms the driving portion of the clutch and is driven by a hollow splined shaft extension that slides into the engine power output shaft from the front side of the engine accessory gearbox. In the driving direction, the sprags engage and connect the outer housing to an inner drive housing which transmits the engine torque to a splined shaft (power output shaft) that passes through the center of the engine power output shaft to the rear of the engine accessory gearbox where it is coupled to the lower pulley drive shaft as described in paragraph 7-45. In the overrunning direction the power output shaft, being driven by the rotor system, will be rotating faster than the outer housing of the overrunning clutch and the sprags will disengage thus disconnecting the engine from the rotor drive system. The overrunning clutch is a sealed unit and contains its own lubrication separate from the engine.

2. Some aircraft are equipped with a vented clutch oil reservoir. The oil reservoir consists of a vented container with a sight glass and service port, and a top air/oil vent line and a bottom oil return line, each running to the bearing housing that supports the clutch. The reservoir is vented at the top, allowing oil to remain in the system while air is forced out and drawn in during engine operation.

## 7-47. Main Drive Belt

1. The main drive belt is a single, endless synthetic rubber Poly-V belt with a series of parallel V-ribs molded lengthwise around the inside circumference and a Kevlar® backing that makes it extremely strong and stable. The belt diameter, width, and number of grooves are all computed for stress in relation to the amount of horsepower required. The belt itself is made of a high

strength, shock resistant treated cord which provides dimensional stability and long flex life. This cord runs in a continuous fashion around the circumference of the belt and is imbedded in a fiber reinforced rubber compound for maximum cord support and adhesion. There is no splice in the belt. It is one continuous roll with an outside Kevlar® skin bonded to the belt itself for maximum strength. The belt is installed under a constant 2000 pounds/909 kg static tension and is capable of accepting well over 350 SHP/261 kW without slipping. The belt is installed over the upper and lower pulleys then tensioned by two jack screws on the H-strut.

#### 7-48. Indicators and Caution Lights

1. Main Transmission Oil Temperature Indicator. The **XMSN OIL TEMP** indicator is a microprocessor based indicator and displays the temperature of the transmission oil in degrees Celsius. The indicator's microprocessor performs a power-on self-test when power is connected to the indicator and also continuously monitors "sensor reasonableness" (Refer to para. 7-28.9). The microprocessor in the indicator will illuminate the LED RED when the maximum oil temperature limit is exceeded (Refer to para. 7-76.2.c). The indicator is powered from the aircraft 28-volt electrical system through the **XMSN** or **XMSN TEMP** circuit breaker.

2. Main Transmission Oil Hot Caution Light. The **MAIN XMSN HOT** caution light on the caution panel will illuminate when the main transmission oil reaches a temperature of 107°C and rising, and will extinguish when the oil temperature reaches 100°C decreasing. The circuit receives its signal from a set of contact closures within the main transmission oil temperature indicator and its electrical power from the aircraft 28-volt electrical system through the **CAUT PNL** circuit breaker.

3. Drive Bearing Hot Caution Light. This caution light is discussed in paragraph 7-44.

4. Main and Tail Rotor Transmission Chip Detector Caution Lights.

- a. General. Both the main and tail rotor transmissions have magnetic chip detectors installed. Whenever sufficient metal particles collect on the plugs to close the electrical circuit, the associated chip caution light will illuminate. Each caution light receives its signal from its associated chip detector and power from the aircraft 28-volt electrical system through the **CAUT PNL** circuit breaker.
- b. Programmable Continuity Sensors. Incorporated in each chip detector circuit is a Programmable Continuity Sensor (PCS). Any time electrical power is applied to the caution panel, or the caution panel test switch is placed in the test position for more than three seconds, the PCS will go through a 5 second continuity check to ensure that both circuits are complete. During that time, the **MAIN XMSN CHIP** and **TAIL CHIP** caution lights will remain illuminated then extinguish. If there is a break in continuity anywhere in the circuit, the associated caution light in the faulty circuit will not respond to the 5 second test.

## SECTION VII. MAIN AND TAIL ROTOR GROUPS

### 7-49. Main Rotor Systems

1. The main rotor assembly is a three bladed, high inertia, fully articulated rotor system.

2. Rotor Blades. The blades are of hollow construction consisting of an extruded leading edge spar, with a 7.25° twist, to which upper and lower aluminum skins are bonded. The root retention is composed of a bonded doubler assembly and a single retention pin connecting the blade root to the blade grip and a non-adjustable drag brace connecting the trailing edge of the blade to the grip. A cap is riveted into the tip of each blade in which there are provisions for spanwise and cordwise balance weights. Two tracking tabs are riveted to the trailing edge of each blade.

3. Rotor Hub. The rotor head assembly is composed of two opposing forged aluminum hub plates separated by an aluminum spacer. Steel spline adapters mounted on the hub plates mate the hub assembly to the main rotor shaft. Three steel universal blocks are mounted in roller bearings that permit lead-lag motions. Laminated phenolic pads are used to limit blade travel in both the lead-lag and flapping axes. A thrust nut on the bottom of each universal block transfers vertical blade forces to both hub plates through the universal block. The rotor blades are secured to each universal block on the hub through retention assembly consisting of a forged aluminum blade grip which is in turn secured to a steel spindle assembly through a tension-torsion strap assembly and supporting bearings. Centrifugal blade loads are carried by a tension-torsion strap assembly mounted between the blade grip and the spindle. The flapping bearings in the universal blocks are oil lubricated verses grease lubrication used for the lead-lag bearings in the universal blocks and the feathering bearings in the retention assemblies. Oil reservoirs for the flapping bearings are mounted on the top of the main rotor hub. Closed circuit hydraulic dampers are incorporated between each flapping pin and the rotor hub to limit the lead-lag velocity of the blades.

## 7-50. Main Rotor RPM Indicator

1. The rotor tachometer indicator (**ROTOR**) is part of the dual tachometer and is located on the instrument panel above the engine instrument cluster. The tachometer inner scale displays the rotor RPM. The inner scale pointer is marked with an "R". The main rotor tachometer indicator is powered by the aircraft 28-volt electrical system through the **N/R** or **NR TACH** circuit breaker and driven by a magnetic pickup mounted in the main rotor transmission. The pickup generates pulses that are a function of main rotor ring gear tooth passage. These pulses are then used to drive a servo motor within the indicator which in turn positions the main rotor RPM pointer to the indicated RPM of the main rotor. In the event of a main electrical bus failure, this instrument can be driven directly from the aircraft battery by moving the **N1-N2-NR-TOT** switch from **BUS** to **BATT**.

## 7-51. Rotor RPM Warning System

1. The aircraft is equipped with either a Low Rotor RPM Warning System or a Hi/Lo Rotor RPM Warning System. Some earlier aircraft may have been modified with the hi/lo rotor RPM warning system.

2. A low rotor RPM warning system is installed to provide a visual and audio indication of low rotor RPM. The low rotor RPM circuit is comprised of a magnetic sensor, a signal conditioning unit, a red warning light (**ROTOR RPM**), and a warning tone generator and horn. The magnetic sensor is located in the forward portion of the main rotor transmission housing. It is positioned to sense the passage of the ring gear teeth. The signal is sent to the signal conditioning unit located in back of the instrument panel. The unit receives the signal from the sensor and activates the light, located on the instrument panel, and the horn at 334 +/-1 rotor RPM. The light activates regardless of collective position. The audio system, however, is controlled by a microswitch located at the base of the pilot's collective. With a low rotor RPM condition, the audio signal will be silent as long as the collective is down and the microswitch is closed.



With the collective off of the down stop the low rotor RPM horn will activate generating a pulsing tone of 2900 Hz at 80-95 decibels. The system threshold can be adjusted using the potentiometer on the top of the signal conditioning unit. Power for the low rotor RPM warning system is provided by the aircraft 28-volt electrical system through the **LOW/RTR RPM** circuit breaker. There is no high rotor RPM warning.

3. The Hi/Lo Rotor RPM Warning System provides a visual and audio indication of low and high rotor RPMs. This system is essentially identical to the low rotor RPM warning system except it also indicates when the rotor RPM exceeds the upper limit. As with the low rotor RPM system, the horn is silenced when the collective is fully down. Thus, the horn will not sound if the RPM limit is exceeded during an autorotation with the collective fully down; the light will still illuminate.

## 7-52. Tail Rotor System

1. The tail rotor assembly is a two bladed, teetering, delta hinged rotor system. It is composed of two blade and grip assemblies mounted on a common spindle by a set of angular contact ball (thrust) bearings and a needle bearing assembly per blade and grip assembly. The center hub is teeter mounted in the spindle by two needle bearings. The center hub is splined to match the tail rotor transmission output shaft for positive mounting and driving. Pitch control of the tail rotor is accomplished through cables up to a sliding pivot yoke, then through pitch change links to the blade grips.

## SECTION VIII. HEATING AND VENTILATION

### 7-53. Bleed Air Heater and Defroster System

1. Cabin heating and windshield defrosting can be provided by an optional bleed air type system which consists of bleed air lines, two bleed air valves, two heater ejectors, two defroster flow diverters, and associated distribution system. The heater control valve is located under the cabin floor and the heater control, labeled **HEAT**, is used to operate the valve which modulates the bleed air flow to control the amount of heat supplied to the cabin. The heater control is located on the aft side of the center pedestal (Figure 7-5). The defroster control valve is also located under the cabin floor and its control, labeled **DEFR**, is located on the aft side of the center pedestal (Figure 7-5). When turned on, the heater ejectors use hot compressor bleed air to pull cabin air into a small mixing chamber and then expel the warm air into the cabin through eyeball socket type nozzles on both sides of the center pedestal near the pilot's and copilot's feet. The nozzles can be swiveled to direct warm air as the crew desires. The defroster system diverts some of the bleed air used for the heater system and routes it to a set of two ejectors and distributors mounted forward of the instrument console at the base of each front windshield. There is a small effect on aircraft performance when the heater and/or defroster system is used which is addressed in Chapter 4, Performance Data.

### 7-54. Windshield Demister

1. Windshield demisting can be provided by an optional demister fan assembly. The fan assembly is powered by the aircraft 28-volt electrical system through the **DEMIST FAN** fuse located in the fuse panel on the left side of the center pedestal. The fan is controlled by the **DEMISTER** switch located at the bottom of the center pedestal panel.

#### NOTE

**The aircraft will either be equipped with the Bleed Air Heater and Defroster System or the Windshield Demister.**

## 7-55. Ventilation System

1. Normal Flow Through Ventilation. The aircraft is equipped with pop out type vents in each cabin door to direct ram air into the cabin. There is also a pop out type vent on each side of the cabin in the lower portion of each rear opera window to provide additional flow across the back of the cabin area. Additionally, optional sliding vent windows are available for the cabin doors and the doors can be removed for flight if desired.

2. RAM Air Ventilation System. In addition to the normal flow through ventilation, the aircraft can also be equipped with an optional RAM air ventilation system. The control for this system, labeled **VENT**, is located on the aft side of the center pedestal (Figure 7-5). When activated, RAM air from outside the cockpit flows through a distribution system with nozzles mounted either side of the instrument panel.

## SECTION IX. ELECTRICAL POWER SUPPLY AND DISTRIBUTION SYSTEM

### 7-56. General

1. The 480B helicopter is equipped with a 28-volt direct current electrical system. Electrical power is supplied by a 28-volt, direct current, 150 ampere\*, engine driven starter-generator in conjunction with a 24-volt, lead acid battery. The aircraft may also be equipped with an optional NiCad battery. Control of the electrical system is provided by the **MAIN GEN** and **BATT** switches located at the top of the center pedestal panel. All circuits of the electrical system are protected by fuses, push-to-reset circuit breakers, or switch type circuit breakers. All circuits in the electrical system are single wire with common ground return. The negative terminals of the starter-generator and the battery are grounded to the helicopter pylon. The aircraft is also equipped with a non-resettable current limiter that protects the main bus in case of a direct short to ground. On aircraft S/N 5134 and subsequent, power is distributed from the main bus through a group of secondary buses; each one is also protected by a non-resettable current limiter. In the event of a complete electrical system failure, emergency electrical power, controlled by the **N1-N2-NR-TOT** switch, can be supplied to the gas producer tachometer (N<sub>1</sub>), dual tachometer (N<sub>2</sub>/N<sub>R</sub>), and TOT indicator.

\* On aircraft prior to S/N 5134, the electrical system is limited to 110 amperes. On aircraft S/N 5134 and subsequent, the electrical system is limited to 150 amperes. Power output is monitored via the Volt-Ammeter Indicator (Refer to Figure 1-1 and para. 7-61.).

### NOTE

**Early 480B's are equipped with a gas producer tachometer which does not require aircraft electrical power for operation. The emergency electrical power switch in these aircraft is labeled N2-NR-TOT.**

## 7-57. Battery

1. A single lead acid battery is used on the aircraft. An optional NiCad battery may be used in lieu of the lead acid battery. All batteries have identical 2 pin MS-3509 electrical receptacle connectors. Additionally, for all NiCad installations, a battery temperature monitoring and warning system is installed. At or above 145°F/63°C, the system will trigger the yellow **BATT TEMP** caution light in the caution panel to alert the pilot to the requirement for corrective action to prevent a thermal runaway. When the battery reaches 160°F/71°C, the monitor system will illuminate the red **BATT HOT** warning light in the caution panel to warn the pilot that a thermal runaway is imminent if positive corrective action by removing the battery from the charging circuit is not accomplished immediately. The battery is normally located on a platform aft of the right cabin backwall in the engine area. The battery may also be installed in the baggage box as required due to center of gravity limitations. The engine area and baggage box locations are both equipped with electrical, ventilation, and temperature monitoring connections for the battery. When the standard lead acid battery is installed, the BATT HOT and BATT TEMP segments in the caution panel are replaced with SPARE segments.

## 7-58. External Power Receptacle

1. During ground operations, external power may be connected to the electrical system through the external power receptacle located on the right side of the aircraft (near the battery) behind the right side engine access panel (Figure 7-11). The external power receptacle consists of a female connector that has two large pins and one small pin. The small pin closes the external power relay and connects the ground unit to the main aircraft electrical bus when external power is supplied. The **MAIN GEN** switch shall be in the **OFF** position when external power is connected. The battery will be charged anytime that external power is supplied to the aircraft, regardless of the battery switch position. See paragraph 8-11 for the

proper rating for an external power cart and the proper procedures for applying external power.

## 7-59. Generator

1. The 150 ampere capacity starter-generator is mounted on the engine power and accessory gearbox and supplies 28-volt direct-current power for operation of the aircraft electrical equipment and for battery charging. On aircraft prior to S/N 5134, the maximum allowed output is 110 amperes. On aircraft S/N 5134 and subsequent, the maximum allowed output is 150 amperes.

2. Generator. Generator operation is controlled by the **MAIN GEN** switch. At flight idle RPM and above, the voltage regulator portion of the generator control unit (GCU) automatically maintains the correct generator output by varying the generator field current. The generator field circuit is protected by the **MAIN GEN** circuit breaker located on the center pedestal panel.

3. Generator Control Unit. The generator control unit (GCU) provides control and protection for the generator. The main functions of the GCU are:

- a. Voltage regulation
- b. Overvoltage protection
- c. Reverse current protection
- d. Over current protection
- e. Generator relay control

4. When an overvoltage condition occurs, an overvoltage relay is energized by the GCU. The overvoltage relay opens the switch circuit of the reverse current relay to remove generator output from the bus. The reverse current relay prevents the battery from discharging through the generator when the generator output voltage falls below battery voltage. The aircraft electrical systems operate from the battery when the generator is OFF or off line and the battery switch is ON.

## 7-60. Generator Caution Light

1. Anytime that the DC generator output voltage is less than the battery voltage or the generator is OFF or otherwise disconnected from the aircraft main bus, the generator caution light, marked **DC GEN** on the caution panel, will illuminate.

## 7-61. Controls and Indicators

1. Volt-Ammeter. The dual indicating volt-ammeter (**DC**), located on the instrument panel, is a microprocessor based indicator and indicates the main bus voltage (**VOLT**) and the current load (**AMP**) being used. The indicator's microprocessor performs a power-on self-test when power is connected to the indicator and also continuously monitors "sensor reasonableness" (Refer to para. 7-28.9). The microprocessor in the indicator will illuminate the LED RED when the maximum operating limits are exceeded (Refer to para. 7-76.2.c). The indicator is powered by the aircraft 28-volt electrical system through the **VOLT/AMP** circuit breaker.

2. Battery Switch. The **BATT** switch is located at the top of the center pedestal panel. Battery electrical power is supplied to the helicopter's electrical system when the switch is in the **ON** position. When the switch is in the **ON** position, it closes the circuit to the battery relay coil and battery power is then connected to the main electrical bus. When the switch is placed in the **OFF** position, it opens the circuit to the battery relay coil and battery power is disconnected from the main electrical bus.

3. Generator Switch. The generator switch, labeled **MAIN GEN**, is located at the top of the center pedestal panel to the left of the battery switch. In the **ON** position the generator field is energized through the generator control unit and 28-volt generator power is supplied through the generator relay to the main electrical system bus. In the **OFF** position, the generator is disconnected from the main electrical bus.

**NOTE**

**On S/N's 5039-5076 and 5078-5084, the generator switch will be automatically tripped OFF if the engine starter button is pushed. It must be placed ON after the engine start is complete. On S/N's 5077, 5085 and subs., the generator switch must manually be cycled to RESET then ON if the starter button is pushed with the generator switch ON.**

4. N1-N2-NR-TOT Switch. The **N1-N2-NR-TOT** switch (Figure 7-10.1), located at the top right side of the instrument panel, controls the emergency electrical power circuits that provide power to the gas producer (N<sub>1</sub>) tachometer, Dual (N<sub>2</sub>/N<sub>R</sub>) tachometer, and the TOT indicator in case of a complete electrical system failure. Emergency power is supplied to the indicators by moving the switch from the **BUS** position to the **BATT** position. The emergency electrical power circuits are protected by the N1, N2, NR, and TOT circuit breakers located on the right side of the back wall in the engine compartment (Figure 7-11). A yellow LED, located next to the switch, illuminates when the switch is in the **BATT** position.

**NOTE**

**Early 480B's are equipped with a gas producer tachometer which does not require aircraft electrical power for operation. The emergency electrical power switch in these aircraft is labeled N2-NR-TOT.**

5. Avionics Master Switch. The **AVI MSTR** switch (Figure 7-4), located at the top of the center pedestal panel, controls and provides electrical power to the avionics bus. Equipment such as GPS/Nav/Com, transponder, CDI, HSI, or EHSI, or other avionic units are typically connected to the avionics bus. Switching the **AVI MSTR** to the OFF position disconnects electrical power to the avionics bus.



6. Circuit breakers and circuit breaker switches. The primary circuit breakers and circuit breaker switches for the aircraft are located either on the center pedestal panel or the instrument panel. Each individual circuit breaker/switch is labeled for the particular electrical circuit protected. In the event a circuit becomes overloaded, the circuit breaker protecting the circuit will pop out or the circuit breaker switch will release to the **OFF** position. The circuit may be reactivated by pushing the circuit breaker button back in or by cycling the circuit breaker switch thereby resetting the circuit breaker. Circuits for devices using direct power feed from the battery are protected by circuit breakers located directly beneath the external power receptacle on the right side of the backwall in the engine area.

7. Fuses. Nonessential equipment electrical circuits not protected by circuit breakers are fuse protected. The fuses are located on the left side of the center pedestal (Figure 7-12). For aircraft S/N 5134 and subsequent, the fuse panel is an option.

8. Current Limiters. The current limiter, located on the right side of the backwall in the engine compartment, is a non-resettable fuse that protects the main electrical bus in case of a direct short to ground. Optional current limiters are installed as needed for additional electrical circuits.

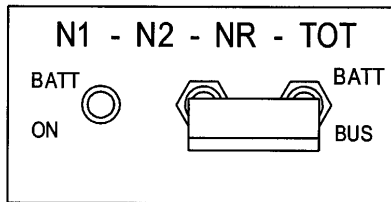

Current Configuration

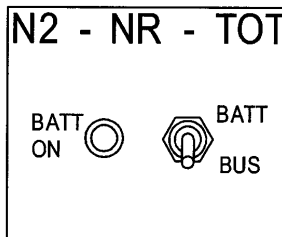

Early 480B Configuration

Figure 7-10.1. N1-N2-NR-TOT Switch

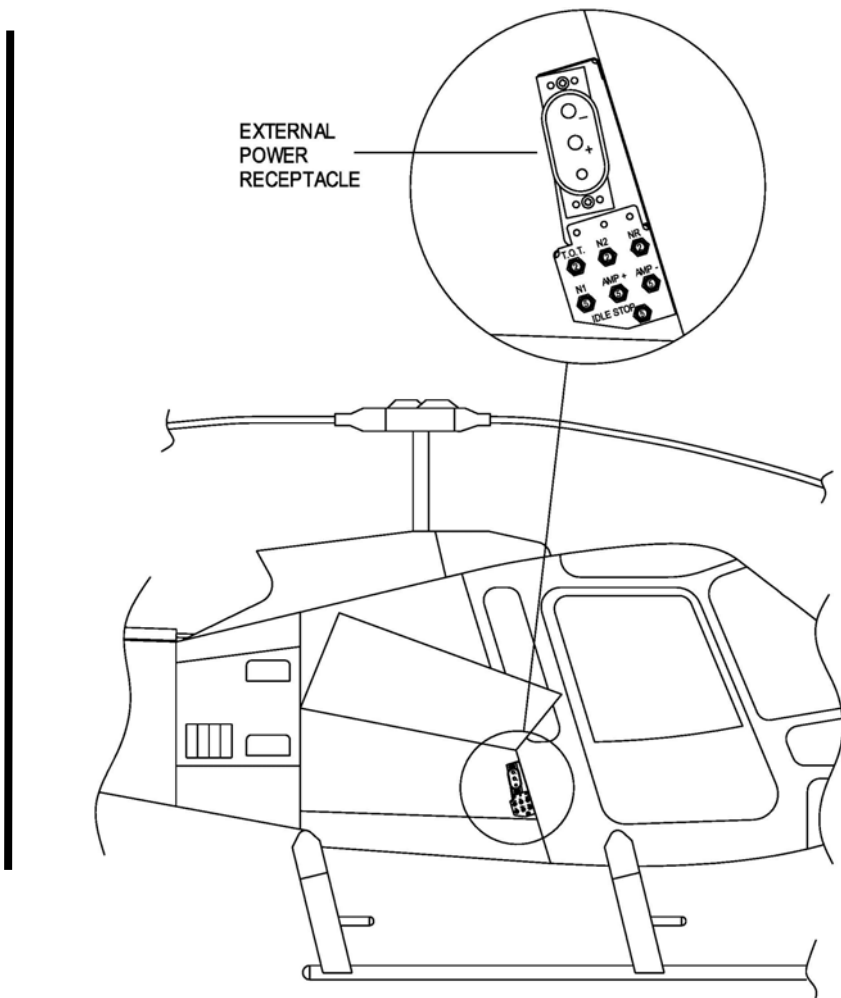

Figure 7-11. External Power Receptacle

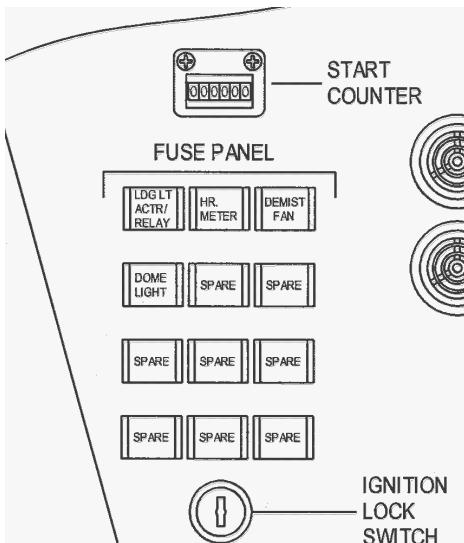

Figure 7-12. Fuse Panel – 110 Amp System

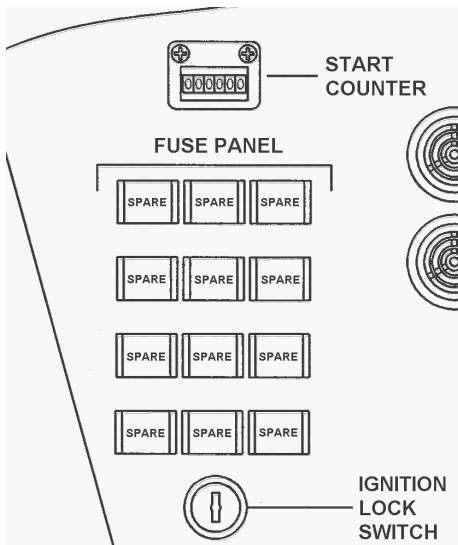

Figure 7-12.1. Fuse Panel Option – 150 Amp System

## SECTION X. LIGHTING

### 7-62. Position Lights

1. The position lights consist of four lights and are a part of the navigation/anticollision light clusters located on each tip of the horizontal stabilizer (right side green, left side red, and a white light facing aft in each cluster). Power for the position lights is provided by the aircraft 28-volt electrical system through the **NAV LTS** circuit breaker switch.

### 7-63. Anticollision Lights

1. The aircraft may be equipped with either flashing strobe-type anti-collision lights located on the tips of each horizontal stabilizer or LED beacon anti-collision lights installed above the cabin behind the main rotor mast and under the helicopter on the center belly panel. Some aircraft may have both types installed.

2. Power and control for the operation of the strobe lights is provided by the aircraft 28-volt electrical system through the **STRB LTS** circuit breaker switch. Power and control for the operation of the LED lights is provided by the aircraft 28-volt electrical system through the **BCN LTS** circuit breaker switch.

### 7-64. Landing Light

1. A moveable landing light is located in the lower nose section of the helicopter. Power for both the landing light and the control motor to extend and retract the landing light is provided by the aircraft 28-volt electrical system. The landing light may be activated by the switch on either the pilot's or copilot's collective control electrical switch box labeled **LDG LT**. The landing light control switch is a momentary switch spring loaded to the center-off position. When the switch is pressed forward to the **UP** position, the landing light extends (the light beam moves upward) as long as the switch is held in this position. When the switch is pulled backward to the down **DOWN** position, the landing light retracts (the light beam moves downward)

as long as the switch is held in this position. The landing light may be positioned anywhere within a 45° arc of travel in this manner. Releasing the switch to the center-off position removes power from the motor and stops the movement of the light. The landing light positioning motor is protected by the **LDG LT ACTR/RLY** circuit breaker. On aircraft prior to S/N 5134, the motor is protected by the **LDG LT ACTR/RLY** fuse. The actual light circuit is protected by the **LDG LT** circuit breaker.

### 7-65. Instrument Lights

1. The instrument lights are separated into three groupings; panel instruments, engine instruments, and radio instrument. Each grouping is controlled by its own associated solid state dimmer. Power to the dimmers, located at the bottom of the center pedestal panel, is provided by the **PNL LTS** circuit breaker switch located at the top of the center pedestal panel. Clockwise rotation of the dimmer control knobs increases the lighting brilliance. Counterclockwise rotation of the control knobs dims the selected circuit.

### 7-66. Cabin Dome Light

1. A cabin dome light is provided to illuminate the cabin with white light at night. The light is located on the forward center of the cabin roof. The light is controlled by the push button ON/OFF switch located on the light assembly. Power for the cabin dome light is provided from the aircraft 28-volt electrical system. Circuit protection for the light is provided by a circuit breaker labeled **DOMELT**. On aircraft prior to S/N 5134, circuit protection is provided by a fuse labeled **DOMELIGHT** located in the fuse panel on the left side of the center pedestal.

## 7-67. Map/Utility Light

1. An optional hand held map/utility light may be installed in the aircraft. The light is stowed for flight in the bayonet type holder and is within easy reach of the crew in flight. The map/utility light has a red filter that may be positioned over the normal white light, and a rheostat at the back of the light unit to control the intensity of the light. The light is also equipped with a momentary push button type rheostat override switch located on top of the rheostat that will activate the light to full bright as long as the switch is depressed. Power for the map/utility light is provided from the aircraft 28-volt electrical system. Circuit protection for the map light is provided by the **MAP LT** circuit breaker. On aircraft prior to S/N 5136, circuit protection is provided by a fuse labeled **MAP LT** located in the fuse panel on the left side of the center pedestal.

## SECTION XI. FLIGHT INSTRUMENTS

### 7-68. Airspeed Indicator

1. The aircraft is equipped with a 0-150 knot airspeed indicator calibrated in knots and miles per hour. The airspeed indicator indicates the airspeed of the helicopter during forward flight by measuring the difference between impact air pressure from the pitot tube and the static air pressure from the static ports mounted just forward of each main cabin entrance door. The standard pitot tube location is below the nose of the aircraft between the chin windows. An optional heated pitot tube can be installed on the nose of the aircraft. A chart correcting the cockpit indicated airspeed to calibrated airspeed is presented in Chapter 4, Performance Data, of this manual.

#### NOTE

**Airspeed indications at airspeeds below 20 knots are unreliable.**

### 7-69. Optional Pitot Heater

1. The aircraft may be equipped with an optional electrically heated pitot tube to prevent ice from forming in or on the pitot tube. Electric power for the pitot heater is supplied from the 28-volt aircraft electrical system through **PITOT HEAT** circuit breaker switch located at the top of the center pedestal panel.

### 7-70. Altimeter and Encoder

1. The aircraft is equipped with a non-altitude encoding pressure altimeter. The altimeter provides a direct reading of height above mean sea level when properly adjusted for the local altimeter setting. The aircraft can be equipped with an optional blind encoder for use with the transponder. The encoder is a sealed unit that is calibrated to provide the transponder coded pressure altitude information based on a standard altimeter setting of 29.92 inches of mercury. The transponder then transmits that altitude information to the ATC radar when transponder mode C is selected by the pilot.



### 7-71. Attitude Indicator

1. The aircraft can be equipped with an optional, electrically powered attitude indicator. The unit is equipped with a fixed pointer, a moving card type display, and a pilot adjustable aircraft reference symbol. The indicator is capable of 360° roll displacement and approximately ±85° pitch displacement. Pitch attitude graduations are typically marked every 5° to the first ±20°. An external caging knob provides simultaneous erection of the pitch and roll axes. The unit is also equipped with a slip indicator attached to the display bezel.

#### NOTE

**This attitude indicator must be erected manually each time electrical power is applied to the aircraft. To prevent unnecessary stress on the erection mechanism it is recommended that the "Pull For Quick Erect" or "Pull To Cage" knob be pulled and held by the pilot prior to applying battery or external power to the aircraft.**

### 7-72. Instantaneous Vertical Velocity Indicators

1. The optional vertical speed indicator displays the rate of helicopter ascent or descent in feet per minute. The indicator is capable of indicating up to 6000 feet per minute vertical velocity either direction and is actuated by the rate of atmospheric pressure change.

### 7-73. Turn and Slip Indicator

1. The optional turn and slip indicator displays the helicopter slip condition, direction of turn, and rate of turn. The ball displays the slip condition. The pointer displays the direction and rate of turn. The indicator receives power from the 28-volt aircraft electrical system and is protected by the **T&SL** circuit breaker.

## 7-74. Outside Air Temperature Indicator (OAT)

1. (S/N 5239 and prior) The OAT indicator is located at the top center area of the cabin to the left of the front windscreen center post. The indicator displays the OAT in both degrees Fahrenheit and Celsius.

2. (S/N 5240 and subsequent) The standard OAT indication is displayed on the upper half of the digital clock. Press the top red button once to sequence the display selection from Volts (power-up default) to OAT in Fahrenheit, again to OAT in Celsius, and again to repeat back to Volts.

## 7-75. Magnetic Compass

1. The magnetic compass is mounted on the center post of the windshield. A compass correction card is located next to the compass.

### 7-75.1. Alternate Static Air Source

1. The aircraft can be equipped with an optional alternate static air source which allows the pilot to use the interior of the cabin as a static reference. Due to inherent inaccuracies, this system should only be used when necessary, for example if icing conditions are encountered and cannot be avoided.

2. Refer to Section 4, paragraph 4-11.1. for applicable airspeed and altimeter corrections when the alternate static air source is used.

3. To use the alternate static air source, move the **STATIC AIR** switch (located in the instrument panel) from **STD** to **ALT**. To return to the standard static air source, move the **STATIC AIR** switch from **ALT** to **STD**.

## SECTION XII. CAUTION AND WARNING SYSTEMS

### 7-76. Caution and Warning Systems

1. The caution system consists of a caution panel located in the instrument panel, and a remote **MASTER CAUTION** annunciator/switch, which is also a push-to-reset switch, located on the instrument panel. Additionally, microprocessor based indicators for the engine, main rotor transmission, fuel quantity, and electrical systems are equipped with an LED that illuminates RED when an operating limitation is approached or exceeded. The warning system consists of three individual red warning lights located at the top of the instrument panel. The purpose of the caution and warning system is to provide visual indication, suitable for day and night operation, that a fault condition has occurred.

#### NOTE

**Early 480B's are not equipped with the microprocessor based indicators.**

2. Caution System. The caution panel, depicted in Figure 7-13 and described in Table 7-1 is composed of 20 individually worded segments which, when illuminated, identify specific fault conditions. The worded segments are only visible when illuminated. Each segment has four LEDs wired as two pairs of independent circuits so that the failure of a single LED will produce only a dimming effect. When a fault occurs, the associated worded segment on the caution panel illuminates flashing at a 2 Hz rate, and the **MASTER CAUTION** annunciator/switch (light) also illuminates flashing at the same rate. When the pilot acknowledges the fault by pressing in on the **MASTER CAUTION** light, the **MASTER CAUTION** light will extinguish and the fault on the caution panel will reset to a steady ON condition. Each fault condition, as it occurs, is indicated by the same sequence of events as described above. In each case, only the new fault will flash until acknowledged. Only faults annunciated by the caution panel will activate the **MASTER CAUTION** light (**ROTOR RPM**, **ENGINE OUT**, and **FIRE** will not activate

the **MASTER CAUTION** light). In addition, because the **ENG ANTI-ICE**, **LDG LIGHT ON**, **LDG LIGHT PULSE**, and **CARGO HOOK ARMED** lights indicate a normal system status rather than a fault, they will not activate the **MASTER CAUTION** light, and they do not flash.

3. For aircraft S/N 5135 and earlier, the caution panel is composed of 15 individual worded segments consisting of two lamps. Failure of a single lamp will produce only a dimming effect. In addition, the **ENG ANTI-ICE** segment light is the only normal system status segment available.

a. Caution Panel Test. Pressing the **CAUT PNL** switch to the **TST** position will illuminate all of the segments of the caution panel and the **MASTER CAUTION** light, plus the **FIRE**, **ROTOR RPM**, and **ENGINE OUT** warning lights testing all of the light bulbs and the three chip detector circuits. Release of the **TST** switch to the **BRT** position resets the caution panel to its previous state before the **TST** switch was pressed. Fault conditions will not be altered as a result of the test. Holding this switch in the test position for 3 seconds or longer will activate the chip detector continuity test circuits.

b. Caution Panel Dimming. For night flight, the **CAUT PNL** switch can be set to the **DIM** position to select a preset dim condition for the caution panel. In this condition, each fault as it occurs will trigger its associated caution segment to a full bright and flashing condition along with the **MASTER CAUTION** light. Pressing the **MASTER CAUTION** light will reset the caution panel fault segment to steady and dim. Subsequent faults will be annunciated in the same manner with only the new fault triggered to bright-flashing until it is acknowledged, not the previously acknowledged faults.

c. Indicator Caution Activation. The microprocessor based indicators will illuminate the LED, located on the instrument face, red when an operating limitation is approached or exceeded. The LED remains illuminated until the indication is within the operating limitations. The instrument LED indications are intended as an alert

to call the pilot's attention to the indicator. The indicator reading is the correct indication of an exceedence. Depending on the exceeded limitation, a corresponding activation of the **MASTER CAUTION** light and a segment in the caution panel may occur, at which point the pilot may acknowledge the fault by pressing the **MASTER CAUTION** light. Refer to Table 7-3 for a description of the systems and operating limitations included with the microprocessor based indicators.

3. Warning System. The warning system consists of three independent red warning lights at the top of the instrument panel as shown in Figure 7-13 and described in Table 7-2, and one red **BATT HOT** warning light located in the caution panel and described in paragraph 7-57. Because of its location in the caution panel, the **BATT HOT** light operates in exactly the same manner as the caution lights described previously. When the optional NiCad battery is installed, the SPARE segment in the caution panel is replaced with a **BATT HOT** segment. The remainder of this paragraph applies only to the **FIRE**, **ROTOR RPM**, and **ENGINE OUT** warning lights. When each light is activated it comes on steady and full bright with no dimming capability. The warning lights are for conditions that require immediate pilot action.

2. Fire Warning System. This system is described in paragraph 7-13.

3. Engine Out Warning System. This system is described in paragraph 7-28.

4. Rotor RPM Warning. This warning system is described in paragraph 7-51.

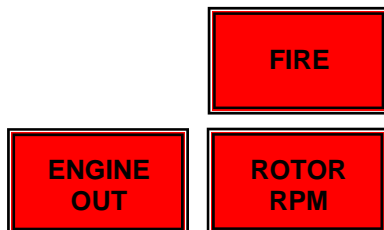
**WARNING LIGHTS****CAUTION PANEL**

Aircraft S/N 5136 and Subsequent

<b>ENG CHIP</b>	<b>MAIN XMSN CHIP</b>	<b>TAIL CHIP</b>	<b>FUEL FILTER</b>
<b>ENG OIL TEMP</b>	<b>MAIN XMSN HOT</b>	<b>DRIVE BEARING HOT</b>	<b>A/F FUEL FILTER</b>
<b>ENG OIL PRESS</b>	<b>MAIN XMSN PRESS</b>	<b>BATT TEMP</b>	<b>FUEL LOW</b>
<b>ENG INLET AIR</b>	<b>DC GEN</b>	<b>BATT HOT</b>	<b>SPARE</b>
<b>ENG ANTI-ICE</b>	<b>LDG LIGHT ON</b>	<b>LDG LIGHT PULSE</b>	<b>CARGO HOOK ARMED</b>

Sheet 1 of 2

Figure 7-13. Warning and Caution Lights

### CAUTION PANEL

Aircraft S/N 5135 and Earlier

ENG CHIP	MAIN XMSN CHIP	TAIL CHIP
ENG OIL TEMP	MAIN XMSN HOT	DRIVE BRG HOT
ENG OIL PRESS	MAIN XMNS PRESS	SPARE
ENG INLET AIR	SPARE	DC GEN
FUEL FILTER	FUEL LOW	ENG ANTI-ICE

### MASTER CAUTION ANNUNCIATOR/SWITCH



Sheet 2 of 2

Figure 7-13. Warning and Caution Lights

**Table 7-1. Caution Panel Segments**

<b>SEGMENT</b>	<b>COLOR</b>	<b>DESCRIPTION OF FAULT</b>
<b>ENG CHIP</b>	<b>AMBER</b>	Engine scavenge oil has ferrous metal fragments
<b>MAIN XMSN CHIP</b>	<b>AMBER</b>	Main transmission chip detector has detected ferrous metal fragments
<b>TAIL CHIP</b>	<b>AMBER</b>	Tail rotor transmission chip detector has detected ferrous metal fragments
<b>FUEL FILTER</b>	<b>AMBER</b>	Pressure drop in the fuel filter exceeds 1.3 psi and filter bypass is impending
<b>ENG OIL TEMP</b>	<b>AMBER</b>	Engine oil temperature is above 107°C
<b>MAIN XMSN HOT</b>	<b>AMBER</b>	Main transmission oil temperature is above 107°C
<b>DRIVE BRG HOT</b>	<b>AMBER</b>	Either the forward or aft lower pulley bearings are above 120°C
<b>A/F FILTER*</b>	<b>AMBER</b>	Airframe fuel filter bypass is impending
<b>ENG OIL PRESS</b>	<b>AMBER</b>	Engine N <sub>1</sub> RPM is above 78.5% and engine oil pressure is below 90 psi, or anytime engine oil pressure is below 50 psi
<b>MAIN XMSN PRESS</b>	<b>AMBER</b>	Pump inlet pressure is less than 4.4-5.9 psi/30.2-40.7 kPa of vacuum
<b>BATT TEMP**</b>	<b>AMBER</b>	Battery temperature is at or above 63°C
<b>FUEL LOW</b>	<b>AMBER</b>	Fewer than 5 gallons/19 liters of fuel remaining
<b>ENG AIR INLET</b>	<b>AMBER</b>	Engine inlet particle separator partially blocked
<b>DC GEN</b>	<b>AMBER</b>	DC Generator system failure
<b>BATT HOT**</b>	<b>RED</b>	Battery temperature is at or above 71°C
<b>SPARE</b>	<b>AMBER</b>	Spare segment
<b>ENG ANTI-ICE</b>	<b>GREEN</b>	Engine anti-ice is activated
<b>LDG LIGHT ON</b>	<b>GREEN</b>	Landing light is activated
<b>LDG LIGHT PULSE*</b>	<b>GREEN</b>	Pulse landing light is activated
<b>CARGO HOOK ARMED*</b>	<b>GREEN</b>	Cargo hook electric release is armed

\* Segment is only installed if the optional equipment is installed.

\*\* Segment is only installed if the optional NiCad battery is installed.



**Table 7-2. Warning Lights**

LIGHTS	COLOR	DESCRIPTION OR FAULT
<b>ROTOR RPM</b>	<b>RED</b>	Low Rotor RPM Warning System: Main rotor RPM below 334 RPM. Hi/Lo Rotor RPM Warning System: Main rotor RPM below 334 RPM or above 385 RPM. (See paragraph 7-51).
<b>ENGINE OUT</b>	<b>RED</b>	Engine N <sub>1</sub> below 58%
<b>FIRE</b>	<b>RED</b>	The fire detection system has detected either a fire or an extreme overheat condition in either the upper or lower engine compartment.

**Table 7-3. Indicator Caution Activation**

**INDICATOR      CORRESPONDING      DESCRIPTION OF FAULT  
CAUTION SEGMENT**

TORQUE	NO	Exceed 72 PSI
N <sub>1</sub> TACH	NO	Exceeds 105%
TOT	NO	Exceeds 10 seconds between 810-927°C during start Exceeds 810°C during normal operations
DC VOLT	NO	Exceeds 32 Vdc
DC AMP	NO	Prior to S/N 5134: Exceeds 110 Amps S/N 5134 and subsequent: Exceeds 150 Amps
ENG OIL TEMP	YES	Exceeds 107°C
ENG OIL PRESS	YES*	Less than 50 PSI Exceeds 130 PSI
XMSN OIL TEMP	YES	Exceeds 107°C
FUEL QTY	YES**	Less than 35 LBS

- \* The caution panel monitors both N<sub>1</sub> speed and engine oil pressure for controlling the **ENG OIL PRESS** segment. The indicator caution activation only uses engine oil pressure.

- \*\* The indicator caution is independent of the **FUEL LOW** segment in the caution panel.

## SECTION XIII. MISCELLANEOUS SYSTEMS

### 7-77. Ignition Lock Switch

1. The ignition lock switch, located on the left side of the center pedestal (Figure 7-12), must be in the **ON** (horizontal) position for engine start-up. The switch is wired in the engine start circuit between the start relay circuit breaker and the starter button. The switch must be in the **OFF** (vertical) position to remove the key.

### 7-78. Hour Meter

1. The hour meter, located on the left side of the center pedestal (Figure 7-12), records engine operating time. The hour meter is powered by the aircraft 28-volt electrical system through the **HR METER** circuit breaker and is controlled by an oil pressure switch mounted in parallel with the engine oil pressure transducer. On aircraft prior to S/N 5134, the hour meter circuit is protected by the **HR METER** fuse. Starting with aircraft S/N 5048, a collective microswitch is incorporated into the hour meter system. The hour meter in aircraft S/N 5048 and subsequent records flight time.

### 7-79. Start Counter

1. The start counter, located on the left side of the center pedestal, records when electrical power is supplied to the engine ignition exciter. Start count information is required for tracking life limited components of the engine. The start counter is powered by the aircraft 28-volt electrical system through the **IGN EXCITE** circuit breaker.

#### NOTE

**Prior to serial number 5048, the start counter is located next to the ignition exciter on the engine.**

## 7-80. Power Sockets

1. The aircraft may be equipped with optional power sockets. The power sockets provide a source of 28Vdc and/or 14Vdc power for powering portable/removable devices from the aircraft electrical system. The power sockets, located on the top or sides of the center pedestal assembly, are protected by either fuses or circuit breakers (refer to the supplemental schematic diagrams provided with the aircraft).

2. The power sockets are placarded with the voltage type and maximum current load.

## 7-81. Headset Jacks

1. The aircraft is equipped with headset jacks for each seat position. Insert the headset plug into the jack that corresponds with the seat in the aircraft.

### NOTE

**The headset jack locations described below are typical for a 4- or 5-place configuration.**

a. The pilot and passenger #4 headset jacks (HDST PLT and HDST PASS) are located on the upper left side of the cabin backwall. The co-pilot headset jack (HDST CO-PLT) is located on the right side of the cabin behind the co-pilot seat near the floor. Passenger #1 (co-pilot seat position) headset jack (HDST PASS) is located on the right side of the lower console. Passenger #2 and passenger #3 headset jacks (HDST PASS) are located on the upper right side of the cabin backwall.

### NOTE

**Noise-cancelling powered headsets must be switched to ON.**

2. Volume Adjustment. Refer to the specific model headset, ICS/VOX or audio panel operation manual for volume adjustment.

## CHAPTER 8. HANDLING, SERVICING, AND MAINTENANCE

### TABLE OF CONTENTS

<u>SECTION</u>	<u>DESCRIPTION</u>	<u>PAGE</u>
	Table of Contents .....	8-1
Section I	General .....	8-3
Paragraph	8-1 Location of Servicing Points .....	8-3
	8-2 Servicing Table .....	8-3
Section II	Fuel .....	8-4
Paragraph	8-3 Fuel Types.....	8-4
	8-4 Use of Fuels .....	8-4
	8-5 Fuel System Servicing .....	8-6
Section III	Engine and Transmission.....	8-10
Paragraph	8-6 Engine Oil System Servicing.....	8-10
	8-7 Main Rotor Transmission and Tail Rotor Transmission Servicing .....	8-11
Section IV	Drive System.....	8-12
Paragraph	8-8 Lower Pulley Bearing Housings	8-12
	8-8.1 Overrunning Clutch .....	8-12
Section V	Main Rotor Hub .....	8-13
Paragraph	8-9 Main Rotor Flapping Bearings ..	8-13
Section VI	Landing Gear .....	8-14
Paragraph	8-10 Landing Gear Oleos.....	8-14
Section VII	Ground Operations .....	8-25
Paragraph	8-11 Ground Handling .....	8-25
	8-12 External Power .....	8-26
	8-13 Parking .....	8-26
	8-14 Snow and Ice Removal.....	8-27

**CHAPTER 8. HANDLING, SERVICING, AND  
MAINTENANCE****LIST OF FIGURES**

<u>FIGURE NO.</u>	<u>DESCRIPTION</u>	<u>PAGE</u>
8-0	Overrunning Clutch Servicing .....	8-12.2
8-1	Servicing Locations .....	8-15
8-2	Landing Gear Oleo Condition Placard..	8-18

**LIST OF TABLES**

<u>TABLE NO.</u>	<u>DESCRIPTION</u>	<u>PAGE</u>
8-1	Landing Gear Oleo Condition Placard..	8-14
8-2	Fuels, Lubricants, Specifications and Capacities .....	8-19
8-3	Approved Commercial Oils .....	8-21
8-4	Approved Primary, Emergency and Cold Weather Fuels .....	8-23

## CHAPTER 8

### HANDLING, SERVICING AND MAINTENANCE

#### SECTION I. GENERAL

##### 8-1. Location of Servicing Points

1. Servicing points are shown in Figure 8-1.

##### 8-2. Servicing Table

1. Refer to Table 8-2 for fuel, lubricants, specifications, and capacities. Refer to Table 8-3 for approved commercial oils.

#### NOTE

**Refer to TH-28/480 Series Maintenance Manual, Section 4, for detailed service and lubrication requirements.**

## SECTION II. FUEL

### 8-3. Fuel Types

1. The primary, emergency and cold weather fuels which can be used in the 480B helicopter are presented in Table 8-4. The following definitions apply to the approved fuels table.

2. Primary Fuels. These are the designated primary fuels adopted for worldwide use.

3. Emergency Fuels. These are fuels which can be used if primary fuels are not available. Their use is usually subject to a specific time limit.

4. Cold Weather Fuels. These fuels may be required to assure consistent starts at ambient temperatures below 4°C (40°F). There is no restriction from operating the aircraft on any primary fuels at ambient temperatures down to -32°C (-25°F), however, special provisions may be required to start the engine. (Refer to the Rolls-Royce 250-C20 Series Operation and Maintenance Manual for further information.)

### 8-4. Use of Fuels

#### NOTE

**At ambient temperatures below 4°C (40°F), all fuels used shall contain Anti-Icing Additive conforming to MIL-DTL-85470. The Anti-Icing Additive shall be added to all commercial fuel, not already containing an anti-icing additive, during refueling operations. Refueling operations shall be accomplished in accordance with accepted commercial procedures. Commercial product PRIST® HI-FLASH™ conforms to MIL-DTL-85470.**



---

## CAUTION

---

**Avoid using anti-icing additives packaged in aerosol cans. Failure to exactly follow the additive mixing procedures during refueling can result in incorrect additive concentrations, fuel system contamination, and possible engine stoppage.**

1. There is no special limitation on the use of primary fuel, but certain limitations are imposed when emergency fuels are used. For the purpose of recording, fuel mixtures shall be identified as to the major component of the mixture, except when the mixture contains leaded gasoline. A fuel mixture which contains over 10% leaded gasoline shall be recorded as all leaded gasoline. The use of any fuels other than standard will be recorded in the Aircraft Maintenance and Inspection Record, noting the type of fuel, additives, and duration of operation.

2. The use of kerosene fuels, (JP-5 type), in turbine engines dictates the need for observance of special precautions. Both ground starts and air starts at low temperature (below 5°C) may be more difficult due to low vapor pressure. Kerosene fuels having a freezing point of -40°C or -53°C should be used with caution when the operational temperatures at the intended flight altitude approach those values and either standard fuels sought or the maximum altitudes for the intended operation limited.

3. **Mixing of Fuels.** When changing from one type of authorized fuel to another, for example JET A to JP-5, it is not necessary to drain the helicopter fuel system before adding the new fuel.

## 8-5. Fuel System Servicing

1. Precautions in Fuel Servicing and Defueling

---

### CAUTION

---

**Observe the following precautions in all fuel servicing and defueling operations as applicable:**

- a. Position auxiliary ground power units on the windward side of the helicopter.
- b. Do NOT fuel or defuel during electrical storms.
- c. Do not fuel or defuel while ground radar sets are operating within 300 feet/92 meters of the helicopter.
- d. Servicing personnel shall not wear metal taps on their shoes.
- e. Be sure that the battery switch is in the OFF position and external power is disconnected before fueling or defueling the helicopter.
- f. Ground the helicopter at the receptacle located on the top of the left engine access panel to the filler nozzle before removing the filler cap.

- g. The fuel truck shall be grounded (truck to ground and truck to helicopter). The helicopter shall be grounded to the same ground point as is the fuel truck.
  - h. Observe the anti-icing additive manufacturer's instructions when adding anti-icing additives to fuel that is not "premixed" with anti-icing additives.
  - i. After completion of servicing, wash down and remove any spillover of jet fuel. This fuel does not evaporate as rapidly as gasoline and constitutes a fire hazard for a much longer time. Cleaning materials or clothing which have become saturated with jet fuel shall be disposed of properly.
2. Servicing
    - a. Ground the aircraft, truck, and nozzle.
    - b. Remove the fuel cap.

---

**CAUTION**

---

**Insert nozzle carefully in a generally downward direction, avoiding contact with the inside of the fuel cell. Fuel nozzles must be hand held during servicing.**

- c. Position the nozzle into the fuel cell filler neck.

**WARNING**

**In the event of major spillage of fuel, all powered equipment shall be shut down. All personnel shall leave the vicinity and be positioned to prevent any sources of possible ignition from entering the area. The appropriate authorities shall be summoned to the area to contain and disperse the spill.**

- d. Fill to the specified level.

**NOTE**

**Refer to Table 8-2 for fuel tank capacity.**

- e. Remove the nozzle and replace the fuel cap.
  - f. Disconnect the nozzle ground and rewind hose.
  - g. Disconnect the truck and helicopter grounds.
3. Defueling

**NOTE**

**Refer to the TH-28/480 Maintenance Manual for specific maintenance procedures.**

**WARNING**

**In the event of a major spillage of fuel, all powered equipment must be shut down. All personnel should leave the vicinity and be positioned to prevent any sources of possible ignition from entering the area. The appropriate authorities should be notified to contain and disperse the spill.**

- a. Pull fuel shutoff hand **OFF**.
- b. Open the left side engine access panel.

**CAUTION**

**Cap all open lines/fittings to prevent contamination of the systems.**

- c. Disconnect the fuel supply line at the engine fuel pump.

**NOTE**

**Drain the fuel into suitable containers if not using a defueling vehicle.**

- d. Connect the line to the suction pickup of the defueling vehicle.
- e. Remove the fuel cell cap.
- f. Push the fuel shutoff handle **ON**.
- g. Defuel the aircraft.
- h. Disconnect the defueling vehicle and reconnect the fuel supply line to the engine.

**NOTE**

**Standard fuel cells will retain approximately 1 gallon (3.8 l) of fuel due to the foam baffling installed in the fuel cells. This fuel can be drained from the cells after defueling the aircraft and letting the aircraft stand for a 24 hour period.**

- i. Drain the remaining fuel from the aircraft via the fuel cell sump drains and the low point drain.

### SECTION III. ENGINE AND TRANSMISSION

#### 8-6. Engine Oil System Servicing

1. The engine oil tank is located on the right side of the aircraft behind the right engine access panel. Oil level is checked by removing the oil reservoir filler cap and observing the integral metal dip stick attached to the cap. Oil level should be checked within 15 minutes of engine shutdown. Refer to Table 8-2 for the capacity and the authorized oil.

2. The aircraft can be operated with either MIL-PRF-7808 (formerly MIL-L-7808) or MIL-PRF-23699 (formerly MIL-L-23699) oil. MIL-PRF-23699 is preferred for operation at ambient temperatures above -18°C (0°F). Table 8-3 lists the commercial products available which are approved for use in the engine.

#### WARNING

**Mixing of oils from different series (MIL-PRF-7808 with MIL-PRF-23699) is permitted only in an emergency. The use of such mixed oils is limited to five hours total running time. Refer to the Rolls-Royce 250-C20 Series Operation and Maintenance Manual.**

#### CAUTION

**Refer to the Rolls-Royce 250-C20 Series Operation and Maintenance Manual for information concerning use and mixing of approved turbine engine oils in the Rolls-Royce 250-C20W.**

## **8-7. Main Rotor Transmission and Tail Rotor Transmission Servicing**

1. Main Rotor Transmission. A sight glass located on the aft right side of the transmission housing can be viewed through the upper maintenance step kick-in panel located on the right side of the aircraft. The oil level must be visible in the lower one half of the sight glass. If oil is visible, no additional oil is required. If oil is not visible, add oil until the oil is half way up the sight glass. The oil service tube for the main rotor transmission is located forward and to the right of the main rotor mast. It is accessed via the opening in the top of the air duct in front of the main rotor mast. Refer to Table 8-2 for the capacity and the authorized oil. Table 8-3 lists the commercial products available which are approved for use in the main rotor transmission.

2. Tail Rotor Transmission. A sight glass is provided on the aft side of the transmission. Minimum oil level is the middle of the sight glass. If required, add oil until there is just barely a small bubble at the top of the sight glass with the aircraft sitting fairly level. The filler port for the transmission is located above the sight glass. Lockwire the filler plug and sight glass together after servicing the transmission. Refer to Table 8-2 for capacity and authorized oil. Table 8-3 lists the commercial products available which are approved for use in the tail rotor transmission.

### **NOTE**

**The quantity of oil used to service the transmission after an oil change will completely fill the sight glass. A small bubble will not be visible in the sight glass unless the aircraft is positioned in a tail high attitude.**

## SECTION V. DRIVE SYSTEM

### 8-8. Lower Pulley Bearing Housings

1. A sight glass is provided in the lower pulley bearing housings to determine the oil level in the bearing housings. The sight glasses are located behind the left side engine access panel. The oil level in the bearing housings must be visible in the lower one half of the sight glass. Refer to Table 8-2 for the capacity and the authorized oil. Table 8-3 lists the commercial products available which are approved for use in the lower pulley bearing housings. If oil is visible then no additional oil is required. If oil is not visible, use the following procedure to service the lower pulley bearing housings.

- a. Remove the service plug(s) located above the temperature probe on the opposite side of the bearing housing(s).
- b. Add oil until the oil is half way up the sight glass.
- c. Reinstall the service plug(s).

#### 8-8.1. Overrunning Clutch

1. A sight glass is incorporated into the overrunning clutch cover to determine the oil level in the overrunning clutch (Refer to Figure 8-0). Access to the sight glass is through the left side engine access panel.

2. For aircraft equipped with a vented clutch oil reservoir, a sight glass is incorporated into the reservoir container (Refer to Figure 8-1). Access to the reservoir sight glass is through the left side engine access panel. Since the oil reservoir sight glass and the overrunning clutch cover sight glass are at the same height, the oil level should be the same.

3. If oil fills sight glass(es) then no additional oil is required.



4. If the sight glass is not full of oil, and the aircraft is not equipped with a vented clutch oil reservoir, use the following procedure to service the overrunning clutch (Refer to Figure 8-0). Refer to Table 8-2 for the capacity and the authorized oil. Table 8-3 lists the commercial products available which are approved for use in the overrunning clutch.

- a. Open the left side engine access panel.
- b. Rotate the clutch until one of the cap plugs is at the 12 o'clock position (as seen by looking aft) and remove the plug.
- c. Slowly rotate the clutch clockwise until oil drains from the port. Note the position of the oil level. The clutch is properly serviced if the level is between the 12:00 and 3:00 positions.
- d. Service the clutch by rotating the port to the 12:00 position and slowly adding oil with a squirt can/syringe until oil flows from the port. Reinstall the plug and lockwire (.025").
- e. Wipe up the excess oil.

5. If the clutch cover sight glass and the reservoir sight glass are not full of oil, service the overrunning clutch via the service port on the reservoir container. Slowly add oil to just below the service port (Refer to Figure 8-0). Ensure sufficient time for the oil to flow to the ORC. Refer to Table 8-2 for the capacity and the authorized oil. Table 8-3 lists the commercial products available which are approved for use in the overrunning clutch.

#### NOTE

**Corrective maintenance action is required if the overrunning clutch requires servicing after less than 10 hours of flying. Refer to the TH-28/480 Series Maintenance Manual for corrective action requirements.**

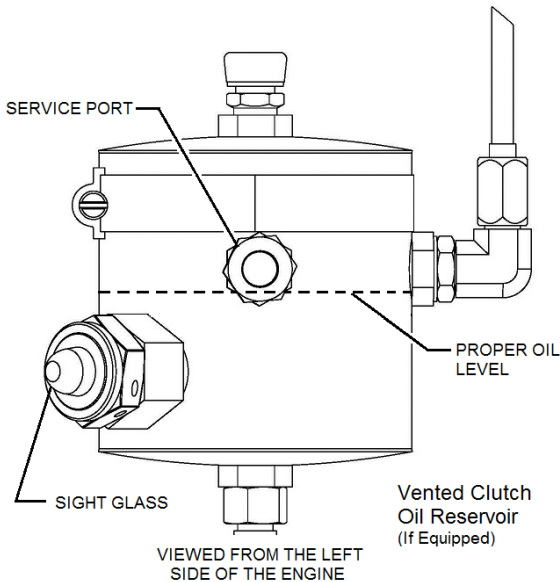
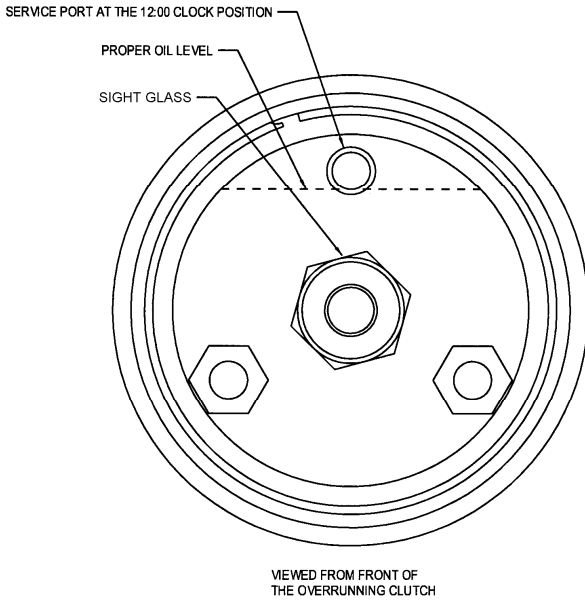

Figure 8-0. Overrunning Clutch Servicing

## SECTION V. MAIN ROTOR HUB

### 8-9. Main Rotor Flapping Bearings

1. The reservoirs for the main rotor flapping bearings are located on top of the main rotor hub. The oil level in the reservoirs should be between the top of the dust cover and three quarters ( $\frac{3}{4}$ ) full. Refer to Table 8-2 for the capacity and the authorized oil. Service the flapping bearing reservoirs using the following procedure.

- a. Remove the reservoir cap and replace the O-ring (internal thread reservoir) or seal (external thread reservoir) as required.
- b. Fill the reservoir until the reservoir is half ( $\frac{1}{2}$ ) to three quarters ( $\frac{3}{4}$ ) full.
- c. Install the cap until the O-ring or seal on the cap contacts the reservoir. Tighten the O-ring equipped cap an additional one half ( $\frac{1}{2}$ ) turn **maximum** by hand. Torque the seal equipped cap 10-20 in-lb/1.1-2.3 Nm or tighten an additional one sixteenth ( $\frac{1}{16}$ ) turn **maximum** by hand.

### CAUTION

**Do not overtighten caps.**

### NOTE

**Corrective maintenance action is required if the reservoir(s) is/are empty after four (4) hours of flying.**

**SECTION VI. LANDING GEAR****8-10. Landing Gear Oleos**

1. Check the landing gear oleos for proper inflation by observing the condition placard installed on the inboard side of the lower oleo fairings (Refer to Figure 8-2). The bottom edge of the upper oleo fairing is used as the indicator for determining the condition of the oleo.

**NOTE**

**The landing gear oleo condition placard should be used as a guide in determining the condition of the oleos. Factors such as optional equipment, loaded baggage, ambient temperature, and the surface the aircraft is parked on can affect the accuracy of the placard indications.**

2. Refer to Table 8-1 for condition/corrective action information related to the condition placard.

3. Refer to the TH-28/480 Series Maintenance Manual when the landing gear oleos require servicing.

**NOTE**

**To prevent erroneous indications of the aft oleos, lift up on the end of the tail cone to redistribute the weight of the aircraft if the aircraft has been moved using the ground handling wheels.**

**Table 8-1. Landing Gear Oleo Condition Placard**

<b>COLOR</b>	<b>CONDITION/CORRECTIVE ACTION</b>
GREEN	SERVICEABLE - NO CORRECTIVE ACTION
YELLOW	SERVICEABLE - MAY REQUIRE SERVICING IN THE NEAR FUTURE
RED	UNSERVICEABLE - REQUIRES SERVICING

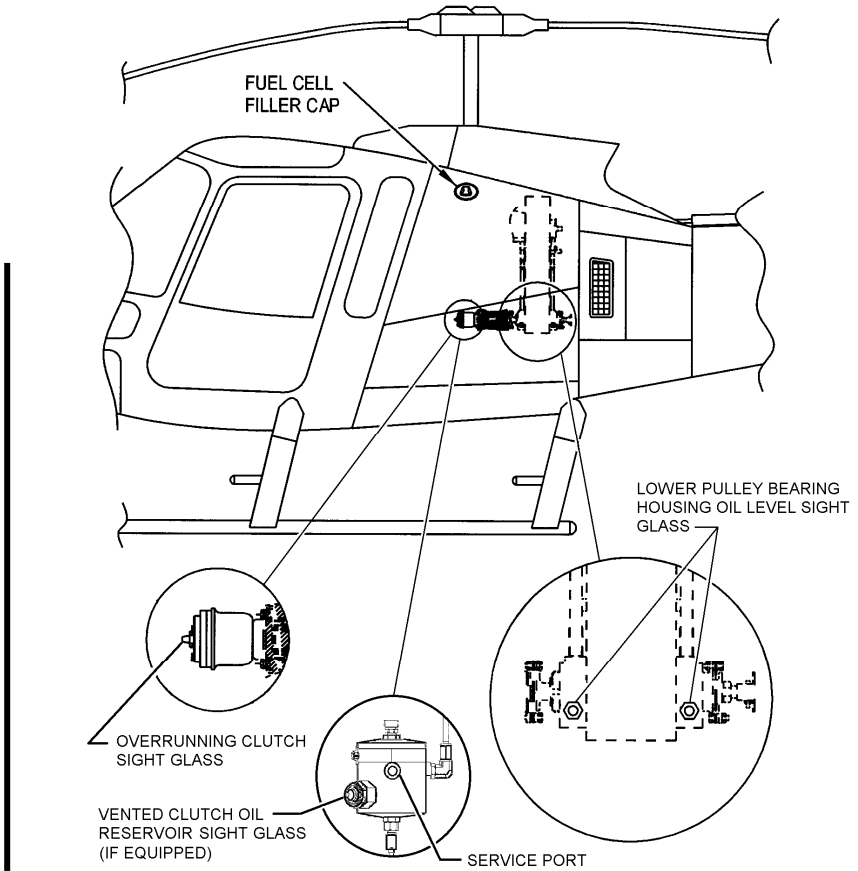

Figure 8-1. Servicing Locations

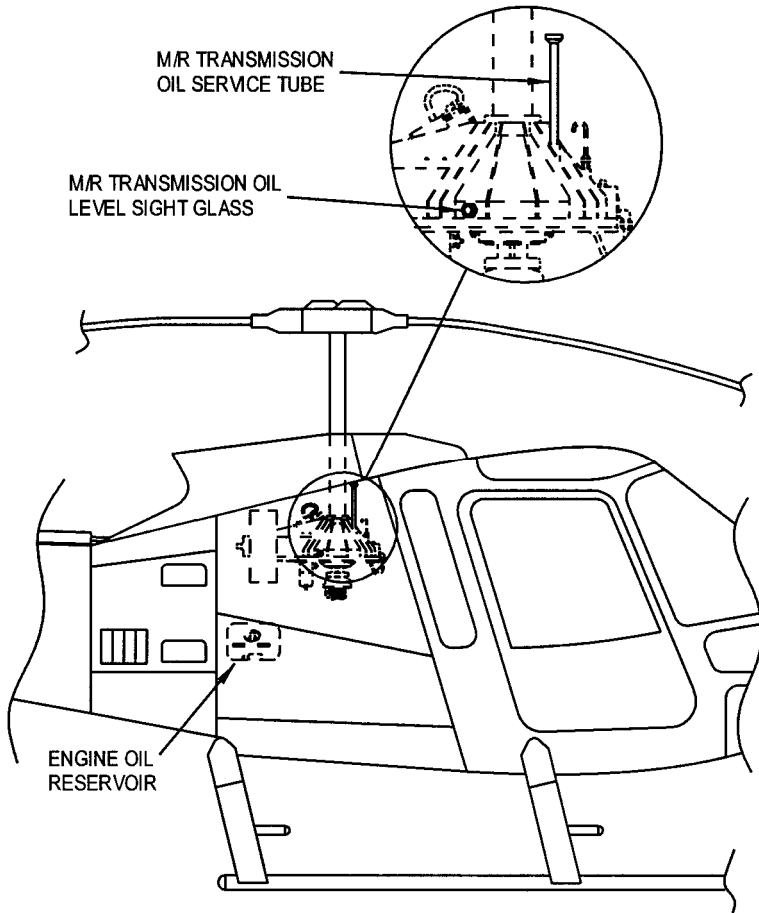
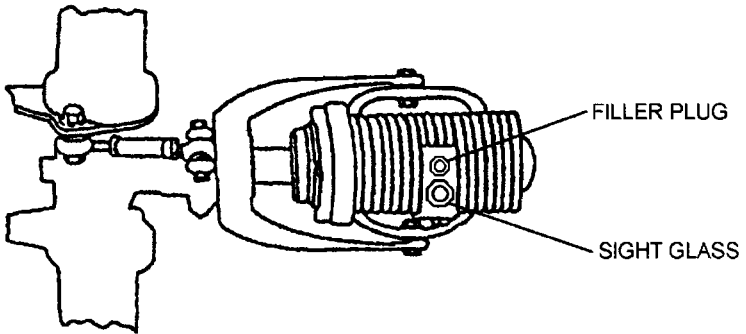

Figure 8-1. Servicing Locations



TAIL ROTOR TRANSMISSION - LOOKING FORWARD

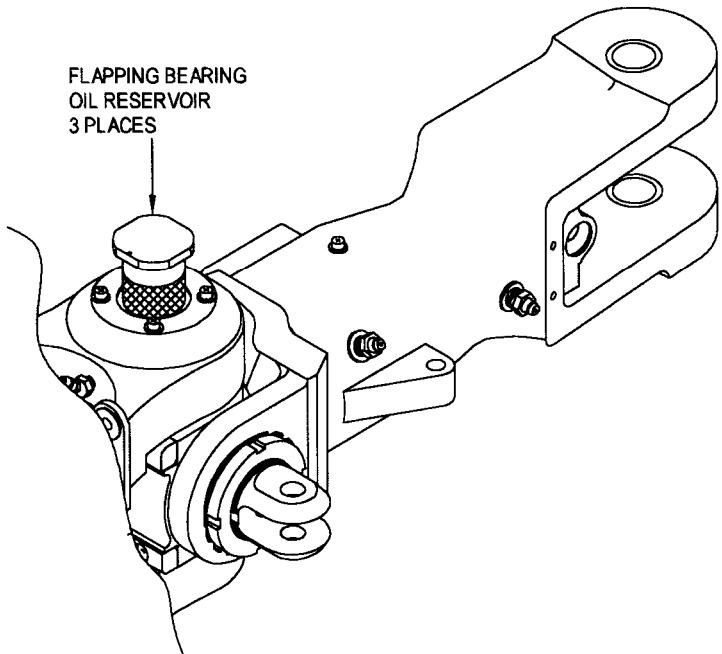

Figure 8-1. Servicing Locations



Figure 8-2. Landing Gear Oleo Condition Placard



**Table 8-2. Fuels, Lubricants, Specifications, and Capacities**

<b>SYSTEM</b>	<b>SPECIFICATION</b>	<b>CAPACITY</b>
Fuel - Standard	ASTM D1655 Jet A or A1 ASTM D6615 Jet B MIL-DTL-5624 JP-4 & JP-5 MIL-DTL-83133, Grade JP-8 (See Notes 1, 2, and 3)	91.7 U.S. Gals (90.0 usable)  347.08 liters (340.65 usable) (See Note 4)
Fuel - Crashworthy	ASTM D1655 Jet A or A1 ASTM D6615 Jet B MIL-DTL-5624 JP-4 & JP-5 MIL-DTL-83133, Grade JP-8 (See Notes 1, 2, and 3)	90 U.S.Gals (89.7 usable)  340.7 liters (339.5 usable) (See Note 4)
Engine Oil	MIL-PRF-7808 MIL-PRF-23699 (See Note 5)	12 U.S. Pints 5.7 liters
Overrunning Clutch	MIL-PRF-23699 (See Table 8-3)	3.8 U.S. Ounces 110 ml
Overrunning Clutch with Vented Clutch Oil Reservoir (If Equipped)	MIL-PRF-23699 (See Table 8-3)	6.5 U.S. Ounces 192 ml
Main Rotor Transmission	MIL-PRF-2105/API GL-5 (See Table 8-3)	6 U.S. Pints 2.84 Liters
Tail Rotor Transmission	MIL-PRF-2105/API GL-5 (See Table 8-3)	5 U.S. Ounces 150 ml
Main Rotor Flapping Bearings	MIL-PRF-23699 (See Table 8-3)	As Required
Lower Pulley Bearings	MIL-PRF-23699 (See Table 8-3)	.27 U.S. Ounces 8 ml

**NOTES:**

1. Refer to Table 8-4 and the Rolls-Royce 250-C20 Series Operation and Maintenance Manual (10W2) for a complete listing of the approved Primary, Emergency, and Cold Weather fuels.

2. MIL-G-5572 fuel containing tricresylphosphate shall not be used.

3. At ambient temperatures below 4°C (40°F), all fuels used shall contain Anti-Icing Additive conforming to MIL-DTL-85470. The Ant-Icing Additive shall be added to all commercial fuel, not already containing an anti-icing additive, during refueling operations. Refueling operations shall be accomplished in accordance with accepted commercial procedures. Commercial product PRIST® HI-FLASH™ conforms to MIL-DTL-85470.

### CAUTION

**Avoid using anti-icing additives packaged in aerosol cans. Failure to exactly follow the additive mixing procedures during refueling can result in incorrect additive concentrations, fuel system contamination, and possible engine stoppage.**

4. The fuel cells for the standard fuel system are designed for a total capacity of 91.7 gallons (347.08 l) and the fuel cells for the crashworthy fuel system are designed for a total capacity of 90 gallons (340.65 l); however, differences in baffle installation in both the standard and crashworthy fuel system will result in a slight variance in total fuel capacity between aircraft.

5. The following is the recommended oil for the specified average daily temperatures:

Outside Temperature	Recommended Oil
0°C (32°F) and above	MIL-PRF-23699 preferred
0°C (32°F) to -40°C (-40°F)	MIL-PRF-23699 preferred or MIL-PRF-7808
-40°C (-40°F) and below	MIL-PRF-7808

**Table 8-3. Approved Commercial Oils  
MIL-PRF-7808**

<b>MANUFACTURER</b>	<b>MANUFACTURER'S DESIGNATION</b>
Air BP Lubricants	BP Turbo Oil 2389
American Oil	American PQ Lubricant 689
Castrol Inc.	Brayco 880
Exxon Mobil Oil	Mobil Avrex S Turbo 256, Mobil RM-201A, or Mobil RM-184A
Stauffer Chemical	Stauffer Jet 1

**MIL-PRF-23699**

<b>MANUFACTURER</b>	<b>MANUFACTURER'S DESIGNATION</b>
Mobil Oil	Mobil Jet Oil II
NYCO America	Turboycoil 600 (TN600)
Anderol Specialty Lubricants	Aeroshell/Royco Turbine Oil 500
American Oil and Supply Co.	American PQ Lubricant 6700
Castrol Inc.	Brayco 899
Hatcol Corporation	Hatcol 3211
Air BP Lubricants, Inc.	BP Turbo Oil 2380
Stauffer Chemical	Stauffer Jet II (Castrol 205)
Caltex Petroleum Corp.	Caltex RPM Jet Engine Oil 5
Chevron International Oil Co.	Chevron Jet Engine Oil 5
Exxon Mobil Corp.	Mobil Jet Oil 254 (Generation 3/HTS Oil)
Anderol Specialty Lubricants	Royco Turbine Oil 560 (Generation 3/HTS Oil)
Shell Oil Co.	Aeroshell Turbine Oil 560 (Generation 3/HTS Oil)

**Table 8-3. Approved Commercial Oils (Continued)****MIL-PRF-2105 Series/API GL-5**

<b>MANUFACTURER</b>	<b>MANUFACTURER'S DESIGNATION</b>
Exxon Mobil Corp.	Mobil 1 <sup>®</sup> Synthetic Gear Lubricant LS 75W-90 Mobilube HD <sup>®</sup> LS 80W-90 Mobilube HD <sup>®</sup> Plus 80W-90 Mobilube SHC <sup>®</sup> 75W-90
Shell Oil Company	Shell Spirax <sup>®</sup> S Gear Lubricant 75W-90 Shell Spirax <sup>®</sup> HD 80W-90
Esso	Esso Gear Oil GX 75W-90 Esso Gear Oil GX Extra 75W-90
BP Lubricants USA, Inc.	Syntorq GL-5 75W Castrol Syntrex Limited Slip 75W-90 (Syntec Gear Oil)

**Table 8-4. Approved Primary, Emergency and Cold Weather Fuels**

TYPE	SPECIFICATION	LIMITATIONS
Primary	ASTM D1655 Jet A or A1 ASTM D6615 Jet B MIL-DTL-5624 JP-4 & JP-5 MIL-DTL-83133 JP-8 GOST 10227 Grade TS-1 or RT (Russia) STAS 5639-88, Grade TH (Romania) GB 6537, Grade No. 3 (Peoples Republic of China) GSTU 320.00149943.007-97 Grade -RT(PT) (Ukraine) GSTU 320.00149943.007-99 Grade -TS-1(TC-1) (Ukraine)	With anti-ice additive <b>(See Note below)</b>
Emergency	ASTM D910 AVGAS (without TCP)	All Grades, Maximum 6 hours operation per overhaul period. With anti-ice additive
Cold Weather	MIL-DTL-5624 JP-4 ASTM D6615 Jet B ASTM D910 AVGAS-Jet fuel mixture <b>(See Note below)</b>	With anti-ice additive

**NOTE**

**At ambient temperatures below 4°C (40°F), all fuels used shall contain Anti-Icing Additive conforming to MIL-DTL-85470. The Ant-Icing Additive shall be added to all commercial fuel, not already containing an anti-icing additive, during refueling operations. Refueling operations shall be accomplished in accordance with accepted commercial procedures. Commercial product PRIST® HI-FLASH™ conforms to MIL-DTL-85470.**

**NOTE**

The AVGAS-jet fuel mixture is an alternate fuel which may be used if starting problems are encountered in areas where JP-4 or commercial Jet B cannot be obtained. The mixture shall be one part by volume AVGAS to two parts by volume commercial jet fuel. The AVGAS shall conform to ASTM D910, grades 80, 91, or 100LL with a maximum of 0.53 ml/liter maximum lead content. Do Not use ASTM D910 grade 100 with 1.06 ml/liter lead content. The commercial jet fuel may be JP-5, Jet A, or A1.

---

**CAUTION**

---

Avoid using anti-icing additives packaged in aerosol cans. Failure to exactly follow the additive mixing procedures during refueling can result in incorrect additive concentrations, fuel system contamination, and possible engine stoppage.

## SECTION VII. GROUND OPERATIONS

### 8-11. Ground Handling

1. A set of ground handling wheels is provided for moving the aircraft on the ground. The ground handling wheels attach to the skids at the lugs provided near the aft oleo struts. The wheels are an over center type. The wheels must be removed from the skids prior to flight.

#### NOTE

**Do not ground handle by pushing or pulling on the stabilizers or by pushing on the nose of the cabin.**

2. Ground Handling Wheel Installation

#### WARNING

**Use extreme caution when installing and removing the ground handling wheels to prevent injury to personnel and to prevent from damaging the aircraft.**

- a. Remove the safety pin from the ground handling wheel assembly and install the wheel assembly onto the mount lugs on the top of the skid tube. Insert the safety pin into the ground handling wheel assembly.
- b. Support the aircraft at the tail rotor guard.
- c. Insert the wheel bar into the wheel and lower the wheel by pulling towards the front of the aircraft. Ensure the over-center lock is engaged. Remove the wheel bar from the wheel. Repeat the process for the opposite wheel.

- d. Raise the wheel by inserting the wheel bar into the wheel. Release the over-center lock and carefully move the bar towards the aft end of the aircraft. Remove the bar from the wheel.
3. Remove the ground handling wheels by reversing the installation procedure.

### **8-12. External Power**

1. A 28-volt DC unit with a minimum output of 300 amperes is required for starting.
2. Turn the helicopter battery and Generator switches OFF.
3. Turn the external power **OFF**.
4. Plug the external power source cable securely into the external power receptacle.
5. Turn the external power source **ON**.
6. Turn the helicopter battery switch **ON**.

### **8-13. Parking**

1. Retract the ground handling wheels and remove, allowing the helicopter to rest on its skids.
2. Install the main rotor tie down.
3. Install static ground.
4. Install the main rotor hub cover.
5. Install the tail rotor gearbox and hub cover.



## 8-14. Snow and Ice Removal

1. Remove all ice and snow accumulations from the top of the cabin, the top of the fuselage adjacent to and forward of the inlets, and from both inlet particle separator swirl tube assemblies prior to any flight.

2. The best method of unblocking swirl tubes blocked by snow is to pull the aircraft into a heated hangar, open the rear inspection panel on the upper plenum, and use a heat gun on LOW heat to blow from the inside of the plenum back through the swirl tubes until all snow has melted. Shop air can then be used to gently blow remaining moisture from the inside toward the outside of the swirl tube panel. DRY OFF the rest of the fuselage and blades and observe the following CAUTION for resumed operation:

---

### CAUTION

---

**Install covers over the blades and inlets prior to moving the aircraft from a heated hangar out into any precipitation where the outside air temperature is at or below freezing. Let the aircraft cool for at least 30 minutes before removing all covers for flight. Remove all ice and snow that has built up on the fuselage before removing covers. Minimize any delays in starting the engine and rotor after removing all covers to prevent snow from re-accumulating on the fuselage and flying surfaces.**

**INTENTIONALLY LEFT BLANK**

**CHAPTER 9. SUPPLEMENTAL INFORMATION**

**TABLE OF CONTENTS**

<u>SECTION</u>		<u>DESCRIPTION</u>	<u>PAGE</u>
		Table of Contents .....	9-1
Section I		General .....	9-3
Paragraph	9-1	Starting .....	9-3
	9-2	Engine Starting .....	9-3
	9-3	Oil Consumption .....	9-3
	9-4	Control Movements .....	9-3
	9-5	Slope Landings .....	9-3
	9-6	Minimum Transient Rotor Speed .....	9-4
	9-7	Flight Over Salt Water .....	9-4
Section II		Flight Characteristics .....	9-6
Paragraph	9-8	Operating Characteristics .....	9-6
	9-9	Retreating Blade Stall .....	9-6
	9-10	Settling with Power .....	9-7
	9-11	Loss of Tail Rotor Effectiveness...	9-8
	9-12	Ground Resonance .....	9-8

**LIST OF FIGURES**

<u>FIGURE NO.</u>	<u>DESCRIPTION</u>	<u>PAGE</u>
9-1	Average Engine Starting Time .....	9-5

**INTENTIONALLY LEFT BLANK**

## CHAPTER 9

### SUPPLEMENTAL INFORMATION

#### SECTION I. GENERAL OPERATION

##### 9-1. Starting

1. The helicopter can be started in a maximum wind velocity, including peak gusts, of 45 knots. The maximum gust spread is 15 knots.

##### 9-2. Engine Starting

1. Acceleration Time. The engine should start and accelerate to idle within the times shown in Figure 9-1. If the start time becomes significantly longer than those shown in Figure 9-1, consult maintenance personnel.

##### 9-3. Oil Consumption

1. The maximum oil consumption allowed is 0.05 gallons/hour at normal cruise rated power. If oil consumption increases, consult maintenance personnel.

##### 9-4. Control Movements

1. Abrupt control movements should be avoided, including rapid and repetitive anti-torque pedal reversal. This restriction in no way limits normal control application.

##### 9-5. Slope Landings

1. Slope landings have been demonstrated with the slope 90° either side of the nose up to a maximum of 15°.

---

#### CAUTION

---

**Caution must be exercised when landing on slopes that available cyclic travel is not exceeded. Also, if any droop stop pounding is encountered as the collective is lowered the landing must be aborted and a slope with less angle selected.**

## 9-6. Minimum Transient Rotor Speed

1. The minimum allowable transient rotor speed following engine failure or sudden power reduction for practice forced landing is 300 RPM. This is a transient limit and positive corrective action (lowering the collective) must be taken immediately by the pilot to regain at least 334 RPM (minimum power off rotor RPM). Lowering the collective to full down will quickly restore rotor RPM to the normal operating range under most flight conditions. Throttle chops or engine failure from the high hover point on the Height-Velocity (H-V) curve, along with the forward cyclic displacement required to achieve 20° nose down attitude for recovery, may result in the rotor speed decreasing below the minimum power off rotor RPM limit but not below the minimum transient limit of 300 rotor RPM. The (H-V) curve was developed taking this characteristic into account so that proper energy is available to return the rotor to the normal operating range prior to touchdown.

## 9-7. Flight Over Salt Water

1. Salt spray in turbine engines may result in a deterioration in performance as well as a loss in compressor stall margin. Flight in a salt water environment below 500 feet/152 meters AGL and near a large body of salt water will also have an impact on engine health. Following any exposure to a salt water environment, ie. hovering over salt water or flight operations within 5 nautical miles of an ocean coastline below 500 feet/152 meters AGL, appropriate entries should be made in the aircraft log book reflecting flight altitudes, duration of exposure, and other pertinent information so that maintenance personnel can perform an engine compressor wash and rinse the airframe with fresh water.

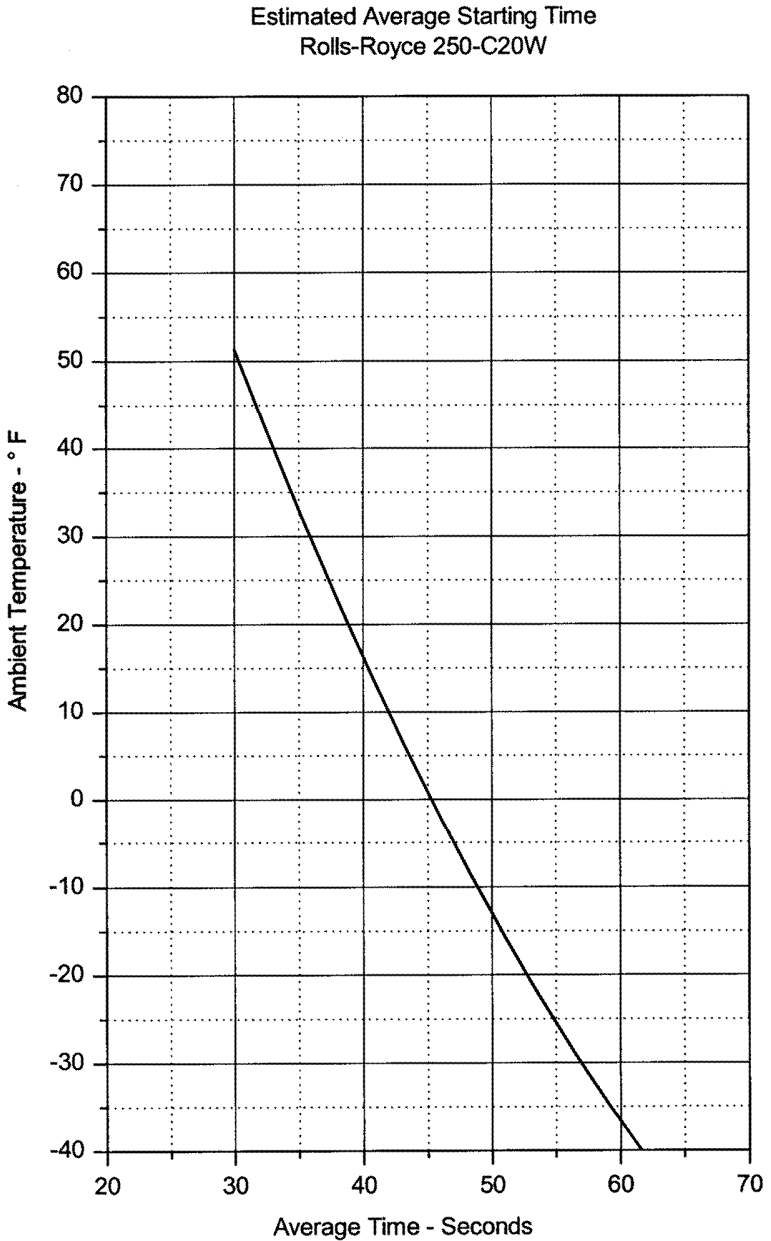

Figure 9-1. Average Engine Starting Time

## SECTION II. FLIGHT CHARACTERISTICS

### 9-8. Operating Characteristics

1. The flight characteristics of this helicopter, in general, are similar to other single rotor helicopters. This helicopter is capable of hovering in winds from any azimuth up to 35 knots.

### 9-9. Retreating Blade Stall

1. Blade stall occurs at higher forward speeds when a portion of the retreating blade stalls because of the reduced relative velocity of airflow over the blade at high blade angles. When the airspeed of the tip of the retreating blade falls below a predetermined value, or when a relative blade angle exceeds a predetermined value, blade stall will be experienced. If blade pitch is increased (as with increased collective or forward cyclic control), or if the forward speed is increased, the stalled portion of the rotor disc increases, and the stall progresses from the tip toward the root of the retreating blade. During maneuvers that increase the g-load, such as sharp turns or high-speed flares from diving descents, where rapid application of collective or cyclic pitch control is involved, severe blade stall may be encountered. Severe blade stall may also be encountered in turbulent air by gust-induced load factors or corrective control applications by the pilot. In the stall condition, each main rotor blade will stall as it passes through the stall region, creating a three per rev vibration. When significant blade stall is encountered a mild roughness will be noted along with some cyclic control feedback that will cause the cyclic to have a tendency to displace aft of the trimmed position. The vibration due to the blade stall will increase as blade stall progresses, as will the requirement for forward force to maintain the cyclic in the initial trimmed position. Both of these cues should provide adequate warning that blade stall is being encountered. Severe turbulence or abrupt control movement at this point will increase the severity of the stall but will not cause any loss of control to occur. In this helicopter, there is not as pronounced a tendency for the fuselage to pitch up and roll left in response to the rotor stalling as may be



experienced in other helicopters, but if the rotor is held in a stalled condition and the blade stall is aggravated, the helicopter will eventually exhibit this pitch and roll tendency. Even though blade stall may be encountered, the helicopter is fully controllable even in severe blade stall because of the blade design and the high rotor control power inherent in this rotor design. Blade stall may be eliminated by any or all of the following actions:

- a. Gradually decrease the severity of the maneuver.
- b. Gradually decrease collective pitch.
- c. Gradually decrease airspeed.
- d. Increase the rotor speed to maximum power on RPM by keeping the engine to 103%  $N_2$ .

## 9-10. Settling With Power

---

### CAUTION

---

**Flight conditions causing settling with power should be avoided at low altitudes because of the loss of altitude necessary for recovery.**

1. Settling with power may occur when a helicopter is flown at low airspeeds, using a high power setting at relatively low rates of descent. Under this condition, the helicopter is settling through the air displaced by its own rotor system. The downwash then recirculates through the helicopter rotor system and results in reduced rotor efficiency. This condition can be recognized by increased roughness accompanied by a rapid build up in rate of descent. Increasing collective pitch only tends to aggravate the situation. Recovery from settling with power can best be made by increasing forward speed and decreasing collective pitch. A considerable loss of altitude may occur before the condition is recognized and recovery completed. During approach for landings at high gross weights, conditions associated with settling with power should be avoided.

## 9-11. Loss of Tail Rotor Effectiveness

1. Loss of tail rotor effectiveness (LTE) is a phenomenon which can occur in any single main rotor/anti-torque tail rotor helicopter. Although the 480B has a very effective tail rotor and does not exhibit any tendencies for LTE, the pilot should be aware that the potential for LTE, however small, does exist. As such, pilots should be aware of the causes and recovery techniques. There are a number of factors which reduce the effectiveness of the tail rotor or increase the thrust required from the tail rotor. These factors include high power settings, low airspeeds, left crosswinds or tailwinds, and right, yawing turns. Under exactly the right conditions, these factors can combine to make the tail rotor virtually ineffective. This LTE can be recognized by an uncommanded right yaw which can not be stopped using the tail rotor pedal alone. Recovery from LTE can be accomplished by increasing forward speed, lowering the collective if altitude permits, and applying left pedal. The longer corrective actions are delayed, the more difficult it will be to recover from LTE.

## 9-12. Ground Resonance

1. Ground resonance is an aerodynamic phenomenon associated with fully articulated rotor systems. It develops when the rotor blades move out of phase with each other and cause the rotor disc to become unbalanced. The chance of encountering ground resonance in the 480B is very remote; however, the potential does exist if the main rotor dampers or oleo struts are severely degraded or damaged.

2. If severe vibrations are encountered on the ground when bringing the main rotor rpm up to operating speed, immediately turn the throttle to the flight idle position. If severe vibrations are encountered when the main rotor rpm is at operating speed, immediately hover the aircraft and allow the vibrations to dampen. Attempt to land the aircraft. If severe vibrations are encountered again, immediately hover the aircraft, allow the vibrations to dampen, and perform a hovering autorotation.

**CHAPTER 10. ABBREVIATED CHECK LIST**

**TABLE OF CONTENTS**

<u>SECTION</u>		<u>DESCRIPTION</u>	<u>PAGE</u>
		Table of Contents .....	10-1
Section I		General .....	10-3
Paragraph	10-1	General .....	10-3
	10-2	Abbreviated Checklist.....	10-5

**INTENTIONALLY LEFT BLANK**

## CHAPTER 10

### ABBREVIATED CHECKLIST

#### SECTION I. GENERAL

##### 10-1. General

1. The Abbreviated Checklist provides the pilot with a quick reference for abbreviated procedure information. Refer to Chapters 2 and 3 of this RFM for clarification and expansion of procedures.

2. The Abbreviated Checklist may be reproduced, cut to size, laminated as desired, and carried separately in the cockpit for quick reference.

3. If the Abbreviated Checklist is carried separately in the cockpit, the pilot in command is responsible for insuring that the Abbreviated Checklist is maintained with the latest revision of this RFM.

##### 10-2. Abbreviated Checklist

1. The Abbreviated Checklist begins on page 10-5.

**INTENTIONALLY LEFT BLANK**

# **ENSTROM 480B HELICOPTER**

## **Pilot's Checklist**

This is an Abbreviated Checklist.

See the Rotorcraft Flight Manual for Clarification and Expanded or Updated Procedures.

The pilot in command is responsible for insuring that this checklist is maintained with the latest revision of the Rotorcraft Flight Manual (RFM).

**INTENTIONALLY LEFT BLANK**



## HELICOPTER AND SYSTEMS

### ***BEFORE EXTERIOR CHECK***

1. Publications – Check.
2. Aircraft Tiedowns, Covers, Grounding Cables – Removed and Stowed.
3. BATT Switch – ON.
4. Fuel Quantity and Sample (see RFM) – Check.
5. Lights – Check.
6. BATT Switch – OFF.
7. Right Side Flight Controls – Check.
8. Co-Pilot/Passenger and Passenger Seat and Restraints – Check.
9. Pedals – Adjust.
10. Cargo – Check.
11. First Aid Kit – Check.
12. Fire Extinguisher – Check.

### ***EXTERIOR CHECK***

#### ***CABIN LEFT SIDE***

1. Landing Gear – Check.
- (O) 2. Cabin Door – Check.
3. Static Port – Check unobstructed.

**AFT FUSELAGE – LEFT SIDE**

1. Fuselage – Check.
2. Engine Compartment – Check.
  - a. Fuel cell & low point drain – Fuel sample and check.
  - b. Fuel lines – Check.
  - c. Flight controls – Check.
  - d. Engine – Check.
  - e. Fire detection pressure loop – Check.
  - f. Electrical wiring – Check.
  - g. Lower pulley bearings:
    - (1) Check condition and security.
    - (2) Check sight glass oil level.
  - h. Drive belt – Check.
  - i. Tail rotor cables – Check.
  - j. Engine fire curtain – Check.
  - k. M/R Xmsn oil filter – Check.
  - l. Overrunning clutch oil level – Check.
- (O) m. External fuel filter – Check impending bypass indicator (see RFM).
- (O) n. Cargo Hook Suspension Cables – Check.

- (O) o. Cargo Hook – Check condition and security.
- (O) p. Cargo Hook Manual Release Cable and Electrical Release Wiring – Check.
- (O) q. Cargo Hook Electrical Release – Check operation.
- (O) r. Cargo Hook Manual Release – Check operation.
- s. Engine compartment door – Secure.
- 3. Lower Engine Compartment Access panels – Secure.
- 4. Fuel – Check quantity, secure cap.
- 5. Engine Inlet and Plenum – Check.
- 6. Aft Landing Gear – Check.
- 7. Oil Cooler Air Intake – Unobstructed.
- 8. Baggage Compartment – Check.
- (O) 9. Snowshoes – Check condition and security.

### ***TAILCONE – LEFT SIDE***

- 1. Tailcone – Check.
- 2. Static Port – Check unobstructed.
- (O) 3. Antennas – Check.
- 4. Tail Rotor Drive Shaft Cover – Check.

5. Horizontal Stabilizer – Check.
6. Position and Strobe Lights – Check.
7. Vertical Stabilizer – Check.
8. Tail Rotor – Check.

### ***TAILCONE – RIGHT SIDE***

1. Tail Rotor Guard – Check.
2. Tail Rotor Gearbox – Check.
3. Tailcone Extension – Check.
4. Vibration Absorber – Check.
5. Tailcone – Check.
6. Horizontal Stabilizer – Check.
7. Position and Strobe Lights – Check.
8. Vertical Stabilizer – Check.
- (O) 9. Antennas – Check.
10. Static Port – Check unobstructed.

### ***AFT FUSELAGE – RIGHT SIDE***

1. Oil Cooler Exhaust – Check.
2. Aft Landing Gear – Check.
3. Engine Exhaust and Eductor – Check.

- | (O) 4. Lower anticollision light – Check.
- 5. Engine Compartment
  - a. Right fuel tank drain – Sample and check.
  - b. Fuel lines – Check.
  - c. Flight controls – Check.
  - d. Engine – Check.
  - e. Fire detection pressure loop – Check.
  - | f. Electrical equipment and wiring – Check.
  - g. Engine oil reservoir – Check.
  - h. Oil lines – Check.
  - i. Lower pulley restraint rods – Check.
  - j. Scavenge oil filter – Check.
  - k. Tail rotor cables – Check.
  - l. Engine fire curtain – Check.
  - | m. Throttle – at minimum position stop.
  - (O) n. Cargo Hook Suspension Cables – Check.
  - o. Engine compartment door – Secure.
- 6. Lower Engine Compartment Access Panels – Check.
- 7. Main Rotor Transmission Oil Level – Check.
- (O) 8. Snowshoes – Check condition and security.

**FUSELAGE – TOP**

1. Engine Inlet and Plenum – Check.
- (O) 2. Upper anticollision light – Check.
3. Upper Transmission Area – Check.
4. Main Rotor System – Check (see RFM).
5. Main Rotor Blades – Check.
6. Upper Pulley Area – Check upper pulley and tail rotor drive shafting.

**CABIN – RIGHT SIDE**

1. Static Port – Check unobstructed.
- (O) 2. Cabin Door – Check.
3. Forward Landing Gear – Check.

**CABIN – FRONT AREA**

1. Windshield – Check.
2. Pitot Tube – Check.
3. Landing Light – Check.
4. Fuselage Underside – Check.
- (O) 5. Main Rotor Blade Tape – Check condition and security on all three blades.

## ***BEFORE STARTING ENGINE***

1. KEY – IN and ON.
2. Passenger Briefing – Complete.
3. Seat Belts and Shoulder Harnesses – Secure.
4. Inertial Reel – Check.
5. Collective Friction – OFF.
6. Flight Controls – Then check center cyclic and pedals, collective full down.
7. Collective Friction – ON.
8. Throttle – Check, then idle cutoff.
9. Circuit Breakers – All IN.
10. Switches – All OFF.
11. Bleed Air Controls – OFF.
12. Systems Instruments – Check.
13. Flight Instruments – Check.
14. Fuel Valve – ON.
- (O) 15. Static Air Switch - STD
16. N1-N2-NR-TOT Switch – Turn to BATT and note needle movement. Turn to BUS and note tachometer and TOT needles are in “park” position. (see RFM)
- (O) 17. Magnetic Compass Switch – Check slave.

18. Ground Power Unit – As required.
19. BATT Switch – ON.
20. Indicator Status – Check status during power-on self-tests (see RFM).
- (O) 21. Attitude Indicator(s) – Erect.
22. Warning Lights – Check on.
23. Caution Panel – Test.
24. Check Temperature and Select Correct  $V_{NE}/CG$  Placard.
25. Clock – Checked and set.
- (O) 26. Digital Fuel Quantity – Check. Enter new fuel quantity if required.
27. Engine Out/Rotor RPM Audio – Test.
28. Throttle – Check closed.
29. Cyclic Trim – Check.
30. Anticollision Lights – ON.
- (N) 31. Position LTS Switch – ON as required.

## **STARTING ENGINE**

1. Exhaust Area – Clear.
2. Rotor Blades – Clear and untied.
3. Verify TOT.
4. Engine – Start.
  - a. Starter switch – Press and hold.



- b. TOT – Below 150°C.
  - c. Throttle – Open to idle stop after the  $N_1$  passes through 12-15%.
  - d. Monitor TOT.
  - e. Starter switch – Release at 58%  $N_1$ .
  - f. Engine oil pressure – Check.
  - g. Gas producer – Check 59-65%  $N_1$ .
  - h.  $N_2$  – Check stabilized.
5. Ground Power Unit – Disconnect.

---

## CAUTION

---

**Check that the ground power unit is disconnected prior to turning the Generator switch ON.**

6. MAIN GEN Switch – ON.
7. Avionics ON – AMP < 50 AMPS.

### ***ENGINE RUNUP***

1. Engine – Stabilize one minute.
2. Throttle – Full on. (see RFM)
3. GOV INCR/DECR Switch – Set to 98%  $N_2$ .
4. Engine and Transmission Indications – Check.

5. ENG ANTI-ICE – Check.
6. SCAV AIR – Check.
- (O) 7. DEFOG and HEAT – Check.
- (O) 8. PITOT HTR – Check.
- (O) 9. Avionics – Check and set.
10. Altimeter – Set.
- (O) 11. Heading Indicator(s) – Check.
- (O) 12. Doors – Secured.
13. Seat Belts and Shoulder Harnesses – Secured.
14. Flight Controls – Check.
15. Collective Friction – Set as desired.

### ***HOVER CHECK***

1. Flight Controls – Check.
2. Engine and Transmission Instruments – Check.
3. Flight Instruments – Check.
4. Engine Power – Check.

### ***BEFORE TAKEOFF***

1. N<sub>2</sub> - 103% – See RFM supplement for operations with floats installed.
2. Systems – Check.

3. Fuel – Check quantity.
- (O) 4. COM/NAV Radios – Set.
- (O) 5. Heading Cross Checked With Compass.
- (O) 6. Transponder – ON as appropriate.
7. Crew, Passengers and Unused Seats –  
Final check of restraints.

### ***BEFORE LANDING***

1. N<sub>2</sub> - 103%.
2. Systems – Check.
3. Fuel – Check quantity.
4. Crew and Passengers – Check.
5. Landing Lights – As required.

### ***AFTER LANDING***

1. Landing Lights – As required.
- (O) 2. Transponder – As required.

### ***ENGINE SHUTDOWN***

#### **NOTE**

**On the last flight of the day,  
perform a deceleration check  
(see RFM).**

1. Collective Pitch – Full down
2. Collective Friction – ON.
3. Throttle – Idle. Stabilize for two minutes.
- (O) 4. Avionics – OFF.
5. All Electrical Switches – OFF except BATT, POS LTS, STRB LTS, BCN LTS.

---

## CAUTION

---

**Main GEN switch must be OFF before closing throttle to shut engine down.**

6. Throttle – Closed.
7. TOT – Monitor.
8. Lights – OFF.
9. BATT Switch – OFF.

### ***BEFORE LEAVING HELICOPTER***

1. Walk Around Inspection – Complete.
2. Complete Aircraft Log Book Entries.
3. Secure Helicopter.

## **PASSENGER BRIEFING**

1. Entry and exit of aircraft
2. Seating
3. Seat Belts
4. Internal Communications
5. Security of Equipment
6. Smoking
7. Emergency Exits
8. Emergency Equipment
9. Emergency Landing/Ditching Procedures

**INTENTIONALLY LEFT BLANK**

# EMERGENCY PROCEDURES

## ENGINE

### ***IMMEDIATE ENGINE RELIGHT***

1. Enter Autorotation.
2. Engine Start Button – Depress and hold.

### **NOTE**

**The throttle does not have to be retarded to idle if the elapsed time between failure and attempted relight has not exceeded 5 seconds.**

### ***ENGINE RESTART – DURING FLIGHT***

1. Autorotative Glide – Establish.
2. Attempt Start – If altitude permits.
  - a. Throttle – Closed.
  - b. Starter Button – Depress.
  - c. Throttle – Idle ( $N_1$  15% or greater.)
  - d. TOT and  $N_1$  – Monitor.
  - e. Starter Button – Release at 58%  $N_1$ .
  - f. Throttle – Advance to full ON.
  - g. Powered Flight – Resume.
3. Land Immediately.

## ***ENGINE FAILURE – GENERAL***

1. Collective – Down.
2. Autorotational Glide – Establish. Use collective to maintain RPM within limits.
3. Flare and Land.
4. Fuel Valve Handle – OFF.
5. BATT Switch – OFF.

### **NOTE**

If time permits during the descent, the fuel valve and BATT switch turned OFF, and the N1-N2-NR-TOT switch should be turned to BATT prior to touchdown to reduce the possibility of fire.

## ***ENGINE OVERSPEED***

RPM can be controlled manually

1. Collective Pitch – Increase.
2. Throttle – Reduce to normal operating range.
3. Land – Perform a power on approach and landing.



If RPM cannot be controlled manually:

4. Throttle – Closed.
5. Collective Pitch – Down. Establish autorotational glide.
6. Land.
7. Fuel Valve – OFF.
8. BATT Switch – OFF.

### ***ENGINE UNDERSPEED***

If RPM does not come back:

1. Check throttle – Full ON.
2. Check GOV INCR/DECR switch.
3. Collective Pitch – Down. Establish autorotational glide.
4. Throttle – Closed.
5. Land.
6. Fuel Valve – OFF.
7. BATT Switch – OFF.

### ***ENGINE SURGES***

1. GOV INCR/DECR Switch – Increase for maximum RPM.
2. Throttle – Reduce to 101% N<sub>2</sub>.

3. Land Immediately – Perform a power on approach and landing without delay.

If engine surges cannot be controlled:

4. Throttle – Closed when over a safe landing area.
5. Collective Pitch – Down. Establish autorotational glide.
6. Land.
7. Fuel Valve – OFF.
8. BATT Switch – OFF.

## **ENGINE COMPRESSOR STALL**

1. Power – Reduce.
2. Engine Anti-ice – OFF.
3. Heater – OFF.
4. Defog – OFF.
5. SCAV Air – OFF. Unless in snow or ice.

If stall still persists

6. Land – As soon as practicable.
7. After landing, perform normal shutdown.

## ***ENGINE OIL – LOW PRESSURE/HIGH TEMPERATURE – ENG OIL PRESS CAUTION LIGHT ILLUMINATED***

Accomplish a power on approach and landing immediately. If terrain is not suitable for landing, flight may be continued to a favorable landing area; however, be prepared for a complete engine failure.

## ***ENGINE CHIP CAUTION LIGHT***

Accomplish a power on approach and landing immediately. If terrain is not suitable for landing, flight may be continued to a favorable landing area; however, be prepared for a complete engine failure.

## ***ENGINE INLET AIR CAUTION LIGHT***

Pull the engine Scav-Air control handle full on, reduce power, and accomplish a power on approach and landing as soon as practicable.

# ROTORS, TRANSMISSIONS, AND DRIVE SYSTEMS

## ***MAIN DRIVE SHAFT FAILURE***

1. Collective Pitch – Down. Establish autorotational glide.
2. Throttle – Close.
3. Land. Accomplish autorotational descent and landing.
4. Fuel Valve – OFF.
5. BATT Switch – OFF.

## ***MAIN XMSN CHIP OR TAIL CHIP CAUTION LIGHT ILLUMINATION***

Accomplish a power on approach and landing as soon as practicable.

## ***DRIVE BEARING HOT CAUTION LIGHT ILLUMINATION***

Accomplish a power on approach and landing immediately. If terrain is not suitable for landing, flight may be continued to a favorable landing area; however, be prepared for a partial power loss or drive system failure at any time.

## ***MAIN XSMN HOT CAUTION LIGHT ILLUMINATION***

Verify the temperature indication by referring to the main transmission temperature gauge. If the high temperature indication appears to be valid, perform a power on approach and landing immediately. If terrain is not suitable for landing, flight may be continued to a favorable landing area; however, be prepared for a partial power loss or drive system failure at any time (Refer to RFM).

## ***XSMN PRESS CAUTION LIGHT ILLUMINATION***

Land as soon as practical. Monitor transmission oil temperature. If MAIN XSMN HOT caution light illuminates, verify indication by referring to the transmission temperature gauge. If valid indication, perform a power on approach and landing immediately (Refer to RFM).

## FIRE

### ***ENGINE COMPARTMENT FIRE – FLIGHT***

1. Collective Pitch – Down. Enter autorotation.
2. Throttle – Idle.
3. Fire Warning Light – Note. If FIRE warning light extinguishes within 10-15 seconds, resume powered flight at a reduced power level and land as soon as practical.

If FIRE warning light is still illuminated:

4. Throttle – Close.
5. Land.
6. Fuel Valve – OFF.
7. BATT Switch – OFF.
8. Clear the Helicopter.

### ***HOT START – EMERGENCY SHUTDOWN***

1. Throttle – Close.
2. Starter Switch – Continue to press the starter switch until the TOT is in the normal operating range.
3. Fuel Valve – OFF.

## ***FUSELAGE FIRE ON THE GROUND***

1. Throttle – Close.
2. Fuel Valve – OFF.
3. BATT Switch – OFF.
4. Clear the Helicopter.

## ***FUSELAGE FIRE – FLIGHT***

1. Land Immediately – Perform a power-on approach and landing without delay.
2. Throttle – Close as soon as the helicopter is on the ground.
3. Fuel Valve – OFF.
4. BATT Switch – OFF.
5. Clear the Helicopter.

## ***ELECTRICAL FIRE – IN FLIGHT***

1. MAIN GEN Switch – OFF.
2. BATT Switch – OFF.
3. N1-N2-NR-TOT Switch – BATT.
4. Land Immediately – Perform a power-on approach and landing without delay.

5. Engine Shutdown – After landing complete as follows:
  - a. Throttle – Closed.
  - b. Fuel Valve – OFF.
  - c. Clear the Helicopter.

### ***ELECTRICAL FIRE IN FLIGHT – IMMEDIATE LANDING NOT FEASIBLE***

1. Complete steps 1 through 3 above.
2. Circuit breakers – Out.
3. Generator Switch – GEN. – Check for fire.
4. BATT Switch – BATT. – Check for fire.
5. Circuit Breakers – Check one at a time.

### ***SMOKE AND FUME ELIMINATION***

1. Vents – Open.
2. Defog, Heater, and Fresh Air Valves – ON.

### **NOTE**

**If smoke is coming from the defog, heater, or fresh air system, turn them off.**



## **FUEL SYSTEM**

### ***FUEL FILTER CAUTION LIGHT ILLUMINATION***

Perform a power on approach and landing as soon as practicable.

### ***LOW FUEL CAUTION LIGHT ILLUMINATION***

Note the time when the light illuminates and plan a landing prior to fuel exhaustion.

## ELECTRICAL SYSTEM

### ***BATTERY SHORTING, HIGH AMPERAGE READINGS (LEAD-ACID BATTERIES)***

1. MAIN GEN Switch – OFF.

Then, if electrical equipment stops operating and/or the voltmeter indicates very low voltage:

1. BATT Switch – OFF.
2. AVIONICS Switch – OFF.
3. MAIN GEN Switch – ON. Monitor ammeter.

Then, if electrical systems operate normally and the amperage is appropriate:

1. AVIONICS Switch – ON.
2. Land – As soon as practicable.

### ***BATTERY TEMP CAUTION LIGHT ILLUMINATED (NI-CAD BATTERIES ONLY)***

1. BATT Switch – OFF.
2. Land – As soon as practicable.

### ***BATTERY HOT WARNING LIGHT ILLUMINATED (NI-CAD BATTERIES ONLY)***

1. BATT Switch – OFF.
2. Land – Immediately.

## **GENERATOR MALFUNCTION – DC GEN CAUTION LIGHT ILLUMINATING**

1. GEN FIELD circuit breaker – IN.
2. MAIN GEN Switch – OFF – then ON.
3. MAIN GEN Switch – OFF – If the main generator does not come back on line.

## **MAIN BUS FAILURE**

1. N1-N2-NR-TOT Switch – BATT.

## DITCHING

### ***ENGINE POWER OFF***

1. Autorotation – Enter.
2. Doors – Unlatch.

### **NOTE**

**As collective reaches full up position and helicopter settles in the water, apply full lateral cyclic in the direction helicopter tends to roll.**

3. Land – Complete.

### **WARNING**

**Clear helicopter as quickly as possible.**

4. Passengers and Pilot – Exit helicopter when main rotor stops.

### ***ENGINE POWER ON***

1. Hover – Low altitude hover over water.
2. Doors – Unlatch.

3. Passengers – Exit.
4. Hover – Hover clear of passengers.
5. BATT and MAIN GEN Switches – OFF.

### NOTE

**As collective reaches full up position and helicopter settles in the water, apply full lateral cyclic in the direction helicopter tends to roll.**

6. Hovering Autorotation – Complete.

### WARNING

**Clear helicopter as quickly as possible.**

7. Pilot – Exit helicopter when main rotor stops.

## FLIGHT CONTROL MALFUNCTIONS

### ***CYCLIC CONTROL VIBRATION ABSORBER BEAM FAILURE***

1. Land – As soon as practicable. (Refer to RFM)

## ***CYCLIC TRIM FAILURE***

If trim stops operating when the switch is engaged, or the trim does not stop when the switch is released, or if the circuit breaker trips:

1. Stop using trim immediately and pull the TRIM circuit breaker. Leave the circuit breaker out for the remainder of the flight.

If it is determined that flight can be continued safely, without use of trim, flight may be continued to the next destination.

If there is a safety concern, land as soon as practical.

1. Reduction in longitudinal control:
  - a. Attempt a shallow approach where a run-on landing can be made.
2. Reduction in lateral control:
  - a. Plan landing to an area with ample room.
  - b. Perform an approach to a low hover
  - c. Once forward speed is reduced in a low hover, roll off the throttle and align the aircraft with the direction of motion using the pedals prior to touching down.
  - d. If maintaining the approach course is difficult, make a 360° turn to the left to line up on the final approach again.