



SERVICE DIRECTIVE BULLETIN

SERVICE DIRECTIVE BULLETIN NO. 0096

Revision 2
Page 1 of 11

DATE: April 2, 2019

1. SUBJECT: Main Rotor Push-Pull Rod Inspection
2. MODEL: F-28, F-28A, 280, F-28C, F-28C-2, F-28C-2R, 280C, F-28F, F-28F-R, 280F,
 and 280FX
3. EFFECTIVITY: All
4. BACKGROUND:

Preliminary results of an accident investigation indicate that the failure of a main rotor push-pull rod, P/N 28-16253-1, was caused by corrosion on the inside surface of the push-pull rod. This Service Directive Bulletin (SDB) requires a visual inspection of the main rotor push-pull rods, P/Ns 28-16253-1 and 28-16253-101, for internal corrosion.

Revision 2 of this SDB corrects paragraph number reference errors.

5. COMPLIANCE:

Within ten (10) hours time in service or at the next annual inspection, whichever occurs first, review the aircraft maintenance records to determine the date “new” main rotor push-pull rods were installed in the aircraft. If the installation date for “new” main rotor push-pull rods cannot be determined from the maintenance records, use the aircraft “DATE MFD.” found on the aircraft data plate.

For main rotor push-pull rods (P/N 28-16253-1 or -101) in service for more than twenty (20) years, inspect the push-pull rods in accordance with (IAW) paragraph 6 of this SDB within ten (10) hours time in service or at the next annual inspection, whichever occurs first.

For main rotor push-pull rods (P/N 28-16253-1 or -101) in service between ten (10) years and twenty (20) years, inspect the push-pull rods IAW with paragraph 6 of this SDB within fifty (50) hours time in service or at the next annual inspection, whichever occurs first.

For main rotor push-pull rods (28-16253-1 or -101) in service less than ten (10) years, inspect the push-pull rods IAW paragraph 6 of this SDB before the push-pull rods reach ten (10) years time in service.

6. PROCEDURE:

INSPECTION

NOTE: Perform all maintenance in accordance with the applicable Enstrom F-28/280 Series Maintenance Manual (MM).

NOTE: Index mark each dog leg and nut to its respective push-pull rod before disassembly.

6.1. Remove the main rotor push-pull rods from the aircraft.

6.2. Visually inspect the exterior of the push-pull rods for corrosion (rust) especially the lower fitting attachment area. Reject push-pull rods that have heavy corrosion on the exterior of the push-pull rods and/or corrosion around the rivets attaching the lower fitting to the push-pull rod.

6.3. Remove the lower fittings from the push-pull rods using the following procedure:

NOTE: Applying heat to the lower fitting area of the push-pull rod will help break down the adhesive/sealer between the lower fitting and the push-pull rod.

WARNING

Use protective gloves when handling heated parts.

CAUTION

Do not exceed 250 °F/121 °C when heating the push-pull rods.

6.3.1 Index mark the location of the lower fitting in the push-pull rod.

6.3.2 Carefully drill off the heads of the MS20470AD4 rivets.

6.3.3 Place the push-pull rod onto the support tool with the upper rivet tail in the relief hole (refer to Figure 3) and support the opposite end of the rod.

6.3.4 Using a suitable size punch, remove the upper rivet from the push-pull rod. Repeat the procedure for the middle and lower rivets.

6.3.5 Using both halves of the support tool, secure the push-pull rod in a vise.

April 2, 2019

- 6.3.6 Install two (2) large area washers (refer to paragraph 7) onto the lower fitting and secure with a nut.
- 6.3.7 Using a jaw type slide hammer, remove the lower fitting from the push-pull rod.
- 6.4 Remove the upper fittings from the push-pull rods using the following procedure:

NOTE: Applying heat to the upper fitting area of the push-pull rod will help break down the adhesive/sealer between the upper fitting and the push-pull rod.

WARNING

Use protective gloves when handling heated parts.

CAUTION

Do not exceed 250 °F/121 °C when heating the push-pull rods.

- 6.4.1 Push-Pull Rod, P/N 28-16253-1:
 - 6.4.1.1 Index mark the location of the upper fitting in the push-pull rod.
 - 6.4.1.2 Carefully drill off the heads of the MS2047AD4 rivets.
 - 6.4.1.3 Place the push-pull rod onto the support tool with the lower rivet tail in the relief hole and support the opposite end of the rod. (This is the same procedure used to remove the rivets from the lower fitting. Refer to Figure 3.)
 - 6.4.1.4 Using a suitable size punch, remove the lower rivet from the push-pull rod. Repeat the procedure for the upper rivet.
 - 6.4.1.5 Using both halves of the support tool, secure the push-pull rod in a vise.
 - 6.4.1.6 Using a suitable length of round rod, insert a rod into the upper end fitting and pull the fitting out of the push-pull rod.
- 6.4.2 Push-Pull Rod, P/N 28-16253-101:
 - 6.4.2.1 Index mark the location of the upper fitting in the push-pull rod.
 - 6.4.2.2 File the heads of the CR3213-4-02 rivets to remove the lock rings.
 - 6.4.2.3 Using a suitable size drill bit, drill off the rivet heads and punch the rivets out.

- 6.4.2.4 Using both halves of the support tool, secure the push-pull rod in a vise.
- 6.4.2.5 Using a suitable length of round rod, insert a rod into the upper end fitting and pull the fitting out of the push-pull rod.
- 6.5 Using a suitable light source, inspect the inside of the push-pull rods for corrosion (rust) especially in the lower fitting area. Reject any push-pull rod that has corrosion (rust) severe enough to cause pitting on the inside of the push-pull rod or the lower fitting. Reject any push-pull rod that has visible moisture on the inside.

REPAIR/ASSEMBLY

WARNING

Use appropriate protective equipment and have adequate ventilation when working with solvents and primer coatings.

- 6.6. Remove light corrosion from the exterior surface of the push-pull rods using the following procedure:

NOTE: Maintain the index marks on the push-pull rods during removal of external corrosion and cleaning.

- 6.6.1 Remove the corrosion using a suitable abrasive cloth or wire brush.
- 6.6.2 Clean the area with a suitable solvent.
- 6.6.3 Apply a protective coating of epoxy primer meeting specification MIL-P-23377 Type 1 Class 1 or MIL-PRF-23377 Type 1 Class C or other suitable primer.
- 6.7. Remove light corrosion from the interior surface of the push-pull rods or the lower fittings using a suitable abrasive cloth or wire brush.
- 6.8 Clean the inside of the push-pull rod with a suitable solvent and allow to dry.
- 6.9 Coat the inside of the push-pull rod with epoxy primer meeting specification MIL-P-23377 Type 1 Class 1 or MIL-PRF-23377 Type 1 Class C or other suitable primer. Remove the excess primer from the push-pull rod and remove the primer from the upper and lower fitting surfaces of the push-pull rod. Allow the primer to dry.
- 6.10 Install the upper fittings into the push-pull rods using the following procedure:
 - 6.10.1 Push-Pull Rod, P/N 28-16253-1:
 - 6.10.1.1 Install the upper fitting into the push-pull rod and align the index marks.

- 6.10.1.2 Insert MS20470AD4-17 rivets into the rivet holes and determine if the rivet holes have been oversized. If the rivet holes are not oversized, proceed to paragraph 6.10.1.3. If one or both of the rivet holes is oversized, line drill the oversized rivet hole using a #21 drill bit and insert a MS20470AD5-17 rivet. Repeat the procedure for the other rivet hole if required.
- 6.10.1.3 Remove the upper fitting from the push-pull rod and deburr the holes if required.
- 6.10.1.4 Apply a light coating of sealant meeting specification MIL-S-81733 Type I Class 1 Grade A or MIL-S-81733 Type II Class 1 Grade A to the upper fitting and the inside surface of the push-pull rod and install the fitting in the push-pull rod.
- 6.10.1.5 Apply a light coating of sealant meeting specification MIL-S-81733 Type I Class 1 Grade A or MIL-S-81733 Type II Class 1 Grade A to the MS20470AD4-17 or MS20470AD5-17 rivets and install the rivets.
- 6.10.2 Push-Pull Rod, P/N 28-16253-101:
- 6.10.2.1 Install the upper fitting into the push-pull rod and align the index marks.
- 6.10.2.2 Install size 4 clecos in one set of the rivet holes and drill the other rivet holes using a #27 drill bit and install size 4 clecos.
- 6.10.2.3 Remove the size 4 clecos from the first set of rivets holes and drill the rivet holes using a #27 drill bit.
- 6.10.2.4 Remove the upper fitting from the push-pull rod and remove any drill chips from inside the push-pull rod.
- 6.10.2.5 Apply a light coating of sealant meeting specification MIL-S-81733 Type I Class 1 Grade A or MIL-S-81733 Type II Class 1 Grade A to the upper fitting and the inside surface of the push-pull rod and install the fitting in the push-pull rod.
- 6.10.2.6 Apply a light coating of sealant meeting specification MIL-S-81733 Type I Class 1 Grade A or MIL-S-81733 Type II Class 1 Grade A to the CR3243-4-02 rivets and install the rivets.
- 6.11 Install the lower fittings into the push-pull rods using the following procedure:
- 6.11.1 Install the lower fitting into the push-pull rod and align the index marks.

April 2, 2019

- 6.11.2 Insert MS20470AD4-17 rivets into the rivet holes and determine if the rivet holes have been oversized. If the rivet holes are not oversized, proceed to paragraph 6.11.3. If one or more of the rivet holes is oversized, line drill the oversized rivet hole using a #21 drill bit and insert a MS20470AD5-17 rivet. Repeat the procedure for the other rivet holes if required.
- 6.11.3 Remove the lower fitting from the push-pull rod and deburr the holes if required.
- 6.11.4 Apply a light coating of sealant meeting specification MIL-S-81733 Type I Class 1 Grade A or MIL-S-81733 Type II Class 1 Grade A to the lower fitting and the inside surface of the push-pull rod and install the fitting in the push-pull rod.
- 6.11.5 Apply a light coating of sealant meeting specification MIL-S-81733 Type I Class 1 Grade A or MIL-S-81733 Type II Class 1 Grade A to the MS20470AD4-17 or MS20470AD5-17 rivets and install the rivets.
- 6.11.6 Remove the excess sealant from the push-pull rod.
- 6.12 Vibro-etch "SDB 0096" on the upper rod fitting as shown in Figure 4. Do not etch the top of the fitting.
- NOTE: When installing the dog legs onto the push-pull rods, follow the specific procedures in the applicable aircraft model maintenance manual, and smoothly torque the retention nuts to prevent twisting of the dog leg on the push-pull rod.**
- 6.13 Install the push-pull rods in the aircraft.
- 6.14 Reassemble the aircraft.
- 6.15 Perform a limited maintenance test flight and track the main rotor system as required.

7. PARTS:

Part Number	Description	Quantity
28-16253-105*	Push-Pull Rod Assembly	As required
28-16253-103**	Push-Pull Rod Assembly	As required
MS20470AD4-17	Rivet	As required
MS20470AD5-17	Rivet	As required
CR3243-4-02	Rivet	12 Ea. (Used with 28-16253-101)
AN320-8	Nut	As required
AN381-3-16	Cotter Pin	3 Ea.
AN381-2-8	Cotter Pin	11 Ea.
N/A	Large Area Washer, ½" X 1 ¾"	2 Ea.

* Push-Pull Rod Assembly, P/N 28-16253-105, replaces Push-Pull Rod Assembly, P/N 28-16253-1.

** Push-Pull Rod Assembly, P/N 28-16253-103, replaces Push-Pull Rod Assembly, P/N 28-16253-101.

NOTE: Enstrom has set up an exchange/replacement program to help reduce the maintenance down time resulting from compliance with this SDB. Contact Enstrom's Product Support Department for more information. Tel: 906-863-1200; Fax: 906-863-6821; email: customerservice@enstromhelicopter.com.

NOTE: Push-Pull Rod Assembly, P/N 28-16253-1, can be replaced by Push-Pull Rod Assembly, P/N 28-16253-101 or -103; however, the Main Rotor Pitch Change Bellcrank, P/N 28-14207-7 or -101 must be installed. Refer to Service Information Letter 0146 for more information.

8. CONSUMABLE MATERIALS:

Description	Specification	Source
Epoxy Primer	MIL-P-23377 Type 1 Class 1	PRC-Desoto, Randolph Products, Sherwin-Williams Company
Epoxy Primer	MIL-PRF-23377 Type 1 Class C	PRC-Desoto, Randolph Products, Sherwin-Williams Company
Sealant	MIL-PRF-81733 Type I Class 1 Grade A	PRC-DeSoto
Sealant	MIL-PRF-81733 Type II Class 1 Grade A	PRC-DeSoto, Advanced Chemistry & Technology, Inc.,
Solvent	MEK, Acetone, Toluene	Local Procurement

April 2, 2019

9. SPECIAL TOOLS:

Tool Number	Description
T-0045	Lower Swashplate Dogleg Puller
T-0054	Swashplate Dogleg Alignment Tool
N/A	Push-Pull Rod Support Tool (Refer to Figure 1)
N/A	Jaw Type Slide Hammer (Refer to Figure 2)

10. MAN-HOURS: 20 hours per inspection

11. WARRANTY: N/A

12. WEIGHT CHANGE: N/A

13. LOG BOOK ENTRY: Enter compliance with this SDB in the aircraft maintenance records.

14. REPETITIVE ACTIONS: N/A

April 2, 2019

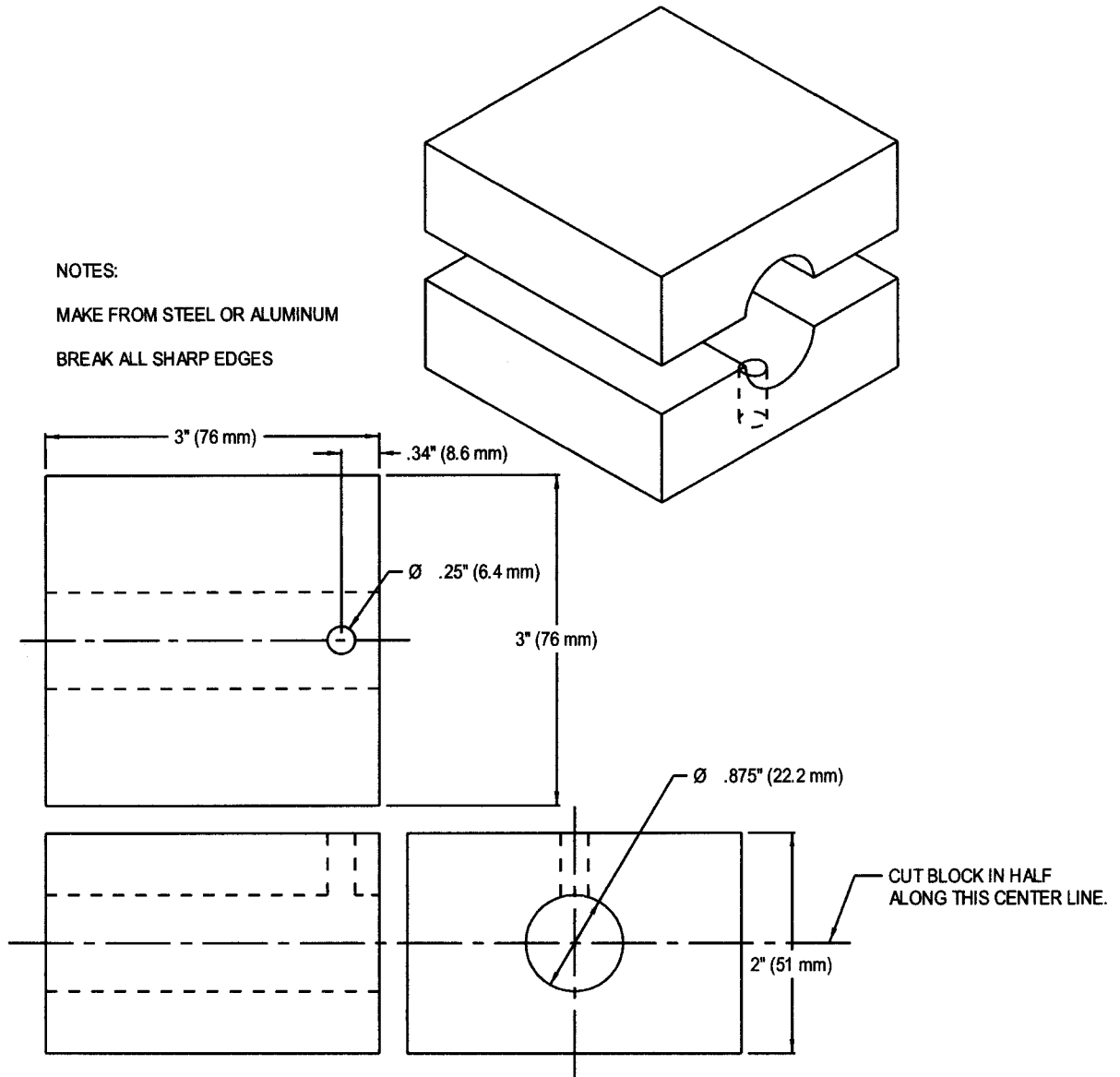

Figure 1. Support Tool



Figure 2. Jaw Type Slide Hammer

April 2, 2019

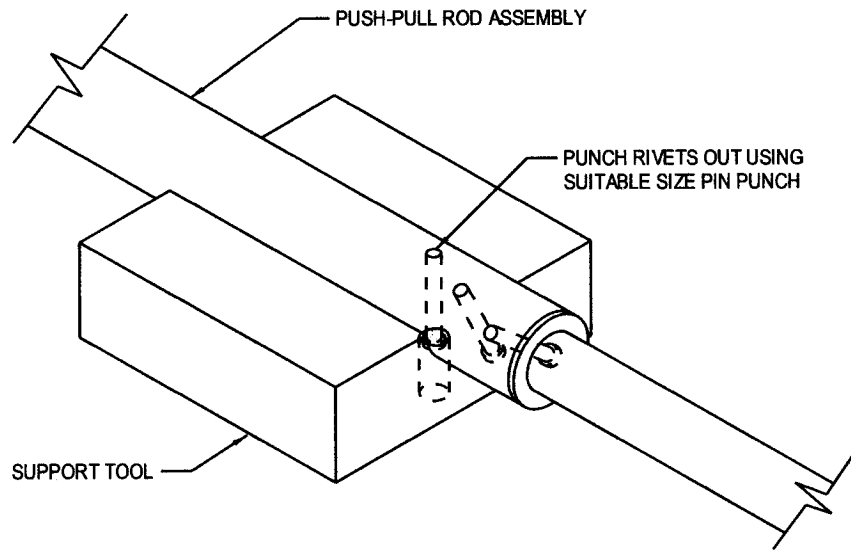

Figure 3. Rivet Removal

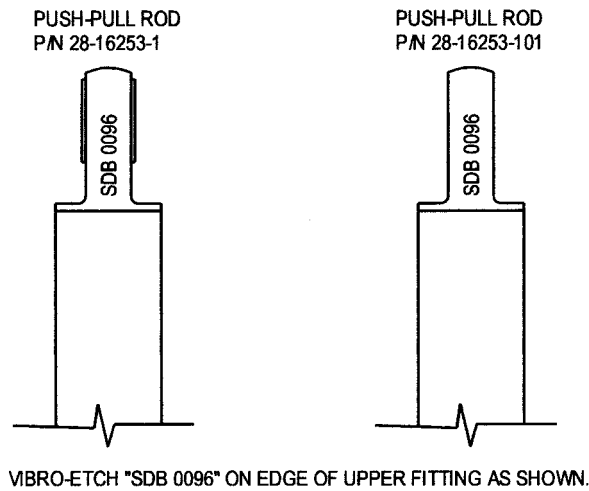

Figure 4. Push-Pull Rod Marking