

# THIS IS THE 280



Ownership of the 280 Helicopter will provide you with a smooth, distinctive, and comfortable mode of flight geared to the concept of modern transportation. For business or pleasure, the field of operations is practically unlimited, as point-to-point travel can be accomplished from either prepared or unprepared areas. The distinctive appearance of the 280 is symbolic of prestige and its high performance capabilities. Under the graceful lines of the 280 is a ruggedly constructed helicopter designed for easy servicing, minimum maintenance, dependability and economical operation.

Copyright 1976, The Enstrom Corporation, Menominee, Michigan, U.S.A.





## SECTION 1 – GENERAL

Cover Page – FAA Approval .....	FM-1-1
Log of Pages and Revisions .....	FM-1-2
EASA Log of Revisions .....	FM-1-2.2
Log of Supplements .....	FM-1-3

## SECTION 2 – OPERATING LIMITATIONS – FAA APPROVED

Power Plant Limitations .....	FM-2-1
Rotor – Flight Limitations – Power Off .....	FM-2-1
Instrument Markings .....	FM-2-1
Airspeed Limitations.....	FM-2-2
Altitude Limitations.....	FM-2-2
Weight Limitations.....	FM-2-2
Center of Gravity Limitations.....	FM-2-2
Type of Operation .....	FM-2-2
Placards.....	FM-2-3

## SECTION 3 – NORMAL PROCEDURES – FAA APPROVED

Normal Engine Starting Procedures.....	FM-3-1
Engine Starting Procedures, Hot Condition.....	FM-3-2
Rotor Engagement.....	FM-3-2
Engine Warm-up and Ground Check .....	FM-3-2
Flight Information .....	FM-3-3
Engine Cooling and Shutdown Procedure .....	FM-3-4

## SECTION 4 – EMERGENCY & MALFUNCTION PROCEDURES – FAA APPROVED

Engine Failure.....	FM-4-1
Lighting Failure .....	FM-4-1
Fire.....	FM-4-1
Fire on Ground.....	FM-4-1
Fire in Flight .....	FM-4-1
Tail Rotor (Anti-Torque) System Failure .....	FM-4-2
Tail Rotor Drive System Failure .....	FM-4-2
Tail Rotor Control System Failure .....	FM-4-3
Pitch Link Failure (One Tail Rotor Blade).....	FM-4-3
Failure of Left Pedal Controls.....	FM-4-3
Failure of Right Pedal Controls .....	FM-4-3
Landing in Water.....	FM-4-4
Ditching With Power.....	FM-4-4
Ditching Without Power.....	FM-4-4
Alternator Failure .....	FM-4-5

Main Rotor Gearbox .....	FM-4-5
Electrical Fuel Boost Pump .....	FM-4-5
Low Engine Oil Pressure .....	FM-4-5
Nickel – Cadmium Battery .....	FM-4-5
Abnormal Vibrations .....	FM-4-6
Lamiflex Bearing Failure .....	FM-4-7

## SECTION 5 – PERFORMANCE DATA – FAA APPROVED

Best Rate of Climb Speed .....	FM-5-1
Minimum Rate of Descent Speed .....	FM-5-1
V <sub>NE</sub> vs. Density Altitude Chart .....	FM-5-1
Airspeed Calibration .....	FM-5-2
Hover Ceiling in Ground Effect .....	FM-5-3
Height - Velocity Diagram (Operation at Sea Level) .....	FM-5-4
Height - Velocity Diagram (Operation at 700 ft.) .....	FM-5-5
Density Altitude Chart .....	FM-5-6
Rate of Climb Chart .....	FM-5-7

## SECTION 6 – 280 SUPPLEMENTS – FAA APPROVED

## SECTION 7 – AIRCRAFT AND SYSTEM DESCRIPTION

Interior Arrangement .....	FM-7-1
Air Induction System .....	FM-7-1
Power Plant .....	FM-7-1
Oil System .....	FM-7-1
Oil System Indicators – Oil Temperature and Pressure Gauges .....	FM-7-2
Engine Controls .....	FM-7-2
Throttle .....	FM-7-2
Mixture Control .....	FM-7-2
Magneto Switch .....	FM-7-2
Ignition Safety Switch .....	FM-7-2
Starter Button .....	FM-7-2
Master Switch .....	FM-7-2
Cabin Heat .....	FM-7-2
Clutch Engaging Lever .....	FM-7-2
Fuel System .....	FM-7-2
Auxiliary Fuel Pump Switch .....	FM-7-3
Fuel Quantity Indicator .....	FM-7-3
Fuel Flow – Fuel Pressure Indicator .....	FM-7-3
Transmission System .....	FM-7-3
Main Rotor Transmission Temperature Indicator .....	FM-7-3
Tail Rotor transmission .....	FM-7-4

Rotor System .....	FM-7-4
Main Rotor .....	FM-7-4
Tail Rotor .....	FM-7-4
Rotor Tachometer .....	FM-7-4
Flight Controls .....	FM-7-4
Cyclic Control .....	FM-7-4
Stabilizer .....	FM-7-4
Collective Pitch Control .....	FM-7-4
Directional Control Pedals .....	FM-7-5
Flight Instruments .....	FM-7-5
Airspeed Indicator .....	FM-7-5
Altimeter .....	FM-7-5
Compass .....	FM-7-5
Free Air Temperature Indicator .....	FM-7-5
Electrical Power Supply System .....	FM-7-5
Direct Current Power System .....	FM-7-5
Key to Instrument Panel .....	FM-7-6
Electrical Power Panel .....	FM-7-7
Lighting Equipment .....	FM-7-7
Position Lights .....	FM-7-7
Anti-Collision Lights .....	FM-7-7
Landing Lights .....	FM-7-7
Ground Handling Wheels .....	FM-7-7
Baggage Compartment .....	FM-7-8
Interior Views of Cabin .....	FM-7-8
Specifications .....	FM-7-9
Preflight Inspection .....	FM-7-10
Fuel Management .....	FM-7-10
Exterior Preflight Inspection .....	FM-7-10
Interior Preflight Inspection .....	FM-7-12
Exterior Inspection Illustration .....	FM-7-13

## SECTION 8 – WEIGHT AND BALANCE

Information .....	FM-8-1
Weight and Balance .....	FM-8-1
Tools and Equipment .....	FM-8-1
Detailed Procedure for Weighing Helicopter .....	FM-8-1
Loading Information .....	FM-8-5
Center of Gravity Envelopes – Lateral and Longitudinal .....	FM-8-6
Weight and Balance Report .....	Form F-166
Aircraft Actual Weight Report .....	Form F-167
Aircraft Weight and C.G. Calculation .....	Form F-168
Basic Weight and Balance Report .....	Form F-165
Equipment List .....	(No Number)

## SECTION 9 – OPERATIONAL INSTRUCTIONS

Introduction.....	FM-9-1
Solo Flight .....	FM-9-1
Taxiing .....	FM-9-1
Takeoff .....	FM-9-1
Normal Takeoff to Hover .....	FM-9-1
Normal Takeoff from Hover .....	FM-9-2
Maximum Power takeoff.....	FM-9-2
Maximum Power Takeoff from Confined Area .....	FM-9-2
Crosswind Takeoff.....	FM-9-3
Normal Approach for Landing.....	FM-9-3
Steep Approach.....	FM-9-3
Landing – Landing Site Evaluation .....	FM-9-4
Wind Direction and Velocity.....	FM-9-4
Normal Landing .....	FM-9-5
Crosswind Landing .....	FM-9-5
Flight Characteristics – Handling and Stability.....	FM-9-5
Maneuvering Flight .....	FM-9-6
Hovering Flight .....	FM-9-7
Student Training .....	FM-9-7
Noise Abatement.....	FM-9-7
Leaning with an EGT .....	FM-9-8
Cold Weather Operation.....	FM-9-8
Blade Tape .....	FM-9-9
Loss of Tail Rotor Effectiveness .....	FM-9-9

## SECTION 10 – DAY-TO-DAY CARE

Ground Handling .....	FM-10-1
Mooring .....	FM-10-1
Transporting .....	FM-10-1
Storage.....	FM-10-1
Hoisting .....	FM-10-1
Jacking .....	FM-10-2
Exterior Paint.....	FM-10-2
Windows and Doors .....	FM-10-2
Upholstery and Carpets.....	FM-10-2
Landing Gear Shock Struts .....	FM-10-2
Air Cleaner or Filter .....	FM-10-2
Lights.....	FM-10-3
Battery .....	FM-10-3
Dampers – Main Rotor .....	FM-10-3
Transmission – Main .....	FM-10-3
Transmission – Tail Rotor.....	FM-10-3
Lubrication.....	FM-10-3
Excessive Grease.....	FM-10-3

<b>Main Rotor and Tail Rotor Blades</b> .....	<b>FM-10-4</b>
<b>Fuel</b> .....	<b>FM-10-4</b>
<b>Oil</b> .....	<b>FM-10-4</b>
<b>Cooling System</b> .....	<b>FM-10-4</b>
<b>Required FAA Forms</b> .....	<b>FM-10-4</b>

This electronic document is not linked to a subscription for revision control or distribution. Refer to the Technical Publications Status link under the Technical Support Page of the Enstrom Helicopter website for the current revision level of the 280 Rotorcraft Flight Manual.



ENSTROM 280

ENSTROM MODEL 280  
HELICOPTER

Type Certificate No.	H1CE
Registration No.	
Approved by	
for Chief, Engineering and Manufacturing Branch Flight Standards Division Great Lakes Region Federal Aviation Agency	
September 13, 1974	

FAA Approval: September 13, 1974  
Revised: May 22, 1998

Report No. 28-AC-013

**ENSTROM 280**

**SECTION 1**

**LOG OF PAGES AND REVISIONS**

Rev. No.	Pages	Description	Date	F.A.A. Approved*
1	FM-5-3	HIGE Improved	6/17/75	<i>Charles E. Connel</i>
2	FM2-2 FM8-5 FM8-6	Revised lateral c.g. envelope	8/25/82	<i>John C. [Signature]</i>
3	FM-2-4 FM-3-2 FM-3-3 FM-3-4	Added placard and operational information	23 Nov 82	<i>Maschutt</i>
4	FM 1-1 FM 2-1 FM 2-3 FM 3-2 FM 3-4 FM 7-2	Revised Added engine Added placard Added info Added info	29 AUG 85	<i>Larry S. Houser</i>
5	FM2-1 FM3-3 FM7-11 FM9-9 FM10-4	Minor Revision Minor Revision Added Blade Tape Information "	17 Feb 89	<i>Pat Mae</i>
6	FM4-6	Added page	April 18 1985	<i>Pat Mae</i>

\* Approved for Manager  
Chicago Aircraft Certification Office  
Central Region  
Federal Aviation Administration



**NOTE:** All revisions are indicated by a black vertical line. |

FAA Approval: September 13, 1974

Revised: May 22, 1998

Report No. 28-AC-013

## LOG OF PAGES AND REVISIONS

Rev. No.	Pages	Description	Date	FAA Approved*
7	i-v  FM-1-1 FM-1-2  FM-1-1.2 FM-1-3  FM-4-4 FM-4-5 FM-4-6	Added and Revised Page Numbers  Added and Revised Page Numbers  FAA Approval  Revised Emergency Procedure and Moved Text	May 22/98	Joseph C. Miess
8	ii  FM-1-2.1  FM-4-7 FM-4-8	Revised  FAA Approval  Added Lamiflex Bearing Failure Emergency Procedures	Jul 9/12	 Joseph C. Miess
9	i, iii  FM-1-2.1 FM-1-2.2 FM-1-4  FM-7-10 FM-7-11 FM-7-12 FM-7-13 FM-7-14	Revised  FAA Approval EASA Update (Blank)  Added Fuel Check  (Blank)	MAR 28 2017	 ACE-117C

\* Approved for Manager  
Chicago Aircraft Certification Office  
Central Region  
Federal Aviation Administration

**NOTE:** All revisions are indicated by a black vertical line.

FAA Approval: March 28, 2017  
Revised: February 14, 2017

Report No. 28-AC-013

## EASA LOG OF REVISIONS

Rev. No.	Date	EASA Approved	FAA Approval on Behalf of EASA
1	Sep 28/03	Article 3, Commission Regulation (EU) 748/2012	N/A
2	Sep 28/03	Article 3, Commission Regulation (EU) 748/2012	N/A
3	Sep 28/03	Article 3, Commission Regulation (EU) 748/2012	N/A
4	Sep 28/03	Article 3, Commission Regulation (EU) 748/2012	N/A
5	Sep 28/03	Article 3, Commission Regulation (EU) 748/2012	N/A
6	Sep 28/03	Article 3, Commission Regulation (EU) 748/2012	N/A
7	Sep 28/03	Article 3, Commission Regulation (EU) 748/2012	N/A
8	Aug 17/15	FAA/EASA T.I.P.*	G. J. Michalik
9	Aug 16/17	FAA/EASA T.I.P.*	

\* Section 3.2 T.I.P.

**LOG OF SUPPLEMENTS**

Sup. No.	Pages	Description	Date	FAA Approved*

\* Approved for Manager  
Chicago Aircraft Certification Office  
Central Region  
Federal Aviation Administration

I

INTENTIONALLY LEFT BLANK

## ENSTROM 280

NOTE: Mandatory compliance with the data contained in this section is required by law.

### SECTION 2 - OPERATING LIMITATIONS

#### POWER PLANT LIMITATIONS

Engine	Lycoming Model H10-360-C1A or H10-360-C1B	
Fuel	100/130 minimum grade	
Oil Viscosity	Above 60°F	SAE 50
	30-90°F	SAE 40
	0-70°F	SAE 30
	Below 10°F	SAE 20
Horsepower	205 HP all operations at 2900 maximum	
Operating Engine RPM	2900 maximum	
	2750 minimum	
Engine Idling RPM	1400 minimum (clutch disengaged)	
Manifold Pressure	Full throttle, sea level engine	
Oil Temperature	245°F maximum	
Oil Pressure	60-90°PSI, normal operation	
	25 PSI, idling minimum	
	100 PSI, starting-warmup	
Transmission Oil Temp	220°F maximum	
Cylinder Head Temp	475°F maximum	

#### ROTOR - FLIGHT LIMITATIONS (POWER OFF)

Maximum	385 RPM
Minimum	313 RPM

#### INSTRUMENT MARKINGS

Rotor Tachometer	Red Line	385 RPM
	Red Line	313 RPM
	Green Arc	313-385 RPM
Engine Tachometer	Red Line	2750 RPM
	Red Line	2900 RPM
	Green Arc	2750-2900 RPM
Airspeed Indicator	Red Line	112 MPH
Oil Temperature	Red Line	245°F
	Green Arc	120° - 245°F
	Yellow Arc	60° - 120°F

## ENSTROM 280

Oil Pressure	Red Line	100 PSI
	Green Arc	60 - 100 PSI
	Yellow Arc	25 - 60 PSI
	Red Line	25 PSI
Cylinder Head Temp	Red Line	475°F
	Green Arc	200° - 475°F
Transmission Oil Temp	Red Line	220°F
	Green Arc	0° - 220°F

### AIRSPEED LIMITATIONS

Never exceed speed  $V_{NE}$ : 112 mph IAS at S.L.  
For variations with altitude see page FM-5-1.

### ALTITUDE LIMITATIONS

Maximum operating 10,000 feet pressure altitude  
Maximum for takeoff and landing 7,000 feet density altitude

### WEIGHT LIMITATIONS

Maximum approved weight 2,150 lb

### CENTER OF GRAVITY LIMITATIONS

Forward	2,150 lbs.	92.0 in. station
Rearward	2,150 lbs.	94.0 in. station
Rearward	1,930 lbs.	98.0 in. station

Lateral Offset Moment 2,150 lbs. -1,620, +3,700 in. lbs.  
Below 2,150 lbs. see page FM-8-6

This helicopter is to be loaded in accordance with Section 8, Loading Information.

NOTE: Longitudinal Station 0 (Datum) is located 100 inches forward centerline of main rotor hub.

Lateral Station 0 (Datum) is aircraft centerline, lateral moment arms are positive right, negative left (looking forward).

### TYPE OF OPERATION

The helicopter is approved for operation under DAY & NIGHT - VFR - NON-ICING CONDITIONS.

Night operation authorized under visual contact flight conditions.



## ENSTROM 280

Orientation must be maintained by ground light or adequate celestial illumination.

Instrument flight prohibited.

No acrobatic maneuvers permitted.

Crosswind and downwind: When hovering or landing, adequate flight control can be maintained in winds up to 20 MPH. Operation with doors removed is approved.

### PLACARDS

"THIS HELICOPTER MUST BE OPERATED IN COMPLIANCE WITH THE OPERATING LIMITATIONS SPECIFIED IN THE FAA APPROVED ROTORCRAFT FLIGHT MANUAL."

### AIR SPEED LIMITATIONS - MPH

#### Never Exceed Speeds - Miles per Hour IAS

Pressure Altitude	Outside Air Temperature - °F						
	-20	0	20	40	60	80	100
SL	112	112	112	112	112	104	98
2000	112	112	112	105	98	92	87
4000	112	106	99	92	87	83	80
6000	100	98	88	83	79	75	72
8000	89	84	79	75	71	68	
10000	80	75	71	68	65		
12000	72	68	65	62			

"NO SMOKING" (This placard not required when an approved ash tray is installed.)

"THIS HELICOPTER IS APPROVED FOR OPERATION UNDER DAY & NIGHT - VFR - NON-ICING CONDITIONS ONLY."

"60 LBS. MAX. THIS COMPARTMENT" (When baggage compartment is installed.)

"THIS HELICOPTER IS APPROVED FOR OPERATION UNDER DAY - VFR - NON-ICING CONDITIONS ONLY" (This placard not required when an approved night lighting kit is installed.)

"STOW FLAT ON FLOOR BEFORE FLIGHT" (This placard to be placed on clutch handle.)

## ENSTROM 280

"COLLECTIVE FRICTION TO BE USED FOR GROUND OPERATION ONLY"  
(This placard to be placed adjacent to the collective friction device.)

FOR NICKEL-CADMIUM BATTERY INSTALLATION ONLY:

### BATTERY TEMPERATURE ALERT

120°F - Monitor battery temperature (amber light).

130° F - Turn off alternator switch.

Reduce electrical load, turn alternator switch on if amber light goes out in flight.

150° F - Turn off master switch.

(RED ARC) - Land as soon as practical. Inspect battery per manufacturer's instructions before further flight.

Each 250 hour interval, perform functional tests per K.S. Avionics instructions.

ENSTROM 280

SECTION 3 - NORMAL PROCEDURES

280 NORMAL ENGINE STARTING PROCEDURE

1. Seat belts fastened and doors latched.
2. Fuel valve pushed in to turn on.
3. Collective full down and locked with the friction knob.
4. Heater as desired (in for OFF).
5. Cyclic stick cannon plugs secure.
6. Rotor clutch disengaged.

CAUTION: Although starting the helicopter with the rotor clutch engaged will not damage the rotor system, it will severely overload the starter motor.

7. Check compass full of fluid, no bubbles, and that it has a correction card.
8. Altimeter set to field elevation.
9. Radio(s) off.
10. All switches off.
11. Master switch and alternator on (alternator OFF if using an APU start). Ignition switch ON.
12. Throttle cracked open -- cracked open is 1/16".
13. Mixture full rich.
14. COLD ENGINE START - Fuel boost pump on until the fuel pressure gauge shows a rise, then boost pump off.
15. Mixture idle cut off; throttle closed, mags on BOTH; depress starter, when engine fires mixture full rich.
16. Fuel boost on (pump must be on at all times in flight).
17. Check engine oil pressure is off the zero line within 30 seconds.
18. Check amp meter gauge indicates a charge.
19. If APU start, disconnect APU cable. Then alternator switch on; check for a charge indication on the amp meter.
20. Idle engine at 1450 to 1500 rpm.
21. When oil pressure is 25 psi or above, clutch may be engaged.

CAUTION: On rare occasions the engine may backfire through the induction system during a start procedure. The backfire will not cause damage to the induction system but it could cause the induction hose between the air filter and the fuel injection servo unit to be disconnected due to the backfire. It is recommended that should a backfire occur during engine starting, a visual inspection be accomplished by the pilot or mechanic to assure that the hose is securely in place before takeoff.

## ENSTROM 280

### 280 ENGINE STARTING PROCEDURES, HOT CONDITION

1. Master switch ON.
2. Magneto switch OFF.
3. Throttle cracked.
4. Mixture control FULL RICH.
5. Turn on fuel boost pump 5 to 6 seconds.
6. Turn boost pump off.
7. Mixture control FULL LEAN.
8. Throttle - FULL OPEN.
9. Engage starter 5 to 6 seconds to clear engine.
10. Close throttle and crack slightly.
11. Magneto switch BOTH. Ignition switch on.
12. Engage starter until engine fires and advance mixture slowly.
13. Fuel boost ON. (Pump must be on at all times in flight.)

NOTE: It is important to follow this procedure on hot starts so that the prolonged fuel flow in the lines will eliminate the vapor locks and cool the lines for a proper start.

### 280 ROTOR ENGAGEMENT

1. Check collective pitch full down and friction on.  
CAUTION: Collective friction to be used for ground operation only.
2. Tail rotor pedal neutral position.
3. Center cyclic stick with trim switch.
4. Check aircraft vicinity clear of personnel and equipment.
5. Check engine idle set at 1450 to 1500 rpm, then leave throttle fixed in this position; don't add more throttle during engagement.
6. Slowly and smoothly engage clutch handle at 1450 to 1500 rpm, allowing the engine rpm to bleed no lower than 1200 rpm. When the rotor rpm reaches 100 rpm, fully engage clutch.  
NOTE: Clutch disengaged warning light will go out when the clutch is fully engaged.
7. Place clutch handle in stowed position.

### 280 ENGINE WARMUP AND GROUND CHECK

1. Advance throttle to 1800 rpm and wait for cylinder head temperature to reach low green or 200°F.

## ENSTROM 280

2. After reaching 200° F cylinder head temperature, slowly advance throttle to 2300 rpm until oil temperature reads low green or 120°F.
3. Increase engine rpm to 2900 rpm and check for rpm drop on right and left magnetos. A 100-rpm drop is permissible on either magneto as long as there is no engine roughness when operating on either right or left magneto.
4. Gently close throttle to split tachometer needles to check proper operation of over-running clutch.
5. Check following before take-off:
  - a. Check all instruments for proper indication.
  - b. Seat belts and doors latched.
  - c. Fuel ON.
  - d. Fuel boost ON. (Pump must be on at all times in flight.)
  - e. Mixture FULL RICH.
  - f. Fuel pressure warning - green indication.
  - g. Clutch warning light - push to test - red light goes out when released.
  - h. Release collective friction.

NOTE: Keep hand on collective and maintain down position when friction lock is disengaged.

- i. Set throttle friction as desired.

### FLIGHT INFORMATION

#### Takeoff

1. Follow normal helicopter takeoff procedure at 2900 rpm. (See height-velocity curve, pages FM 5-4 and 5-5.)
2. Best rate of climb speed is approximately 58 mph IAS.

#### Cruise

Do not exceed  $V_{NE}$  as shown on placard and  $V_{NE}$  versus altitude curve, page FM-5-1.

#### Descent

CAUTION: Exercise care during descent to avoid exceeding  $V_{NE}$ .

#### Running Landing

1. Maximum recommended ground contact speed is 35 mph. Reduce speed on rough surfaces.
2. After ground contact the ship must have zero forward motion before collective pitch is lowered fully.

FAA Approval: Sept. 13, 1974  
Revised: **FEB 17 1989**

Report No. 28-AC-013

## ENSTROM 280

### Prelanding Checks

1. RPM - 2900.
2. Fuel quantity.
3. Instruments.
4. Mixture full rich.
5. Boost pump - check on.

### 280 ENGINE COOLING AND SHUT-DOWN PROCEDURE

1. Collective pitch full down and friction on.
2. Throttle closed.
3. Fuel boost pump off.
4. Clutch disengaged, engine at idle only.

CAUTION: Clutch disengagement without throttle at full idle will result in engine overspeed.

NOTE: Clutch disengagement is signaled by a red warning light on the instrument console.

5. Cyclic trim centered.
6. Idle engine at 1800 rpm for 2 minutes or until cylinder head temperature cools to 300°F.
7. Radios off.
8. Lights off.
9. Throttle closed.
10. Mixture idle cut off.
11. When engine stops turning, magnetos off.
12. All switches off.
13. Master switch off.
14. Fuel valve closed (out).
15. Set collective one-half way up in its travel to unload lamiflex bearings.
16. Tie down main rotor and tail rotor if wind speed is expected to go over 30 mph.

## SECTION 4 - EMERGENCY PROCEDURES

### ENGINE FAILURE

1. Enter normal autorotation and stabilize at 58 MPH. (Minimum rate of descent.)  
Maximum glide distance in autorotation is attained at 80 mph and 313 rotor rpm. (Reduce collective to build RPM prior to touchdown).
2. At about 75 feet above ground, apply aft cyclic to reduce forward speed.
3. When about 20-25 feet above surface, begin to level helicopter and apply collective pitch as necessary to cushion a level landing.

### LIGHTING FAILURE

1. Landing can be made in case of landing light failure by illumination from navigation lights. In case of a forward landing light failure, the taxi light will provide sufficient illumination to land.
2. Instrument lighting is provided by eyebrow lights, internal lights and maplight. While satisfactory landings have been demonstrated without instrument illumination, a supplemental light source (flashlight) is recommended.

### FIRE

Fires may have several sources of origin. Generally they may be classified as engine compartment or cabin compartment, fuel or oil supported, or electrical.

### FIRE ON GROUND

1. Shut off engine and all switches.
2. Shut off fuel valve.
3. Determine source of fire and use fire extinguisher to extinguish any flames.

**NOTE: Do not restart or fly aircraft until cause of fire is investigated and corrected.**

### FIRE IN FLIGHT

If the presence of odor and/or smoke is detected, proceed as follows:

1. Check instruments for correct reading.
2. Shut off master and alternator switches.
3. Unlatch doors and let them trail open.
4. If smoke and odor persist, proceed to suitable area and land aircraft.
5. If inspection of aircraft indicates presence of flames,

shut off engine and fuel valve and extinguish flames with fire extinguisher.

**NOTE:**

**If flames were present, do not attempt to start or fly aircraft until the cause of the fire has been investigated and corrected.**

Severe leakage of oil onto the exhaust system may cause considerable smoke to enter the cabin. In such case aircraft should not be flown until cause of leakage is investigated and corrected.

**TAIL ROTOR [Anti-Torque] SYSTEM FAILURE**

There are two major possibilities for failure of the tail rotor (anti-torque) system and subsequent loss of directional control as follows:

1. Failure of any portion of tail rotor drive system that causes stoppage or physical loss of the tail rotor blades.
2. Failure of any portion of the mechanisms that cause pitch change of the tail rotor blades.

Upon loss of directional control, the pilot must immediately determine the type of malfunction that has occurred (No. 1 or 2 above) and select the proper emergency procedure.

**TAIL ROTOR DRIVE SYSTEM FAILURE**

**During hovering flight** (aircraft will rotate rapidly to the right with full left rudder):

1. Cut throttle full off immediately (aircraft will slow down or stop its rotation).
2. Complete autorotational landing.

**During cruising flight** (aircraft will rotate to the right with full left pedal):

1. Power full off immediately, enter autorotation.
2. Complete autorotation to nearest suitable area.

**NOTE:**

**If no suitable area is available within autorotative distance, pilot should proceed as follows after having established stabilized autorotation with at least 60 MPH airspeed.**

1. Increase collective pitch and power gradually (maintaining 60 to 80 MPH airspeed) until yaw to the right reaches approximately 45 degrees.
2. Continue flight in this fashion using cyclic stick for



## ENSTROM 280

directional control until suitable autorotational landing site is reached.

3. When 200 ft. altitude or more over suitable area re-establish full autorotation and land.

### **TAIL ROTOR CONTROL SYSTEM FAILURE**

#### **NOTE:**

**Loss of control may be caused by failure of left pedal controls, right pedal controls or failure of pitch link to an individual tail rotor blade. On the Enstrom tail rotor, it is normal (if uncontrolled or unattended) for the blades to assume a nearly neutral pitch condition. Upon loss of ability to fully control tail rotor during cruising flight, proceed as follow:**

#### **PITCH LINK FAILURE (One tail rotor blade)**

**Aircraft will yaw to the right initially and will subsequently need an abnormal amount of left pedal to maintain straight and level flight since only one blade is providing anti-torque thrust.**

1. Fly at low cruise power to suitable landing area and make normal power approach.
2. Complete a slow run on landing at low power setting.

#### **FAILURE OF LEFT PEDAL CONTROLS**

**Aircraft will yaw to the right. Amount of yaw will depend on airspeed and amount of power being used.**

1. Remove feet from both rudder pedals.
2. Reduce power to low cruise setting (18 to 19" Hg. manifold pressure will create zero yaw at 60 MPH).
3. Fly to suitable area and complete normal shallow power on approach at 60 MPH.
4. Manipulate power and collective pitch so that aircraft touches down straight ahead at an airspeed of 0 - 10 MPH. Reduce power and collective cautiously as skids contact surface.

#### **NOTE:**

**At low airspeed, power settings UNDER approximately 18"Hg. will cause yaw to the left. Power settings OVER 18"Hg. will cause yaw to the right. Do not attempt to abort the emergency landing after airspeed is slowed below 40 MPH.**

#### **FAILURE OF RIGHT PEDAL CONTROLS**

**Rudder control will be normal at power settings over 18" MP. Power settings under 18" MP will produce yaw to the left. Proceed as follows:**

1. Fly to suitable landing area at a power setting of at least 18" MP.

## ENSTROM 280

2. Complete normal shallow power on approach at 60 MPH (do not autorotate).
3. Manipulate power and collective pitch so that aircraft touches down straight ahead at an airspeed of 0-10 MPH. Reduce power and collective pitch cautiously as skids contact surface.

### NOTE:

Application of power to over 18" MP will make aircraft more controllable. Therefore, landing attempt may be aborted and new approach initiated as many times as necessary.

### LANDING IN WATER (Ditching)

If ditching is unavoidable without other recourse, proceed as follows:

#### DITCHING WITH POWER

1. Descend to low hovering altitude over water.
2. Unlatch both doors and exit passengers.
3. Hover aircraft clear of all personnel in water.
4. Turn off master and alternator switches.
5. Complete hovering autorotation into water.
6. As collective pitch reaches full up and aircraft settles in water, apply full lateral cyclic in direction aircraft tends to roll.
7. After rotor strikes water and stops, climb out and clear aircraft.

#### DITCHING WITHOUT POWER

1. Turn off master and alternator switches.
2. Unlatch both doors.
3. Complete normal autorotation to land in water at zero airspeed.
4. As collective pitch reaches full up and aircraft settles in water, apply full lateral cyclic in direction aircraft tends to roll.
5. After rotor strikes water and stops, exit all occupants and clear aircraft.

#### ALTERNATOR FAILURE

A malfunction of the alternator will be indicated by zero charge rate or constant discharge on the ammeter. To put the alternator back on line, proceed as follows:

**NOTE:** Use the following procedure if the alternator excite circuit breaker (ALT EXC or ALTNTR EXC) is not installed.

1. Alternator circuit breaker in.
2. Cycle the MASTER and ALTERNATOR switches.
3. If the alternator is not restored or goes off line again, turn off the alternator switch and all nonessential electrical equipment. Land as soon as practicable.

## ENSTROM 280

**NOTE: Use the following procedure if the alternator excite circuit breaker (ALT EXC or ALTNR EXC) is installed.**

1. Alternator circuit breaker in.
2. Alternator excite circuit breaker in.
3. Cycle the ALTERNATOR switch.
4. If the alternator is not restored or goes off line again, turn off the alternator switch and all nonessential electrical equipment. Land as soon as practicable

### MAIN ROTOR GEARBOX

If, in normal flight, the main rotor gearbox red line temperature is exceeded, the aircraft should be landed at the next suitable landing site.

### ELECTRIC FUEL BOOST PUMP

Failure of the fuel boost pump will be evidenced by illumination of the red low boost pressure warning light. In the event of a fuel boost pump failure, the helicopter engine will continue to operate in a normal manner as long as the engine driven fuel pump continues to function properly.

If the helicopter experiences a fuel boost pump failure, terminate the flight at the earliest practical time and have the malfunction corrected prior to next flight.

**CAUTION:** If flight is continued after the fuel boost pump failure and the engine-driven fuel pump malfunctions, the engine will stop due to fuel starvation. Gravity fuel feed is insufficient to supply fuel to the engine.

### LOW ENGINE OIL PRESSURE

If low oil pressure is accompanied by normal oil temperature, there is a possibility the oil pressure gauge or relief valve is malfunctioning. This is not necessarily cause for an immediate precautionary landing. However, a landing at the nearest airport-heliport would be advisable to inspect the source of trouble.

If a total loss of oil pressure is accompanied by a rise in oil temperature, there is good reason to suspect an engine failure is imminent. Reduce engine power immediately and select a suitable forced landing field.

### NICKEL - CADMIUM BATTERY

If an increase in temperature is shown on the panel indicator (120° F), proceed as follows:

1. 120° F - Monitor battery temperature (amber light).

## ENSTROM 280

2. 130° F - Turn off alternator switch, reduce electrical load, and turn the alternator switch on if amber light goes out in flight.
3. 150° F - Turn off master switch (red arc). Land as soon as practical. Inspect ni-cad battery per manufactures's instructions before further flight.

### ABNORMAL VIBRATIONS

Vibrations in this helicopter can usually be classified as either low frequency or high frequency. Low frequency vibrations are generally caused by the main rotor system while the high frequency vibrations usually originate from the engine, drive system, or tail rotor. Any abnormal vibrations are an indication that something is not correct and should be referred to a mechanic before further flight. If a vibration suddenly appears during a flight, it is an indication that something has suddenly changed. The helicopter should be landed as soon as practical and inspected to find the cause of the vibrations. After the cause of the vibration has been identified, the pilot and the mechanic can determine whether the helicopter can be safely flown or should be repaired on the spot. An abnormal vibration is reason to get the aircraft down as soon as possible, but the pilot must also use caution and select the safest possible landing site, working around wires, people and other obstructions.

## LAMIFLEX BEARING FAILURE

A lamiflex bearing failure will cause a rough ride. Initially, this may be only a minor distraction, but in some cases, it can progress quickly to the point where the bearing physically comes apart. In this case, control of one blade will be stiff, the main rotor will be severely out of balance, and aircraft control may be in jeopardy. The following are indications of a lamiflex bearing failure as it progresses.

1. A significant worsening of the ride quality from one flight to the next or from one day to the next for no apparent reason.
2. The aircraft cannot be trimmed at a hover or runs out of trim at maximum forward flight speed when previously there was no problem.
3. The collective suddenly ratchets when moved up and down when previously it had been smooth or the collective suddenly feels heavy.
4. The cyclic suddenly wobbles or moves in a circular motion when previously it had been smooth.
5. The cyclic suddenly starts "chucking," (moving sharply in a left rear to right forward direction in about a 3/4" amplitude with a very crisp motion) especially at high power or high airspeed.

**WARNING:** This last indication where the cyclic starts sharply moving may be followed within a few minutes by a total failure of the bearing.

### **Emergency Procedures – Impending Lamiflex Bearing Failure**

The following are the procedures to be used in dealing with lamiflex failures. Refer to the preceding paragraph for the description of the failure symptoms.

1. Moderate – Slight worsening in ride or not able to trim:
  - a. **LAND** – As soon as practicable. Have all three bearings inspected before the next flight.
2. Serious – Ride continues to get worse or the cyclic or collective start showing symptoms:
  - a. **LAND** – Immediately. Have all three bearings inspected before further flight.

### **Emergency Procedures – Total Lamiflex Bearing Failure**

The following are the procedures to be used in dealing with total lamiflex bearing failure.

1. **Maintain control of the aircraft.**
2. **Collective – Lower slowly.** Commence an 800-900 ft/min descent.

**WARNING: Do NOT autorotate. Aircraft control at the termination of an autorotation may be questionable with a totally failed lamiflex.**

3. **Airspeed – Reduce** to 50-60 MPH.
4. **Rotor RPM – Reduce** to minimum power on RPM.
5. **Maneuvering – Minimize.**
6. **Land** – Perform a running landing. Touch down at or above Effective Translational Lift (ETL), approximately 20 knots if terrain permits.

**WARNING: It may not be possible to control the aircraft in a hover.**

8. **Shutdown – Complete.**

**ENSTROM 280**

**SECTION 5 - PERFORMANCE DATA**

Best rate of climb speed is 58 M.P.H. I.A.S.  
Minimum rate of descent speed is 58 M.P.H. I.A.S.

**Vnever exceed VS. DENSITY ALTITUDE**

(Vne demonstrated at 2750 engine rpm)

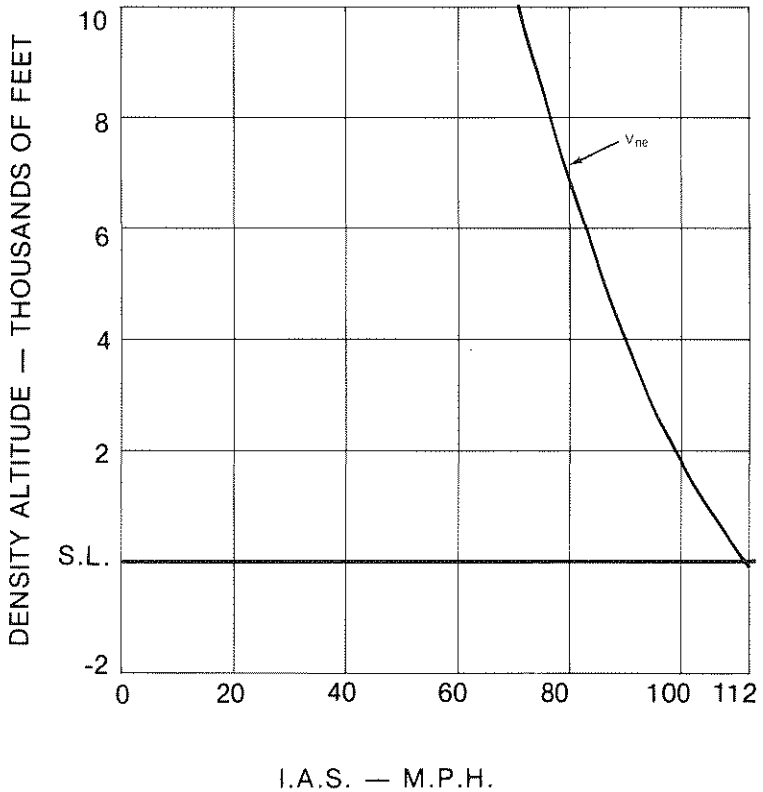

# ENSTROM 280

## AIRSPEED CALIBRATION

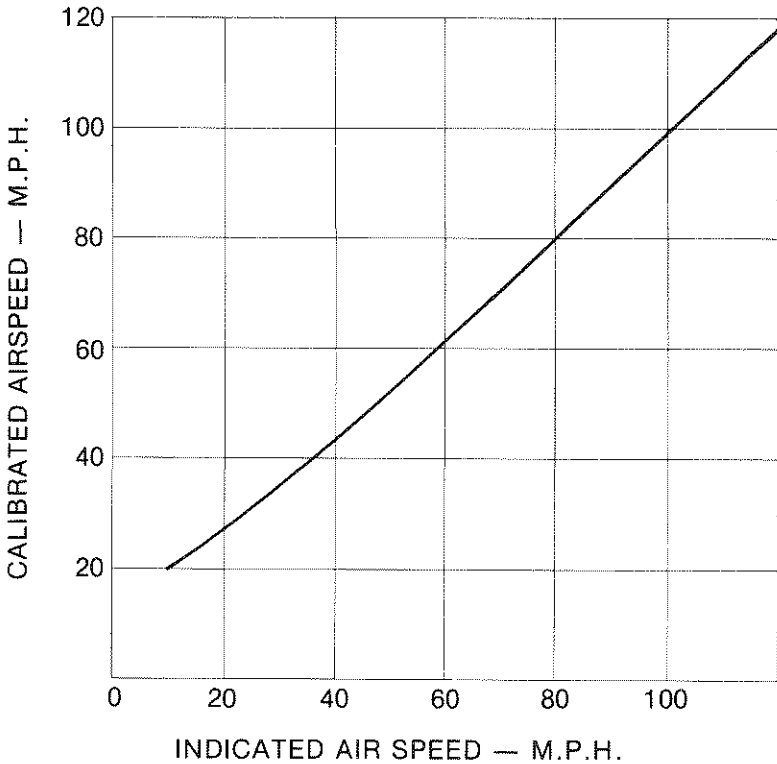

**NOTE: Indicated speeds below 20 MPH are not reliable.**



### ENSTROM 280

## HOVER CEILING IN GROUND EFFECT

3½ foot skid height  
(2900 RPM)

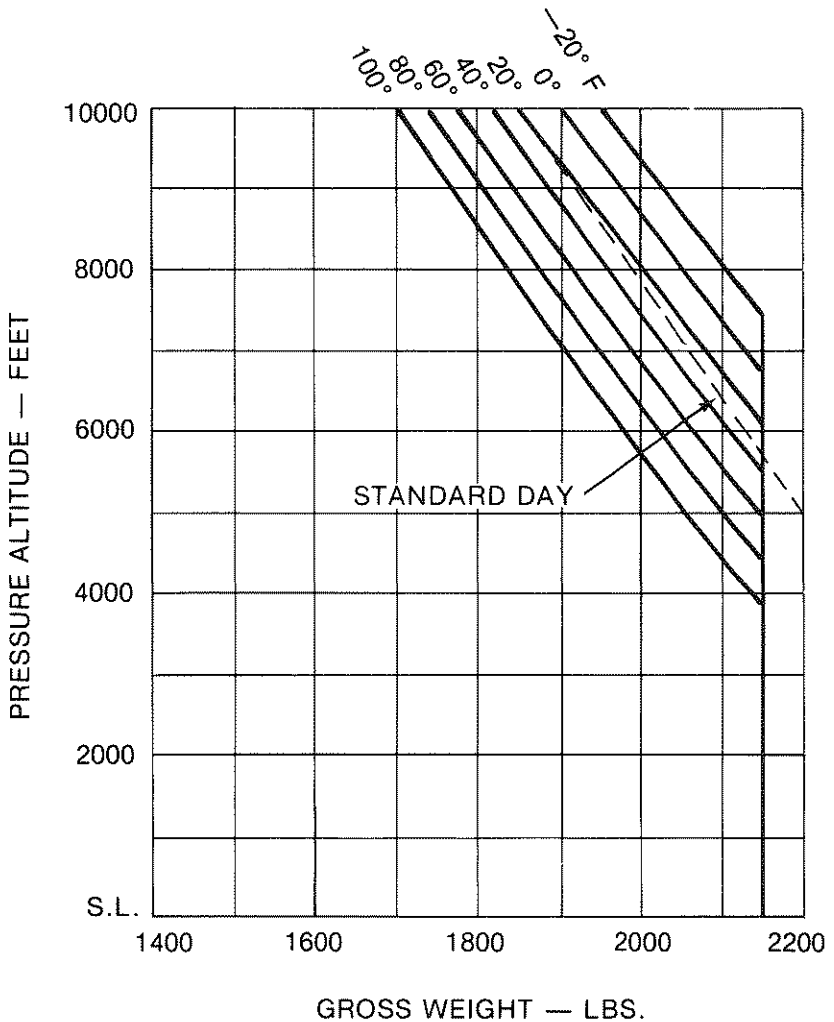

# ENSTROM 280

## HEIGHT—VELOCITY DIAGRAM

For Operation at Sea Level (Tests conducted on prepared surfaces)

### AVOID OPERATION IN SHADED AREAS

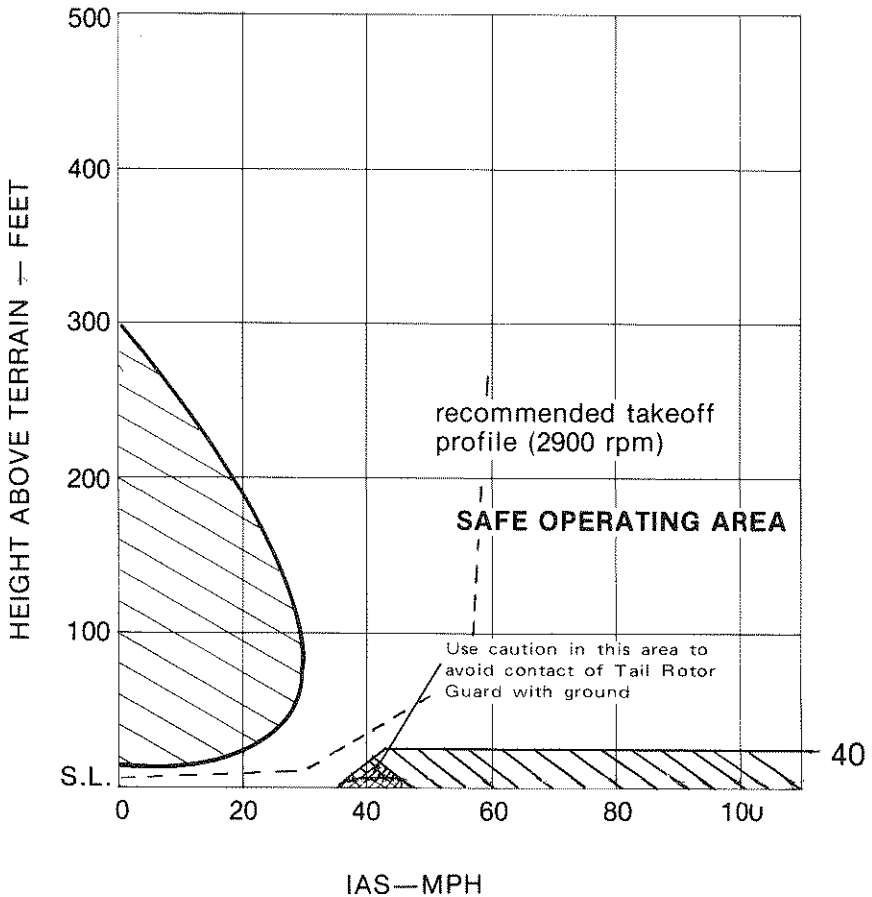

**ENSTROM 280**

# HEIGHT — VELOCITY DIAGRAM

For Operation at 7,000 Ft. Density Altitude  
(Tests conducted on prepared surfaces)

## AVOID OPERATION IN SHADED AREAS

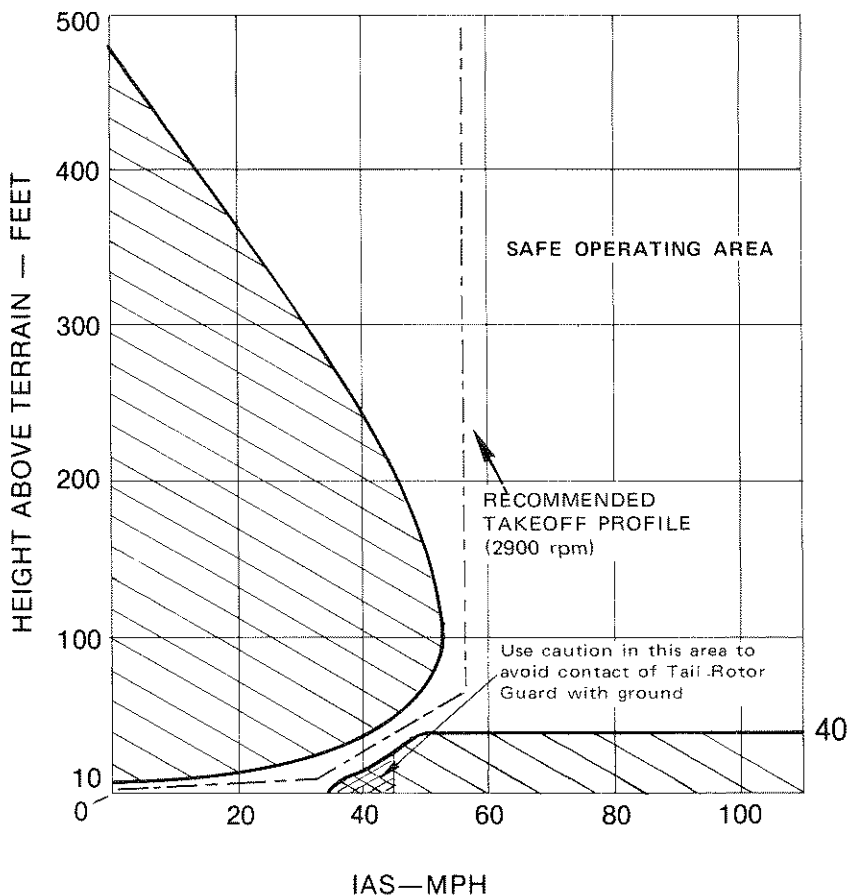

Weight applicability of H-V Diagram is based on hover capability at 3.5 feet skid height. (Reference FM-5-3)

**ENSTROM 280**

# DENSITY ALTITUDE CHART

SET ALTIMETER TO 29.92 IN. HG.  
WHEN READING PRESSURE ALTITUDE

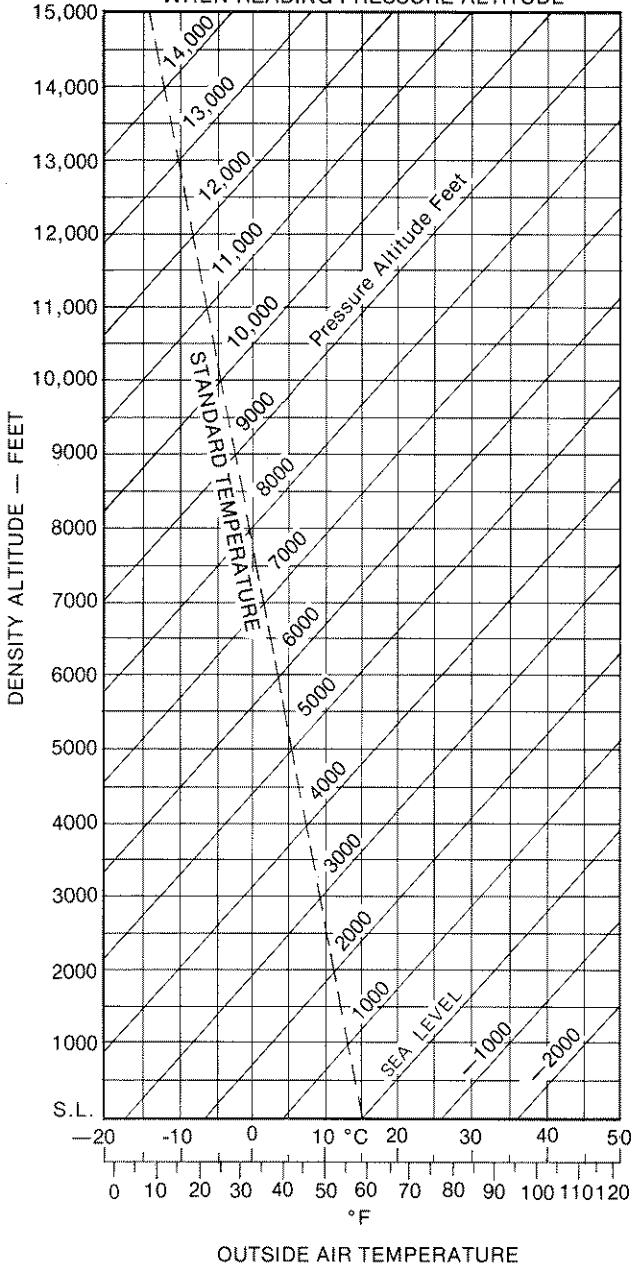

# RATE OF CLIMB/DENSITY ALTITUDE

2150 LBS. GROSS WEIGHT

58 mph I.A.S.

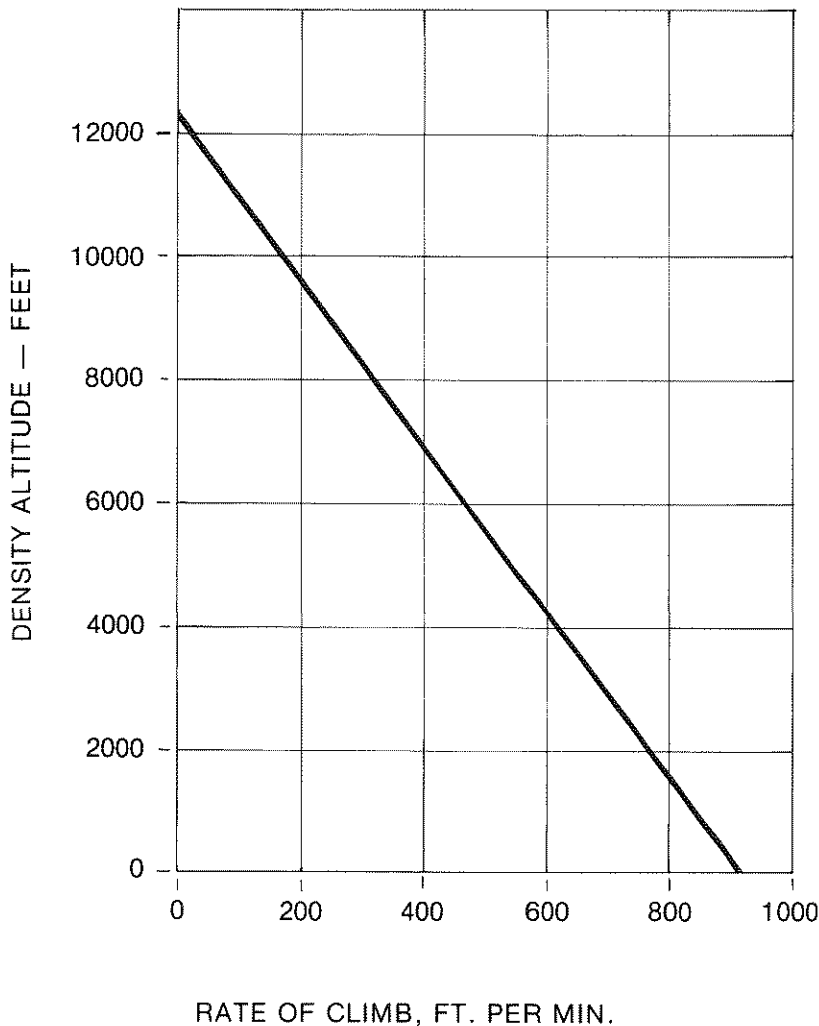

This electronic document is not linked to a subscription for revision control or distribution. Refer to the Technical Publications Status link under the Technical Support Page of the Enstrom Helicopter website for the current revision level of the 280 Rotorcraft Flight Manual.



## ENSTROM 280

### SECTION 7 - ENSTROM 280 DESCRIPTION

One of the first steps in obtaining the utmost performance, service, and flying enjoyment from your 280, is to familiarize yourself with its equipment, systems, and controls.

The Enstrom 280 Helicopter is designed for high performance, mechanical simplicity, and maximum versatility. By virtue of component longevity and minimum maintenance requirements, the 280 enjoys the lowest operating cost of any helicopter. The rugged, patented rotor head, combined with the (51 lbs. each) rotor blades, gives unheard of stability and excellent autorotational characteristics.

#### INTERIOR ARRANGEMENT

The cabin interior is a full, three-place, side-by-side seating arrangement with a spacious 58" width for maximum pilot and passenger comfort and safety. The instrument panel is on the vertical plane for more natural scanning and is conveniently located for dual pilot viewing. Excellent visibility is offered through the tinted Plexiglas wrap-around windshield and doors with overhead and lower deck windows. Extra-width, swing-open doors close securely with simple-to-operate safety lock handles. The helicopter can be flown with either left, right, or both doors off.

#### AIR INDUCTION SYSTEM

The air induction system consists of a filtered non-ram air intake located within the engine compartment. It incorporates a spring-loaded, automatic alternate air source.

#### POWER PLANT

A Lycoming H10-360-C1A 205 HP four cylinder opposed engine is used in this Helicopter. The engine is delivered with platinum spark plugs.

**NOTE: It is recommended that the appropriate Lycoming Operator's Manual be consulted prior to any adjustment or repair to the engine.**

#### OIL SYSTEM

The Lycoming engine employs a wet sump lubrication system. It has a capacity of 8 quarts. A bayonet-type oil quantity gauge with graduated markings is part of the oil tank filler cap and is accessible through the left fuel drain access door. Engine oil cooling is accomplished by an oil cooler with thermostatic valves and by-pass provisions. It

## ENSTROM 280

is located on the right-hand side of the engine compartment.

**OIL SYSTEM INDICATORS - OIL TEMPERATURE AND PRESSURE GAUGES.** Standard type gauges are provided for both the engine oil temperature and oil pressure indicators. Both gauges are marked to provide visual engine operating limitations and are located on the instrument panel.

### ENGINE CONTROLS

**THROTTLE.** A twist-grip type throttle is located on the collective pitch control stick for direct control of engine power. It is manually connected to the fuel servo-throttle valve on the engine.

**MIXTURE CONTROL.** A vernier mixture control knob is provided on the left side of the console. It is pushed in during all flight operations. Shutting off the engine is accomplished by placing the mixture control in the "Idle Cutoff" position.

**MAGNETO SWITCH.** The magneto switch is a key-operated switch located on the left side of the switch circuit breaker panel. For starting, place the switch in the "BOTH" position.

**IGNITION SAFETY SWITCH.** This switch closes the circuit to the starter button on the collective control.

**STARTER BUTTON.** The starter button is located on the end of the collective control. Push to engage.

**MASTER SWITCH.** The master switch is located on the left side of the switch circuit breaker panel. It is a single-throw, two-position switch.

**CABIN HEAT.** The cabin heat control is located at the left-hand side of the pilot's seat on the forward face of the seat structure. By moving the control in or out, the operator regulates the amount of cabin heat through two output louvers located on the seat structure just above the lower deck windows.

**CLUTCH ENGAGING LEVER.** The clutch engagement lever is located at the right side of the pilot's seat on the forward face of the seat structure. The clutch lever is provided as a means of engaging and disengaging the rotor drive system. The rotor drive system is engaged by pulling the clutch lever upward and rearward until the lever hits the stop and the warning light goes out. The handle can then be stowed by lifting it straight up and pivoting it down to the floor. When it is in the stowed position, the handle should lie flat on the floor. If it does not lie flat on the floor in the stowed position, the clutch rigging should be checked as described in Section 8 of the Maintenance Manual. The clutch lever must be stowed whenever the rotor drive system is engaged.

**FUEL SYSTEM.** The system consists of two interconnected 20 US gallon each fuel tanks, which feed simultaneously to the engine.



The tanks are located on the left and right side of the aircraft over the engine compartment. The tanks have a total fuel capacity of 40 U.S. gallons, with a total of 2 gallons unuseable fuel, one gallon unuseable fuel in each tank. Each fuel tank is gravity fed to a central distributing line which connects to the electric boost pump and engine driven pump. The fuel control valve is an off-on type and is located on the firewall next to the pilot's left shoulder. Each tank has an individual drain valve in the bottom. There is also a main gasolator filter located aft of the firewall in the engine compartment. The control is on the right-hand side of the engine compartment and extends beyond the side panel.

**Auxiliary Fuel Pump Switch.** The fuel boost pump switch and fuel pressure warning lights are located on the switch circuit breaker panel. The green warning light will stay illuminated as long as the fuel boost pump is operational. The red light will illuminate at any time the fuel boost pump is shut off or fails to function properly.

**Fuel Quantity Indicator.** The fuel quantity gauge continuously indicates the total quantity of fuel. It is hooked up through a simple type liquidometer float located in the right-hand fuel tank. A translucent strip on each tank provides a direct, visual indication of fuel level.

**Fuel Flow-Fuel Pressure Indicator.** The fuel pressure provides pounds per hour and pressure readings of the fuel as delivered to the flow divider. The indicator is marked for normal operating range from 0 to 115 pounds per hour and 0—6 and 12 psi index lines.

## TRANSMISSION SYSTEM

The main transmission unit provides an 8.787 reduction ratio between the engine and the main rotor. The transmission incorporates a free-wheeling unit in the upper pulley assembly which is mounted on the pinion input shaft. The free-wheeling unit provides a disconnect from the engine in the event of a power failure and permits the main and tail rotors to rotate in order to accomplish safe autorotation landings. Six pints of S.A.E. 90 wt. E.P. gear oil are used in the transmission. The main rotor transmission has a sight gauge which is located on the aft right-hand side and is visible through an opening in the baggage compartment or the right access panel.

**Main Rotor Transmission Temperature Indicator.** A main rotor transmission gauge is located on the instrument

panel and is redlined at 220° F.

**Tail Rotor Transmission.** The tail rotor transmission, mounted at the aft end of the tail cone, supports and drives the tail rotor. The tail rotor transmission is equipped with a self-contained lubricant supply and level gauge at the rear of the housing and magnetic plug can be removed to inspect for metal particles. Its capacity is 5 ounces of S.A.E. 10 wt. non-detergent motor oil.

## ROTOR SYSTEM

**Main Rotor.** The main rotor is a three-blade, fully articulated system. The fully articulated system in the 280 Helicopter provides smooth control responses in all modes of flight; and due to the kinetic energy stored in the heavy rotor blades, allows for easy-to-perform, safe autorotation landings in the event of power failure. The rotor assembly consists of three all-metal bonded blades, upper and lower rotor hub plates, universal blocks, blade grip assemblies, and lead lag hydraulic dampers.

**Tail Rotor.** The tail anti-torque rotor counteracts the torque of the main rotor and functions to maintain or change the helicopter heading. The tail rotor is a two-bladed, teetering, delta-hinge type assembly.

**Rotor Tachometer.** The rotor RPM indicator is part of a dual-purpose tachometer which also reads engine RPM.

## FLIGHT CONTROLS

**Cyclic Control.** The Cyclic control stick is similar in appearance to the control stick of a fixed-wing aircraft. The direction of stick movement results in a change of the plane of rotation of the main rotor and will produce a corresponding directional movement of the helicopter through the longitudinal and lateral modes of flight. The stick grip incorporates a trigger-type switch used for radio transmissions and intercom. A trim switch is also located on the cyclic stick grip to control the longitudinal and lateral trim motion.

**Stabilizer.** An all-metal, fixed-position stabilizer adjusted to a  $-6^\circ$  is installed on the tail cone assembly for longitudinal trim and vertical upper and lower stabilizer are installed for increased yaw stability.

**Collective Pitch Control.** The collective pitch control lever is located to the left of the pilot's position and controls the vertical mode of flight. A rotating, grip-type throttle is located at the end of the collective control.

**Directional Control Pedals.** The directional control pedals are located in the cabin forward of the pilot and/or co-pilot. When moved, these adjustable pedals change the pitch of the tail rotor blades and thereby provide the method of changing directional heading.

## FLIGHT INSTRUMENTS

The standard flight instruments which are installed in the 280 as basic equipment comply with the requirements under visual flight rules for day or night operation. The panel arrangement provides ease of visual observance and includes space provisions for installation of additional instruments to meet individual requirements.

**Airspeed Indicator.** The single-scale airspeed indicator is calibrated in MPH and provides an indicated airspeed reading during forward flight. The pitot tube, which provides air pressure source, is located below the cabin nose section. Static air pressure for instrument operation is derived from two static vents located on either side of the tail cone assembly. The openings in the pitot tube and static vent ports must be maintained obstruction-free and clean at all times for proper instrument operation.

**Altimeter.** The altimeter is a sensitive type that provides distance-height readings from 0 to 25,000 feet. The long hand in a single complete sweep of the dial totals 1,000 feet, and the short hand totals the thousands of feet altitude. The instrument is vented to the same static port vents as the airspeed indicator.

**Compass.** A standard aircraft quality magnetic compass is mounted on the center windshield support within easy sight of pilot or co-pilot. It is to be used in conjunction with a compass correction card located adjacent to the instrument.

**Free Air Temperature Indicator.** The free air temperature indicator is a direct reading, bi-metallic instrument with a stainless steel probe. This instrument provides ambient temperature information which, when utilized, will assist in determining performance capabilities of the helicopter at the existing climatic condition. The indicator is located in the top of the cabin.

## ELECTRICAL POWER SUPPLY SYSTEM

**Direct Current Power System.** The basic power supply system is a 12-volt direct current system, with a negative ground to the helicopter structure. A belt-drive 70 amp alternator is located on the aft part of the engine. One 12

## ENSTROM 280

volt battery is located in the right-hand side of the pilot's compartment and serves as a stand-by power source supplying power to the system when the alternator is inoperative.

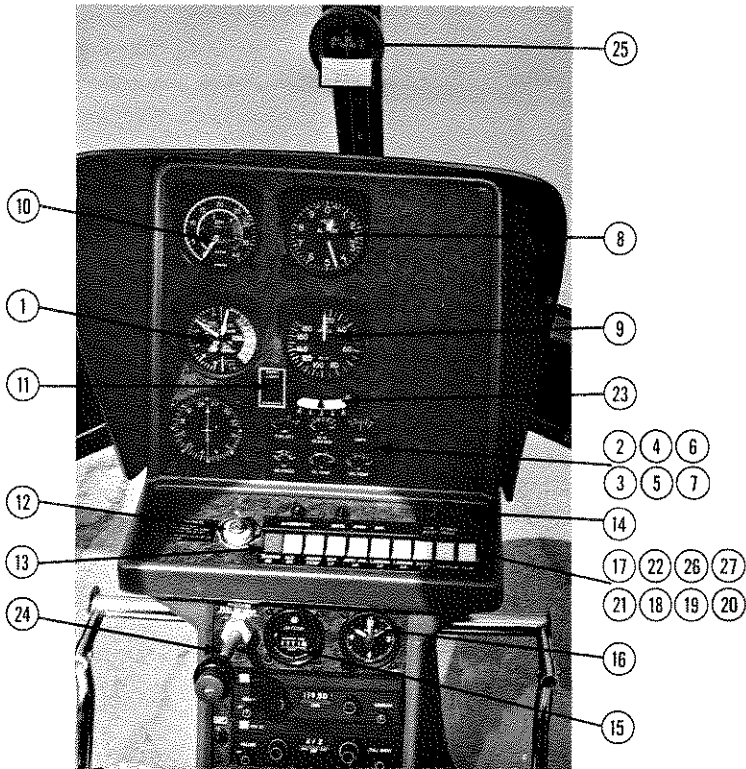

### 280 INSTRUMENT PANEL

- |                                                   |                                 |
|---------------------------------------------------|---------------------------------|
| 1. Manifold pressure/Fuel Flow                    | 15. Engine Hour meter           |
| 2. Fuel Quantity                                  | 16. Clock                       |
| 3. Oil Pressure                                   | 17. Instrument Lights           |
| 4. Main Rotor Gear Box                            | 18. Navigation Lights           |
| 5. Oil Temperature                                | 19. Anti—Collision Lights       |
| 6. Ammeter                                        | 20. Landing Light               |
| 7. Cylinder Temperature                           | 21. Alternator Switch           |
| 8. Altimeter                                      | 22. Panel Light Circuit Breaker |
| 9. Airspeed                                       | 23. Bank Indicator              |
| 10. Rotor/Engine Tachometer                       | 24. Mixture Control             |
| 11. Panel Light Dimmer Switch                     | 25. Compass                     |
| 12. Magneto Switch                                | 26. Ignition Safety Switch      |
| 13. Master Switch and Circuit Breaker             | 27. Trim Motor Switch           |
| 14. Fuel Pressure Indicator and Boost Pump Switch |                                 |

**Electrical Power Panel.** The following switches/combination circuit breakers are located on the switch circuit breaker panel mounted on the instrument console within easy reach of pilot or co-pilot: magneto key switch, master switch, alternator switch and alternator circuit breaker, boost pump switch, navigation position lights switch, anti-collision strobe light switch, landing light switches, panel light switch, starter switch, and trim motor switch.

## **LIGHTING EQUIPMENT**

The basic helicopter is equipped with the required lights necessary for VFR night operation plus additional lighting equipment for utility and convenience purposes. The electrical panel on the right-hand side of the instrument console contains the protective circuit breakers and control panels for the lighting equipment.

**Position Lights.** One position light is located on each horizontal stabilizer tip and one light is located aft of and below the tail rotor gearbox.

**Anti-Collision Lights.** The anti-collision lights have a strobe flashing action that provides for adequate identification of the helicopter. They are operated by the anti-collision switch located on the panel.

**Landing Lights.** The landing lights are of the permanent extend type, one is mounted on the nose and the other on the underside of the aircraft and set in the desired angle for the best forward and down illumination. The switches for operation of the landing lights are located on the instrument panel in the electrical console section. The light on the underside of the aircraft is primarily designed to provide illumination while hovering.

## **GROUND HANDLING WHEELS**

Each landing gear skid tube has a manually operated over-centering device to lower the wheels or retract them for flight. The ground handling wheels should be retracted and the helicopter allowed to rest on the skids when engine run-up is being performed or when helicopter is parked.



## ENSTROM 280

### BAGGAGE COMPARTMENT

The compartment for storage of baggage is provided in the area aft of the engine compartment. Access is through a single door located on the right-hand side which has a lock for external locking. The capacity of the compartment is approximately 10 cu. ft. and has an allowable loading capacity of 60 lbs. at Station 135.

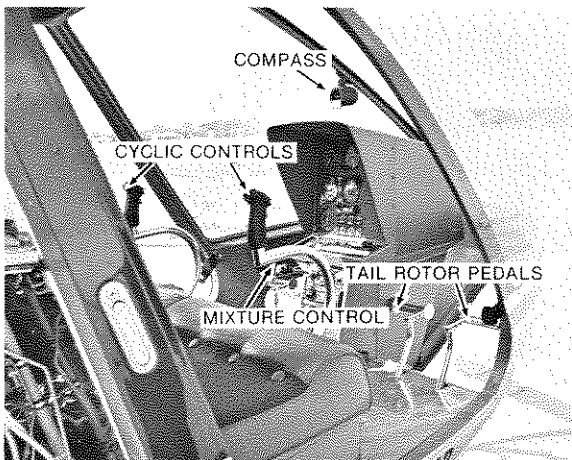

## SPECIFICATIONS

### Power Plant

Type	Lycoming
Designation	HIO-360-C1A
Cylinders	7
Normal Power	205 HP
Normal RPM	2900 RPM
Specific fuel consumption	.5 lbs. hp/hr
Weight	322 lbs.
Oil	8 qts. @ 15 lbs.

### Performance

Maximum speed (V ne)	112 M.P.H. I.A.S.
Best rate of climb	58 M.P.H. I.A.S.
Normal fuel capacity	40 U.S. gal. at 240 lbs.
Rate of climb at sea level	950 FPM
Hovering ceiling – IGE ft.	5600

### Operating RPM's

Engine	2750-2900
Tail Rotor	2365 (at 2900 engine RPM)
Main Rotor	330 (at 2900 engine RPM)
Main Rotor Autorotation Range	313-385

### Ratios

Lower to upper pulley	1:1.226
Main Rotor Gear Box	1:7.154
Tail Rotor Gear Box	1:1
Engine to main rotor	8.787

### Dimensions

Width (overall)	28'2"
Rotor diameter	32'
Height (overall)	9'
Length (overall)	27'8"
Cabin width at seat	58"
Tread-Landing Gear	7'4"

### Rotor System

Number of blades, main rotor	3
Chord-main rotor blade	9.5"
Disk area, main rotor	804 sq. ft.
Main rotor RPM	330

Tail rotor diameter	4.67'
Number of blades, tail rotor	2
Chord, tail rotor blade	3.375"

### Weight

Designed gross weight	2150 lbs.
Empty weight	1450 lbs.
Useful load	700 lbs.
C. G. travel	92" to 98"

## PREFLIGHT INSPECTION

After familiarizing yourself with the equipment of your 280, the primary concern will be its operation.

This checklist is designed to be used as a reference guide while performing the preflight inspection. Detailed information is found in the Handbook of Maintenance Instructions. Thoroughly familiarize yourself with this Manual before utilizing this checklist. Prior to starting the complete preflight inspection, check the following items in the cockpit: master switch OFF, magneto switch OFF, all other switches OFF, fuel valve ON.

### Fuel Management

1. Left fuel tank drain – Drain sample into jar. Verify the fuel grade, check the cleanliness, and check that fuel is free of water.

**WARNING: Sample the left and right fuel tank sumps before checking the fuel filter.**

**NOTE: Aircraft should be level or slightly nose down. Rock the aircraft by moving the tail up and down to displace any water or contaminants to the tank sumps. If water is found, rock the aircraft and re-sample. Check the other tank. Repeat until no water is found. Then check the fuel filter.**

2. Right fuel tank drain – Drain sample into jar. Verify the fuel grade, check the cleanliness, and check that fuel is free of water.
3. Fuel filter – Secure and drain fuel sample into jar. Verify the fuel grade, check the cleanliness, and check that fuel is free of water.



## Exterior

### **CAUTION: Remove all covers and locking devices.**

1. Check left hand door for security.
2. Check windshield for cracks.
3. Check pitot tube for obstructions.
4. Check landing lights for operation and security.
5. Check induction intake scoop for obstructions.
6. Check right hand shock strut – piston extension should be 3/4" to 1-3/4" from red line – struts clean.
7. Check right hand landing gear for security. (ground handling wheels secured)
8. Check right hand door for security.
9. Check right hand engine compartment.
10. Check air intake scoop for obstructions.
11. Check right hand fuel tank – FULL – 100/130 octane – cap secured.
12. Check main gear box oil level.
13. Check baggage door – locked.
14. Check right hand static port – opening unobstructed.
15. Check tail cone for general condition.
16. Check tail rotor drive shaft for security.
17. Check stabilizers for security.
18. Check navigation and strobe lights for operation and security.
19. Check tail rotor pitch links for binding or looseness. Check tail rotor blade for security and leading edge for nicks, bonding separation and general security.
20. Check tail rotor guard for damage and security. Also, check tail rotor gear box for oil quantity.
21. Check left hand static port – opening unobstructed.
22. Check main rotor blades for nicks, bonding separation or looseness. If blade tape is installed, inspect tape for holes, bubbles, blisters, separations, or lifting.

23. Check main rotor pitch links for binding or looseness.
24. Check cyclic and collective walking beams for security.
25. Check blade dampers for proper security and oil level.
26. Check left hand fuel tank – FULL – 100/130 octane – cap secured.
27. Check engine oil – 6 quarts minimum, 8 quarts maximum.
28. Check fuel system for leaks.
29. Check exhaust manifold for cracks and looseness.
30. Check engine for oil leaks.
31. Check drive belt system.
32. Check left hand shock struts – piston extension should be 3/4" to 1-3/4" from red line – struts clean and tires properly inflated.
33. Check left hand landing gear for security. (ground handling wheels secure)

### **Interior**

1. Check and adjust tail rotor pedals.
2. Check seat belts fastened or stowed.
3. Doors latched.
4. Set collective full down and friction on.
5. Check clutch disengaged.
6. Check throttle CLOSED.
7. Check mixture IDLE CUT OFF.
8. Check fuel valve ON.
9. Check magneto switch OFF.
10. Radio switches OFF.
11. Set master switch ON.
12. Check fuel quantity.
13. Check fuel pressure warning light (press to test).
14. Check trim motors for operation.
15. Check controls for freedom of operation.
16. Set altimeter.

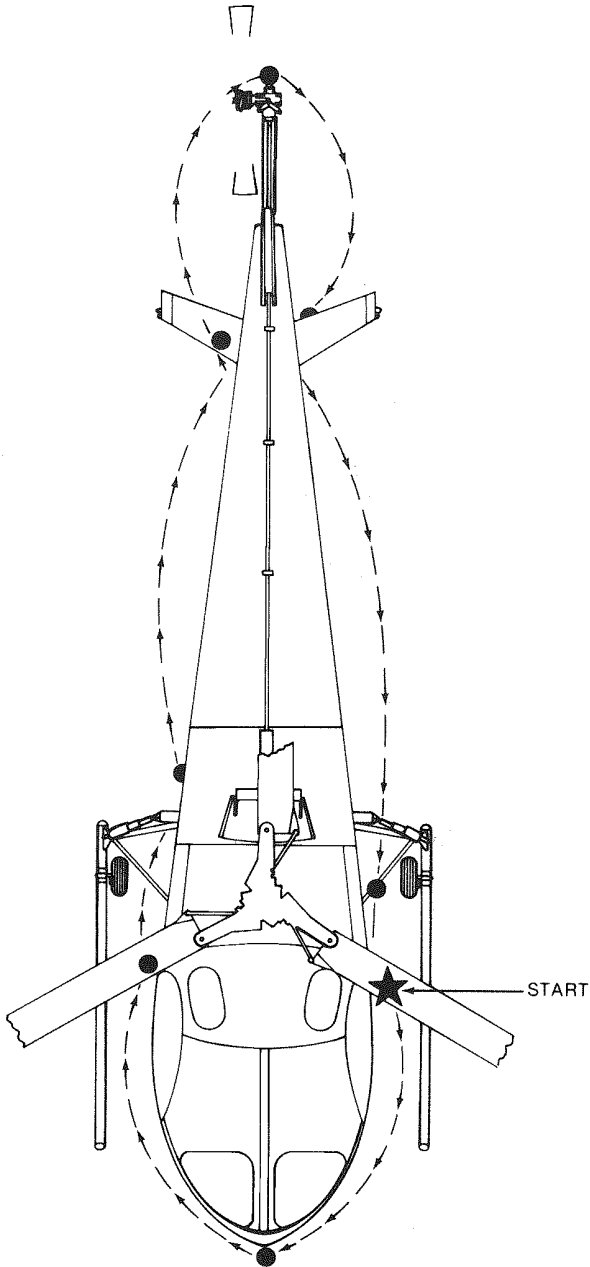

**EXTERIOR INSPECTION**

I

INTENTIONALLY LEFT BLANK

## SECTION 8 - WEIGHT AND BALANCE INFORMATION

All helicopters are designed for certain limit loads and balance conditions. Changes in equipment which affect the empty weight center of gravity must be recorded in the aircraft and engine log book. It is the responsibility of the helicopter pilot to ensure that the helicopter is loaded properly. The empty weight, empty weight C.G. and useful loads are noted on the weight-balance sheet included in this Manual for this particular helicopter.

**NOTE:** The C.G. range for the 280 Helicopter is 92.0" to 98.0" from datum line at a maximum gross weight of 2150 lbs. Listed on page FM 8-5 is a typical loading condition of the 280 Helicopter, both rearward C.G. and forward C.G. condition.

### WEIGHT AND BALANCE

The removal or addition of fuel or equipment results in changes to the center of gravity and weight of the aircraft, and the permissible useful load is affected accordingly. The effects of these changes must be investigated in all cases to eliminate possible adverse effects on the aircraft's flight characteristics. The horizontal reference weighing point is located 20 inches forward of the center bolt in rear skid attachment.

Maximum Gross Weight	2150 lbs.
Empty Weight (no accessories, fuel or oil)	1450 lbs.
Useful Load	700 lbs.
Approved Forward C.G. Limit	Station 92
Approved Aft C.G. Limit	Station 98

### TOOLS AND EQUIPMENT

Tape Measure	Commercial
Scale (two)	1000 lbs. capacity
Scale — tail (one)	100 lbs. capacity
Level — bubble-type	Commercial
Work stand	As required

### DETAILED PROCEDURE FOR WEIGHING 280 SERIES HELICOPTER

- Thoroughly clean helicopter.
- Helicopter will be weighed inside a closed building to prevent errors in scale readings due to wind. Helicopter will be placed in a level flight attitude.
- Check for proper installation of all accessory items. Check to determine if the scales that are being used

- have been calibrated recently, and check to see that the scales will zero out before weighing helicopter.
- d. The helicopter will be weighed without fuel, but the weight and balance record will reflect corrections to indicate the amount of unusable fuel 2 U.S. gallons. The helicopter may be weighed with full oil or without oil, but the weight and balance report should be corrected accordingly.
  - e. Tare will be noted when helicopter is removed from the scales.
- NOTE:** Check oil level of main transmission and tail rotor transmission. Check to see that the main rotor blades are in uniform position, 120° apart.
- f. Close and secure both doors, left and right hand sides.
  - g. Hoist or jack helicopter clear of ground.
  - h. Position two main scales beneath the skids.
  - i. Position a pipe nipple in the center of left and right hand scales at 20 inches forward of center bolt in rear skid attachment. (Detail No. 1)

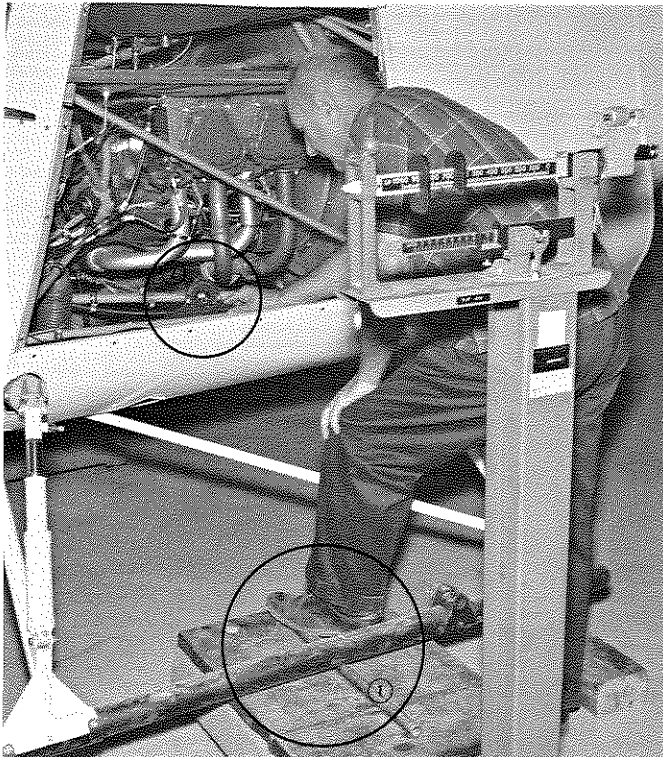

**ENSTROM 280**

- j. Height of tail to be adjusted for level.
- k. Level fore and aft to be taken at lower pylon tube, left side, so identified. (Detail No. 2)
- l. Lateral level taken at lower forward pylon tube.



- m. Small scale will be located under tail rotor at the center line of the tail rotor output shaft, shown above.
- n. Using jack, raise or lower tail as required to level the aircraft along the longitudinal axis, paying attention to the level on the longitudinal and lateral pylon tubes.
- o. Read and record weight from each of three scales.
- p. Calculate weight and center gravity on attached form, with weight data. Empty weight will be "dry weight."
- q. All items added or subtracted will be listed on the attached form with weight, arm, and moment.

**CAUTION:** Weight and measurement readings are critical. Double check results.

**ENSTROM 280**

r. Remove helicopter from scales.

**CAUTION:** Do not remove curbing, jack, nipples, blocks, etc., from scales. These items constitute tare weight.

- s. Read and record tare weight from each of the three scales. An official weight and balance report is prepared in connection with each helicopter presented for airworthiness certification at the Enstrom Corporation. All these reports are marked "actual weight."
- t. This weight and balance report, and equipment list will be prepared and supplied with each helicopter.
- u. Use Form No. F-165 Basic Weight and Balance Report to give you a continuous history of weight changes throughout the life of your helicopter.



## ENSTROM 280

### LOADING INFORMATION

NOTE: It is the responsibility of the helicopter pilot to insure that the helicopter is loaded properly. The empty weight, empty weight CG and useful load are noted on the weight and balance sheet included in this Manual for this helicopter.

CG Range: 92.0 to 94.0 Maximum Gross Weight: 2150 lbs

92.0 to 98.0 Maximum Gross Weight: 1930 lbs

### TYPICAL LOADING

#### Rearward CG

	<u>Weight</u>	<u>Arm</u>	<u>Moment</u>
Empty Weight (including undrainable engine oil, gearbox oil and unusable fuel)	1450.0	101.5	147175.0
Engine Oil	15.0	100.5	1507.50
Fuel, 40 gal	240.0	96.0	23040.0
Pilot	140.0	64.0	8960.0
	<u>1845.0</u>	<u>97.9</u>	<u>180682.5</u>

#### Forward CG

	<u>Weight</u>	<u>Arm</u>	<u>Moment</u>
Empty Weight (including undrainable engine oil, gearbox oil and unusable fuel)	1450.0	101.5	147175.0
Engine Oil	15.0	100.5	1507.5
Fuel, 30.0 gal	175.0	96.0	16800.0
Pilot & Passengers	510.0	64.0	32640.0
	<u>2150.0</u>	<u>92.15</u>	<u>198122.5</u>

#### Lateral Offset Moment

Pilot (left seat)	190	-13.5	-2565
Co-Pilot (right seat)	130	+13.5	+1755
			<u>- 810 in. lb.</u>

# APPROVED CENTER OF GRAVITY ENVELOPES LATERAL AND LONGITUDINAL

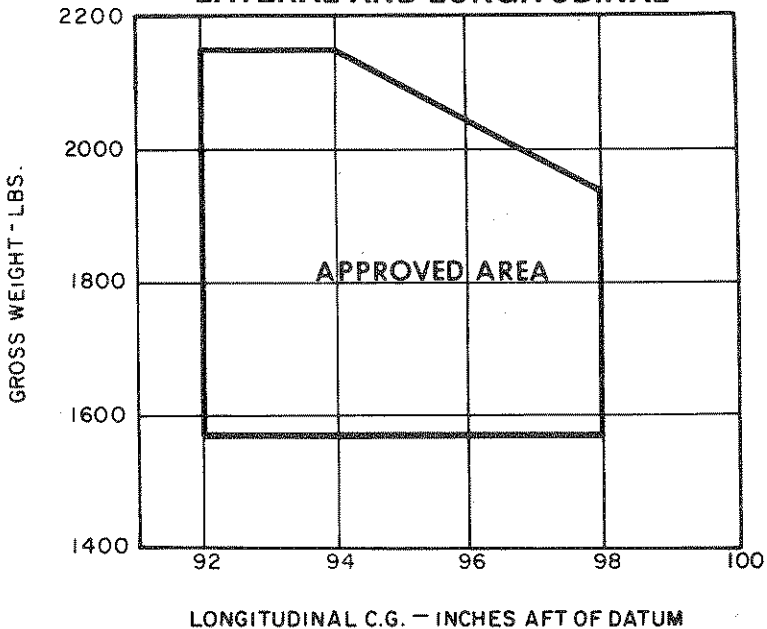

## LATERAL OFFSET MOMENT ENVELOPE

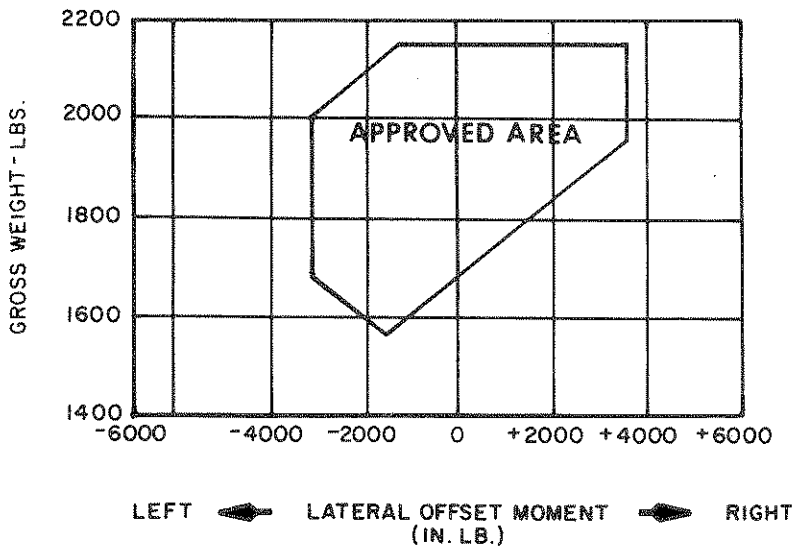

# WEIGHT AND BALANCE REPORT

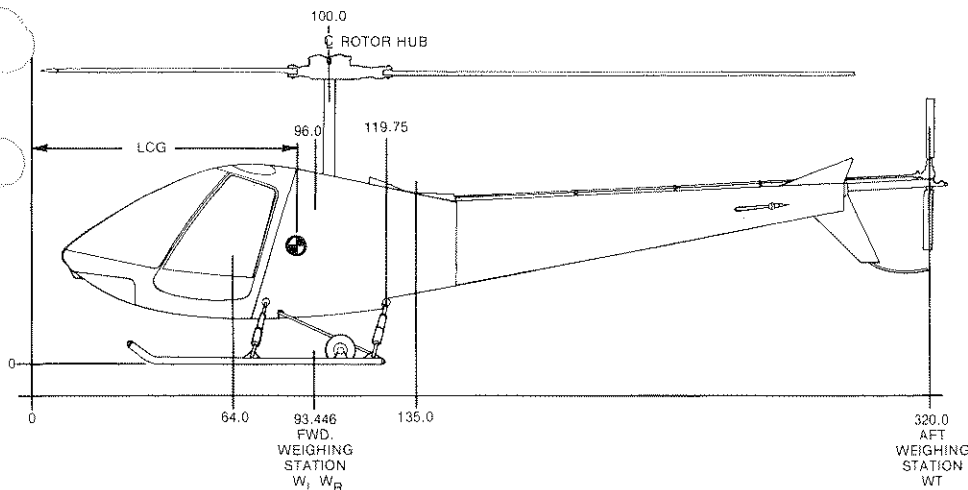

Model \_\_\_\_\_ Serial No. \_\_\_\_\_ Registration No. \_\_\_\_\_

**FWD. c/g limit 92.0"**

**AFT. c/g limit 98.0"**

Weigh point	Scale—lbs.	Tare	Net wt.	Arm	Moment x 1000
Left gear			(W <sub>L</sub> )		
Right gear			(W <sub>R</sub> )		
Tail			(W <sub>T</sub> )		
<b>Total</b>				X	

$$LCG = \frac{W_T (320.0) + (W_L + W_R) (93.446)}{W_T + W_L + W_R} = \underline{\hspace{2cm}}$$

Date \_\_\_\_\_ Weighed by \_\_\_\_\_

This electronic document is not linked to a subscription for revision control or distribution. Refer to the Technical Publications Status link under the Technical Support Page of the Enstrom Helicopter website for the current revision level of the 260 Rotorcraft Flight Manual.







# AIRCRAFT WEIGHT AND C. G. CALCULATION

	Weight lbs.	Arm in.	Moment 1000 in./lbs.
Weight (as weighed)			
Less: optional & surplus weight			
Plus: missing std. equipment			
Total – weight empty – std. aircraft	Computed		
	Actual		
Plus: engine oil			
Plus: optional equipment & kits			
Total basic weight			

This electronic document is not linked to a subscription for revision control or distribution. Refer to the Technical Publications Status link under the Technical Support Page of the Enstrom Helicopter website for the current revision level of the 260 Rotorcraft Flight Manual.



**UNCONTROLLED COPY WHEN DOWNLOADED OR PRINTED**





This electronic document is not linked to a subscription for revision control or distribution. Refer to the Technical Publications Status link under the Technical Support Page of the Enstrom Helicopter website for the current revision level of the 260 Rotorcraft Flight Manual.



**UNCONTROLLED COPY WHEN DOWNLOADED OR PRINTED**

## ENSTROM 280 EQUIPMENT LIST

Serial No. \_\_\_\_\_

FAA Approved Registration No. \_\_\_\_\_ Date \_\_\_\_\_

Check On	Date Off	No.	Item	Wt.	Arm
<b>INSTRUMENTS — REQUIRED</b>					
			Altimeter	1.2	36
			Airspeed	.5	36
			Tachometer	1.3	36
			Manifold — Fuel Pressure	1.5	36
			Instrument Cluster	2.0	36
			Oil Temperature		
			Oil Pressure		
			Gear Box Temperature		
			Cylinder Temperature		
			Fuel Quantity		
			Ammeter		
			Compass	1.0	40
			OAT Gauge	0.5	55
			Ball Bank Indicator		
<b>OPTIONAL EQUIPMENT</b>					
		1	Night lighting equipment (including combination strobe and position lights, internally lit instrument cluster, eyebrow type instrument lighting)		
		2	Map light	.5	80
		3	8 day clock	.5	36
		4	Hour meter	.75	88
		5	Soundproofing		
		6	Defroster — F28A, F28C		
		7	Strobe lights — F28A		
		8	Float build up		
		9	Center radio console (F28A, F28C)		
		10	Cargo Hook		
		11	Extra head set	2.0	80
		12	Cabin heater & defroster combination 280, 280C	3.5	46
		13	Snow shoe installation	18.0	100.9
		14	Cabin heater (F28A, F28C)	4.1	36.0
		15	Baggage compartment	10.0	135.0
		16	Flotation gear/with hardware		
		17	Dual controls	12.0	50
		18	Floor carpet, int. trim & headliner	6.0	65.0
		19	Fed. 12V. twin speaker—siren	11.3	79
		20	Litter kit—single	24.0	100.0
		21	King KT 76 transponder	4.0	34.0
		22	Shoulder harness w/reel — single	3	82
		23	Shoulder harness w/reel — double	6	82
		24	First aid kit	5.2	135
		25	Ashtrays & lighter	1.0	32.0
		26	Fire extinguisher	5.7	80.0
		27	External power unit (APU)	1.0	75.0
		28	Narco com 11 AH w/intercom	4.0	34.0
		29	Narco nav 11	3.5	32.0
		30	Narco ADF — 140	4.3	33.0
		31	Narco DME 190	6.6	34.0
		32	Narco AT50A transponder	4.0	34.0
		33	King KR86 ADF	3.9	34.0
		34	Gyro horizon model R.C. Allen — 25	3.4	32.0
		35	RCA-15A-2 directional gyro	2.3	32.0
		36	King KX175B NAV/COM	7.0	34.0
		37	ADF 140 loop & sense antenna	3.1	138.0
		38	Presidential doors (door pockets)	6.0	60.0
		39	Instantaneous vertical speed indicator	1.3	34.0
		40	Alm 200 directional gyro	3.8	34.0
		41	Antenna (vor)	1.3	194
		42	Narco DGO-10	4.7	32.0
		43	Dual landing light	3.2	25.0
		44	King KR 85 w/indicator	7.0	34.0
		45	Chadwick tank		
		46	Ground handling wheel(s)	13.0	104.7
		47	King KI-225-01 indicator	1.3	34.0
		48	Narco NAV 14	2.25	34.0
		49	Narco ELT	3.3	135

This electronic document is not linked to a subscription for revision control or distribution. Refer to the Technical Publications Status link under the Technical Support Page of the Enstrom Helicopter website for the current revision level of the 280 Rotorcraft Flight Manual.



## SECTION 9 - OPERATIONAL INSTRUCTIONS

### INTRODUCTION

The operating data and information contained herein is not intended to provide flight instructions, but to present a verbal picture of the helicopter handling qualities and control application through the various phases of the flight regime. Also discussed are flight characteristics which are common to most helicopters, and the special features pertinent to the Model 280 Helicopter.

**Solo Flight.** Solo flight is permitted from the left side only.

**Taxiing.** Taxiing, as literally interpreted, is not possible as the helicopter is equipped with skid-type landing gear. Movement of the helicopter from one ground position to another can be accomplished by ground personnel, when the rotors are not turning, with the use of quickly installed ground handling wheels or by the pilot flying the helicopter from one location to another at an altitude in close proximity to the ground surface.

**Takeoff — Types of Takeoff.** The known factors which must be considered prior to takeoff include gross weight, temperature, density altitude, and the area from which operations are to be conducted. With this knowledge and the ability of the Model 280 to operate from either prepared or unprepared areas and surfaces, the type of takeoff can be easily determined.

**Normal Takeoff To Hover.** A normal liftoff to a hovering altitude within ground effect is the most common type of takeoff and should be used whenever possible. Normal liftoff can be accomplished at moderate altitudes and at average operating gross weights. In this type of takeoff, the safety factor is high because the helicopter is lifted from the ground vertically to a height of 4 to 5 feet where the flight controls and engine may be checked for normal operation before starting a forward speed climb. A normal takeoff is made in the following manner:

- a. Increase throttle to 2900 RPM, with the collective pitch **FULL DOWN**.
- b. Place cyclic control in the **NEUTRAL** position or to a position which places rotor plane parallel to horizontal if helicopter is sitting on a slope.
- c. Increase collective pitch control slowly and smoothly until a hovering altitude of 3 to 5 feet is obtained, applying anti-torque pedal to maintain heading as collective pitch is increased.

d. As the helicopter breaks ground, minor corrections of the cyclic control may be required to insure vertical ascent, and directional heading maintained by the use of the appropriate anti-torque control pedal.

**Normal Takeoff From Hover.** Hover briefly to determine and insure that the engine and flight controls are operating properly. From a normal hover altitude of 3 to 5 feet, apply forward cyclic stick to accelerate smoothly into effective translational lift. Maintain hovering altitude with an application of collective pitch until translational lift has been obtained and the ascent has begun. Then slowly lower nose of helicopter to an altitude that will produce an increase of airspeed to best climb speed. Adjust controls and power as required to establish the desired rate of climb.

**Maximum Power Takeoff.** Hover helicopter 3 to 5 feet altitude — 2900 RPM. Apply forward cyclic smoothly. As forward motion increases, apply collective and throttle until full manifold pressure is attained (throttle full open 2900 RPM). Do not increase collective pitch beyond this point (overpitching) as this will cause engine and rotor RPM to decrease. Maintain 3 to 5 feet altitude by use of cyclic control. As translational lift speed is reached (15-20 MPH), apply aft cyclic to seek climb angle that will allow helicopter to climb and accelerate to 58 mph (best rate of climb speed). Maintain heading during takeoff by coordinated use of directional control pedals and cyclic.

**Maximum Power Takeoff From Confined Areas.** Conditions may occur in which the helicopter must be operated from confined areas in which takeoff distances (from hover to reach 58 mph) are not sufficient to clear obstacles that may be in the flight path (trees, buildings, wires, etc.). In order to clear such obstacles safely, the climb portion of the takeoff must utilize the best angle of climb airspeed (30 mph safe side of height velocity curve). This angle of climb will substantially shorten the distance required to clear obstacles. To accomplish this type of takeoff, hover helicopter at 3 to 5 feet altitude and 2900 RPM. Apply forward cyclic smoothly. As helicopter begins to accelerate forward, apply collective and throttle until full manifold pressure is obtained (throttle full open, 2900 RPM engine). Do not increase collective beyond this point (overpitching) as this will cause engine and rotor RPM to decrease. Maintain 3 to 5 feet altitude by use of cyclic control. As translational speed is reached (15-20 mph) apply aft cyclic

to seek climb angle that will maintain 30-35 mph (refer to height-velocity diagram in flight manual). After clearing all obstacles at this airspeed, apply forward cyclic and readjust collective and throttle as desired for further flight.

**NOTE:** If RPM is lost due to overpitching, it may be regained by maintaining full throttle, lowering collective slightly and applying some aft cyclic. It is imperative that the helicopter has accelerated a little beyond translational speed in order to accomplish this maneuver. Therefore, good judgment must be used to determine the rate at which the helicopter is accelerated from hover to translational speed and to determine if sufficient distance is available to clear obstacles under the existing density altitude conditions.

**Crosswind Takeoff.** In the event a crosswind takeoff is required, normal takeoff procedures are to be followed. However, as the helicopter leaves the ground, there will be definite tendency to drift downwind at a rate proportionate to the wind velocity. This tendency can be corrected by moving and holding the cyclic stick sufficiently in the direction of the wind to prevent downwind drift. During cross-wind takeoff, it is advisable to keep open areas to windward side of flight path to facilitate emergency landing if it should be necessary.

### **NORMAL APPROACH FOR LANDING**

The object of a normal approach is to fly the helicopter to a hover over the selected spot prior to touchdown. To accomplish this objective, the cruise airspeed is decreased gradually to 58 MPH and engine speed is maintained at 2900 RPM. Control rate of descent with collective and throttle (manifold pressure); airspeed with cyclic control. As the selected landing area is approached, the airspeed and rate of descent are decreased until a zero ground speed hovering attitude is attained at approximately 3 to 5 feet altitude.

### **STEEP APPROACH**

Steep approach procedure requires a precision power control approach, and is used to clear obstacles in the flight path when accomplishing a landing in a confined area. The airspeed in a steep approach should be 30 to 35 MPH (safe side of H/V curve) and the rate of descent should be as low as possible for the desired angle of descent. Since a relatively high amount of power will be required to control the rate of descent, a minimum amount

of additional power will be required to accomplish a hover. The aiming point to spot of intended hover in ground effect should be as near as possible after clearing final obstacles. This will allow an over-run to get helicopter stopped in case power settling should occur during slowdown from 30 MPH down to 0 airspeed. During descent, the airspeed is controlled by appropriate cyclic stick application and the rate of descent is controlled by proper application of collective pitch and throttle. In the final stages of approach, the collective pitch is increased gradually as the cyclic stick is adjusted to reduce the airspeed from 30 to 35 MPH to 0 groundspeed. This should be accomplished in a way which will reduce the rate of descent and groundspeed to zero the moment the hovering altitude is reached.

### **LANDING-LANDING SITE EVALUATION**

The versatility of the helicopter permits safe operation from unfamiliar and unprepared sites, such as open fields, mountain knolls and ridges, beaches, snow, and iced areas. Any selected landing site in the afore-mentioned areas must be properly evaluated and the pilot must use proper techniques to effect landings and take-offs from these sites. Although the helicopter is designed for and is capable of operation from restricted areas, the final analysis of the situation on the decision to land must be determined by the best professional judgement of the pilot. Prior to attempting operation of the helicopter from unprepared areas, the pilot must consider certain basic factors and evaluate one against the other to determine what undesirable factors will be present in the contemplated operations. The condition of the selected landing area can be evaluated by a low speed pass into the wind over the intended landing site. Generally, the landing site should be near level, and depending on existing density, altitude and gross weight conditions, should meet the obstacle clearance requirements set forth in this Manual. The pilot must also consider personal proficiency, wind and terrain roughness when evaluating the suitability of the landing area.

### **WIND DIRECTION AND VELOCITY**

The effects of wind on take-off and landings are important factors and should be considered in the operation of the helicopter; however, in planning critical helicopter operations, the effects of winds can be relied upon to assist in accomplishing landings and take-offs from unobstructed areas. If the helicopter were riding a gust of



wind on the final approach and the gust should decrease as the helicopter was approaching a hover, the helicopter would probably rapidly 'settle' if the wind factor was planned on to execute the landing. This condition will also hold true during the initial phase of take-off. If an operation is dependent on wind conditions, all other conditions being marginal, the helicopter gross weight should be reduced. When a landing area is determined to be marginal, the pilot, exercising good judgement, should select another site. Another effect of wind that must be considered is the 'lee' effect of the wind over hills, ridges, and obstacles. The downdrafts resulting from these conditions particularly affect the initial phase of take-off or final phase of landing.

### **NORMAL LANDING**

After completion of the normal approach to a hover altitude, maintain engine RPM and decrease collective pitch sufficiently to affect a constant, smooth rate of descent until touchdown. During final descent, make necessary corrections with directional pedals and cyclic control to maintain a level attitude and constant heading to minimize movement on ground contact. After ground contact, continue to decrease collective pitch smoothly and steadily until the entire weight of the helicopter is ground supported and then decrease collective pitch to minimum.

### **CROSSWIND LANDING**

Crosswind landings generally can be avoided in helicopter operations. Occasionally, when operating from unprepared areas, such as plowed or furrowed fields, ridges and upslope or down slope surfaces, necessity may require that crosswind landings be performed. When conditions demand and terrain features dictate, a crosswind landing is also utilized to preclude the necessity of landing on a high, tilting angle or a dangerous tail low attitude. Prior to accomplishing the crosswind landing, the pilot should evaluate the climatic conditions, including wind velocity and the terrain, and then proceed as follows: Engine RPM maximum, approach landing spot from crosswind direction if possible, and hover. Hold cyclic control into direction of wind to prevent side drift, and reduce collective pitch and descend as in normal landing.

### **FLIGHT CHARACTERISTICS - HANDLING AND STABILITY**

The flight characteristics of this helicopter in general are

similar to other single rotor helicopters. The particularly noticeable difference is the handling ease and additional stability that is evident during take-off, hovering, and all modes of flight. To obtain or increase helicopter forward speed, simultaneously apply forward control stick and increase main rotor pitch, and maintain power through constant flight condition. Altitude is maintained throughout the entire range of forward and rearward flight speeds by fore and aft movement of the cyclic control stick in coordination with collective pitch application. Directional heading is controlled by the application of lateral cyclic control and appropriate directional control pedal. Blade stall can only occur during flight and is caused by high angle attack on the retreating blade and occurs at the inboard section of the blade area. This condition can not be encountered when the helicopter is operated within the specified operating limits as stated in the Flight Manual. Blade stall is the result of numerous contributing factors such as gross weight, low rotor RPM, airspeed acceleration and altitude. The condition is most likely to occur at higher airspeeds and low operating RPM; it also follows that the condition will occur sooner with high values of altitude, gross weight, and angle of bank. The major warnings of approaching retreating blade stall conditions in the order in which they will generally be experienced are:

1. Abnormal 3 per revolution vibration.
2. Pitchup of the nose.
3. Tendency for the helicopter to roll in the direction of the stalled (left) side.

At the onset of blade stall vibration, the pilot should take the following corrective measures:

1. Reduce collective pitch.
2. Increase rotor RPM.
3. Reduce forward airspeed.
4. Descend to lower altitude.
5. Minimize maneuvering.

## **MANEUVERING FLIGHT**

Movement and response of the flight controls while conducting flight maneuvers is normal at all times when the helicopter is operating within the limitations set forth in the Flight Manual. Throughout the entire realm of flight, it will definitely be noted that minimum effort is required by the pilot for control of movement, and by use of trim system, a near zero control force effect effort is required,

regardless of the gross weight or CG location.

## **HOVERING FLIGHT**

The hovering capabilities of the Model 280 Helicopter for both in and out of ground effect hovering will allow flight operations to be excellent.

It should be remembered, however, that the performance of all helicopters is affected by numerous factors such as climatic conditions, altitude, temperature, and gross weight. It is a known fact that 'in ground effect' hovering performance is better than 'out of ground effect' performance for reason of the helicopter being in part supported by a cushion of air being provided by the rotor downwash when the helicopter is in close proximity to the ground. Additional performance will also be realized when operating at low temperatures, which is the equivalent of atmospheric density, and wind, which represents airspeed. Either of these conditions or a combination of both increases performance since low temperatures allow the engine and rotor to provide more lift and wind reduces the power required.

## **STUDENT TRAINING**

Autorotation practice should be carried out over terrain suitable for full autorotational landing in case of inadvertent engine stoppage. Sudden power cuts to idle position are not recommended since the fuel injector is quite sensitive to improper adjustment of idle mixture, idle rpm and sudden momentary leaning of mixture caused by sudden power reduction.

## **NOISE ABATEMENT**

Increased emphasis on improving the quality of our environment requires renewed effort on the part of all pilots to minimize the effect of aircraft noise on the public.

We, as helicopter pilots, can demonstrate our concern for environmental improvement by application of the following suggested procedures, and thereby tend to build public support for aviation:

1. Pilots operating helicopters over outdoor assemblies of persons, recreational and park areas, and other noise-sensitive areas should make every effort to fly not less than 2,000 feet above the surface, weather permitting, even though flight at a lower level may be consistent with the provisions of government regulations.

2. During departure from or approach to an airport or heliport, climb after takeoff and descent for landing should be made so as to avoid prolonged flight at low altitude near noise-sensitive areas.

**NOTE:** The above recommended procedures do not apply where they would conflict with ATC clearances or instructions, or where, in the judgment, an altitude of less than 2,000 feet is necessary for him to adequately exercise his duty to see and avoid other aircraft.

### **LEANING WITH AN ENSTROM ECONOMY MIXTURE INDICATOR [EGT] [WHEN INSTALLED]**

Exhaust gas temperature (EGT) as shown on the Enstrom economy mixture indicator may be used as an aid for mixture leaning in cruising flight at 75% power or less, i.e., 23" M.P. 2900 RPM.

To obtain a best power mixture, lean to peak EGT and then enrich the mixture until the EGT is on the rich side of peak by an increment of 100° F.

When leaning the mixture, if a distinct peak is not obtained, use the corresponding maximum EGT as a reference point for enriching the mixture to the desired cruise setting.

**Note:** Operation at peak EGT is not authorized except temporarily to establish peak EGT for reference. Operation on the lean side of peak EGT or within 50° rich of peak EGT is not approved. Any change in altitude or power will require a recheck of the EGT indication.

### **COLD WEATHER OPERATION**

The use of an external preheater and an external power source (APU) is recommended whenever possible to reduce wear and abuse to the engine and the electrical system. Preheat will thaw the oil trapped in the oil cooler which probably will be congealed prior to starting in extremely cold temperatures. When using an external power source, the position of the master switch is the **ON** position while the alternator switch is left in the **OFF** position until the APU plug is disconnected from the helicopter.

In very cold weather, the engine should be warmed up without the rotor system engaged for a period of 2 to 5 minutes at 1000 RPM.

Remove all accumulation of snow and ice prior to flight.

## ENSTROM 280

Failure to remove ice and snow accumulations can result in serious aerodynamic and structural effects when and if flight is attempted.

### BLADE TAPE

Polyurethane leading edge tape can be installed on the main rotor blades. If the tape is installed, it should be inspected before each flight for holes, blisters, bubbles, separation, and security of attachment. If any defects are noted, the tape must be removed or replaced before the next flight. If the helicopter is operated in rain, the tape life may be shortened considerably. Separation of part or all of the blade tape can cause an extremely rough rotor system. In this event the helicopter should be landed as soon as practical and the rotor system, blades, and blade tape inspected prior to further flight.

### LOSS OF TAIL ROTOR EFFECTIVENESS

Loss of tail rotor effectiveness (LTE) is a phenomenon which can occur in any single main rotor/anti-torque tail rotor helicopter. Although the 280 has a very effective tail rotor and does not exhibit any tendencies for LTE, the pilot should be aware that the potential for LTE, however small, does exist. As such, pilots should be aware of the causes and recovery techniques.

There are a number of factors which reduce the effectiveness of the tail rotor or increase the thrust required from the tail rotor. These factors include high power settings, low airspeeds, left crosswinds or tailwinds, and right, yawing turns. Under exactly the right conditions, these factors can combine to make the tail rotor virtually ineffective. This LTE can be recognized by an uncommanded right yaw which can not be stopped using the tail rotor pedals alone. Recovery from LTE can be accomplished by increasing forward speed, lowering the collective if altitude permits, and applying left pedal. The longer corrective actions are delayed, the more difficult it will be to recover from LTE.

This electronic document is not linked to a subscription for revision control or distribution. Refer to the Technical Publications Status link under the Technical Support Page of the Enstrom Helicopter website for the current revision level of the 280 Rotorcraft Flight Manual.

## SECTION 10 - DAY-TO-DAY CARE

If you wish to obtain maximum performance and dependability from your 280 Helicopter, certain inspection and maintenance requirements must be followed. It is always wise to follow a planned schedule of lubrication and maintenance based on the climatic and flying conditions encountered in your locality. Keep in touch with your Enstrom dealer and take advantage of his knowledge and experience. Your dealer is ready and willing to assist you and to keep you abreast of all changes, whether it be maintenance or periodic servicing of the helicopter.

### GROUND HANDLING

To lower the ground handling wheels, insert the slotted handle facing forward. While applying a constant pressure to handle, release pin. Pull up and aft with a lifting motion until the holes line up. Insert the locking pin. Keep a firm grip on the handle until pin is in place.

- CAUTION:**
1. Keep your feet from under the skids.
  2. Stay on outside of skid, do not straddle.

### MOORING

Although it is not generally necessary to tie down the helicopter, a nylon rope can be attached to the landing gear cross tube at the oleo attach points. One blade should be placed parallel to tail cone and tied to tail cone.

### TRANSPORTING

If transporting helicopter on trailer or truck, skids may be secured to bed of trailer allowing oleo's to function.

- a. Remove three main rotor blades and store in blade box.
- b. Secure tail rotor.
- c. Disconnect battery.

### STORAGE

The metal-fiberglass construction of your 280 makes outside storage practical, although inside storage will increase its life just as inside storage increases the life of your car. If your 280 must remain inactive for a time, cleanliness is probably the most important consideration. It is suggested that a canvas or nylon cover be placed over the rotor head. If storage is for an extended period, see your Lycoming Manual for preservation information.

### HOISTING

To lift the entire helicopter, the use of a nylon sling of

approximately 3,000 lbs. capacity is required. The nylon sling is placed around each grip assembly.

### **JACKING**

It is possible to jack up the helicopter inboard of upper oleo attach points on forward and aft cross tubes.

**CAUTION:** Support the tail cone at extreme end.

### **EXTERIOR PAINT**

The finish of your helicopter should be kept clean. It requires no special care. When washed, however, water should not be sprayed directly into any bearings. Any good grade of car wax will help to maintain the condition of the factory finish. It is very important that the main rotor blades be kept clean and free of dirt. After all, the blades are an airfoil, and to get maximum lift, they must be clean.

### **WINDOWS AND DOORS**

The windows and doors are made from a fine grade of acrylic plastic. These surfaces can be scratched if dirt, bugs or other foreign material are not removed promptly. If the windshield is excessively dirty, a water and mild soap solution will help lift the dirt.

**CAUTION:** Never take a rag to wipe dirt from the glass areas on your helicopter. There are many good products made especially for the cleaning of acrylic plastic surfaces.

### **UPHOLSTERY AND CARPETS**

No special care is required to keep the interior of your helicopter clean. A good stiff broom will help remove the imbedded dirt; vacuum the interior whenever possible. Any good upholstery cleaner can be used on the carpets and seats, but a word of caution when cleaning the seat belts. They are nylon, and certain cleaning agents will destroy the material used in their construction.

### **LANDING GEAR SHOCK STRUTS**

The oleo struts are of the air-oil type and require little maintenance. It is suggested that the oleo be wiped off frequently to keep the abrasive action of dirt and oil to a minimum.

### **AIR CLEANER OR FILTER**

The air cleaner is an important part of your engine's induction system. If it becomes dirty or clogged, your engine will use more fuel and will not produce maximum



## ENSTROM 280

power. Excessively dirty filters will allow particles of dirt to be sucked into the cylinders, causing major damage. If your helicopter is operated in any dusty and high grass areas, check the air filter more frequently.

### LIGHTS

Check the electrical system of the helicopter daily and always before night flying is planned. Keep the light lens clean for maximum brilliance.

### BATTERY

The battery will normally require only routine maintenance. However, if you should operate in a warm climate, an occasional check for fluid level is recommended. Keep the battery terminals and battery compartment free of corrosion.

### DAMPERS-MAIN ROTOR

To check for lead-lag operation, raise the blade off its droop stop and move each blade fore and aft by gripping blade at tip. A resistance indicates damper operation. There should be no undamped motion.

### TRANSMISSION-MAIN

The transmission requires no special attention other than checking the sight gauge on the rear of the transmission on the right-hand side.

### TRANSMISSION-TAIL ROTOR

The transmission requires no special attention other than checking the oil level by sight gauge.

### LUBRICATION

Lubrication information is included in the Maintenance Manual. It is imperative that the correct lubricants be used and trained personnel do this job properly. Each item should be serviced at prescribed intervals. At the same time, all other items requiring more frequent service should receive attention. The intervals stated on the lubrication diagram should be considered maximum for average service. If your helicopter is operated under abnormal conditions, check these items more frequently.

### EXCESSIVE GREASE

After a helicopter is returned from a routine inspection, the rotor head, tail rotor, and the tail rotor drive shaft will throw out grease. To keep the helicopter finish bright, remove this grease as soon as possible to prevent its

## ENSTROM 280

sticky surface from collecting dirt.

### MAIN ROTOR AND TAIL ROTOR BLADES

Preflight inspection of the main and tail rotor blades for nicks and an occasional wiping with a clean cloth to remove bugs and stains, coupled with regular lubrication of the hubs, will assure long, troublefree service. Never use an alkaline cleaner on the rotors; remove grease and dirt with carbon tetrachloride, Stoddard solvent, or any other mild solvent that will not attack the adhesive bonding of the blade.

In coastal areas where the air is salt-laden or if pitting of the blade leading edge is noted, use polyurethane tape on the leading edge for protection. This tape may be obtained from the Enstrom Customer Service Department. If the helicopter is equipped with this tape, the tape must be inspected before each flight. Look for holes, bubbles, blisters, or separation of the tape. If any defects are found, the tape must be removed or replaced before further flight. The tape should be kept clean in the same manner as the rest of the blade, except that it should be cleaned only with soap and water. Do not use solvent on or around the blade tape.

### FUEL

As you will note, the fuel tanks on your helicopter are placarded for quantity and octane of fuel to be used. The engine requires 100/130 minimum grade aviation fuel. The use of other types of fuel such as automobile or lower octane aviation fuel will cause severe engine damage and will void the engine warranty. Be certain that fuel contamination due to worn out and inoperative filtration system, dirty fuel hose nozzles, rain or any other foreign material does not enter your helicopter's fuel system.

### OIL

The engine manufacturer has recommended the (see FM 2-1 and Engine Operator's Manual) types of oil to be used in the different temperature ranges. These recommendations should be followed to aid in cold weather starting and proper hot weather lubrication of your helicopter engine. Care should be taken when adding oil that oil spouts are free of dirt and foreign material, oil can tops are clean before installing oil spout, and when removing oil filler cap, dirt does not enter the oil sump. When installing the engine oil filler cap, check it for security and cleanliness.

### COOLING SYSTEM

If unusually high oil temperature is encountered, remove oil cooler shroud and check for foreign matter.

### REQUIRED F.A.A. FORMS

Miscellaneous data, information, and licenses are a part of

Revised: **FEB 17 1989**

Report No. 28-AC-013

UNCONTROLLED COPY WHEN DOWNLOADED OR PRINTED

the aircraft file. The following is a check list for that file. In addition, a periodic check should be made of the latest Federal Aviation Agency Regulations to assure that all data requirements are met.

- A. To be carried in the helicopter at all times.
  - 1. Aircraft Airworthiness Certificate Form ACA 1362
  - 2. Aircraft Registration Certificate Form ACA 500A
  - 3. Aircraft Radio Station License
  - 4. Weight and Balance Report
  - 5. Aircraft Equipment List
  - 6. Flight Manual
- B. Since the regulations of other nations may require other documents and data, owners of exported aircraft should check with their own aviation officials to determine their individual requirements.
- C. Inspection Periods: FAA Regulations require that all aircraft have a periodic (annual) inspection as provided by the administration, and performed by a person designated by the administration. In addition, 100-hour inspections by an "appropriately rated mechanic" are required if the aircraft is flown for hire. The manufacturer recommends the 100-hour inspection for your helicopter. A copy of the sample inspection forms, including the 50, 100, periodic and lubrication guides are included in the Maintenance Manual.

This electronic document is not linked to a subscription for revision control or distribution. Refer to the Technical Publications Status link under the Technical Support Page of the Enstrom Helicopter website for the current revision level of the 280 Rotorcraft Flight Manual.

